

(12) **United States Patent**
Peshkin et al.

(10) **Patent No.:** US 10,108,288 B2
(45) **Date of Patent:** *Oct. 23, 2018

(54) **TOUCH INTERFACE DEVICE AND METHOD FOR APPLYING CONTROLLABLE SHEAR FORCES TO A HUMAN APPENDAGE**

(71) Applicant: **Northwestern University**, Evanston, IL (US)

(72) Inventors: **Michael A. Peshkin**, Evanston, IL (US); **J. Edward Colgate**, Evanston, IL (US)

(73) Assignee: **Northwestern University**, Evanston, IL (US)

(*) Notice: Subject to any disclaimer, the term of this patent is extended or adjusted under 35 U.S.C. 154(b) by 0 days.

This patent is subject to a terminal disclaimer.

(21) Appl. No.: **15/789,495**

(22) Filed: **Oct. 20, 2017**

(65) **Prior Publication Data**

US 2018/0059849 A1 Mar. 1, 2018

Related U.S. Application Data

(63) Continuation-in-part of application No. 14/734,868, filed on Jun. 9, 2015, now Pat. No. 9,811,194, which (Continued)

(51) **Int. Cl.**
G06F 3/041 (2006.01)
G06F 3/01 (2006.01)
(Continued)

(52) **U.S. Cl.**
CPC **G06F 3/0414** (2013.01); **G06F 3/016** (2013.01); **G06F 3/041** (2013.01); **G06F 3/044** (2013.01);
(Continued)

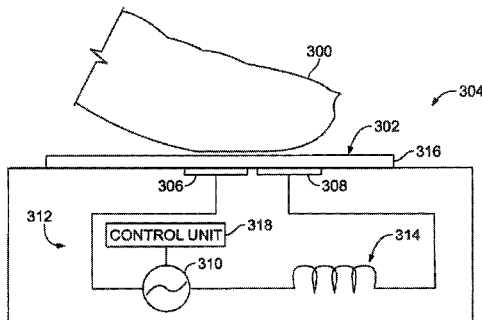

(58) **Field of Classification Search**
CPC G06F 3/046; G06F 3/0414; G06F 2203/04112; G06F 3/0412;
(Continued)

(56) **References Cited**

U.S. PATENT DOCUMENTS

5,587,937 A 12/1996 Massie et al.
5,631,861 A 5/1997 Kramer
(Continued)

FOREIGN PATENT DOCUMENTS

JP 2008-287402 11/2008
WO WO2010105001 9/2010
(Continued)

OTHER PUBLICATIONS

Goethals, Tactile Feedback for Robot Assisted Minimally Invasive Surgery: An Overview, paper [online], Jul. 2008.
(Continued)

Primary Examiner — Abhishek Sarma

(74) *Attorney, Agent, or Firm* — Vedder Price P.C.

(57) **ABSTRACT**

A method of moving a plurality of appendages of an operator in contact with a touch surface including the steps of measuring a plurality of locations when the touch surface is touched by the plurality of appendages, moving the touch surface in a swirling motion by one or more actuators coupled with the touch surface, controlling a voltage on each of a plurality of electrodes disposed below the touch surface, controlling an electrostatic normal force acting on each of the appendages by adjusting the voltage applied to each of the plurality of appendages by each electrode lying beneath the appendage, synchronizing the electrostatic normal force generated by the voltage applied to each of the plurality of appendages with the swirling motion by basing a frequency of the swirling motion on the frequency of application of the electrostatic normal force.

15 Claims, 9 Drawing Sheets

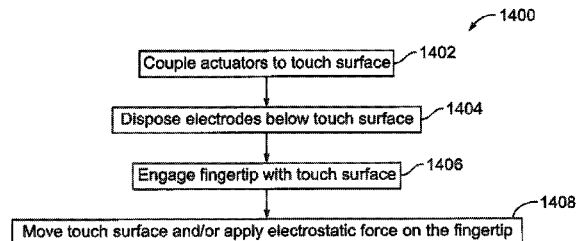

Related U.S. Application Data

is a continuation of application No. 13/468,695, filed on May 10, 2012, now Pat. No. 9,122,325.

(60) Provisional application No. 61/484,544, filed on May 10, 2011, provisional application No. 61/484,564, filed on May 10, 2011.

(51) **Int. Cl.**

G06F 3/045 (2006.01)
G06F 3/046 (2006.01)
G06F 3/044 (2006.01)

(52) **U.S. Cl.**

CPC **G06F 3/045** (2013.01); **G06F 3/046** (2013.01); **G06F 3/0412** (2013.01); **G06F 3/0416** (2013.01); **G06F 2203/04101** (2013.01); **G06F 2203/04105** (2013.01); **G06F 2203/04112** (2013.01); **G06F 2203/04113** (2013.01)

(58) **Field of Classification Search**

CPC G06F 2203/04105; G06F 3/044; G06F 3/041; G06F 3/045; G06F 2203/04101; G06F 2203/04113; G06F 3/0416; G06F 3/016

See application file for complete search history.

(56) **References Cited**

U.S. PATENT DOCUMENTS

5,709,219 A 1/1998 Chen et al.
 6,059,506 A 5/2000 Kramer
 6,337,678 B1 1/2002 Fish
 6,351,054 B1 2/2002 Cabuz et al.
 6,429,846 B2 8/2002 Rosenberg et al.
 6,693,516 B1 2/2004 Hayward
 6,970,160 B2 11/2005 Mulligan et al.
 6,979,164 B2 12/2005 Kramer
 7,148,875 B2 12/2006 Rosenberg et al.
 7,271,707 B2 9/2007 Gonzales
 7,390,157 B2 6/2008 Kramer
 7,714,701 B2 5/2010 Altan et al.
 7,742,036 B2 6/2010 Grant et al.
 7,825,903 B2 11/2010 Anastas et al.
 8,253,306 B2 8/2012 Morishima et al.
 2001/0026266 A1 10/2001 Schena et al.
 2001/0043847 A1 11/2001 Kramer
 2003/0038776 A1 2/2003 Rosenberg et al.
 2003/0151597 A1 8/2003 Roberts et al.
 2003/0179190 A1 9/2003 Franzen
 2004/0237669 A1 12/2004 Hayward et al.
 2005/0017947 A1 1/2005 Shahoian et al.
 2005/0030284 A1 2/2005 Braun et al.
 2005/0030292 A1 2/2005 Diederiks
 2005/0057527 A1 3/2005 Takenaka et al.
 2005/0173231 A1 8/2005 Gonzales
 2006/0115348 A1 6/2006 Kramer
 2006/0209037 A1 9/2006 Wang et al.
 2006/0279548 A1 12/2006 Geaghan
 2007/0146317 A1 6/2007 Schena
 2007/0236450 A1 10/2007 Colgate et al.
 2007/0236474 A1 10/2007 Ramstein
 2008/0048974 A1 2/2008 Braun et al.
 2008/0060856 A1 3/2008 Shahoian et al.
 2008/0062143 A1 3/2008 Shahoian et al.
 2008/0062144 A1 3/2008 Shahoian et al.
 2008/0062145 A1 3/2008 Shahoian et al.
 2008/0068351 A1 3/2008 Rosenberg et al.
 2008/0111447 A1 5/2008 Matsuki
 2008/0129705 A1 6/2008 Kim et al.
 2008/0218488 A1 9/2008 Yang et al.
 2008/0303782 A1 12/2008 Grant et al.
 2009/0002328 A1 1/2009 Ullrich et al.

2009/0036212 A1 2/2009 Provancher
 2009/0079550 A1 3/2009 Makinen et al.
 2009/0267920 A1 10/2009 Faubert et al.
 2010/0079379 A1 4/2010 Demuynck et al.
 2010/0085169 A1 4/2010 Poupyrev et al.
 2010/0108408 A1 5/2010 Colgate et al.
 2010/0109486 A1 5/2010 Polyakov et al.
 2010/0141407 A1 6/2010 Heubel et al.
 2010/0149111 A1 6/2010 Olien
 2010/0156818 A1 6/2010 Burrough et al.
 2010/0231367 A1 9/2010 Cruz-Hernandez et al.
 2010/0231508 A1 9/2010 Cruz-Hernandez et al.
 2010/0231539 A1 9/2010 Cruz-Hernandez et al.
 2010/0231540 A1 9/2010 Cruz-Hernandez et al.
 2010/0231541 A1 9/2010 Cruz-Hernandez et al.
 2010/0231550 A1 9/2010 Cruz-Hernandez et al.
 2010/0309142 A1 12/2010 Cruz-Hernandez et al.
 2011/0012717 A1 1/2011 Pance et al.
 2011/0043477 A1 2/2011 Park et al.
 2011/0079449 A1 4/2011 Radivojevic
 2011/0128239 A1 6/2011 Polyakov et al.
 2011/0215914 A1 9/2011 Edwards
 2011/0267294 A1 11/2011 Kildal
 2011/0285667 A1 11/2011 Poupyrev et al.
 2012/0038559 A1 2/2012 Radivojevic et al.
 2012/0038568 A1 2/2012 Collems et al.
 2012/0062516 A1 3/2012 Chen et al.
 2012/0126959 A1 5/2012 Zarrabi et al.
 2012/0206248 A1 8/2012 Biggs
 2012/0206371 A1 8/2012 Turunen et al.
 2012/0232780 A1 9/2012 Delson et al.
 2012/0268386 A1 10/2012 Karamath et al.
 2012/0268412 A1 10/2012 Cruz-Hernandez et al.
 2013/0044049 A1 2/2013 Biggs et al.

FOREIGN PATENT DOCUMENTS

WO WO2010105006 9/2010
 WO WO2010139171 9/2010

OTHER PUBLICATIONS

Chubb et al.; "ShiverPad: A Device Capable of Controlling Shear Force on a Bare Finger"; Third Joint Eurohaptics Conference and Symposium on Haptic Interfaces for Virtual Environment and Teleoperator Systems; Mar. 18-20, 2009; pp. 18-23.
 Chubb et al.; "ShiverPad: A Glass Haptic Surface that Produces Shear Force on a Bare Finger"; Transactions on Haptics; 2010; pp. 1-10; vol. X, No. X.
 Minsky; "Computational Haptics: The Sandpaper System for Synthesizing Texture for a Force-Feedback Display"; PhD Thesis; Massachusetts Institute of Technology, Cambridge, MA; Jul. 6, 1995; pp. 1-217.
<http://iniremf.ifac.cnr.it/tissprop/htmlclie/htmlclie.htm>; Sep. 20, 2012; pp. 1-3.
www.senseg.com; Sep. 20, 2012; pp. 1-2.
<http://www.teslaatouch.com/>; Sep. 20, 2012; pp. 1-4.
 Reznik, D; Canny, J, (1998). A flat rigid plate is a universal planar manipulator. In IEEE International Conference on Robotics and Automation.
 O. Bau, I. Poupyrev, A. Jsrar, and C. Harrison, "TeslaTouch: Electro-vibration for Touch Surfaces," User Interface Science and Technology (UIST), Oct. 3-6, 2010. New York.
 S. Grimnes, "Electro-vibration, cutaneous sensation of microampere current," Acta. Physiol. Scand., vol. 118, No. 1, pp. 19-25, Jan. 1983.
 K. Kaczmarek, "Electrotactile display of computer graphics for bline—final report," National Eye Institute grant 5-ROI-EY10019-08, Dec. 23, 2004.
 K. Kaczmarek, K. Nammi, A.K. Agarwal, M.E. Tyler, S.J. Haase, and D.J. Beebe. "Polarity effect in electro-vibration for tactile display." IEEE Trans on Biomedical Engineering, 53(10):2047-2054, 2006.
 R. M. Strong and D. E. Troxel, "An electrotactile display," IEEE Trans. Man-Mach Syst., vol. MMS-1 I, No. 1, p. 72-79, 1970.

(56)

References Cited

OTHER PUBLICATIONS

S. M. Biggs, S. Haptic Interfaces, chapter 5, pp. 93-115. Published by Lawrence Erlbaum Associates, 2002.

G. Robles-De-La-Torre. Comparing the Role of Lateral Force During Active and Passive Touch: Lateral Force and its Correlates are Inherently Ambiguous Cues for Shape Perception under Passive Touch Conditions. pp. 159-164, 2002.

G. Robles-De-La-Torre and V. Hayward. Force can overcome object geometry in the perception of shape through active touch. *Nature*, 412:445-448, Jul. 2001.

J. Cerundolo, "Effect of Charge Migration in Electrostatic Tactile Displays," MS Thesis, Dept of Mechanical Engineering, Northwestern University, 2010.

Kaczmarek, K., J. Webster, P. Pach-y-Rita, and W. Tompkins. Electrotactile and vibrotactile displays/or sensory substitution systems. *IEEE Transactions on Biomedical Engineering*, 1991. 38(1): pp. 1-16.

Tang, H. and D. Beebe, A microfabricated electrostatic haptic display for persons with visual impairments. *IEEE Transactions on Rehabilitation Engineering*, 1998. 6(3): pp. 241-248.

Mallinckrodt, E., A. Hughes, and W. Sleator, Perception by the Skin of Electrically Induced Vibrations. *Science*, 1953. 118(3062): pp. 277-278.

A. Yamamoto, T. Ishii, and T. Higuchi, "Electrostatic tactile display for presenting surface roughness sensation," in *Industrial Technology, 2003 IEEE International Conj. on*, Dec. 2003, pp. 680-684.

M. Takasaki, H. Kotani, T. Mizuno, and T. Nara, "Transparent surface acoustic wave tactile display," in *International Conj. on Intelligent Robots and Systems*, Aug. 2005, pp. 3354-3359.

T. Watanabe and S. Fukui, "A method for controlling tactile sensation of surface roughness using ultrasonic vibration," in *Proc. of IEEE International Conf. on Robotics and Automation*, vol. 1, May 1995, pp. 1134-1139 vol. 1.

M. Biet, F. Giraud, and B. Lemaire-Semail, "Implementation of tactile feedback by modifying the perceived friction," *The European Physical Journal Applied Physics*, vol. 43, No. 1, pp. 123-135, Jul. 2008.

L. Winfield, J. Glassmire, J. E. Colgate, and M. Peshkin, "T-pad: Tactile pattern display through variable friction reduction," in *World Haptics Conj.*, 2007, pp. 421-426.

D. Wang, K. Tuer, M. Rossi, and I. Shu, "Haptic overlay device for flat panel touch displays," in *Symposium on Haptic Interfaces for Virtual Environment and Teleoperator Systems*, 2004.

E. C. Chubb, J. E. Colgate, and M.A. Peshkin, "Shiverpad: A device capable of controlling shear force on a bare finger," in *Proc. of the World Haptics Con/*, 2009, pp. 18-23.

E. C. Chubb, "Shiverpad: A haptic surface capable of applying shear forces to bare finger," Master's thesis, Northwestern University, Evanston, IL, USA, 2009.

Y. Kato, T. Sekitani, M. Takamiya, M. Doi, K. Asaka, T. Sakurai, and T. Someya, "Sheet-type braille displays by integrating organic field-effect transistors and polymeric actuators," *IEEE Transactions on Electron Devices*, vol. 54, No. 2, pp. 202-209, Feb. 2007.

Pasquero and V. Hayward, "Stress: A practical tactile display with one millimeter spatial resolution and 700 hz refresh rate," in *Proc. of Eurohaptics*, Jul. 2003.

V. Vincent Levesque and V. Hayward, "Experimental evidence of lateral skin strain during tactile exploration," in *Proc. of Eurohaptics*, Jul. 2003.

C. Harrison and S. E. Hudson, "Providing dynamically changeable physical buttons on a visual display," in *Proc. of the 27th international conj. on Human factors in computing systems*, 2009, pp. 299-308.

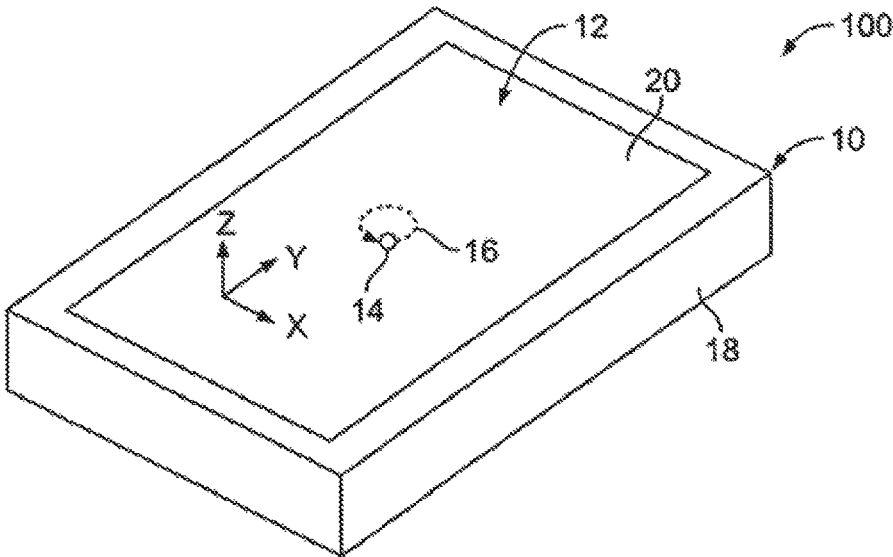

FIG. 1

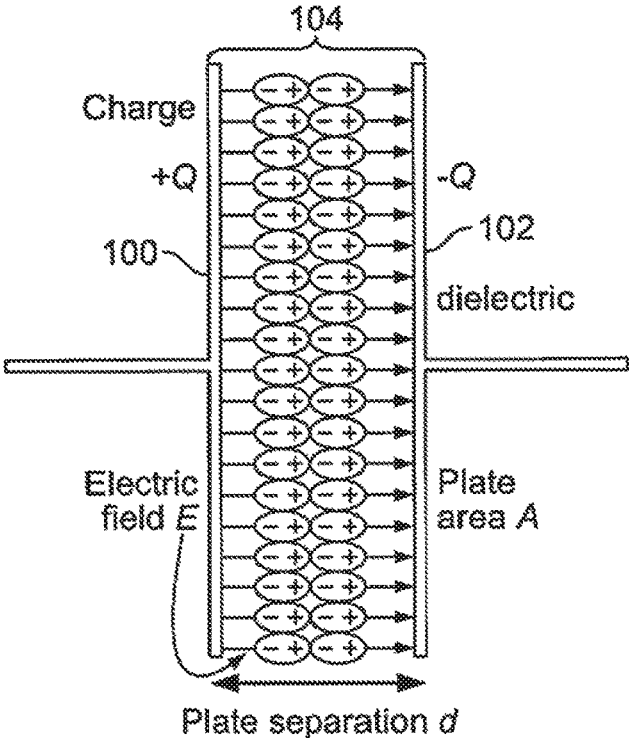
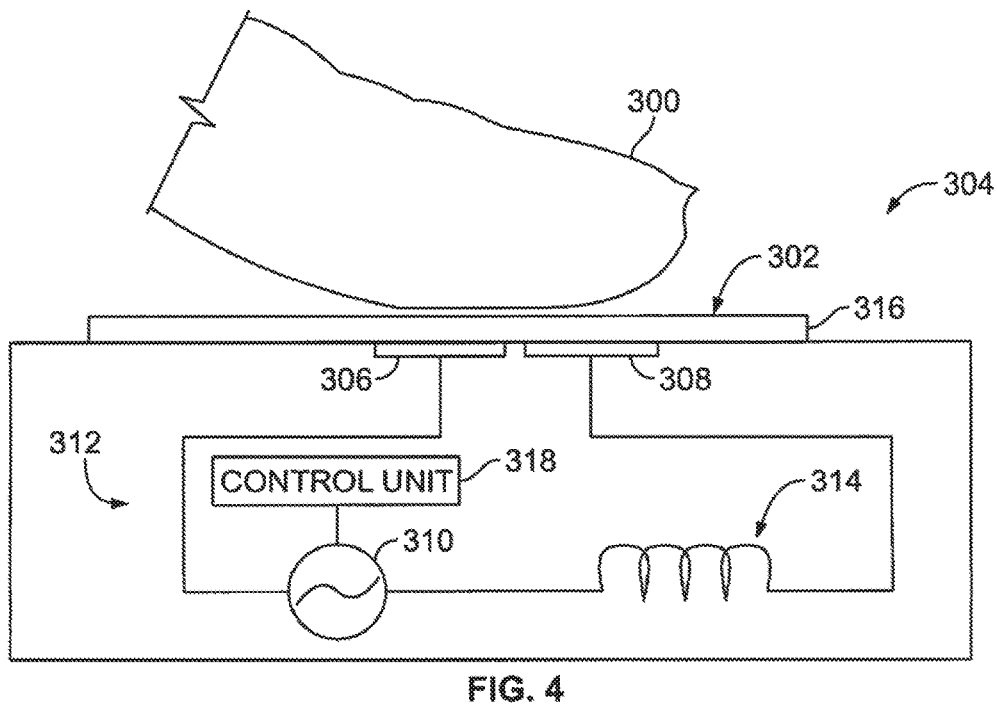
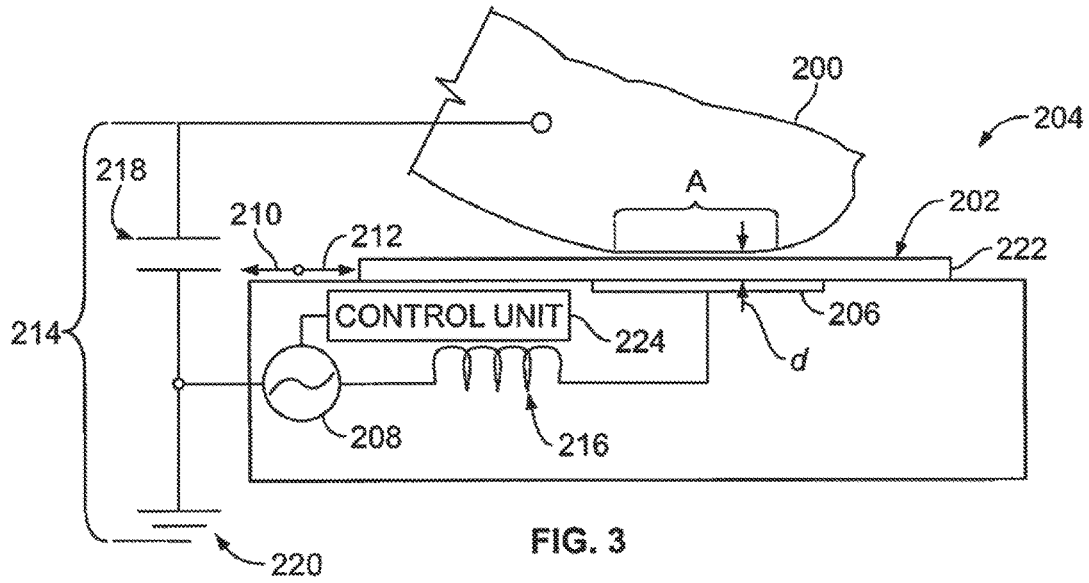

FIG. 2



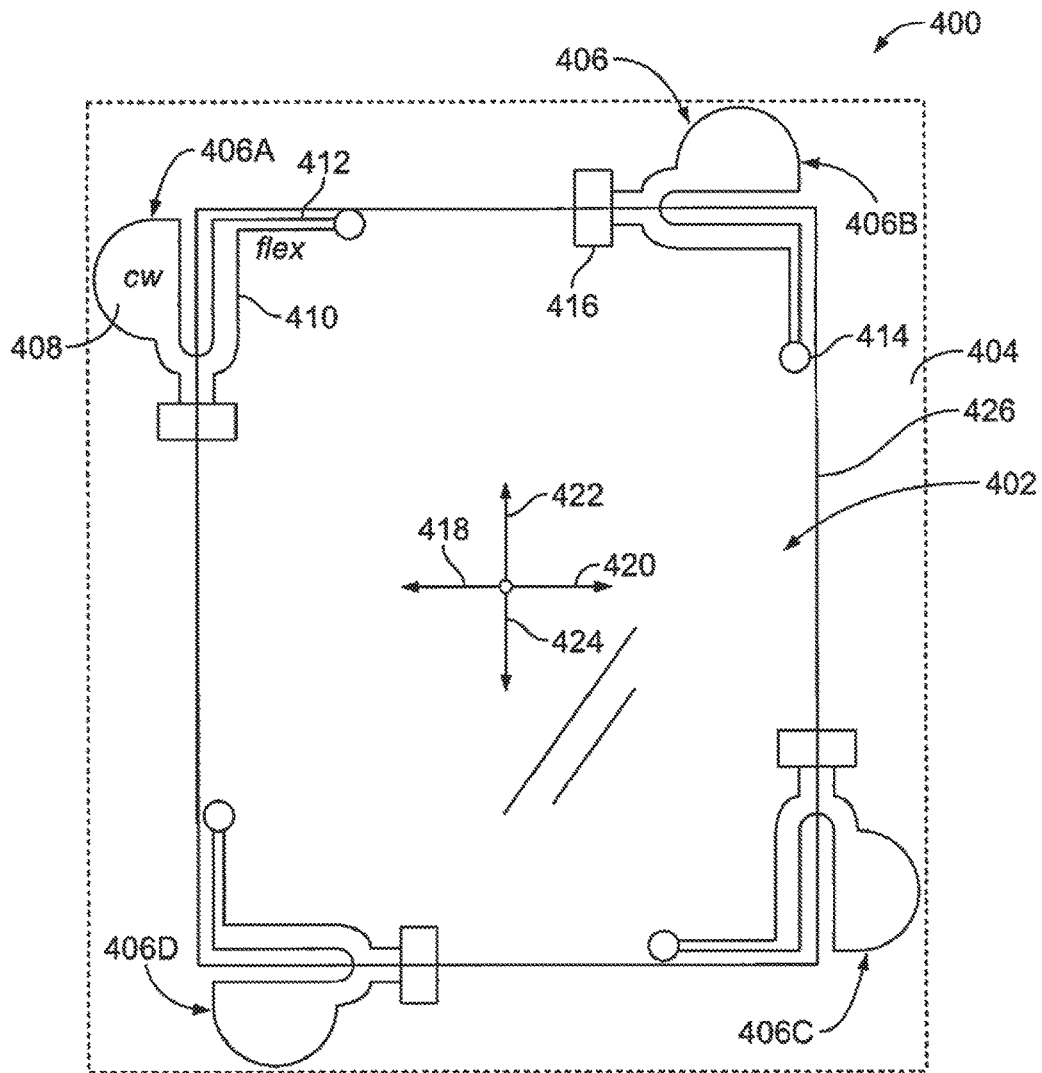

FIG. 5

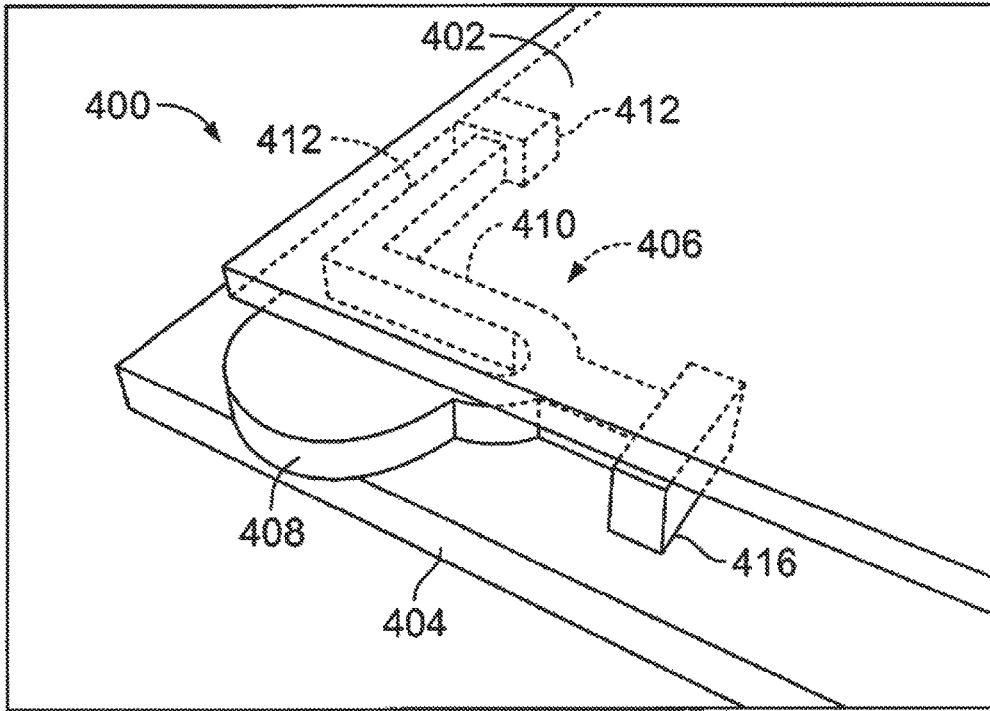

FIG. 6

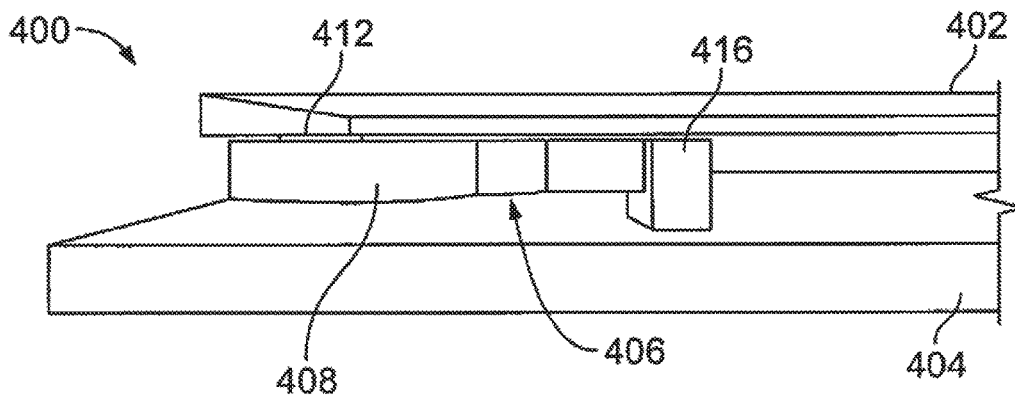

FIG. 7

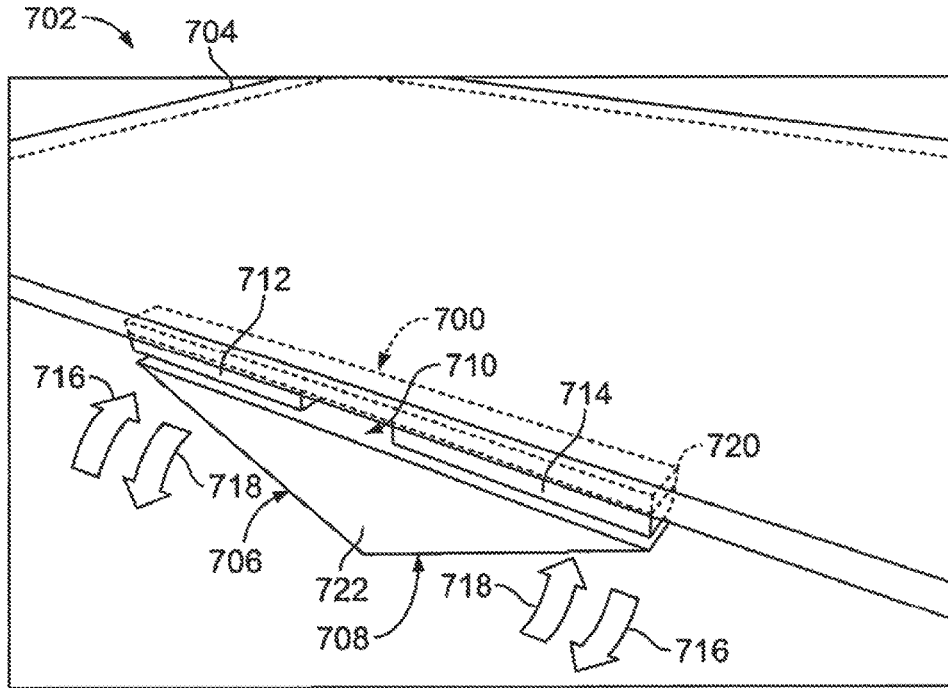

FIG. 8

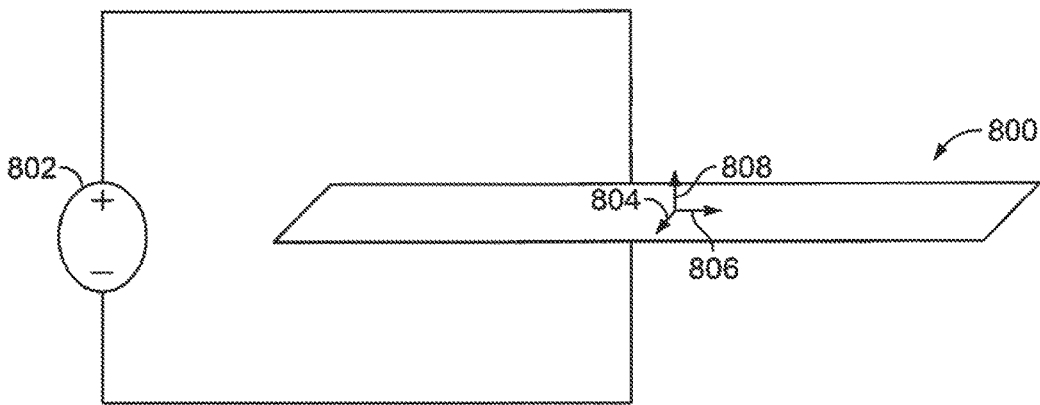

FIG. 9

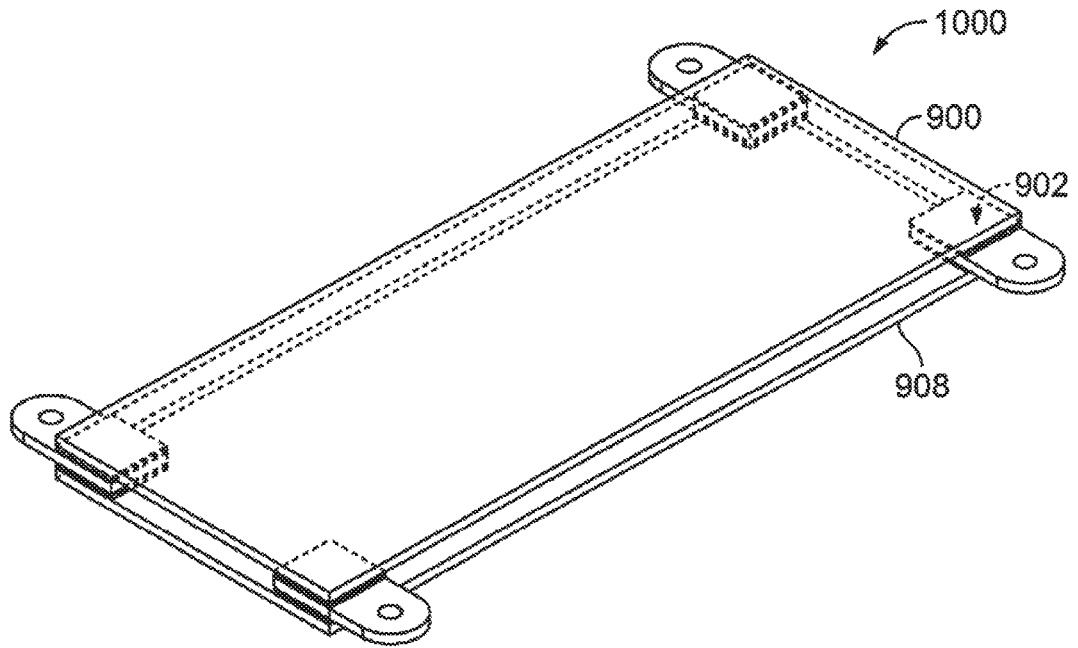

FIG. 10

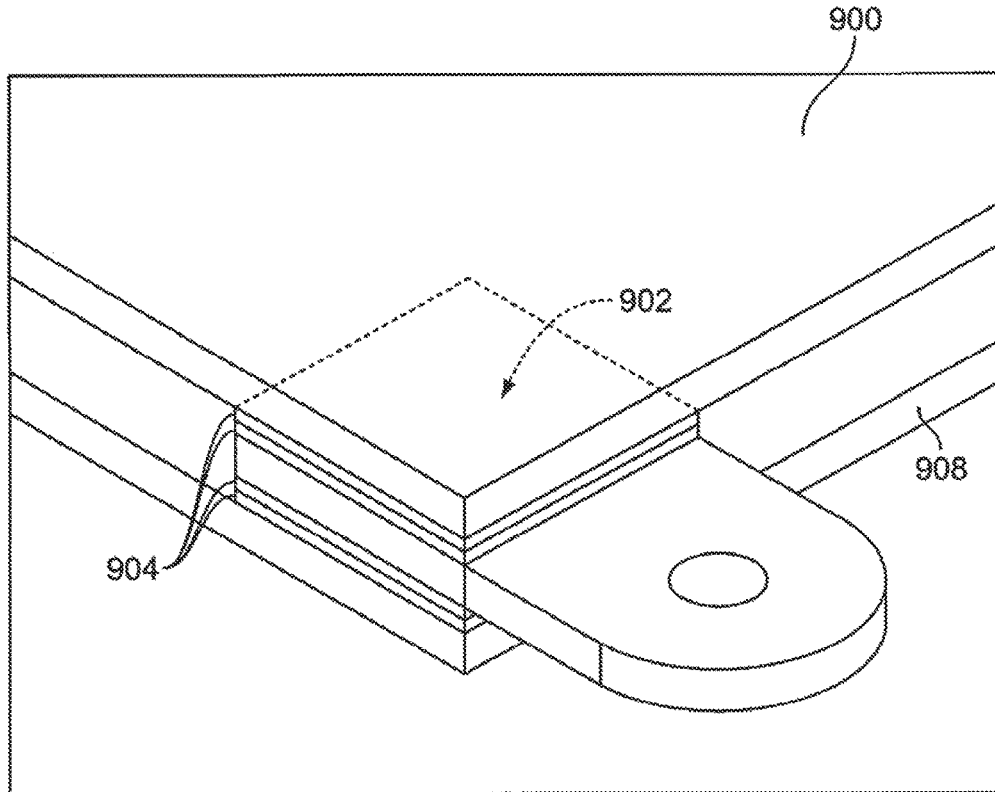

FIG. 11

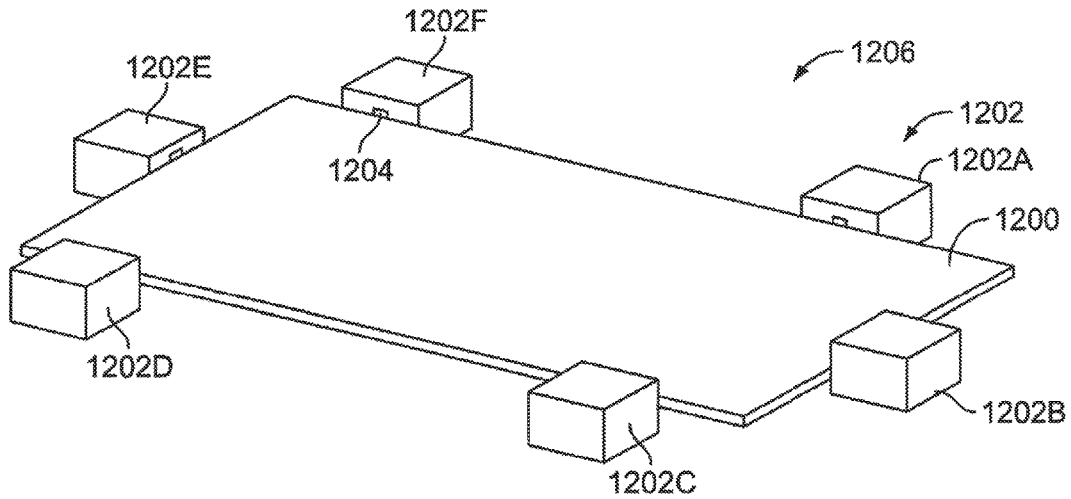

FIG. 12

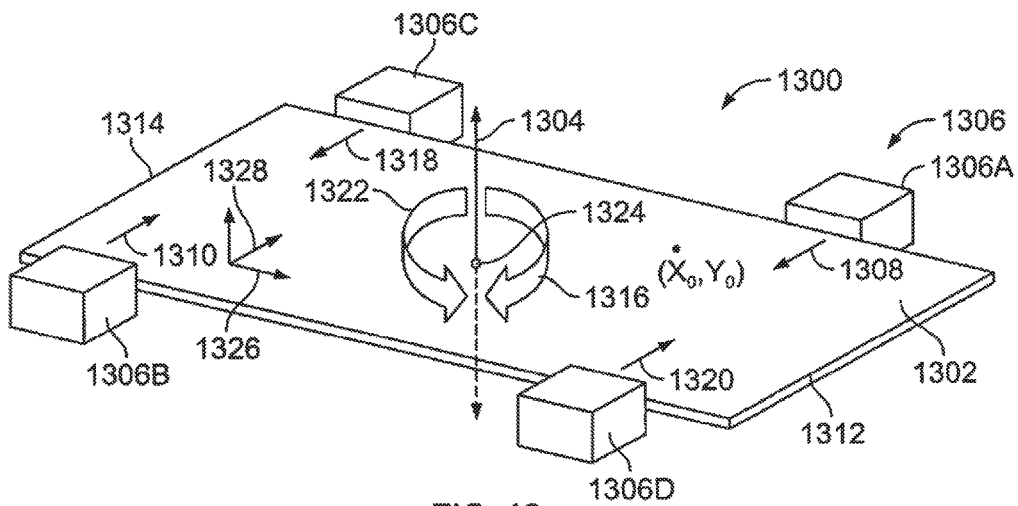

FIG. 13

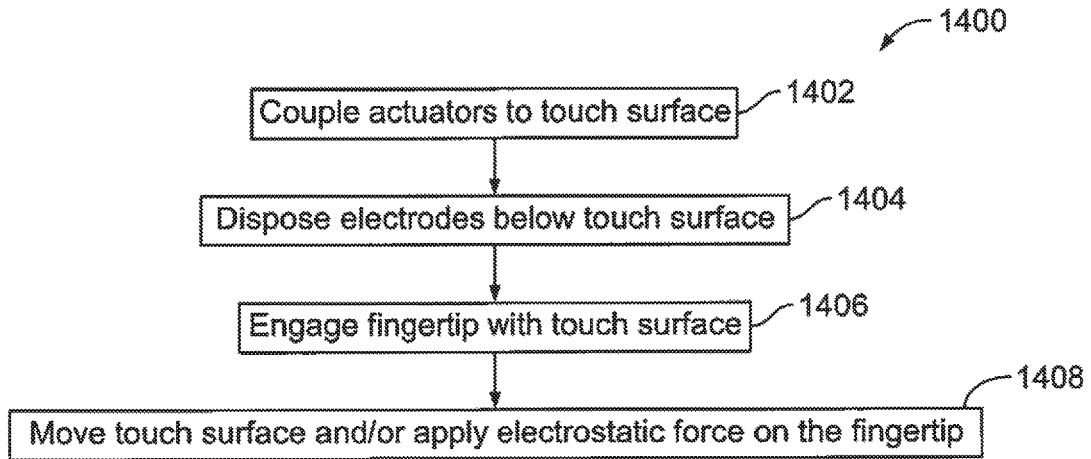

FIG. 14

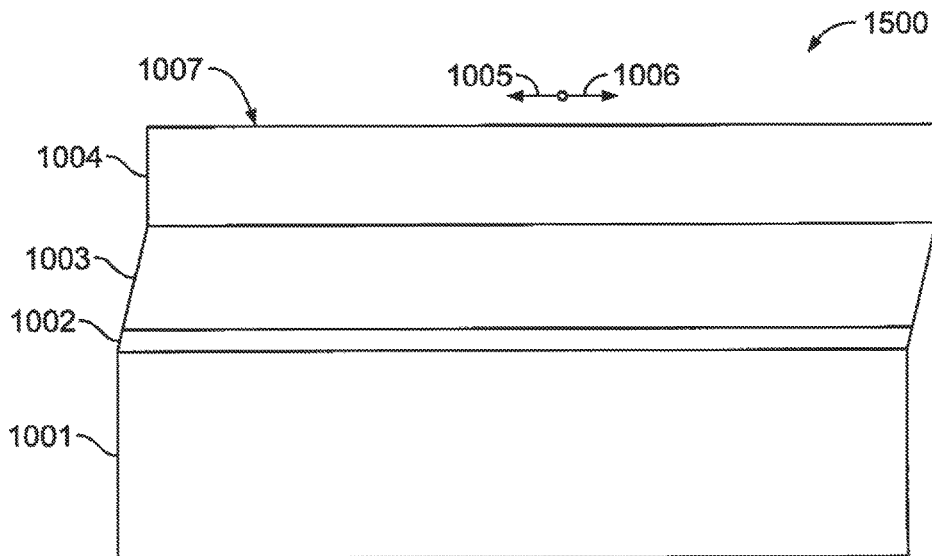

FIG. 15

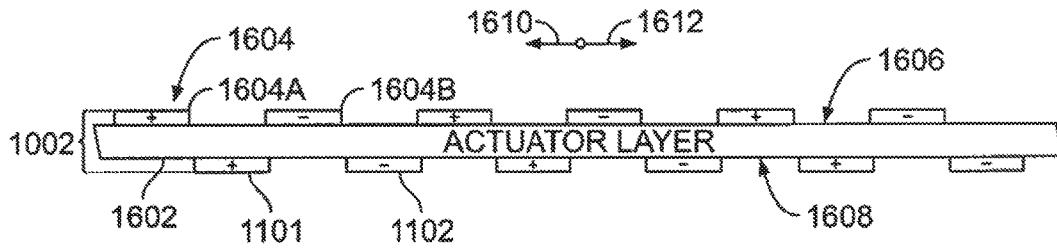

FIG. 16

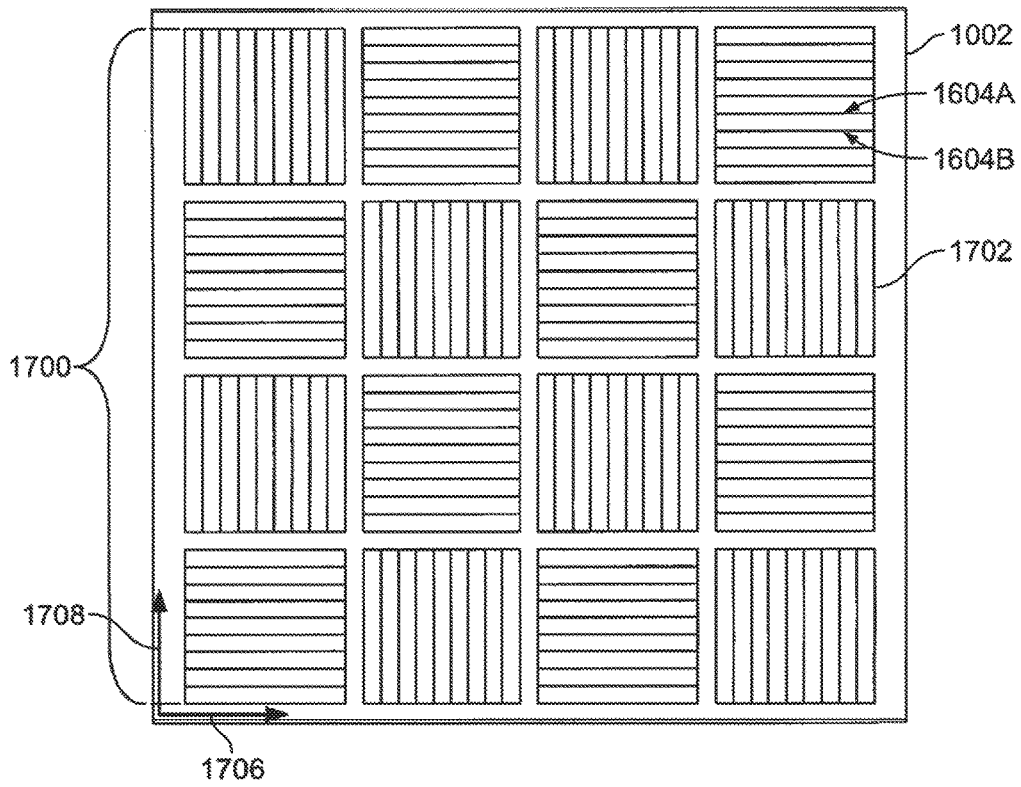

FIG. 17

**TOUCH INTERFACE DEVICE AND
METHOD FOR APPLYING CONTROLLABLE
SHEAR FORCES TO A HUMAN APPENDAGE**

CROSS-REFERENCE TO RELATED
APPLICATIONS

This application is a continuation in part of U.S. application Ser. No. 14/734,868 filed on Jun. 9, 2015, which is incorporated by reference herein in its entirety which is a continuation-in-part of U.S. application Ser. No. 13/468,695 filed on May 10, 2012, which claims benefit and priority of U.S. provisional application No. 61/484,544 filed May 10, 2011, which claims benefit and priority of U.S. provisional application No. 61/484,564 filed on May 10, 2011.

STATEMENT REGARDING FEDERALLY
SPONSORED RESEARCH OR DEVELOPMENT

This invention was made with government support under grant numbers IIS0941581 and IIS0964075 awarded by the National Science Foundation. The government has certain rights in the invention.

BACKGROUND

Touch interface devices can include computing devices having touch sensitive surfaces used to receive input from operators of the devices. For example, many smart phones, tablet computers, and other devices have touch sensitive surfaces that identify touches from operators as input to the devices.

Some of these devices have smooth touch surfaces with an approximately constant friction across the entire surface. Some other known devices have the ability to change the friction forces experienced by a fingertip on the surface. The friction forces may be controllably reduced by introducing ultrasonic vibrations perpendicular to the plane of the surface. The vibrations may be mechanically generated using ultrasound transducers (e.g., piezoelectric elements). A limitation of these devices is that friction is a resistive force, meaning that the friction force opposes the motion of the fingertip. Yet other known devices may apply shear forces to the fingertip in a variety of directions, and not just in directions that oppose motion of the fingertip. These devices may generate the forces by synchronizing in-plane vibrations of the touch surface with the gating (e.g., switching) on and off of ultrasonic vibrations that control the magnitude of the friction. Due to the time required to gate on and off ultrasonic vibrations, however, the frequencies at which the in-plane vibrations occur may be limited.

Moreover, mechanically producing the vibrations can generate acoustic noise that can be undesirable. Additionally, the extent of variation of frictional forces that are achievable by the use of mechanical vibrations may be limited.

The shear forces supplied by some of these known devices may be constant or approximately constant across the entire touch surface at any moment of time. For example, these devices may be incapable of providing different shear forces on different fingertips that concurrently or simultaneously touch the same surface of the device.

BRIEF DESCRIPTION

In one embodiment, a touch interface device includes a touch surface, an actuator, and an electrode. The actuator is

coupled with the touch surface and is configured to move the touch surface in one or more directions. The electrode is coupled with the touch surface and is configured to impart a normal electrostatic force on one or more appendages of a human operator that engage the touch surface when an electric current is conveyed to the electrode. Movement of the touch surface by the actuator and the electrostatic force provided by the electrode are synchronized to control one or more of a magnitude or a direction of a shear force applied to the one or more appendages that engage the touch surface.

In another embodiment, a method (e.g., for controlling shear forces applied to an appendage that touches a touch interface device) includes receiving a touch on a touch surface in a touch interface device by one or more appendages of a human operator, moving the touch surface in one or more directions, and applying an electric current to the electrode to impart a normal electrostatic force on the one or more appendages of the human operator. Moving the touch surface and applying the electric current are synchronized to control one or more of a magnitude or a direction of a shear force applied to the one or more appendages that engage the touch surface.

In another embodiment, another touch interface device includes a touch surface, an electrode, and an actuator. The electrode is coupled with the touch surface. The actuator is coupled with the touch surface and is configured to move the touch surface in order to generate a shear force on one or more appendages of an operator that touch the touch surface. The electrode is configured to receive an electric current to impart an electrostatic force on the one or more appendages and a direction and magnitude of the shear force on the one or more appendages are controlled by movement of the touch surface and application of the electrostatic force.

BRIEF DESCRIPTION OF THE DRAWINGS

The subject matter described herein will be better understood from reading the following description of non-limiting embodiments, with reference to the attached drawings, wherein below:

FIG. 1 is a perspective view of a haptic system that includes a touch interface device in accordance with one embodiment;

FIG. 2 is a schematic diagram of electrostatic force between two objects;

FIG. 3 is a circuit diagram of one embodiment of a fingertip engaging a touch surface of an interface device;

FIG. 4 is a circuit diagram of a fingertip engaging another embodiment of a touch surface of an interface device;

FIG. 5 is a top view of another embodiment of a touch interface device;

FIG. 6 is a perspective view of a swirling actuator of the interface device shown in FIG. 5;

FIG. 7 is a side view of the swirling actuator shown in FIG. 6;

FIG. 8 is a perspective view of a swirling actuator of an interface device in accordance with another embodiment;

FIG. 9 is a schematic diagram of a swirling actuator that can be used to create swirling movements of a touch surface of an interface device in accordance with another embodiment;

FIG. 10 is a perspective view of a haptic system that includes a touch surface of an interface device in accordance with another embodiment;

FIG. 11 is a perspective view of mounting tabs coupled with a touch surface shown in FIG. 10 in accordance with one embodiment;

FIG. 12 is a perspective view of a haptic system that includes a touch surface of an interface device in accordance with another embodiment;

FIG. 13 illustrates a haptic system having a touch surface of a touch interface device in accordance with another embodiment;

FIG. 14 is a flowchart of a method for controlling shear forces applied to a human appendage, such as a fingertip;

FIG. 15 is a schematic cross-sectional view of one embodiment of a distributed actuation system for a touch interface device;

FIG. 16 illustrates a cross-sectional view of an actuator layer shown in FIG. 16; and

FIG. 17 illustrates a top view of the actuator layer shown in FIG. 16.

DETAILED DESCRIPTION

In accordance with one or more embodiments described herein, haptic effects can be created in a touch device by modulating shear forces applied to a fingertip as a function of finger location, finger velocity, and/or finger acceleration. The shear forces are controlled by moving (e.g., swirling and/or rotating) a touch surface and/or applying electrostatic forces to the fingertip. The haptic effects can provide an operator of the device with feelings of his or her fingertip being moved, resisted from being moved, or otherwise physically impacted by the touch surface.

For example, to create haptic experiences that are useful and/or interesting, shear forces can be applied to fingertips that correspond to specific actions of the fingertips and/or to specific events occurring under software control. By way of illustration, consider a game in which the fingertips are used both to bat a virtual ball, and to capture the ball displayed on a touch screen of an electronic device. Consider the act of batting the ball with one finger. In this case, the force generated by the methods described here would depend on both the position and velocity of the finger as well as the position and velocity of the simulated ball. The force exerted on the finger by the device might increase when the position of the finger intersects that of the surface of the ball, indicating a collision. The force might also depend on the relative velocity of the finger and the ball, increasing for higher velocities. The force may not be a simple vibration that varies strictly as a function of time, but can be an active force that varies as a function of state variables such as positions, velocities, and accelerations. In the case of “catching” and “holding” the ball, the reaction forces at the two fingers (which can be functions of state variables such as positions and velocities) can point (e.g., be oriented) in approximately opposite directions. As the ball is held, the forces should persist. The force may be neither a simple vibration nor a transient force. One or more embodiments of the subject matter described herein generate persistent forces and/or different forces at different fingers. In the above discussion, it should be apparent that the technology described here has been integrated with means of measuring the position of one or more fingertips, and with means of displaying graphic images (and also audio, since events like batting a ball are often accompanied by sound). There are many techniques for measuring fingertip positions which may be used here. These include, without limitation, resistive, surface capacitive, projected capacitive, infrared, acoustic pulse recognition, and in-cell optical sensing. There are also many techniques for displaying graphic images and audio. Most of these combine easily with the electrostatic normal force modulation described here, but capacitive and

projective capacitive sensing might seem to interfere with the rapidly varying electric fields used in friction modulation. However capacitive and projective capacitance sensing may be done at a much higher frequency, in the megahertz range, with filtering to separate the signals related to capacitive sensing from those resulting from actuation. In another embodiment, actuation of electrodes for producing haptic effects and sensing touch using the same electrodes may be performed using one or more of the embodiments described in the ‘XXX Application, such as with the embodiments described in connection with FIGS. 15 through 19 of the ‘XXX Application. It may be desirable to use the same electrodes for both purposes.

FIG. 1 is a perspective view of a haptic system 100 that includes a touch interface device 10 in accordance with one embodiment. In accordance with one or more embodiments described herein, the system 100 includes a planar, touch interface device 10 that actively applies forces on an appendage (e.g., a fingertip 200 shown in FIG. 3) of a human body that touches a touch surface 12 of the interface device 10. The forces that are applied to the appendage can be used to produce haptic effects that communicate, convey, or otherwise represent information for the operator. In one embodiment, the touch surface 12 may be the surface of a screen or other portion 20 of the device 10 that is exposed (e.g., accessible for an operator to touch). The touch surface 12 of the device 10 includes the top or exposed surface that is touched by an operator. As described below, the touch surface can be an insulating layer that covers electrodes that are coupled to a screen, surface, or other portion of the device 10. Alternatively, the touch surface 12 can be the exposed portion of the screen, surface, or other portion of the device 10, with the electrodes being disposed within the thickness of the touch surface or coupled to a bottom or unexposed side of the touch surface. The surface 12 can be a touch sensitive surface that senses engagement of the surface 12 by appendages of the operator. Alternatively, the surface 12 may not be sensitive to touch. The screen 20 may be a display screen of the interface device 10 that displays images, graphics, videos, and the like, while also sensing touch of the operator. Alternatively, the screen 20 may be a touch surface that does not also visually display images, graphics, videos, and the like. For example, the screen 20 may represent another portion of the interface device 10 that an operator may touch. The interface device 10 includes an outer housing or frame 18 that is coupled with and/or extends around the touch surface 12. This outer housing 18 can represent one or more portions of the interface device 10 that are grasped or handled by an operator, that are affixed to another component or object when mounting or securing the interface device 10. While the discussion herein focuses on a human fingertip as this appendage, it should be understood that other appendages, such as toes, can be used. It is also possible to mount the haptic systems disclosed here to a body surface, such as the forearm or back, for the purpose of conveying haptic information to the body. Additionally, the device 10 may apply forces to one or more other objects that are placed on the surface of the interface device 10. Moreover, while the discussion herein focuses on using glass as the surface of the interface device, alternatively, another type of surface can be used. The interface device 10 can be used as an input device for an electronic component. By way of example only, the interface device 10 may be a touch screen for a mobile phone, tablet computer, another type of computer, a control apparatus for a system (e.g., a touch screen interface to control computerized systems), and

the like. Alternatively, the device **10** may itself represent the phone, computer, or apparatus and the touch surface **12** may represent the touch screen.

In one embodiment, the interface device **10** uses a combination of motion of the touch surface **12** (referred to herein as “swirling”) and modulation of a normal force that is applied onto the fingertip that engages the touch surface **12** to produce a controllable shear force. This shear force may be used to “push” or guide the fingertip in a desired or designated direction along the touch surface **12**. As described below, the swirling motion of the touch surface **12** can involve in-plane vibrations or other movements of the touch surface **12** in one or more directions. The normal force applied to the fingertip may be generated using electrostatic attraction or electrostatic forces. As used herein, the term “electrostatic attraction” refers to electrostatic interaction or forces between two or more bodies, such as the touch surface **12** and a human appendage.

Consider the friction force between a fingertip and the touch surface **12**, assuming that the fingertip and the touch surface **12** are in contact, but moving relative to each other. Let v_{finger} and $v_{surface}$ represent the two-dimensional velocity vectors of the fingertip and of the touch surface **12**, respectively, in the plane of contact between the fingertip and the touch surface **12**, such as a plane that is parallel to or coextensive with the touch surface **12**. According to the Coulomb model of kinetic friction, the friction force acting on the fingertip can be expressed as:

$$F = \mu N \frac{(v_{surface} - v_{finger})}{|v_{surface} - v_{finger}|} \quad (\text{Equation \#1})$$

where F represents a two-dimensional vector of the friction force acting on the fingertip, N represents the normal force pressing the fingertip and the touch surface **12** together, μ is the coefficient of friction of the touch surface **12**, $v_{surface}$ represents a two-dimensional velocity vector of the touch surface **12**, and v_{finger} represents a two-dimensional velocity vector of the fingertip that engages the touch surface **12**.

The magnitude and direction of the force vector (F) that acts on the fingertip may be controlled. In one embodiment, the magnitude and the direction of the force vector (F) can be controlled by moving the touch surface **12** in a swirling motion **16**. The swirling motion of the touch surface **12** may be expressed as a time-changing (x , y) coordinate of a point of interest **14** on the touch surface **12**. The coordinate of the point of interest **14** may be expressed as:

$$(x_o + \delta \cos(\omega_m t), y_o + \delta \sin(\omega_m t)) \quad (\text{Equation \#2})$$

where x_o represents an initial or current x -axis coordinate of the point of interest **14** along the x -axis illustrated in FIG. **1**, y_o represents an initial y -axis coordinate of the point of interest **14** along the y -axis illustrated in FIG. **1**, δ represents an amplitude of the swirling motion **16**, ω_m represents a frequency of the swirling motion **16** (referred to herein as a swirling frequency), and t represents time. The amplitude of the swirling motion **16** may be expressed as a radius or diameter (or other measurement of size) of a circular path taken by the point of interest **14** in a cycle of the swirling motion **16**. In an embodiment, where the swirling motion **16** causes the point of interest **14** to take a non-circular path (e.g., a path of an ellipse, a polygon, or other shape), the amplitude of the swirling motion **16** may be expressed as another measurement of the size of the path taken by the point of interest **14**, with the amplitude increasing for larger

sized paths and decreasing for smaller sized paths. The swirling frequency may be expressed as a number of times that the point of interest **14** moves from a starting location, around the path defined by the swirling motion **16**, and returns to the starting location, per unit time. For example, if the point of interest **14** moves through a circular (or other closed loop) path sixty times per second in the swirling motion **16**, then the swirling frequency may be 60 hertz.

The $v_{surface}$ velocity vector of the touch surface **12** may be expressed as:

$$v_{surface} = \delta \omega \begin{bmatrix} -\sin \omega_m t \\ \cos \omega_m t \end{bmatrix} \quad (\text{Equation \#3})$$

where δ represents the amplitude of the swirling motion **16**, ω_m represents the swirling frequency, and t represents time. If the finger is not moving relative to the touch surface **12** (e.g., v_{finger} is 0), the force vector (F) may be expressed as:

$$F = \mu N \begin{bmatrix} -\sin \omega_m t \\ \cos \omega_m t \end{bmatrix} \quad (\text{Equation \#4})$$

where μ represents the coefficient of friction, N represents the normal force pressing the fingertip and the touch surface **12** together, ω_m represents the swirling frequency, and t represents time. The above expression of the force vector (F) is an equation for a force vector that is rotating at the swirling frequency ω_m .

In order to control the magnitude and direction of the swirling force vector (F), the coefficient of friction (μ) and/or the normal force (N) may be modulated as a function of time. In one embodiment, the swirling frequency (ω_m) may be relatively high, such as by being greater than a response bandwidth of vibration sensitivity in touch (e.g., ~1 kHz) and/or the response bandwidth of hearing (~20 kHz). Making the swirling frequency ω_m greater than the response bandwidth of hearing may allow for silent or at least relatively quiet operation of the device **10**.

The coefficient of friction (μ) may be modulated using ultrasonic vibrations of the touch surface **12**, such as is described in U.S. patent application Ser. No. 11/726,391 (the “391 Application”). The entire disclosure of the ‘391 Application is incorporated by reference. The response bandwidth of friction variation through ultrasonic vibrations of the touch surface **12** may be limited, such as to frequencies of 1 kHz or less. The response bandwidth can be limited due to the time required to build up or decrease the ultrasonic vibrations of the touch surface **12**.

The normal force (N) may be modulated as a function of time using electrostatic attractive forces between the fingertip and one or more conductive electrodes disposed beneath the touch surface **12**, as described below. Modulation of the normal force (N) can occur at a relatively high rate. The normal force (N) can be modulated according to the expression:

$$N(t) = (N_o + 0.5 \Delta N) + 0.5 \Delta N \cos(\omega_e t + \phi) \quad (\text{Equation \#5})$$

where $N(t)$ represents the normal force between the fingertip and the touch surface **12** as a function of time, N_o represents the normal force applied to the fingertip by the human operator’s downward pressure (e.g., an operator-applied component of the normal force), ΔN represents a change in the normal force caused by the electrode beneath the touch surface **12** when the electrode is energized, ω_e represents a

frequency at which the electrode is energized (e.g., the frequency at which the polarity of a voltage applied to the electrode is changed), φ represents a direction of the normal force, and t represents time. The frequency at which the electrode is energized also may be referred to as a switching frequency. The force vector (F) on the fingertip in the plane of the touch surface **12** may now be expressed as:

$$F = \mu(N_o + 0.5\Delta N) + 0.5\Delta N \cos(\omega_s t + \phi) \begin{bmatrix} -\sin\omega_s t \\ \cos\omega_s t \end{bmatrix} \quad (\text{Equation \#6})$$

If the energizing frequency (ω_s) is relatively high, the force vector (F) may be expressed as a time average of the above expression. For example, the fingertip may be able to respond only to the average force because the remaining changes in the force vector (F) may occur too fast for the fingertip to respond. The time average force is may be expressed as:

$$F = \frac{\mu\Delta N}{4} \begin{bmatrix} \sin\phi \\ \cos\phi \end{bmatrix} \quad (\text{Equation \#7})$$

where F represents the force vector acting on the fingertip having an amplitude of

$$\frac{\mu\Delta N}{4}$$

and pointing in a direction φ relative to the positive y-axis of the touch surface **12** (e.g., in the plane of the touch surface **12**). The force vector (F) can represent shear forces that are applied to the fingertip in the plane of the touch surface **12**. The amplitude of the force vector on the fingertip may be controlled by changing ΔN and the direction of the force vector on the fingertip may be controlled by changing φ .

In order to change the amplitude of the force vector (F), motion of the touch surface **12** can be synchronized with variation of the normal force acting between the fingertip and the touch surface **12**. One way to control normal force is by modulating electrostatic attraction between the fingertip and one or more electrodes disposed below the touch surface **12**. The electrostatic attraction can be used to increase an electrostatic normal force between the fingertip and the touch surface **12**.

The interface device **10** can change the electrostatic normal force by changing electric energy that is supplied at or near the touch surface **12**. For example, the interface device **10** can alter a voltage and/or turn a direct current on or off to change the electrostatic normal force. Varying the electrostatic normal force between the fingertip and the touch surface **12** can reduce the amount of audible noise generated by the device relative to other devices that use mechanical techniques. For example, relative to other interface devices that use ultrasonic transducers, modulating the normal force by changing an electric energy can produce little to no audible noise.

In one embodiment, changes to the supplied electric energy can occur at higher frequencies relative to devices that use mechanical techniques alone. As a result, changes to the supply of electric energy of one or more embodiments

described herein can be varied at frequencies that are ultrasonic frequencies, or other frequencies that are beyond audible.

The swirling motion **16** of the touch surface **12** may be large enough that a velocity of the touch surface **12** exceeds a velocity at which the fingertip is moved on the touch surface **12**. For example, the swirling motions or vibrations of the touch surface **12** may move the touch surface **12** at velocities of at least 10 centimeters per second (cm/s), although slower or faster velocities may be used. The frequency and amplitude at which the touch surface **12** is moved in the swirling motions or vibrations **16** may be varied and kept relatively small in order to allow relatively small mounting and sealing options for the touch surface **12**. For example, with vibration frequencies of 1 kiloHertz (kHz), the vibration amplitudes may need to be at least 16 micrometers (μm) or larger. However, increasing the vibration frequencies up to 20 kHz or larger can reduce the vibration amplitudes to 0.8 μm or smaller.

In one embodiment, the interface device can vary the shear force, or the force vector (F), differently for two or more fingertips or other appendages that concurrently or simultaneously engage the touch surface **12**. For example, changes in the shear forces or force vectors (F) can be controlled separately for each finger by separately controlling the electrostatic normal force on each finger.

FIG. **2** is a schematic diagram of electrostatic force between two objects. The electrostatic force between two objects, such as between a fingertip and the touch surface **12** of the interface device **10** shown in FIG. **1** can be modeled as a parallel plate capacitor device **104**. For example, in the illustrated example, a first object **100** can represent an electrode disposed on the touch surface **12** (and covered by an insulating or dielectric layer), below the touch surface **12** of the interface device **10** (e.g., inside the interface device **10** and on one side of the surface **12**), or within a thickness of the touch surface **12**. A second object **102** can represent a fingertip of a user that engages the touch surface **12**. The objects **100**, **102** are separated by a separation distance (d), which can include or represent the thickness dimension of the touch surface **12**. An electric potential difference, or voltage, (V) is applied to create an electric field (E) between the objects **100**, **102**. The electric field (E) is related to the potential difference (V) across the objects **100**, **102** divided by the separation distance (d). The dielectric constant may be assumed to be constant across the separation distance or may vary.

In one embodiment, the length across the objects **100**, **102**, or the surface area of interaction between the objects **100**, **102**, is relatively large compared to the separation distance (d). For example, the surface area of the object **100** that overlaps the surface area of the object **102** on opposite sides of the touch surface **12** may be relatively large compared to the separation between the objects **100**, **102**. The electrostatic normal force (F) between the objects **100**, **102** may be modeled as a parallel plate capacitor based on the following relationship:

$$F = \frac{\epsilon\epsilon_oAV^2}{2d^2} \quad (\text{Equation \#8})$$

where F represents the electrostatic normal force exerted on the object **102**, ϵ represents the relative permittivity (also known as the dielectric constant) of the touch surface **12** (and/or other components located in the separation distance

between the objects **100**, **102**), ϵ_0 represents the permittivity of free space (8.85×10^{-12} Farads per meter), A represents the surface area of interface between the objects **100**, **102** (e.g., the overlap of the objects described above), V represents the potential difference across the objects **100**, **102**, and d

represents the separation distance between the objects **100**, **102**. With respect to Equations 1, 4, 5, 6, and 7, the electrostatic normal force (F) may represent the normal force (N or N_0).
The electrostatic normal force (F) may be estimated by assuming that the dielectric constant (E) is 5, the surface area (A) is 1×10^{-4} square meters (m^2), and the separation distance (d) is 1×10^{-5} meters (m). Alternatively, other values may be used. For a potential difference (V) of 150 volts, the electrostatic normal force is approximately 0.5 Newtons. The coefficient of friction of skin on glass may be approximately unity, although the coefficient may be more or less depending on factors such as surface finish. As a result, average lateral forces of about 0.25 Newtons may be applied to the finger that touches the surface.

The electric field associated with the above parameters is $E=V/d=1.5 \times 10^7$ Volts per meter (V/m), which may be less than the breakdown strength of many insulators that may be used to form the touch surface **12**, such as parylene (2.8×10^8 V/m). Thus, even higher electric field strengths than 1.5×10^7 V/m may be feasible without exceeding the breakdown strength of the touch surface **12**.

The electrostatic normal force between a fingertip and the touch surface **12** may increase with increasing frequencies at which the polarity of the voltage applied to generate the electric field is switched (e.g., the switching frequency ω_s). The electrostatic normal force may increase with increasing switching frequency due to leakage or flow of electrostatic charges on the fingertip to the touch surface **12**. For example, as the electrostatic charges flow to the touch surface **12** from the fingertip, the attractive force on the fingertip can decrease. The time required for the charges on the fingertip to migrate to the touch surface **12** can be about 200 microseconds (μs). For example, there may be appreciable electrostatic normal force on the fingertip for only about 200 μs before the normal force decreases due to charge leakage. After this time period, the normal force may significantly decrease unless the polarity of the voltage applied to generate the electric field is switched. For example, the normal force may decrease unless the voltage is frequency switched, such as from +150V to -150V. The time period before the normal force decreases due to charge leakage can vary based on the physical condition of the fingertip. For example, for relatively dry skin, the time period may decrease to 50 μs .

In order to avoid or reduce the leakage of charge from the fingertip to the touch surface **12** (and an accompanying decrease in the electrostatic normal force), the polarity of the voltage applied to generate the electric field may be changed or switched at fairly high frequencies, such as frequencies of at least 500 Hz, but preferably greater than 5 kHz. In one embodiment, a switching frequency of at least 50 kHz is used. Alternatively, a different switching frequency may be used.

FIG. 3 is a circuit diagram of one embodiment of the fingertip **200** engaging a touch surface **202** of a touch interface device **204**. The interface device **204** may be similar to (e.g., represent) the interface device **10** shown in FIG. 1. The touch surface **202** may represent a dielectric layer that is disposed on a conductive electrode **206** of the device **204**. For example, the electrode **206** may be coupled to a first side of the touch surface **12** of the device **204** that

faces the operator during use of the device **204**. As described above, the touch surface **202** may represent one or more insulating layer that are disposed on the electrode **206** such that the electrode **206** is disposed beneath the insulating layer(s). In one embodiment, an insulating layer on the electrode **206** may include a layer of hafnium oxide that is one micron thick. Alternatively, another material and/or thickness may be used. In another embodiment, the electrode **206** may be disposed within the thickness of a screen, surface, or other portion of the device or below the screen, surface, or other portion such that the touch surface **202** represents the screen, surface, or other portion of the device that is disposed above the electrode **206** and that is exposed for touching by the operator.

While only a single electrode **206** is shown, several electrodes **206** may be provided, with the different electrodes **206** extending below different areas of the touch surface **202**. A power source **208**, such as an internal battery of the device **204** or a power source electronically derived from a battery or other source, is conductively coupled with the electrode **206** to supply voltage to the electrode **206**. As described above, the voltage can be applied at a switching frequency in order to change an electrostatic normal force between the fingertip **200** and the touch surface **202**. A control unit **224** is disposed within the interface device **204** in the illustrated embodiment. The control unit **224** can represent logic (e.g., software and/or hard-coded instructions) and/or associated circuitry (e.g., one or more processors, controllers, and the like) that controls application of electric energy (e.g., current) from the power source **208** to the electrode **206**. The control unit **224** may control the switching frequency at which the current is applied to the electrode **206** autonomously and/or based on operator input (e.g., based on input received through touch input from the operator).

The interaction of the fingertip **200** and the electrode **206** may be modeled as a parallel plate capacitor. The capacitance of the parallel plate capacitor can be expressed based on the following relationship:

$$C = \frac{\epsilon \epsilon_0 A}{d} \quad \text{(Equation \#9)}$$

where C represents the capacitance, E represents the dielectric constant of the touch surface **202**, ϵ_0 represents the permittivity of free space, A represents the surface area of interface between the fingertip **200** and the touch surface **202**, and d represents the separation distance between the fingertip **200** and the electrode **206**. Using the same parameters described above in connection with FIG. 1, Equation #9 yields a capacitance of 442 picoFarads (pF). Alternatively, another capacitance may be derived from Equation #9. When the power source **208** supplies voltage that is switched at a switching frequency of 10 kHz, an impedance of the capacitor is 36 KiloOhms (Ku), and if the capacitor is excited at 150 V, the reactive current is 4 milliAmps (mA).

The power consumption of the capacitor may be relatively low since the electric field does no real work on the fingertip **200**. The power losses may be limited due to the finite conductivity of the electrode **206** and the fingertip **200**. For example, if the electrode **206** is assumed to have a conductivity of 1 kiloOhms ($k\Omega$) (transparent conductors such as ITO typically exhibit resistivities of 50-200 Ω /square) and 150 V is supplied to the electrode **206**, then the electrode **206** may only dissipate 16 milliWatts (mW).

In order to generate relatively high voltages from the power source 208, a resonant circuit 214 may be formed. The circuit 214 includes an inductive element 216 (e.g., an inductor) placed in series with a capacitor 218 and the power source 208. The capacitor 218 can represent the effective capacitance provided by the capacitor formed by the fingertip 200 and the electrode, and additional capacitance of other electrodes 206 that are excited by the power source 208, but are not disposed opposite of the fingertip 200. The capacitance of the capacitor 218 can be based on a variety of one or more other factors, including the capacitance of the fingertip 200 to a ground reference 220, the capacitance of the skin of the fingertip 200, and/or the capacitance of the touch surface 202. The circuit 214 can be an LC resonant circuit that, when tuned to the frequency of excitation or the switching frequency of the electrode 206, can provide a gain in the voltage supplied by the power source 208 to the electrode 206. Alternatively, another technique of generating higher voltage, such as an electrical transformer or a voltage ladder, may be used.

The swirling motion of the touch surface 12 (e.g., disposed below the electrode 206) may also move the electrode 206 and the touch surface 202. This motion may be provided by moving the touch surface in opposite lateral directions (in and out of the page of FIG. 2) and in opposite transverse directions 210, 212. A swirl may include the movement of the touch surface in a first lateral direction, then in a first transverse direction 210, then in a second lateral direction that is opposite of the first lateral direction, then in the second transverse direction 212. The time period required for moving the touch surface in a looped path (e.g., the time period required for moving a single point on the touch surface in a circular path or a generally ringed path) may be referred to as a swirl period. The term swirl is used here even for motions that are degenerate shapes with zero spatial area, or are spatially asymmetric, or are not strictly periodic. The time period over which voltage is supplied to the electrode 206 may be referred to as an excitation period. In one embodiment, the excitation period is based on the swirl period. For example, the electrostatic normal force between the fingertip 200 and the electrode 206 may be increased when the excitation period is one half of the swirl period. Alternatively, a longer or shorter excitation period may be used.

FIG. 4 is a circuit diagram of a fingertip 300 engaging another embodiment of a touch surface 302 of an interface device 304. Similar to as described above, the touch surface 302 can represent the surface of the device that is touched by an operator, such as an insulating layer disposed above electrodes 306, 308 or a portion of a screen, surface, or other portion of the device 304 that is exposed above the electrodes 306, 308 to accept touch from the operator.

A plurality of conductive electrodes 306, 308 is disposed below the touch surface 302. While only two electrodes 306, 308 are shown, additional electrodes 306, 308 may be provided, with the different electrodes 306, 308 extending below different areas of the touch surface 302. A power source 310, which may be driven by an internal battery of the device 304, is conductively coupled with the electrodes 306, 308 to supply voltage to the electrodes 306, 308. As described above, the power source 310 can provide voltage to the electrodes 306, 308 at a switching frequency to change an electrostatic normal force between the fingertip 300 and the touch surface 302. A control unit 318 is disposed within the interface device 304 in the illustrated embodiment. The control unit 318 can represent logic (e.g., software and/or hard-coded instructions) and/or associated circuitry (e.g.,

one or more processors, controllers, and the like) that controls application of electric energy (e.g., current) from the power source 310 to the electrodes 306, 308. The control unit 318 may control the switching frequency at which the current is applied to the electrodes 306, 308 autonomously and/or based on operator input (e.g., based on input received through the touch surface 302).

The interaction of the fingertip 300 with the touch surface 302 in the position shown in FIG. 3 causes the fingertip 300 to form a parallel plate capacitor concurrently or simultaneously with both of the electrodes 306, 308. In order to generate relatively high voltages from the power source 310, a resonant circuit 312 may be formed. The circuit 312 includes an inductive element 314 (e.g., an inductor) placed in series with the power source 310 and the capacitor formed by the fingertip 300 and the electrodes 306, 308. The circuit 312 can be an LC resonant circuit that, when tuned to the frequency of excitation or the switching frequency of the electrodes 306, 308, can provide a gain in the voltage supplied by the power source 310 to the electrodes 306, 308.

In another embodiment, one or more other circuits or methods may be used to supply relatively high voltage from the power source. For example, one or more transformers and/or voltage ladders may be included in the circuit 214 and/or 312. As described above, the switching frequency at which the power source 208, 310 switches the polarity of the voltage supplied to the electrodes 206, 306, 308 may be half of the swirling frequency of the touch surface 302. For example, because both positive and negative voltages generate electrostatic attractive force between the fingertip 300 and the electrodes 206, 306, 308, the switching frequency may be cut in half relative to the swirling frequency in order to generate electrostatic attractive forces only once during a cycle.

If, in a given application, it is desirable to resist the motion of the fingertip 200, 300 across the touch surface 202, 302 rather than push the fingertip 200, 300 in some direction, voltage can be applied to the electrodes 206, 306, 308 throughout an entire swirl period and/or the touch surface 202, 302 may not be swirled.

During the swirling motion of the touch surface, points on the touch surface 202, 302 may execute relatively small-amplitude circular motions about axes that are normal to the touch surface. For example, if (x_o, y_o) represent coordinates of a point on the touch surface when the touch surface is at rest, then the coordinates of the same point (e.g., the point of interest 14 shown in FIG. 1) during the swirling motion may be represented as:

$$(x_o + \delta \cos(\omega t), y_o + \delta \sin(\omega_m t)) \quad (\text{Equation \#10})$$

where x_o represents an initial position of the point of interest 14 along a first axis disposed in the plane of the touch surface 12, 202, 302 (e.g., the x-axis shown in FIG. 1), y_o represents an initial position of the point along a different, second axis that is perpendicular to the first axis and that is disposed in the plane of the touch surface 202, 302 (e.g., the y-axis shown in FIG. 1), δ represents the amplitude of the swirling motion, ω represents the frequency of the swirling motion (e.g., the swirling frequency), and t represents time.

A variety of different actuation assemblies may be used to create the swirling motion of the touch surface 12. For example, voice coil actuators coupled with the touch surface 12 could be used. As another example, piezoelectric elements may be provided as actuators placed between the touch surface 12 and a frame or housing of the interface device 10, 204, 304 (e.g., the outer housing 18). The

13

actuation assemblies (or “actuators”) may be controlled by a control unit of the interface device, such as the control units 224, 318.

Piezoelectric elements may be composed of hard materials such as quartz or PZT, or of soft or polymeric materials. The disposition of the actuators may along the edges of the touch surface 12, 202, 302, or distributed across the surface of the touch surface 12, 202, 302, and the distribution of the actuators may be uniform or intermittent.

FIG. 5 is a top view of another embodiment of a touch interface device 400. FIG. 6 is a perspective view of a swirling actuator 406 of the interface device 400 shown in FIG. 5. FIG. 7 is a side view of the swirling actuator 406 shown in FIG. 6. The device 400 may be similar to one or more of the interface devices described above, such as the devices 10, 204, 304 shown in FIGS. 1, 3, and 4. The device 400 may use a swirling motion of a touch surface 402 of the device 400 and/or electrostatic forces to change a surface friction of the touch surface 402. The device 400 includes an outer housing or frame 404 that extends around a screen 426, similar to the outer housing or frame 18 (shown in FIG. 1). The touch surface 402 may be similar to the touch surface 12 shown in FIG. 1. The frame 404 is shown in phantom view in FIG. 4. The frame 404 may comprise a portion of the exterior of the device 400. The screen 426 may be a display or other touch sensitive portion of the device 400.

The device 400 includes the actuators 406 that provide a swirling motion to the touch surface 402. The actuators 406 are generally referred to by the reference number 406 and individually referred to by the reference numbers 406A, 406B, 406C, and 406D. While only four actuators 406 are shown, alternatively, a smaller or greater number of actuators 406 may be used.

In the illustrated embodiment, the touch surface 402 is mounted to the frame 404 by the actuators 406. The actuators 406 have a tuning fork shape that includes a bifurcation with two tines 408, 410 and an elongated extension 412 from one of the tines 410. The actuators 406 are coupled with the touch surface 402 by mounts 414 and with the frame 404 by mounts 416. In one embodiment, the actuators 406A and 406C work in concert and the actuators 406B and 406D work in concert to provide the swirling motion.

The actuators 406 may operate similar to tuning forks in that the tines 408, 410 of each actuator 406 can move toward and away from each other. The movement of the tines 410 that are coupled with the touch surface 402 cause movement of the touch surface 402 while the tines 408 act as counterweights to avoid imparting too great of a reaction force on the frame 404. For example, movements of the tines 410 for the actuators 406A and 406C can move the touch surface 402 in opposing lateral directions 418, 420 while movements of the tines 410 for the actuators 406B and 406D can move the touch surface 402 in opposing transverse directions 422, 424. It will be appreciated that other geometries are possible with no obvious visual similarity to one another, but which use the tuning fork principle so that portions of the touch surface and another massive element, compliantly connected to one another, create a resonant system that imparts vibration only modestly or not at all to motions of the frame.

In operation, the tines 408, 410 of each actuator 406 move out of phase with each other so that a reduced reaction force propagates to the frame 404. Unlike an actual tuning fork, however, the tines 408, 410 may not be identical. For example, the tines 410 may be coupled to the touch surface 402 by the extensions 412. Approximately half of the mass of the touch surface 402 is added to the masses of the tines

14

410 and the other half of the mass of the touch surface 402 is added to the tines 408. To achieve balance, the tines 408 are larger (e.g., have greater mass) to form counterweights (cw). The actuators 406A and 406C work together to drive side-to-side movement of the touch surface 402 along the lateral directions 418, 420. The actuators 406B and 406D work together to drive up-and-down movement of the touch surface 402 along the transverse directions 422, 424. The extensions 412 can allow the two axes of motion (e.g., along the lateral directions 418, 420 and along the transverse directions 422, 424) to move simultaneously for swirling of the touch surface 402. Other directions of motion can also be used and it is not necessary that the actuators be specialized to orthogonal directions.

The actuators 406 may be actuated in various ways. For instance, piezoelectric actuators may be laminated to the tines 410, or bending mode piezoelectric actuators may be placed between the tines 408, 410. Alternatively, electrostatic actuation of the tines 408, 410 may be used. The actuators can cause the tines 408 and/or 410 to move and thereby cause the touch surface 402 to move in the lateral directions 418, 420 and/or transverse directions 422, 424 to create the swirling motion of the touch surface 402. In one embodiment, the actuators 406 are individually controlled. For example, the magnitude and/or frequency of movements of the tines 408 and/or 410 of the actuators 406A may differ from the magnitude and/or frequency of movements of the tines 408 and/or 410 of the actuators 406B, 406C, and/or 406D. Also, magnetic actuation can be used, in which either two coils, or a coil and a permanent magnet, create magnetic forces for purposes of actuation.

A control unit (such as one similar to the control unit 224 and/or 318) and power source (such as one similar to the power source 208 and/or 31) may be connected to the piezoelectric actuators, bending mode piezoelectric actuators, and/or electrodes positioned near the actuators 406. The control unit may control application of electric current to the piezoelectric actuators and/or electrodes from the power source to actuate the tines 410. With respect to using electrodes, the control unit may generate an electric field and/or magnetic field using electric current supplied to the electrodes that interact with the tines 410 to electrostatically or magnetically attract or repel the tines 410 in order to control vibration of the actuators 406.

The movements of the actuators 406 may be coordinated or synchronized. For example, the magnitude and/or frequency of movements of the tines 408 and/or 410 of the actuators 406A and 406C may be the same and/or the magnitude and/or frequency of movements of the tines 408 and/or 410 of the actuators 406B and 406D may be the same. The actuators 406 may be arranged in synchronized groups, with the tines 408 and/or 410 of the actuators 406 in each group being synchronized. With respect to the previous example, the actuators 406A and 406C may be in a first synchronized group and the actuators 406B and 406D may be in a different, second synchronized group. In one embodiment, each synchronized group may be responsible for movement of the touch surface 402 in one or more different directions. For example, the first synchronized group of the actuators 406A and 406C may move the touch surface 402 back and forth along the lateral directions 418, 420 and the second synchronized group of the actuators 406B and 406D may move the touch surface 402 back and forth along the transverse directions 422, 424.

FIG. 8 is a perspective view of a swirling actuator 700 of an interface device 702 in accordance with another embodiment. The device 702 may be similar to one or more of the

interface devices described above, such as the device **10** shown in FIG. **1**. For example, the device **702** may use a swirling motion of a touch surface **704** of the device **702** and/or electrostatic forces to change a surface friction of the touch surface **704**. The touch surface **704** may be similar to the touch surface **12** shown in FIG. **1**.

The actuator **700** is coupled with the touch surface **704** and is actuated to create in-plane movements of the touch surface **704**. In the illustrated embodiment, the actuator **700** includes a generally triangular-shaped weight **722** having a plurality of angled surfaces **706**, **708**. The weight **722** is joined with a flexible neck **710** that is coupled with an engagement member **720** coupled with the touch surface **704**. The engagement member **720** may be affixed to the touch surface **704** beneath the area of the touch surface **704** that is engaged by fingertips. The actuator **700** includes electrodes **712**, **714** that receive electric energy, such as voltage, to cause the weight **722** to move and the neck **710** to flex, thereby resulting in a rocking or rotating motion of the weight **722**. For example, voltage is applied to the first electrode **712** by a power source (e.g., via one or more wired connections or electrodes disposed within the device **702**) under control of a control unit (e.g., the control unit **224** and/or **318**) to cause the first electrode **712** to be attracted to or repelled from another component, such as the outer housing of the device, the touch screen, or the like. The first electrode **712** can cause the neck **710** to flex and cause the weight **722** to rotate in a clockwise direction **716**. The voltage can be removed (e.g., no longer supplied) to the first electrode **712** and the voltage can be applied to the second electrode **714** to cause the neck **710** to flex in a different direction and cause the weight **722** to rotate in a counter-clockwise direction **718**. Alternatively, voltage may continue to be applied to both the first and second electrodes **712**, **714**, with the voltage applied to one of the electrodes **712** or **714** being greater than the voltage applied to the other electrode **714** or **712** in order to cause rotation in a corresponding direction, as described above.

The voltages can be applied to the electrodes **712**, **714** at a resonant frequency of the device **702** to create relatively significant movements of the touch surface **704**. The rocking, side-to-side motion of the weight **722** in the clockwise and counter-clockwise directions **716**, **718** may cause reaction forces on the touch surface **704**, which cause the touch surface **704** to move side-to-side. One or more additional actuators **700** can be placed at various points around the periphery of the touch surface **704** to allow for control of movements along opposing lateral directions (e.g., similar to the lateral directions **418**, **420** shown in FIG. **4**) and/or along opposing transverse directions (e.g., similar to the transverse directions **422**, **424** shown in FIG. **4**). The touch surface **704** may be supported on a compliant pad to allowing relatively free movement in the plane of the touch surface **704**.

FIG. **9** is a schematic diagram of a swirling actuator **800** that can be used to create swirling movements of the touch surface **12** of the interface device **10** in accordance with another embodiment. The actuator **800** is a planar or substantially planar body that produces a shearing motion (e.g., movement in one or more directions in the plane of the actuator **800**) when voltage is applied across the actuator **800** by a power source **802**. In one embodiment, the actuator **800** may be a piezoelectric shear plate actuator. The actuator **800** can provide shearing movement while being relatively thin. For example, a 0.5 millimeter thick actuator can produce approximately one micron of displacement in the plane of the actuator **800**. In one embodiment, the actuator **800** may provide motion along a single axis **804**, **806**, or **808**

when voltage is applied to the actuator **800** by the power source **802**. However, additional actuators **800** can be used to permit displacement along two or more axes **804**, **806**, **808**. For example, two actuators **800** can be stacked on top of each other to provide displacement in two orthogonal directions **804** and **806**. A first actuator **800** may be below a second actuator **800**. The first actuator **800** may provide movement (e.g., by expanding or contracting) along the first axis **804** when voltage is supplied by the power source **802** and the second actuator **800** may provide movement (e.g., by expanding or contracting) along the second axis **806** when the same or different voltage is supplied by the same or a different power source **802**.

Alternatively, different portions of the actuator **800** may be polled during fabrication to activate along different axes of motion, for instance in a checkerboard pattern. For example, the actuator **800** may be divided into several portions that each may receive voltage from the power source **802** independent of the other portions. A first portion that receives voltage may move (e.g., contract or expand) while other portions do not move or move in other directions.

FIG. **10** is a perspective view of a haptic system **1000** that includes a touch surface **900** of an interface device (e.g., the interface device **10** shown in FIG. **1**) in accordance with another embodiment. FIG. **11** is a perspective view of mounting tabs **902** coupled with the touch surface **900** in accordance with one embodiment. The touch surface **900** has four mounting tabs **902** coupled with the corners of the touch surface **900**. Alternatively, a different number of the mounting tabs **902** may be coupled with the touch surface **900** and/or the mounting tabs **902** may be coupled elsewhere with the touch surface **900**. The mounting tabs **902** include a plurality of shear plate actuators **904**, such as the actuator **800** shown in FIG. **9**. The different shear plate actuators **904** in a single mounting tab **902** that is disposed at a corner of the touch surface **900** may create displacement of the mounting tab **902** and the touch surface **900** along different directions. For example, a first shear plate actuator **904** may move the touch surface **900** in a first direction (for example, along an x-axis) in the plane of the touch surface **900** while a second shear plate actuator **904** in the same mounting tab **902** may move the touch surface **900** in a second direction (for instance, along a y-axis). A third shear plate actuator **904** may move the touch surface **900** in a third direction along a y-axis in the plane of the touch surface **900** and a fourth shear plate actuator **904** in the same mounting tab **902** may move the touch surface **900** in an opposite fourth direction.

A reaction plate **908** may also be coupled to the actuators **902**. The reaction plate **908** may have the same or approximately the same mass as the touch surface **900**. The reaction plate **908** can assist in reducing or eliminating reaction forces caused by the mounting tabs **902** moving the touch surface **900**. For example, a third and fourth shear plate actuator **904** may move the reaction plate **908** in an opposite direction as the touch surface **900**. By swirling the touch surface **900** and the reaction plate **908** in opposite directions, reaction forces at the four mounting tabs **902** can be reduced or cancelled out. The reaction plate need not necessarily be a complete plate nor identical to the top plate; this was used as an example. The reaction plate may be smaller with more concentrated mass, and it may be broken up into several sections.

The haptic effects created by a touch device that includes the touch surface **900** can be combined with technologies for measuring the position and/or movement of one or more fingertips, and can be combined with graphical and audio

output. For example, the reaction plate **908**, whether the same in properties to the top plate **900** or not, may have another primary purpose in the device as well. For instance, the reaction plate **908** may itself be an LCD or other visual display, or may incorporate projective capacitive finger position sensing, or another type of finger position sensing, or may have both purposes. Because the motions of the top plate **900** and the reaction plate **908** relative to each other may be small (e.g., on the order of microns), the motion may cause little to no disruption to visual or sensing or tactile functions. It can be an objective in the design of devices (e.g., mobile devices), to minimize or significantly reduce thickness and weight, and so a combined purpose for the reaction plate **908** can be advantageous. Similarly, the top plate **900** may have more than one function, for instance it may not only cause lateral forces on a finger, but may also incorporate finger position sensing, or visual display. Use of the top surface **900** as an acoustic speaker surface can also be incorporated into its functions without necessarily interfering with any of its other purposes. The top surface **900** can also be used as an acoustic proximity sensor in order to measure the distance to a user's face or hand or other body part or that the device has been placed in a pocket, which is a determination that has proven to be needed in mobile device applications. Additionally the combination of the top plate **900** and the reaction plate **908** can be used in the production of low frequency vibrations in service of a vibrating alert signal. The reaction plate **908** may be combined with the mechanisms needed for many of the other functions needed in a mobile device.

The number and/or arrangement of the mounting tabs **902** may be adjusted. In particular, it may be useful to place the mounting tabs **902** no farther apart than the wavelength of compression/extension sounds waves at a frequency of interest. Doing this can help to ensure that the entire touch surface **900** moves in unison.

In contrast to one or more of the embodiments described above, the actuators that move the touch surface may be positioned "beneath" the touch surface (e.g., on a side of the touch surface that is opposite of the side that is engaged by the operator). Placing the actuators below the touch surface, as opposed to along the outer edges of the touch surface, can allow for the actuators to be distributed "below" larger touch surfaces than the actuators that may be disposed along outer edges of the touch surface. For example, edge-based actuation that involves the actuators disposed along the outer edges of the touch surface can impose practical limits on the size of the active haptic touch surface. These limitations can occur when high frequencies, for example greater than 20 kHz, are used for the swirling motion of the touch surface. At such high frequencies, materials of the touch surface (such as glass) may not act as a perfectly solid material. Vibration patterns may occur in which one region of the touch surface vibrates out of phase with another region, and in which other regions exhibit only very small vibration amplitudes. The characteristic length over which these effects become important can be based on the wavelength of the sound waves that travel through the touch surface. If the touch surface is glass (speed of sound ~4000 m/sec) and the swirl frequency is 20 kHz, then this wavelength is 3.2 cm.

Because it is often desirable to have considerably larger length and width dimensions to the touch surface, it can be helpful to distribute actuators over much more of the surface instead of placing them strictly at the edges. Distribution of the actuators "below" the touch surface can ensure that regions of the touch surface considerably larger than the wavelength of sound are swirling in synchrony.

FIG. **15** is a schematic cross-sectional view of one embodiment of a distributed actuation system **1500** for a touch interface device. The system **1500** may be used to produce movement, such as swirling movement, of a touch surface of a touch interface device, such as the surface **12** of the device **100** shown in FIG. **1**. In FIG. **15**, a base layer or portion **1001** of the outer housing **18** of the touch interface device is disposed on one side of a distributed actuator layer **1002**. A compliant layer **1003** is disposed on the opposite side of the distributed actuator layer **1002** such that the distributed actuator layer **1002** is between the base portion **1001** and the compliant layer **1003**. The compliant layer **1003** is located between a screen **1004** and distributed actuator layer **1002**. The screen **1004** includes a touch surface **1007**, such as the touch surface **12** described above. In one embodiment, the screen **1004** can be a glass layer that is 0.5 mm thick and the compliant layer **1003** may be a polydimethylsiloxane (PDMS) layer that is 0.05 mm thick. Alternatively, other materials and/or other thicknesses may be used in another embodiment.

The system **1500** can exhibit a shear resonance that results in side-to-side motion along arrows **1005**, **1006** of the touch surface **1007** (e.g., along the x-axis shown in FIG. **1**) at about 20 kHz. Alternatively, the shear resonance may occur at another frequency. Additionally or alternatively, the shear resonance of the screen **1004** may occur in different directions, such as along directions that extend out of and into the plane of FIG. **15** (e.g., along the y-axis shown in FIG. **1**). By exciting this shear resonance along both in-plane axes (x-axis and y-axis) of the screen **1004**, swirling motion of the touch surface **1007** can be produced, similar to as described above in connection with other embodiments. Resonance in the motion of the screen **1004** can have the effect of increasing amplitude of the motion of the screen **1004** relative to the motion of the actuator layer **1002**.

FIG. **16** illustrates a cross-sectional view of the actuator layer **1002** shown in FIG. **16**. The actuator layer **1002** may include a relatively thin, compliant dielectric layer **1602** with a pattern of conductive shear electrodes **1604** (e.g., shear electrodes **1604A**, **1604B**) on both sides **1606**, **1608** of the dielectric layer **1602**. The shear electrodes **1604** on the side **1606** of the layer **1602** may be referred to as a first group of shear electrodes **1604** and the shear electrodes **1604** on the opposite side **1608** may be referred to as a second group of shear electrodes **1604**. Alternatively, the shear electrodes **1604** may be disposed only on one side **1606** or **1608** of the dielectric layer **1602** and not on the opposite side **1608** or **1606**. A control unit (e.g., similar to the control unit **224** and/or **318** shown in FIGS. **2** and **3**) controls application of electric current to the shear electrodes **1604** from a power source (e.g., similar to the power source **208** and/or **310** shown in FIGS. **2** and **3**). In one embodiment, different polarities of voltage are applied to different shear electrodes **1604** to create shear movement of the dielectric layer **1602** and/or in subsets of the dielectric layer **1602**, such as movement along one or more of directions **1610**, **1612** along the x-axis (as shown in FIG. **1**) and/or the y-axis (also as shown in FIG. **1**), such as into and out of the plane of FIG. **16**.

For example, a positive voltage can be applied to the shear electrodes **1604A** and a negative voltage can be applied to the shear electrodes **1604B**. As a result, the positively charged shear electrodes **1604A** repel away from each other and the negatively charged shear electrodes **1604B** repel away from each other. Additionally, the positively charged shear electrodes **1604A** may be attracted toward the negatively charged shear electrodes **1604B**, and vice-versa.

The alternating pattern of shear electrodes **1604** on the sides **1606**, **1608** results in a shear force being generated between the groups of shear electrodes **1604** on the opposite sides **1606**, **1608**. The shear force in turn causes a shear displacement of the dielectric layer **1602**, such as by the side **1606** laterally moving relative to the side **1608** and/or the side **1608** laterally moving relative to the side **1606** along the x-axis and/or the y-axis. The polarity of the voltage applied to the shear electrodes **1604** can be switched at a resonant frequency of the system **1500** to excite a shear movement resonance.

In one embodiment, the dielectric layer **1602** is formed from PDMS and is 10 microns thick. Alternatively, another material and/or thickness may be used. The shear electrodes **1604** can be formed from indium tin oxide (ITO) or silver nanowires such that the shear electrodes **1604** are transparent or light transmissive. Alternatively, the shear electrodes **1604** may be formed from another material. The shear electrodes **1604** can be approximately 100 nanometers thick, 10 microns wide, and separated from one another by 10 micron wide gaps. Alternatively, a different thickness, width, and/or separation distance may be used. The dielectric layer **1602** and the shear electrodes **1604** may be light transmissive to allow for images presented by a display device disposed on an opposite side of the actuator layer **1002** than the screen **1004** to be visible to an operator through the screen **1004**.

FIG. **17** illustrates a top view of the actuator layer **1002** shown in FIG. **16**. The view of FIG. **17** may be a view of the side **1606** or **1608**. The shear electrodes **1604** may be arranged in a checkerboard pattern **1700** across the side **1606**, **1608** of the layer **1002**. Within each subset **1702** (e.g., a square in the illustrated embodiment) of the pattern **1700**, the shear electrodes **1604** may be alternatively arranged, such as by being elongated in different directions, as shown in FIG. **17**. The subsets **1702** may each be approximately 1 cm by 1 cm in size, although other sizes and/or shapes of the subsets **1702** may be used. In order to excite resonance in both the x-axis **1706** and the y-axis **1708**, a designated amount (e.g., half) of the subsets **1702** can be oriented to excite movement (e.g., vibration) of the layer **1002** along the x-axis **1706**, and a remaining or other designated amount (e.g., the remaining half) of the subsets **1702** can be oriented to excite movement (e.g., vibration) of the layer **1002** along the y-axis **1708**. Alternatively, another arrangement of the shear electrodes **1604** may be provided. For example, the shear electrodes **1604** may be arranged in a hexagonal pattern, a lattice pattern (e.g., with the shear electrodes **1604** being elongated and arranged to extend over each other to form the lattice without the shear electrodes **1604** being conductively coupled with each other), and the like.

The pattern of shear electrodes **1604** can be produced using techniques such as photolithography, laser ablation, and the like. It should be understood that the materials, dimensions, and patterns/geometries described here are examples only, and may be replaced with others that produce the same result of swirling motion of the layer **1002** and screen **1004**. In addition, it is not necessary to operate at a resonant frequency, although doing so can be an efficient way to produce the necessary surface motions without excessive actuator effort.

Other approaches to distributed actuation of the screen **1004** are also possible. For instance, a piezoelectric shear plate (e.g., the actuator **800** in FIG. **8**) can be laminated to the base **1001** shown in FIG. **1**. A transparent piezoelectric material such as quartz or Lead-Lanthanum-Zirconate-Ti-

tanate (PLZT) may be used along with transparent electrodes (e.g. ITO or an array of silver nanowires).

In one embodiment, no reaction mass is included in the system **1500** shown in FIGS. **15** through **17**. Instead, the remainder of the device **100** that includes the system **1500** (e.g., the display, electronics, battery, and the like) can provide a reaction mass. The mass of the moving surface (e.g., the screen **1004** and the layer **1003**) can be relatively small compared to the rest of the device **100**, such as the outer housing **18** of the device **100**. Alternatively, a reaction mass could be included in the system **1500**.

FIG. **12** is a perspective view of a haptic system **1206** that includes a touch surface **1200** of an interface device (e.g., the interface device **10** shown in FIG. **1**) in accordance with another embodiment. In the illustrated embodiment, the swirling motion of the touch surface **1200** is provided by coupling rotational motors **1202** (e.g., motors **1202A-F**) to one or more points of the touch surface **1200**. The motors **1202** may carry eccentric loads that create movements in the touch surface **1200** due to reaction forces generated by rotation of the eccentric load. For example, the motors **1202** may be joined with the touch surface **1200** directly or by a shaft or other component **1204** that translates rotation of the eccentric load within the motors **1202** to movement of the touch surface **1200**. These movements can cause a swirling motion of the touch surface **1200**, as described above. Examples of such motors **1202** having eccentric loads can include the vibrator motors in pagers. The rotational speeds of the motors may be at least 20 kiloHertz (kHz) in one embodiment. In one embodiment, the eccentric mass of the motors **1202** may not rotate. Instead, a reaction mass rotor may be moved in a circular displacement motion without rotating, such as by piezoelectric actuation.

Alternatively, the touch surface of the interface device may not move in a swirling motion as described above. For example, a single-axis vibration of the touch surface may be used, with the location of a point on the touch surface represented as:

$$(x_o + \delta \cos(\alpha \sin(\omega_m t)), y_o + \delta \sin(\alpha \sin(\omega_m t))) \quad (\text{Equation \#11})$$

where x_o represents an initial position of the point along a first axis in the plane of the touch surface, y_o represents an initial position of the point along a different, second axis that is perpendicular to the first axis and that is in the plane of the touch surface, δ represents the amplitude of the vibration, ω_m represents the frequency of the vibration, t represents time, and α represents an axis of the single-axis vibration. The axis of the single-axis vibration may be oriented along a desired direction of force that is applied to the fingertip. For example, the axis may be oriented in or parallel to the plane defined by the touch surface, or may be oriented transverse (e.g., perpendicular, acutely, or obliquely oriented) to the plane defined by the touch surface.

In one or more of the previously described embodiments, the swirling motion of the touch surfaces may be planar motions of the touch surface having two degrees of freedom (2dof). For example, several or all points of the touch surface may have the same or approximately the same velocity at the same time, and the touch surface is translated or moved without rotation of the touch surface. While several or all of the points of the touch surface may move along a relatively small circular or other looped path, there may not be rotation of the touch surface about an axis. Instead, the entire touch surface may be moved a designated distance in a first direction along a first axis that lies in the plane defined by the touch surface (e.g., along the x-axis shown in FIG. **1**), then the entire touch surface may be

moved the same or different distance in a different, second direction along a second axis (e.g., along y-axis shown in FIG. 1), then the entire touch surface may be moved the same or different distance in a direction that is opposite the first direction, but along the same first axis (e.g., the x-axis), and then the entire touch surface may be moved the same or different distance in a direction that is opposite the second direction, but along the same second axis to complete the looping swirl movement.

FIG. 13 illustrates a haptic system 1300 having a touch surface 1302 of a touch interface device (such as the interface device 10 shown in FIG. 1) in accordance with another embodiment. The system 1300 provides for rotation of the touch surface 1302 in order to provide a swirling motion. For example, the system 1300 may rotate the touch surface 1302 about (e.g., around) a rotation axis 1304 that is normal to the plane of the touch surface 1302. The system 1300 can include actuators 1306 (e.g., actuators 1306A-D), such as motors, piezoelectric bodies, and the like, that actuate the touch surface 1302 to rotate or at least partially rotate the touch surface 1302 about the rotation axis 1306. For example, first and/or second actuators 1306A, 1306B may push or move the touch surface 1302 in opposite directions 1308, 1310 at or near opposite ends 1312, 1314 of the touch surface 1302 to cause the touch surface 1302 to at least partially rotate around the rotation axis 1304 in a first rotary direction 1316. Third and/or fourth actuators 1306C, 1306D may push or move the touch surface 1302 in opposite directions 1318, 1320 at or near the ends 1314, 1312 of the touch surface 1302 to cause the touch surface 1302 to at least partially rotate around the rotation axis 1304 in an opposite second rotary direction 1322.

Rotating the touch surface 1302 can cause rotation about a fixed point in the plane of the touch surface 1302 with other points in the plane (e.g., or of the touch surface 1302) rotating about the rotation axis 1304. Such a location of the fixed point may be referred to as a Center of Rotation point 1324, or COR point 1324. The location of the COR point 1324 on the touch surface 1302 may be designated as (x_{COR}, y_{COR}) . If the touch surface 1302 is rotated in an oscillatory rotation about the rotation axis 1304 at a frequency ω_r , then motion, or changes in location, at a point of interest (x_o, y_o) of the touch surface 1302 that is different (e.g., spaced apart) from the COR point 1324 may be expressed as:

$$v_{x,y} = (e(y_{COR} - y_o) \sin(\omega_r t) (e(x_o - x_{COR}) \sin(\omega_r t))) \quad (\text{Equation \#12})$$

where e represents a scale factor for amplitude of movement or rotation, x_o represents an initial location of the point of interest (x_o, y_o) along a first axis 1326 in the plane of the touch surface 1302, y_o represents an initial location of the point of interest (x_o, y_o) along a different, second axis 1328 in the plane of the touch surface 1302 and that is perpendicular to the first axis, x_{COR} represents the location of the COR point 1324 along the first axis 1326, y_{COR} represents the location of the COR point 1324 along the second axis 1328, ω_r represents the frequency of oscillation about the COR point 1324, and t represents the time since motion began. The points (e.g., locations on the touch surface 1302) that are disposed farther from the COR point 1324 may experience greater motion amplitudes relative to other points located closer to the COR point 1324. For example, the COR point 1324 may experience little or no motion amplitude while a location on the outer perimeter of the touch surface 1324 may experience significant motion during the same rotation of the touch surface 1302.

Rotary vibrations of the touch surface 1302 can allow the forces experienced by simultaneous touches of the same

touch surface 1302 in different locations to be independently controlled and/or different from each other. For example, a first fingertip that touches the touch surface 1302 at the COR point 1324 may experience little to no force from the rotary vibrations while a second finger that touches the touch surface 1302 at another location that is not at the COR point 1324 can experience a force from the rotary vibrations. As a result, the forces experienced by different fingertips on the same touch surface 1302 can be individually controlled and different from each other.

In one embodiment, rotary vibrations about the COR point 1324 are combined with swirling vibrations or movements described above. For example, rotation about the COR point 1324 of the touch surface 1302 can be combined with swirling movement or vibrations of the touch surface 1302 that move the entire touch surface along a looped path. The frequencies of each movement (e.g., rotation about the COR point 1324 and the swirling motion) can be different from each other. In addition, an electric field may be applied to increase an electrostatic normal force, as described above. The application of the electric field may be synchronized with the swirling motion (e.g., the electric field may be applied at half of the swirling frequency as discussed above). At the COR point 1324, the swirling motion may be the dominant effect that affects the forces on the fingertip as the rotary vibration may apply little to no forces on the fingertip at the COR point 1324. In locations that are disposed away from the COR point 1324, the motion of the touch surface 1302 may not be synchronized with the electric field and, as a result, the average force applied on a fingertip at such locations may be small or zero. This approach can be extended further by producing not just combinations of rotational vibration and swirling, but arbitrary combinations of x motion, y motion, and rotation of the touch surface 1302.

In another embodiment, the touch surface of an interface device can be tiled with electrostatic patches. For example, the touch surface can be patterned into non-overlapping zones, such as a diamond or checkerboard pattern, which can be individually addressed, charged, and discharged with voltage to locally generate electrostatic normal forces at or near the activated zones. The phase relationships between application of the electric fields and the swirling motion may differ from each other. As a result, each zone can apply a force on a fingertip disposed at least partially within the zone to drive the fingertip in a different direction and/or with a different force magnitude than one or more other zones. As one example, a system that includes one or more of the touch surfaces described herein (and/or actuators, motors, and the like) can include the lattice of electrodes shown in described in the '564 Application and/or the 'XXX Application.

In another embodiment, out-of-plane vibrations of the touch surface can be provided. For example, vibrations or movements of the touch surface in directions that are oriented perpendicular or otherwise out of the plane of the touch surface may be provided by one or more of the actuators described above. Instead of or in addition to moving the touch surface within the plane defined by the touch screen (and/or in a parallel plane), the actuators may move the touch screen out of the plane, such as vertically up and down, or toward and away from the operator who is touching the touch surface. These out-of-plane vibrations can be provided at the same frequency that the surface is "swirled." If peaks or changes in the normal force due to the mechanical vibrations caused by swirling and/or out-of-plane vibrations are synchronized with the peaks or

increases in the normal force due to the electric field, then the total normal force between the fingertip and the surface can be increased further.

The various actuators, motors, and the like that are used to control movement of the screens described herein may be controlled by a control unit, such as a control unit **224** and/or **318** shown in FIGS. **2** and **3**. Such a control unit can control the movements created by the actuators, motors, and the like, by communicating control signals to the actuators, motors, and the like, by controlling the flow of electric current to the actuators, motors, and the like, or otherwise directing how the actuators, motors, and the like control movement of the screen.

FIG. **14** is a flowchart of a method **1400** for controlling shear forces applied to a human appendage, such as a fingertip. The method **1400** may be used in conjunction with one or more of the systems, devices, and touch screens described herein. At **1402**, actuators are coupled to a touch surface. For example, one or more of the actuators **406**, **706**, **800**, **902**, **1202**, **1306** may be joined to the touch surface **12**, **202**, **302**, **402**, **702**, **900**, **1200**, or **1302**. At **1404**, one or more electrodes are disposed below the touch surface. For example, one or more of the electrodes **206**, **306**, **308** may be disposed on a side of the touch surface **12**, **202**, **302**, **402**, **702**, **900**, **1200**, or **1302** that is opposite of the side that is touched by an operator. Alternatively, one or more of the electrodes and/or lattices of electrodes shown and/or described in the '564 Application and/or the 'XXX Application may be disposed below the touch surface.

At **1406**, a fingertip or other appendage is engaged with the touch surface. For example, the operator may touch the touch surface to interact with a device that includes the touch surface, such as a mobile phone, computer, input device, and the like. At **1408**, the touch surface is moved and/or electrostatic force is applied to the fingertip or other appendage in order to control shear forces applied to the fingertip. As described above, the movement of the touch surface may be an in-plane swirling motion of the touch surface, an in-plane rotation of the touch surface, an out of plane motion of the touch surface, and the like. Different forces may be applied to different fingertips at different locations on the touch surface, as described above. Additionally, one or more of the forces may be a persistent force (e.g., a force that is applied as long as the fingertip engages the touch surface and/or some visual event that is shown on the touch surface and that is represented by the forces continues).

In another embodiment, a touch interface device includes a touch surface, an actuator, and an electrode. The actuator is coupled with the touch surface and is configured to move the touch surface in one or more directions. The electrode is coupled with the touch surface and is configured to impart a normal electrostatic force on one or more appendages of a human operator that engage the touch surface when an electric current is conveyed to the electrode. Movement of the touch surface by the actuator and the electrostatic force provided by the electrode are synchronized to control one or more of a magnitude or a direction of a shear force applied to the one or more appendages that engage the touch surface.

In one aspect, the movement and electrostatic force are synchronized when a frequency of repeated movements of the touch screen and a frequency of repeated application of the current (e.g., between ON vs. OFF) or switching the polarity (e.g., between positive and negative voltages) are based on each other. Alternatively, the movement and the electrostatic force may be synchronized when the movements and application of current occur at the same frequency.

In one aspect, the actuator is configured to move the touch surface such that a point of interest on the touch surface moves along a path of a loop.

In one aspect, the magnitude of the shear force that is applied to the one or more appendages that engage the touch surface increases with an increasing frequency at which the point of interest moves through the path of the loop.

In one aspect, the magnitude of the shear force that is applied to the one or more appendages that engage the touch surface increases with an increasing voltage applied to the electrode.

In one aspect, the device also includes a control unit configured to control application of the electric current to the electrode at a switching frequency that represents a frequency at which a polarity of the electric current changes. The magnitude of the shear force that is applied to the one or more appendages increases with increasing switching frequency of the electric current.

In one aspect, the actuator is configured to move the touch surface in the one or more directions that are oriented in or parallel to a plane defined by the touch surface.

In one aspect, the actuator is configured to move the touch surface by at least partially rotating the touch surface around a rotation axis.

In one aspect, the actuator is configured to move the touch surface in one or more directions oriented transverse to a plane defined by the touch surface.

In one aspect, the shear force is a non-transitory or non-vibratory force.

In one aspect, the actuator includes first and second tines that move relative to each other. The first tine is coupled with the touch surface and the second tine is decoupled from the touch surface (e.g., is not directly connected with the touch surface). At least one of the first tine or the second tine moves relative to another of the first tine or the second tine to move the touch surface in a back-and-forth direction.

In one aspect, the actuator includes a triangular-shaped weight coupled with the touch surface and one or more actuator electrodes. The actuator electrodes are configured to receive electric current to move the weight relative to the touch surface (e.g., by attracting the actuator electrodes toward or repelling the actuator electrodes from another body, such as the touch surface, a housing of the device, or other body such as a magnet). Movement of the weight causes movement of the touch surface.

In one aspect, the swirling actuator includes one or more piezoelectric actuators that move the touch surface in one or more directions when electric current is applied to the one or more actuators.

In one aspect, the actuator is coupled with the touch surface along one or more of the outer edges of the touch surface.

In one aspect, the actuator is a light transmissive actuator distributed across a side of the touch surface that is opposite of a side of the touch surface to which the electrode is coupled.

In one aspect, the actuator includes an actuator layer that generates shear movement in directions that are parallel to the touch surface and a compliant layer. The compliant layer is disposed between the actuator layer and the touch surface. The shear movement of the actuator layer creates vibratory or resonant movement of the touch surface via the compliant layer.

In one aspect, the actuator includes a dielectric layer having first and second shear electrodes. The first shear electrodes receive an opposite polarity of an electric current relative to the second shear electrodes to cause at least one

of attraction or repulsion between the first and second electrodes to generate shear movement in the dielectric layer. The shear movement in the dielectric layer causes movement of the touch surface in the one or more directions.

In another embodiment, a method includes receiving a touch on a touch surface in a touch interface device by one or more appendages of a human operator, moving the touch surface in one or more directions, and applying an electric current to an electrode coupled to the touch surface to impart a normal electrostatic force on the one or more appendages of the human operator. Moving the touch surface and applying the electric current are synchronized to control one or more of a magnitude or a direction of a shear force applied to the one or more appendages that engage the touch surface.

In one aspect, moving the touch surface includes moving the touch surface such that a point of interest on the touch surface moves along a path of a loop.

In one aspect, applying the electric current includes applying the electric current to the electrode at a switching frequency that represents a frequency at which a polarity of the electric current changes. The magnitude of the shear force that is applied to the one or more appendages increases with increasing switching frequency of the electric current.

In one aspect, moving the touch surface includes at least partially rotating the touch surface around a rotation axis.

In another embodiment, another touch interface device includes a touch surface, an electrode, and an actuator. The electrode is coupled with the touch surface. The actuator is coupled with the touch surface and is configured to move the touch surface in order to generate a shear force on one or more appendages of an operator that touch the touch surface. The electrode is configured to receive an electric current to impart an electrostatic force on the one or more appendages and a direction and magnitude of the shear force on the one or more appendages are controlled by movement of the touch surface and application of the electrostatic force.

In one aspect, the actuator is configured to move the touch surface in a swirling motion such that a point of interest on the touch surface moves along a looped path.

In one aspect, the actuator is configured to at least partially rotate the touch surface around a rotation axis.

In one aspect, the actuator is configured to generate different shear forces on different appendages of the operator that concurrently touch the touch surface based on rotation of the touch surface.

It is to be understood that the above description is intended to be illustrative, and not restrictive. For example, the above-described embodiments (and/or aspects thereof) may be used in combination with each other. In addition, many modifications may be made to adapt a particular situation or material to the teachings of the inventive subject matter described herein without departing from its scope. While the dimensions and types of materials described herein are intended to define the parameters of the inventive subject matter, they are by no means limiting and are exemplary embodiments. Many other embodiments will be apparent to one of ordinary skill in the art upon reviewing the above description. The scope of the subject matter described herein should, therefore, be determined with reference to the appended claims, along with the full scope of equivalents to which such claims are entitled. In the appended claims, the terms “including” and “in which” are used as the plain-English equivalents of the respective terms “comprising” and “wherein.” Moreover, in the following claims, the terms “first,” “second,” and “third,” etc. are used merely as labels, and are not intended to impose numerical requirements on their objects. Further, the limitations of the

following claims are not written in means-plus-function format and are not intended to be interpreted based on 35 U.S.C. § 112, sixth paragraph, unless and until such claim limitations expressly use the phrase “means for” followed by a statement of function void of further structure.

This written description uses examples to disclose several embodiments of the inventive subject matter and also to enable a person of ordinary skill in the art to practice the embodiments disclosed herein, including making and using any devices or systems and performing any incorporated methods. The patentable scope of the subject matter is defined by the claims, and may include other examples that occur to one of ordinary skill in the art. Such other examples are intended to be within the scope of the claims if they have structural elements that do not differ from the literal language of the claims, or if they include equivalent structural elements with insubstantial differences from the literal languages of the claims.

As used herein, an element or step recited in the singular and proceeded with the word “a” or “an” should be understood as not excluding plural of said elements or steps, unless such exclusion is explicitly stated. Furthermore, references to “one embodiment” of the present inventive subject matter are not intended to be interpreted as excluding the existence of additional embodiments that also incorporate the recited features. Moreover, unless explicitly stated to the contrary, embodiments “comprising,” “including,” or “having” an element or a plurality of elements having a particular property may include additional such elements not having that property.

Since certain changes may be made in the above-described systems and methods, without departing from the spirit and scope of the subject matter herein involved, it is intended that all of the subject matter of the above description or shown in the accompanying drawings shall be interpreted merely as examples illustrating the inventive concepts herein and shall not be construed as limiting the disclosed subject matter.

What is claimed:

1. A method of moving a plurality of appendages of an operator in contact with a touch surface, the method including the steps of:

- measuring a plurality of locations when the touch surface is touched by the plurality of appendages;
- moving the touch surface in a swirling motion by one or more actuators coupled with the touch surface;
- controlling a voltage on each of a plurality of electrodes disposed below the touch surface;
- controlling an electrostatic normal force acting on each of the appendages by adjusting the voltage applied to each of the plurality of appendages by each electrode lying beneath the appendage;
- synchronizing the electrostatic normal force generated by the voltage applied to each of the plurality of appendages with the swirling motion by basing a frequency of the swirling motion on the frequency of application of the electrostatic normal force such that a distinct persistent shear force is simultaneously applied to each of the respective plurality of appendages.

2. The method of claim 1, wherein the swirling motion is elliptical.

3. The method of claim 1, wherein the swirling motion is non-circular.

4. The method of claim 1, wherein a change in an electrostatic force is an increase.

5. The method of claim 1, wherein each of the persistent shear forces acts in a different direction.

- 6. The method of claim 1, wherein the sensor uses capacitive sensing.
- 7. The method of claim 1, wherein the sensor uses optical sensing.
- 8. The method of claim 1, wherein the actuator is piezo- 5 electric.
- 9. The method of claim 1, wherein the actuator is electromagnetic.
- 10. The method of claim 1 wherein, the swirling motion occurs at a frequency that is above the bandwidth of tactile 10 perception.
- 11. The method of claim 1, wherein the swirling motion occurs at an ultrasonic frequency.
- 12. The method of claim 1, wherein the swirling motion occurs at a frequency of at least 1 kHz. 15
- 13. The method of claim 1, wherein a reaction plate is coupled to the actuator.
- 14. The method of claim 1, wherein the actuator is a resonant system.
- 15. The method of claim 1, wherein the plurality of 20 electrodes form a lattice pattern.

* * * * *