

Nonholonomic Haptic Display

J. Edward Colgate
Michael A. Peshkin
Witaya Wannasuphprasit

Department of Mechanical Engineering
Northwestern University
Evanston, IL 60208-3111

Abstract

Conventional approaches to haptic interface rely on high gain servos to implement virtual constraints. The role of the servo is to reduce the apparent degrees of freedom in such a way as to effectively constrain a human operator's motion. A significant drawback of this approach, however, is that the operator must interact directly with a high power system that is not inherently passive, and which may become unstable. In this paper, we present a novel approach to haptic display which allows virtual constraints to be implemented in a manner that is completely passive and therefore intrinsically safe. The key idea is to begin with a device having zero or one degree of freedom, and to use feedback control to increase the apparent degrees of freedom as necessary. This becomes possible with the use of nonholonomic joints, which have fewer degrees of freedom than generalized coordinates. The design and feedback control of several "programmable constraint machines" (PCMs) of this type are discussed.

1. Introduction

Haptic displays, which are essentially robots designed for direct, physical interaction with human operators, have a great variety of applications. These range from teleoperation, to virtual reality, to robotic surgery. One of the most exciting capabilities of haptic displays is the implementation of *programmable constraint*. For example, Rosenberg [5] has shown that "haptic virtual fixtures" (hard walls which constrain motion to useful directions) can dramatically improve performance in teleoperation tasks such as remote peg-in-hole insertion. Another example comes from Kelley and Salcudean [3] who describe the "Magic Mouse", a computer interface device which can constrain an operator's hand to useful directions while interacting with a GUI (to avoid, for instance, "slipping off" a pull-down menu). Yet another is a robotic surgery system in which a robot positions a guide (a constraint) for a tool held by a surgeon.

These examples have two rather clear commonalities. One, they all involve constraining the motion of a human operator. Two, the source of energy for carrying out the task is the human operator. Related to the latter is a less obvious point: in all cases, the behavior of the haptic display is, ideally, energetically *passive*. Passivity plays an important role in ensuring the stability of the overall

system, and the safety of the human operator [1]. Experience has shown, however, that when using conventional approaches to haptic display, constraint and passivity are antagonistic goals. This is because conventional approaches employ servo control to reduce the degrees of freedom (d.o.f.) of a multi-d.o.f. robot to those consistent with the programmed constraint. To implement an effective constraint, a servo controller requires high gains which are incompatible with passivity and stability. While there has been considerable progress made in designing haptic displays which admit high gains [1], the problem described is inherent to the servo control approach.

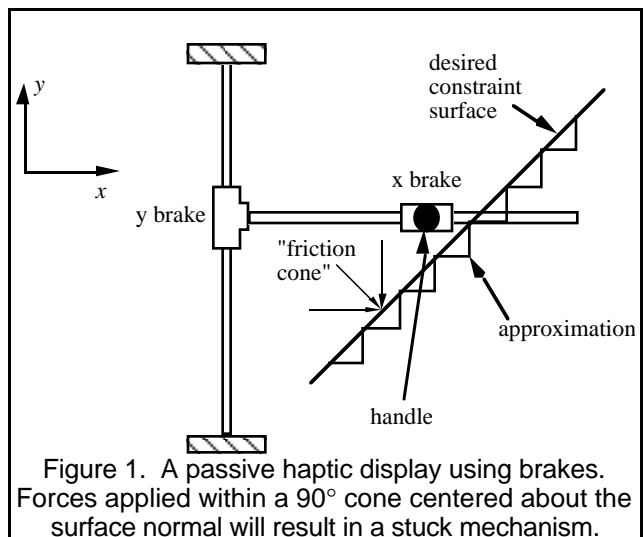

One way around this tradeoff is to use controllable brakes rather than (or in addition to) servoed actuators at the joints of the robot [6]. Brakes can implement very hard constraints and are completely passive. Brakes, however, suffer from one very serious drawback, illustrated with a simple example in Figure 1. In this example, a two-axis Cartesian haptic display is contemplated. It should be quite evident that, by braking the x-axis, a wall in the y-direction can be implemented. This is, of course, not without subtlety. For instance, walls are usually unilateral, and therefore force sensing is needed to determine when the display is being pulled away from the wall, so that the brake can be turned off. There is, however, a much more serious difficulty. Suppose that one

wishes to implement a wall at a 45° angle, as illustrated. The only way to achieve this is to approximate the 45° smooth wall with a series of steps. The user is certain to perceive these steps. Moreover, this wall exhibits a behavior not unlike friction: any force in a 90° cone angle centered about the wall's outward normal will result in both brakes being activated, and the mechanism becoming stuck.

Delnondedieu and Troccaz [2] describe an energetically passive manipulator named “PADyC” which uses overrunning clutches rather than brakes. At each joint are two such clutches, each of which runs on a motor-driven drum. One drum rotates clockwise and the other counterclockwise. The rotational speeds of these drums determine the maximum clockwise and counterclockwise joint angular velocities which an operator can generate without engaging a clutch. Thus, an operator is effectively speed-limited in the joint space. As in the example discussed above, however, limited directions of constraint are available so that achieving a smooth feel is an inherently difficult problem.

In this paper, we introduce a new approach to implementing programmable constraint which produces smooth, hard, passive constraints. The basic idea is diametrically opposed to the conventional approach: we begin with a mechanism that has either zero or one d.o.f., and use feedback control to make it behave as though it has additional d.o.f., as necessary to be consistent with the programmed constraint. The key to implementing this strategy is the use of nonholonomic joints.

In the next section, the concept of a nonholonomic haptic display (or “programmable constraint machine”, PCM) is illustrated via two simple examples. In Section 3, an approach to increasing the apparent d.o.f. of such a device is discussed, and in Section 4, some basic considerations for implementing constraints are discussed. Section 5 describes a prototype PCM and presents experimental results, and Section 6 offers concluding remarks and a discussion of future research directions.

2. Unicycle and Bicycle PCMs

Consider a very simple system involving constraint, consisting of a particle and a surface, as illustrated in Figure 2. In this system, an operator pushes a particle (black circle) in the plane. Free motion is permitted in region A, but the particle cannot penetrate the curved wall of the physical constraint, region B. The operator may, however, push the particle along the constraint. We will now describe the “unicycle PCM”, which is a nonholonomic haptic display designed to emulate the behavior of such a system.

The unicycle PCM consists of a single steerable wheel that rolls on the plane (a horizontal surface). A human operator grabs onto and pushes the shaft of the unicycle, as in Figure 3. (In this simple example one must imagine that the operator’s hand can perform only planar motions, so that the unicycle is always strictly

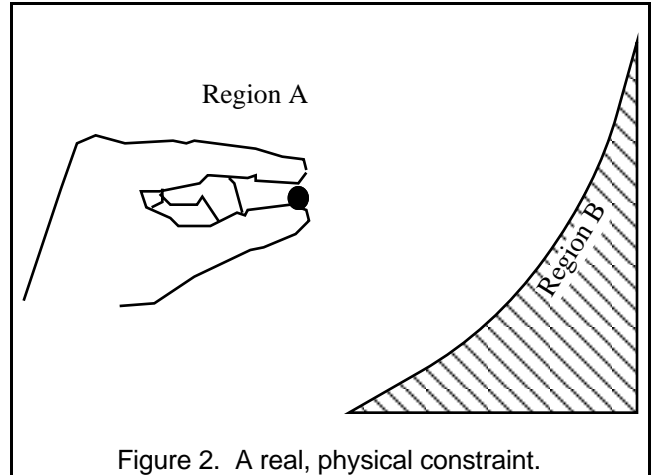

Figure 2. A real, physical constraint.

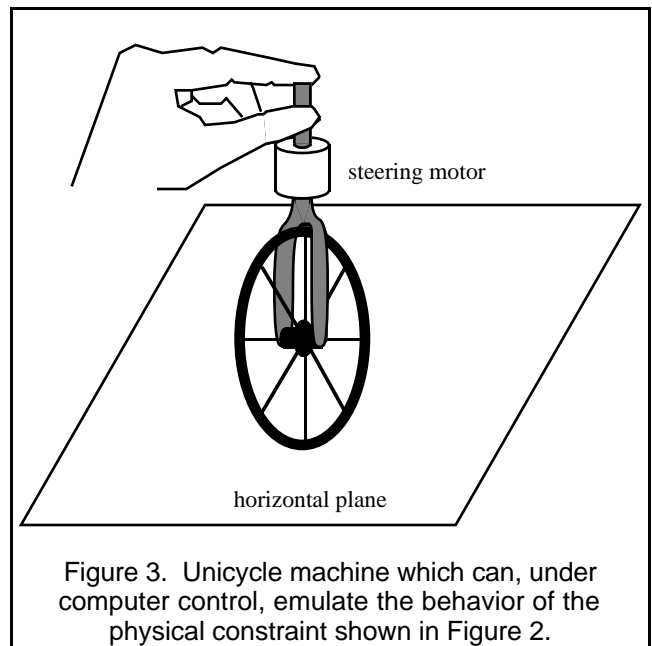

Figure 3. Unicycle machine which can, under computer control, emulate the behavior of the physical constraint shown in Figure 2.

upright.) There are two modes of operation:

1. (“Virtual Caster”) In free space (Region A), the wheel acts like a caster so that it doesn’t constrain motion at all. The wheel is not a caster in the conventional sense. Instead, it has a straight-up shaft like a unicycle, but this shaft is instrumented with a force sensor. If the sensor detects forces perpendicular to the wheel’s rolling direction, the wheel is steered (by a motor) to minimize these forces. In effect, the wheel turns so that it can roll in the direction it is pushed, and so, from the user’s point of view, it is like a free particle which he or she can move around the plane at will.
2. (“Virtual Wall”) When the user moves the shaft to the edge of the free region (to the interface of regions A

and B), the computer which controls the steering motor no longer does so in such a way as to minimize force. Instead, the steering motor is used to turn the wheel so that its rolling direction is tangential to the constraint. The force sensor mentioned above still monitors forces perpendicular to the wheel. If the forces would tend to push the wheel into the constraint, they are ignored. If the forces would tend to pull the wheel off of the constraint, they are interpreted just as in the free space mode. This means that it is impossible to push the unicycle past a virtual constraint (unless the wheel slips), but that the unicycle can easily be pulled off of the constraint surface.

This machine has some interesting and desirable characteristics. First, although it is a one d.o.f. device (the wheel fixes the ratio of x and y velocities), in the virtual caster mode, it behaves as though it has two d.o.f. Second, although it uses a motor to steer, it is completely passive in the plane of operation¹. Because the motor exerts torques about an axis that passes through the wheel/ground contact point, it does not generate any reaction forces in the plane. It is important to note that motorized steering of a conventional offset caster would not be passive: this is the reason that we have chosen to design a virtual caster.

For the virtual caster and virtual wall behaviors to succeed, the steering control system must be carefully conceived. For instance, for virtual caster operation, it is important that the control system be able to keep lateral forces on the wheel nulled regardless of operator behavior. This problem will be discussed further in the next section. For virtual wall operation, it is important that the absolute location and orientation of the wheel be known at all times. It is possible to achieve this by starting motion in a known location, measuring wheel speed and direction, and integrating. This approach, however, is not robust to wheel slip. A simpler, more robust approach, is to attach the wheel to a planar kinematic mechanism which is outfitted with position sensors. This mechanism will have a limited workspace, which is not a problem for most applications. A simple mechanism would be an xy frame, as shown in Figure 4. The frame can also serve to absorb reaction forces generated by the steering motor.

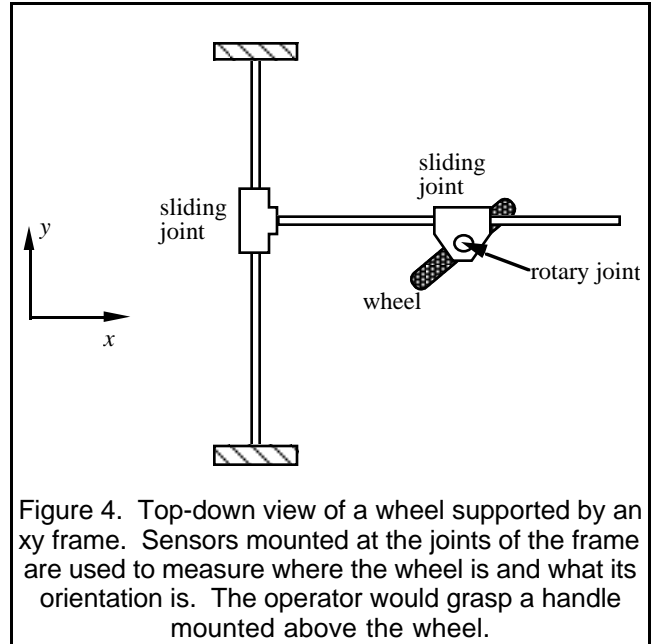

Figure 4. Top-down view of a wheel supported by an xy frame. Sensors mounted at the joints of the frame are used to measure where the wheel is and what its orientation is. The operator would grasp a handle mounted above the wheel.

A unicycle PCM can constrain motion in x and y , but it cannot constrain orientation. In many applications (e.g., robot-assisted surgery) orientation is very important. A “bicycle PCM”, shown in Figure 5, can implement x , y , and angular constraint. This machine consists of two independently steerable wheels whose shafts are held a fixed distance from one another. Both are controlled in a manner comparable to that described for the unicycle PCM.

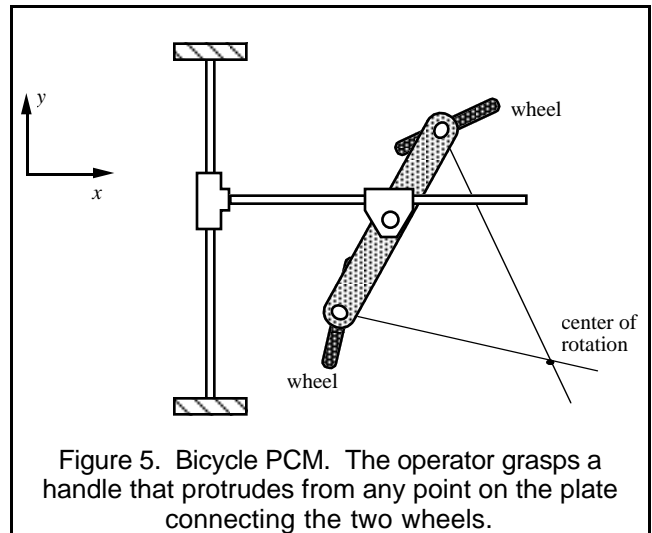

Figure 5. Bicycle PCM. The operator grasps a handle that protrudes from any point on the plate connecting the two wheels.

¹ For the realization shown in Figure 3, the motor will exert a reaction torque on the operator’s hand, but this problem is easily addressed (see, for instance, Figure 4).

With this example we can begin to see that, like other robotic mechanisms, nonholonomic constraint machines exhibit singularities. Any motion of the bicycle machine can be viewed as a rotation about the instantaneous center of rotation (see Figure 5). It is not possible, however, to specify a center of rotation on the line that

passes through the two wheel shafts. If we attempt to do so, the two wheels will both be aimed perpendicular to this line. In this configuration, the machine actually gains a degree of freedom, going from one to two (of course, we usually think of singularities as reducing the d.o.f.).

One way to solve this problem is to add a third wheel whose shaft is not collinear with the other two. This would also have the benefit of making the machine statically stable, eliminating the need for a frame. The design of higher d.o.f. constraint machines is discussed in [4].

3. The Virtual Caster

Proper operation of the virtual caster is obviously the key to the concept we have described: without it, we cannot *add* degrees of freedom to a nonholonomically constrained device. In this section, we discuss virtual caster control for the unicycle machine.

The ideal caster controller would perceptually eliminate the wheel. In other words, a user manipulating the machine would perceive it to be a single rigid body. In the case of a unicycle machine, it is useful to think of that body as a point mass. For a point mass, the acceleration and force vectors are collinear and in fixed proportion. The implication for a unicycle is that, not only must forces in the wheel direction, F_{\parallel} , produce accelerations of $a_{\parallel} = F_{\parallel}/M$, but forces normal to the wheel, F_{\perp} , must similarly produce accelerations of $a_{\perp} = F_{\perp}/M$. A very simple kinematic analysis, however, shows that a wheel traveling at a speed u with a steering velocity ω , has an instantaneous normal acceleration of $a_{\perp} = u\omega$. Thus, we can obtain a prescription for the steering velocity which would result in particle-like behavior:

$$\omega = \frac{F_{\perp}}{uM} \quad (1)$$

Equation 1 is extremely useful. From it we learn that the problem of virtual caster control is fundamentally nonlinear: the correct sign of the steering velocity is determined by the product of the signs

of F_{\perp} and u , which cannot be approximated by a linear relation. We also learn that, for a given normal force, the steering velocity scales inversely with the translational velocity. Because of this, there is a singularity at zero speed. At zero speed, it is not physically possible to make the unicycle behave like a particle.

4. Virtual Wall

Implementing a hard virtual wall using a conventional haptic display is a difficult problem [1], while implementing a virtual wall using a nonholonomic haptic display is not very difficult at all. The basic idea is to define a surface² $C(q)$ in the configuration space (q) of the machine such that, for $C(q) > 0$, the machine is outside the wall. Then, it is necessary only to steer the machine along the wall whenever $C(q) \leq 0$ and F_{\perp} points into the wall, and to return to caster mode when F_{\perp} points away from the wall.

Although the basic idea is simple, one rather obvious difficulty has to do with impact. Consider again the unicycle constraint machine. In the extreme case of a high speed impact along a normal direction, the wheel will need to execute a 90° turn upon contact. In the course of turning, the operator's hand will surely be deflected to the side. There is also an issue of whether or not to predict impact with the wall and begin turning the wheel prior to impact. We have not yet addressed either of these questions in a formal manner, preferring instead to gain practical experience with a unicycle PCM.

5. Prototype PCM and Experiments

A prototype unicycle machine, of the sort portrayed in Figure 3, has been built (Figure 5), and both virtual caster and virtual wall controllers have been implemented.

The unicycle is supported upright by an xy frame which is instrumented

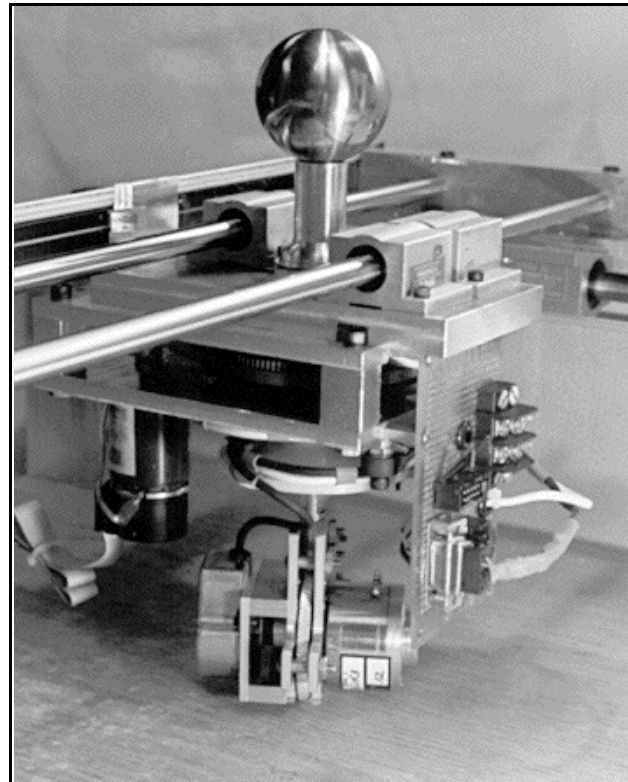

Figure 5. Photograph of the unicycle machine prototype. Components that can be seen include the handle; the xy frame, instrumented with linear potentiometers; the steering motor and transmission; and the wheel assembly including a high resolution encoder and a particle brake (not in use, currently).

²The surface could as well be defined parametrically.

for position. The unicycle assembly includes a dc motor for steering; an optical encoder that measures steering angle; another optical encoder that measures wheel rotation (this is used to derive translational velocity, u); and a strain gage bridge that measures normal force, F_{\perp} . Also included, though not pictured in Figure 5, is a handle-mounted sensor that measures x and y components of the user-applied force. Feedback control is implemented on a Pentium computer, at a controller update rate of 1 kHz.

The caster controller follows the form of Equation 1, but is modified for torque control and finite sensor resolution. Because the steering motor is torque controlled, an “inner” loop is first closed around steering velocity, ω . Due to the high update rate, however, this controller and the “outer” steering angle controller are in fact implemented together.

Due to finite sensor resolution and the singularity at zero translational velocity, the denominator of Equation 1 must also be modified to prevent overflow, excessively large control signals, and instability. The form of the virtual caster controller which has been implemented is:

$$\tau = \frac{K_1 F_{\perp}}{u + \varepsilon \operatorname{sign}(u)} - K_2 \omega \quad (2)$$

K_1 is an adjustable gain which replaces $1/M$ in Equation 1, and K_2 is a gain associated with the steering velocity controller. ε is an adjustable parameter which places a lower limit on the denominator magnitude (ε is of the same order as the velocity resolution). These gains are adjusted for performance and stability. u and ω are estimated by digital differentiation and digital filtering of the associated angular measures.

Two methods of measuring F_{\perp} have been implemented. The first method employs a strain gage bridge mounted on the vertical steering shaft. Because the bridge is in the frame of the rotating wheel, it provides a simple, straightforward way of measuring normal force. Unfortunately, this doesn’t turn out to be a very useful measure, because the force acting on the wheel has contributions from both the operator’s hand and the frictional resistance in the xy frame. We wish to respond to the former and ignore the latter, which is not possible with the shaft-mounted sensor. The second approach, therefore, uses a two-axis force sensor mounted just below the handle to measure only the operator-applied force. This measure, along with a measure of steering angle, permits a “clean” estimate of F_{\perp} , which proves much more useful in practice.

The initial implementation of a virtual wall is extremely simple. When it is determined that the position of the handle is inside the wall, caster control is replaced by a steering angle controller which aligns the wheel tangent to the wall. This controller is essentially a steering angle servo; however, if a normal force is measured which points out of the wall, caster control is reinstated. It should be noted that this controller does allow wall penetration which is velocity-dependent. Because the steering angle controller is fairly responsive, this has not proved to be serious problem.

Figure 6 displays a set of experimental data. The PCM trajectory (curved line) and, at selected points, the operator-applied force, are shown for both virtual caster and virtual wall operation. During virtual caster operation, the force remains small except during low-speed direction changes (apparent as kinks and cusps in the trajectory). Upon striking the wall at $x = 4$, it is apparent that the wheel aligns very rapidly with the tangent (in this case, the vertical), and that penetrating forces are ignored. When, however, the force points away from the wall, the wheel begins to turn in that direction. Users have described the virtual caster as “better than a real caster”, and have also found the virtual wall to be quite compelling.

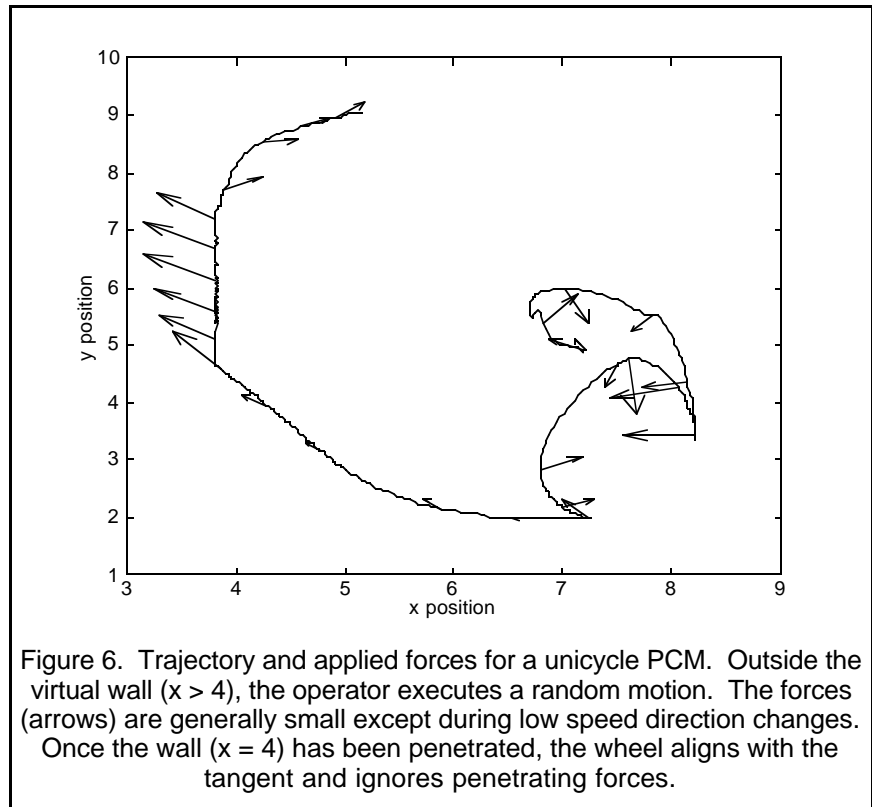

Figure 6. Trajectory and applied forces for a unicycle PCM. Outside the virtual wall ($x > 4$), the operator executes a random motion. The forces (arrows) are generally small except during low speed direction changes. Once the wall ($x = 4$) has been penetrated, the wheel aligns with the tangent and ignores penetrating forces.

5. Conclusions and Future Directions

A novel approach to the haptic display of virtual constraints has been presented. The key idea is the use of nonholonomic joints to implement constraints which are

completely passive from the operator's perspective, and which are also perceptually smooth along any direction in the configuration space. The feasibility of this concept has been demonstrated with a prototype unicycle machine.

The future of our research includes both application and generalization to higher degrees of freedom. In particular, we are studying applications in the general area of automobile assembly; we are developing a three-wheel planar PCM, and we are investigating the problem of implementing constraints in higher degrees-of-freedom.

Several devices with even greater numbers of generalized coordinates have been described in a companion paper [4]. Also in this paper, an important new building block of constraint machines, a four-quadrant continuously variable transmission, is introduced.

Acknowledgements

This work has been supported by a grant from the GM Foundation. We are particularly grateful for the support of Prasad Akella, Nick Caruso and Steve Holland. In addition, we thank Y.C. Chiou and C.H. Lee for their assistance in fabrication of the prototype.

References

- [1] Colgate, J. E. and J. M. Brown. *Factors Affecting the Z-width of a Haptic Display*. International Conference on Robotics and Automation. San Diego, CA. pp. 3205-10, IEEE R&A Society, 1994.
- [2] Delnondedieu, Y. and J. Troccaz. *PADyC: a Passive Arm with Dynamic Constraints; a prototype with two degrees of freedom*. Medical Robotics and Computer Assisted Surgery. Baltimore, Maryland. pp. 173-180, IEEE, 1995.
- [3] Kelley, A. J. and S. E. Salcudean. *On the Development of a Force-Feedback Mouse and Its Integration Into a Graphical User Interface*. International Mechanical Engineering Congress and Exposition. Chicago. pp. 287-294, ASME, 1994.
- [4] Peshkin, M., J. E. Colgate and C. Moore. *Constraint Machines Based on Continuously Variable Transmissions, for Haptic Interaction with People*. IEEE International Conference on Robotics and Automation. 1996.
- [5] Rosenberg, L. B. *Virtual Fixtures: Perceptual overlays enhance operator performance in telepresence tasks*. Ph.D. dissertation, Stanford Univ., Dept. of Mechanical Engineering, 1994.
- [6] Russo, M. and A. Tadros. *Controlling Dissipative Magnetic Particle Brakes in Force Reflective Devices*. ASME Winter Annual Meeting. Anaheim, California. pp. 63-70, 1992.