

# Over-The-Top Micropower Rail-to-Rail Input and Output Op Amp

## FEATURES

- Rail-to-Rail Input and Output
- Micropower: 50µA I<sub>Q</sub>, 44V Supply
- MSOP Package
- Over-The-Top™: Input Common Mode Range Extends 44V Above V<sub>EE</sub>, Independent of V<sub>CC</sub>
- Low Input Offset Voltage: 225µV Max
- Specified on 3V, 5V and ±15V Supplies
- High Output Current: 18mA
- Output Shutdown
- Output Drives 10,000pF with Output Compensation
- Reverse Battery Protection to 27V
- High Voltage Gain: 2000V/mV
- High CMRR: 110dB
- 220kHz Gain-Bandwidth Product

## APPLICATIONS

- Battery- or Solar-Powered Systems
  - Portable Instrumentation
  - Sensor Conditioning
- Supply Current Sensing
- Battery Monitoring
- MUX Amplifiers
- 4mA to 20mA Transmitters

## DESCRIPTION

The LT<sup>®</sup>1636 op amp operates on all single and split supplies with a total voltage of 2.7V to 44V drawing less than 50µA of quiescent current. The LT1636 can be shut down, making the output high impedance and reducing the quiescent current to 4µA. The LT1636 has a unique input stage that operates and remains high impedance when above the positive supply. The inputs take 44V both differential and common mode, even when operating on a 3V supply. The output swings to both supplies. Unlike most micropower op amps, the LT1636 can drive heavy loads; its rail-to-rail output drives 18mA. The LT1636 is unity-gain stable into all capacitive loads up to 10,000pF when a 0.22µF and 150Ω compensation network is used.

The LT1636 is reverse supply protected: it draws no current for reverse supply up to 27V. Built-in resistors protect the inputs for faults below the negative supply up to 22V. There is no phase reversal of the output for inputs 5V below V<sub>EE</sub> or 44V above V<sub>EE</sub>, independent of V<sub>CC</sub>.

The LT1636 op amp is available in the 8-pin MSOP, PDIP and SO packages.

LT, LTC and LT are registered trademarks of Linear Technology Corporation. Over-The-Top is a trademark of Linear Technology Corporation.

## TYPICAL APPLICATION

Over-The-Top Current Source with Shutdown

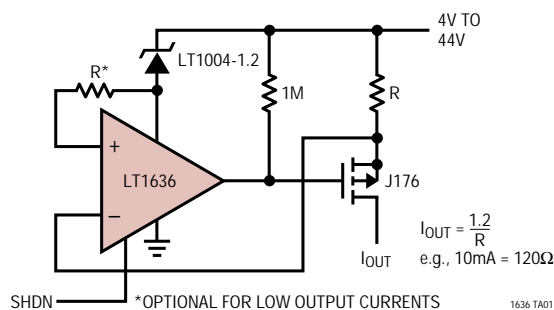

Input Bias Current vs Common Mode Voltage

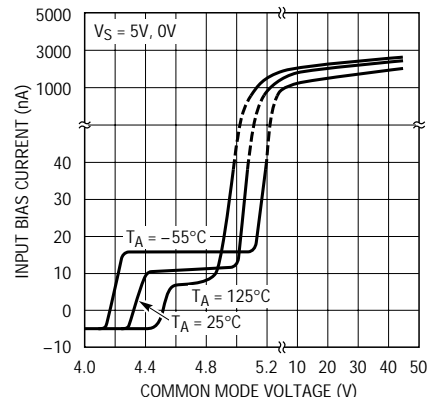

## ABSOLUTE MAXIMUM RATINGS (Note 1)

Total Supply Voltage ( $V^+$ to $V^-$ ) .....	44V	Operating Temperature Range .....	-40°C to 85°C
Input Differential Voltage .....	44V	Specified Temperature Range (Note 3) ..	-40°C to 85°C
Input Current .....	±25mA	Junction Temperature .....	150°C
Shutdown Pin Voltage Above $V^-$ .....	32V	Storage Temperature Range .....	-65°C to 150°C
Shutdown Pin Current .....	±10mA	Lead Temperature (Soldering, 10 sec) .....	300°C
Output Short-Circuit Duration (Note 2) .....	Continuous		

## PACKAGE/ORDER INFORMATION

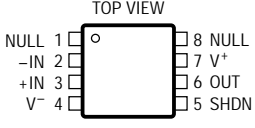
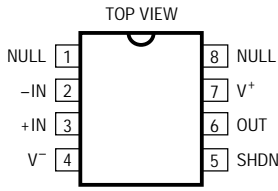
 <p>MS8 PACKAGE 8-LEAD PLASTIC MSOP <math>T_{JMAX} = 150^{\circ}C, \theta_{JA} = 250^{\circ}C/W</math></p>	ORDER PART NUMBER	 <p>N8 PACKAGE 8-LEAD PLASTIC DIP S8 PACKAGE 8-LEAD PLASTIC SO <math>T_{JMAX} = 150^{\circ}C, \theta_{JA} = 130^{\circ}C/W</math> (N8) <math>T_{JMAX} = 150^{\circ}C, \theta_{JA} = 190^{\circ}C/W</math> (S8)</p>	ORDER PART NUMBER
	LT1636CMS8		LT1636CN8 LT1636CS8 LT1636IN8 LT1636IS8
	MS8 PART MARKING		S8 PART MARKING
	LTCL		1636 1636I

Consult factory for Military grade parts.

## 3V, 5V ELECTRICAL CHARACTERISTICS

$V_S = 3V, 0V; V_S = 5V, 0V; V_{CM} = V_{OUT} =$  half supply, Pin 5 = open or  $V_{EE}$ , Pins 1 and 8 open,  $T_A = 25^{\circ}C$  unless otherwise noted. (Note 3)

SYMBOL	PARAMETER	CONDITIONS	MIN	TYP	MAX	UNITS
$V_{OS}$	Input Offset Voltage	N8 Package $0^{\circ}C \leq T_A \leq 70^{\circ}C$ $-40^{\circ}C \leq T_A \leq 85^{\circ}C$	●	50	225	$\mu V$
			●		400	$\mu V$
			●		550	$\mu V$
	Input Offset Voltage Drift (Note 8)	S8 Package $0^{\circ}C \leq T_A \leq 70^{\circ}C$ $-40^{\circ}C \leq T_A \leq 85^{\circ}C$	●	50	225	$\mu V/^{\circ}C$
			●		600	$\mu V/^{\circ}C$
			●		750	$\mu V/^{\circ}C$
	Input Offset Voltage Drift (Note 8)	MS8 Package $0^{\circ}C \leq T_A \leq 70^{\circ}C$ $-40^{\circ}C \leq T_A \leq 85^{\circ}C$	●	50	225	$\mu V/^{\circ}C$
			●		700	$\mu V/^{\circ}C$
			●		850	$\mu V/^{\circ}C$
$I_{OS}$	Input Offset Current	N8 Package, $-40^{\circ}C \leq T_A \leq 85^{\circ}C$	●	1	5	$\mu V/^{\circ}C$
		S8 Package, $-40^{\circ}C \leq T_A \leq 85^{\circ}C$	●	2	8	$\mu V/^{\circ}C$
$I_B$	Input Bias Current	MS8 Package, $-40^{\circ}C \leq T_A \leq 85^{\circ}C$	●	2	10	$\mu V/^{\circ}C$
			●			
$I_{OS}$	Input Offset Current	$V_{CM} = 44V$ (Note 4)	●	0.1	0.8	nA
			●		0.6	$\mu A$
$I_B$	Input Bias Current	$V_{CM} = 44V$ (Note 4)	●	5	8	nA
		$V_S = 0V$	●	3	6	$\mu A$
	Input Noise Voltage	0.1Hz to 10Hz		0.7		$\mu V_{P-P}$
$e_n$	Input Noise Voltage Density	f = 1kHz		52		nV/ $\sqrt{Hz}$
$i_n$	Input Noise Current Density	f = 1kHz		0.035		pA/ $\sqrt{Hz}$

### 3V, 5V ELECTRICAL CHARACTERISTICS

$V_S = 3V, 0V; V_S = 5V, 0V; V_{CM} = V_{OUT} = \text{half supply, Pin 5} = \text{open or } V_{EE}, \text{ Pins 1 and 8 open, } T_A = 25^\circ\text{C unless otherwise noted. (Note 3)}$

SYMBOL	PARAMETER	CONDITIONS	MIN	TYP	MAX	UNITS
$R_{IN}$	Input Resistance	Differential	6	10		$M\Omega$
		Common Mode, $V_{CM} = 0V \text{ to } 44V$	7	15		$M\Omega$
$C_{IN}$	Input Capacitance			4		pF
	Input Voltage Range		● 0		44	V
CMRR	Common Mode Rejection Ratio (Note 4)	$V_{CM} = 0V \text{ to } V_{CC} - 1V$	● 84	110		dB
		$V_{CM} = 0V \text{ to } 44V \text{ (Note 7)}$	● 86	98		dB
$A_{VOL}$	Large-Signal Voltage Gain	$V_S = 3V, V_O = 500mV \text{ to } 2.5V, R_L = 10k$	● 200	1300		V/mV
		$V_S = 3V, 0^\circ\text{C} \leq T_A \leq 70^\circ\text{C}$	● 133			V/mV
		$V_S = 3V, -40^\circ\text{C} \leq T_A \leq 85^\circ\text{C}$	● 100			V/mV
		$V_S = 5V, V_O = 500mV \text{ to } 4.5V, R_L = 10k$	● 400	2000		V/mV
		$V_S = 5V, 0^\circ\text{C} \leq T_A \leq 70^\circ\text{C}$	● 250			V/mV
		$V_S = 5V, -40^\circ\text{C} \leq T_A \leq 85^\circ\text{C}$	● 200			V/mV
$V_{OL}$	Output Voltage Swing LOW	No Load	●		10	mV
		$I_{SINK} = 5mA$	●	480	875	mV
		$V_S = 5V, I_{SINK} = 10mA$	●	860	1600	mV
$V_{OH}$	Output Voltage Swing HIGH	$V_S = 3V, \text{No Load}$	● 2.95	2.985		V
		$V_S = 3V, I_{SOURCE} = 5mA$	● 2.55	2.8		V
		$V_S = 5V, \text{No Load}$	● 4.95	4.985		V
		$V_S = 5V, I_{SOURCE} = 10mA$	● 4.30	4.75		V
$I_{SC}$	Short-Circuit Current (Note 2)	$V_S = 3V, \text{Short to GND}$		7	15	mA
		$V_S = 3V, \text{Short to } V_{CC}$		20	42	mA
		$V_S = 5V, \text{Short to GND}$		12	25	mA
		$V_S = 5V, \text{Short to } V_{CC}$		25	50	mA
PSRR	Power Supply Rejection Ratio	$V_S = 2.7V \text{ to } 12.5V, V_{CM} = V_O = 1V$	● 90	103		dB
	Reverse Supply Voltage	$I_S = -100\mu A$	● 27	40		V
$I_S$	Supply Current (Note 5)		●	42	55	$\mu A$
					60	$\mu A$
		Supply Current, SHDN	$V_{PIN5} = 2V, \text{No Load (Note 5)}$	●	4	12
$I_{SD}$	Shutdown Pin Current	$V_{PIN5} = 0.3V, \text{No Load (Note 5)}$	●	0.5	15	nA
		$V_{PIN5} = 2V, \text{No Load (Note 4)}$	●	1.1	5	$\mu A$
	Output Leakage Current	$V_{PIN5} = 2V, \text{No Load (Note 5)}$	●	0.05	1	$\mu A$
	Maximum Shutdown Pin Current	$V_{PIN5} = 32V, \text{No Load (Note 4)}$	●	27	150	$\mu A$
$t_{ON}$	Turn-On Time	$V_{PIN5} = 5V \text{ to } 0V, R_L = 10k$		120		$\mu s$
$t_{OFF}$	Turn-Off Time	$V_{PIN5} = 0V \text{ to } 5V, R_L = 10k$		2.5		$\mu s$
GBW	Gain Bandwidth Product (Note 4)	$f = 1kHz$	● 110	200		kHz
		$0^\circ\text{C} \leq T_A \leq 70^\circ\text{C}$	● 100			kHz
		$-40^\circ\text{C} \leq T_A \leq 85^\circ\text{C}$	● 90			kHz
SR	Slew Rate (Note 6)	$A_V = -1, R_L = \infty$	● 0.035	0.07		V/ $\mu s$
		$0^\circ\text{C} \leq T_A \leq 70^\circ\text{C}$	● 0.031			V/ $\mu s$
		$-40^\circ\text{C} \leq T_A \leq 85^\circ\text{C}$	● 0.030			V/ $\mu s$

## ±15V ELECTRICAL CHARACTERISTICS

$V_S = \pm 15V$ ,  $V_{CM} = 0V$ ,  $V_{OUT} = 0V$ , Pin 5 = open or  $V_{EE}$ , Pins 1 and 8 open,  $T_A = 25^\circ C$  unless otherwise noted. (Note 3)

SYMBOL	PARAMETER	CONDITIONS	MIN	TYP	MAX	UNITS
$V_{OS}$	Input Offset Voltage	N8 Package $0^\circ C \leq T_A \leq 70^\circ C$ $-40^\circ C \leq T_A \leq 85^\circ C$	●	100	450	$\mu V$
			●		550	$\mu V$
			●		700	$\mu V$
		S8 Package $0^\circ C \leq T_A \leq 70^\circ C$ $-40^\circ C \leq T_A \leq 85^\circ C$	●	100	450	$\mu V$
			●		750	$\mu V$
			●		900	$\mu V$
		MS8 Package $0^\circ C \leq T_A \leq 70^\circ C$ $-40^\circ C \leq T_A \leq 85^\circ C$	●	100	450	$\mu V$
			●		850	$\mu V$
			●		1000	$\mu V$
	Input Offset Voltage Drift (Note 8)	N8 Package, $-40^\circ C \leq T_A \leq 85^\circ C$ S8 Package, $-40^\circ C \leq T_A \leq 85^\circ C$ MS8 Package, $-40^\circ C \leq T_A \leq 85^\circ C$	● ● ●	1 2 2	4 8 10	$\mu V/^\circ C$ $\mu V/^\circ C$ $\mu V/^\circ C$
$I_{OS}$	Input Offset Current		●	0.2	1.0	nA
$I_B$	Input Bias Current		●	4	10	nA
	Input Noise Voltage	0.1Hz to 10Hz		1		$\mu V_{P-P}$
$e_n$	Input Noise Voltage Density	$f = 1kHz$		52		$nV/\sqrt{Hz}$
$i_n$	Input Noise Current Density	$f = 1kHz$		0.035		$pA/\sqrt{Hz}$
$R_{IN}$	Input Resistance	Differential		5.2	13	$M\Omega$
		Common Mode, $V_{CM} = -15V$ to $14V$			12000	$M\Omega$
$C_{IN}$	Input Capacitance			4		pF
	Input Voltage Range		●	-15	29	V
CMRR	Common Mode Rejection Ratio	$V_{CM} = -15V$ to $29V$	●	86	103	dB
$A_{VOL}$	Large-Signal Voltage Gain	$V_O = \pm 14V$ , $R_L = 10k$ $0^\circ C \leq T_A \leq 70^\circ C$ $-40^\circ C \leq T_A \leq 85^\circ C$	● ● ●	100 75 50	500	$V/mV$ $V/mV$ $V/mV$
			●			
			●			
$V_{OL}$	Output Voltage Swing LOW	No Load	●	-14.997	-14.95	V
		$I_{SINK} = 5mA$	●	-14.500	-14.07	V
		$I_{SINK} = 10mA$	●	-14.125	-13.35	V
$V_{OH}$	Output Voltage Swing HIGH	No Load	●	14.9	14.975	V
		$I_{SOURCE} = 5mA$	●	14.5	14.750	V
		$I_{SOURCE} = 10mA$	●	14.3	14.650	V
$I_{SC}$	Short-Circuit Current (Note 2)	Short to GND $0^\circ C \leq T_A \leq 70^\circ C$ $-40^\circ C \leq T_A \leq 85^\circ C$	● ● ●	$\pm 18$ $\pm 15$ $\pm 10$	$\pm 30$	mA mA mA
			●			
			●			
PSRR	Power Supply Rejection Ratio	$V_S = \pm 1.35V$ to $\pm 22V$	●	90	114	dB
$I_S$	Supply Current		●	50	70	$\mu A$
			●		85	$\mu A$
	Positive Supply Current, SHDN	$V_{PIN5} = -20V$ , $V_S = \pm 22V$ , No Load	●	12	30	$\mu A$
$I_{SHDN}$	Shutdown Pin Current	$V_{PIN5} = -21.7V$ , $V_S = \pm 22V$ , No Load	●	0.7	15	nA
		$V_{PIN5} = -20V$ , $V_S = \pm 22V$ , No Load	●	1.2	8	$\mu A$
	Maximum Shutdown Pin Current	$V_{PIN5} = 32V$ , $V_S = \pm 22V$	●	27	150	$\mu A$
	Output Leakage Current	$V_{PIN5} = -20V$ , $V_S = \pm 22V$ , No Load	●	0.1	2	$\mu A$
GBW	Gain Bandwidth Product	$f = 1kHz$ $0^\circ C \leq T_A \leq 70^\circ C$ $-40^\circ C \leq T_A \leq 85^\circ C$	● ● ●	125 110 100	220	kHz kHz kHz
			●			
			●			

## ±15V ELECTRICAL CHARACTERISTICS

$V_S = \pm 15V$ ,  $V_{CM} = 0V$ ,  $V_{OUT} = 0V$ , Pin 5 = open or  $V_{EE}$ , Pins 1 and 8 open,  $T_A = 25^\circ C$  unless otherwise noted. (Note 3)

SYMBOL	PARAMETER	CONDITIONS	MIN	TYP	MAX	UNITS	
SR	Slew Rate	$A_V = -1$ , $R_L = \infty$ , $V_O = \pm 10V$ Measured at $\pm 5V$		0.0375	0.075		V/ $\mu s$
		$0^\circ C \leq T_A \leq 70^\circ C$	●	0.033			V/ $\mu s$
		$-40^\circ C \leq T_A \leq 85^\circ C$	●	0.030			V/ $\mu s$

The ● denotes specifications that apply over the full specified temperature range.

**Note 1:** Absolute Maximum Ratings are those values beyond which the life of a device may be impaired.

**Note 2:** A heat sink may be required to keep the junction temperature below absolute maximum.

**Note 3:** The LT1636C is guaranteed to meet specified performance from  $0^\circ C$  to  $70^\circ C$  and is designed, characterized and expected to meet these extended temperature limits, but is not tested at  $-40^\circ C$  and  $85^\circ C$ . The LT1636I is guaranteed to meet the extended temperature limits.

**Note 4:**  $V_S = 5V$  limits are guaranteed by correlation to  $V_S = 3V$ , and  $V_S = \pm 15V$  or  $V_S = \pm 22V$  tests.

**Note 5:**  $V_S = 3V$  limits are guaranteed by correlation to  $V_S = 5V$ , and  $V_S = \pm 15V$  or  $V_S = \pm 22V$  tests.

**Note 6:** Guaranteed by correlation to slew rate at  $V_S = \pm 15V$ , and GBW at  $V_S = 3V$  and  $V_S = \pm 15V$  tests.

**Note 7:** This specification implies a typical input offset voltage of  $600\mu V$  at  $V_{CM} = 44V$  and a maximum input offset voltage of  $3mV$  at  $V_{CM} = 44V$ .

**Note 8:** This parameter is not 100% tested.

## TYPICAL PERFORMANCE CHARACTERISTICS

Supply Current vs Supply Voltage

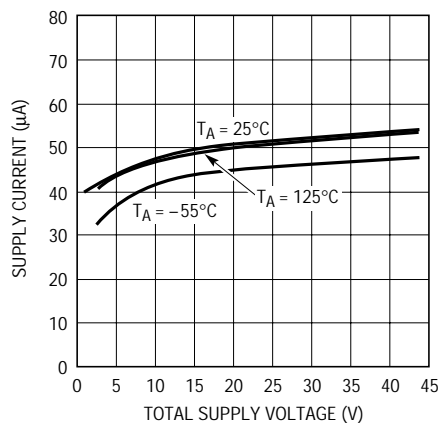

1636 G01

Minimum Supply Voltage

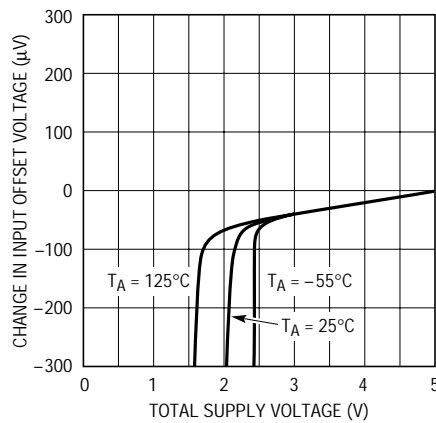

1636 G02

Input Bias Current vs Common Mode Voltage

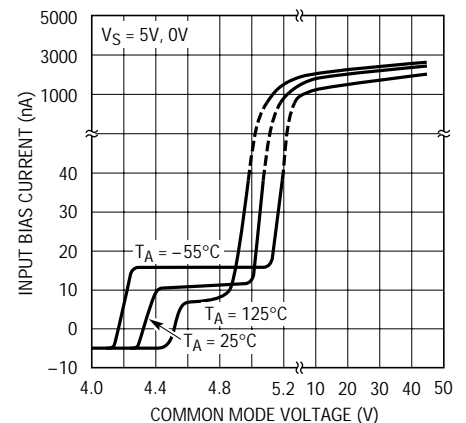

1636 G03

Output Saturation Voltage vs Load Current (Output High)

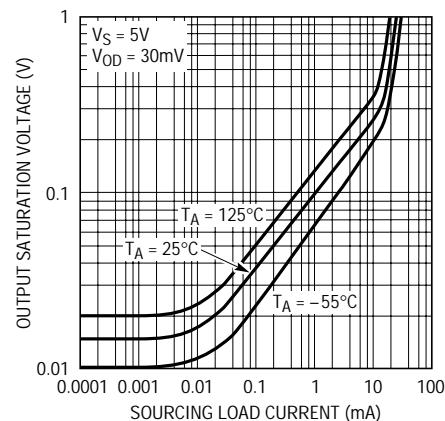

1636 G04

Output Saturation Voltage vs Load Current (Output Low)

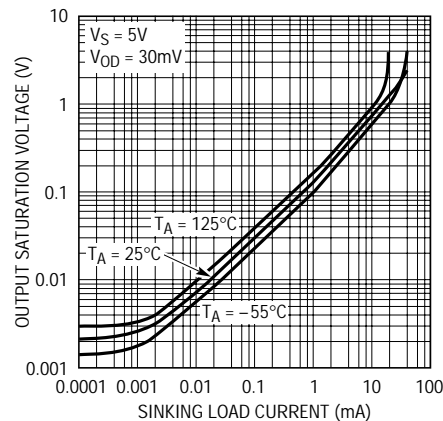

1636 G05

Output Saturation Voltage vs Input Overdrive

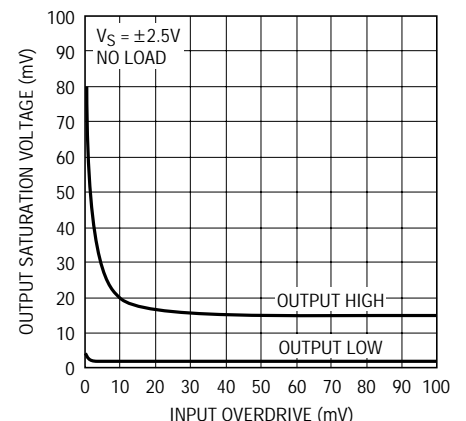

1636 G06

# TYPICAL PERFORMANCE CHARACTERISTICS

0.1Hz to 10Hz Noise Voltage

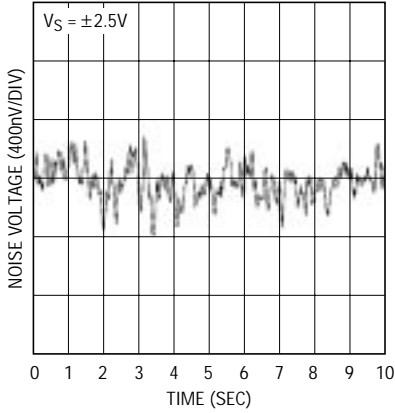

1636 G07

Noise Voltage Density vs Frequency

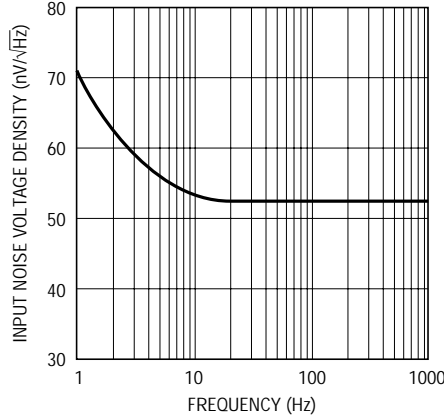

1636 G08

Input Noise Current vs Frequency

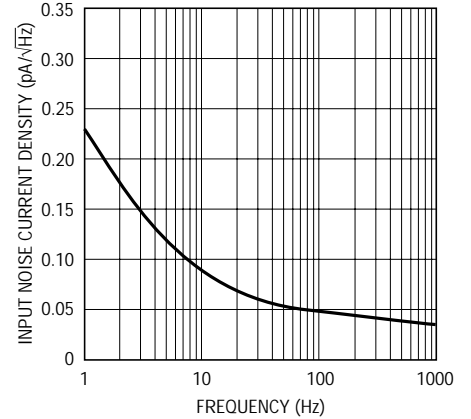

1636 G09

Open-Loop Gain and Phase Shift vs Frequency

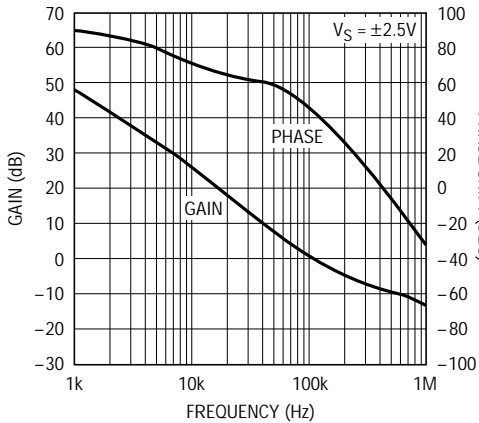

1636 G10

Gain-Bandwidth Product vs Temperature

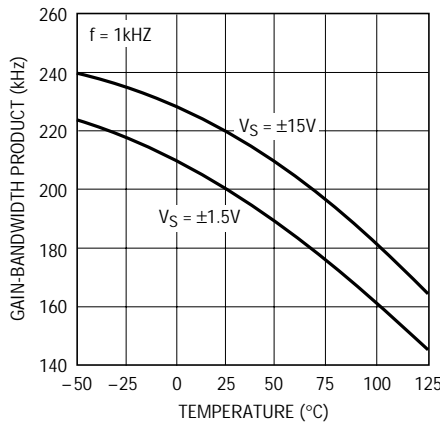

1636 G11

Slew Rate vs Temperature

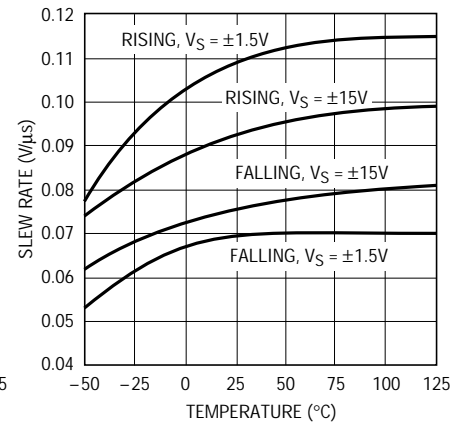

1636 G12

Gain-Bandwidth Product and Phase Margin vs Supply Voltage

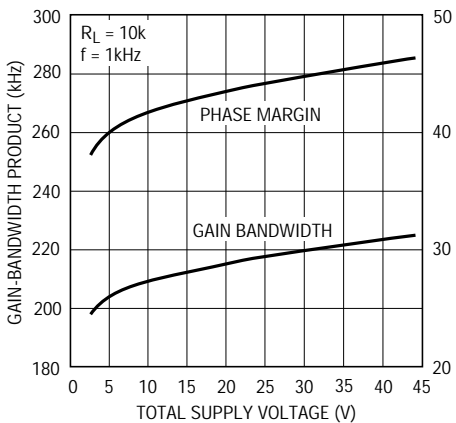

1636 G13

CMRR vs Frequency

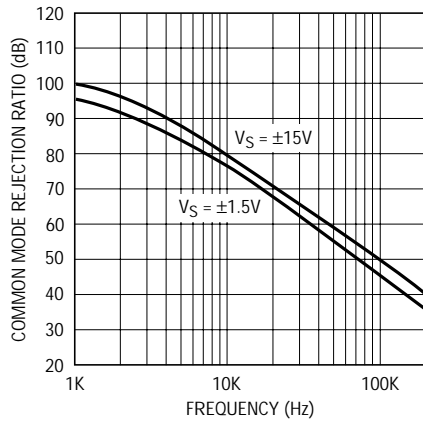

1636 G14

PSRR vs Frequency

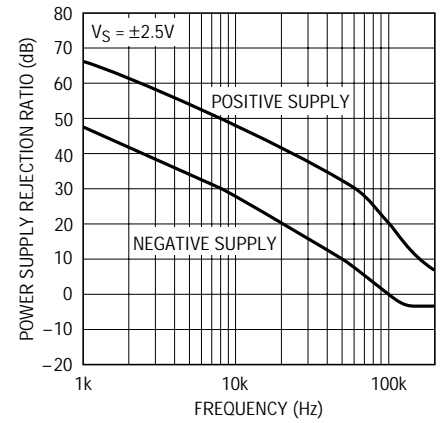

1636 G15

# TYPICAL PERFORMANCE CHARACTERISTICS

**Gain-Bandwidth Product and Phase Margin vs Load Resistance**

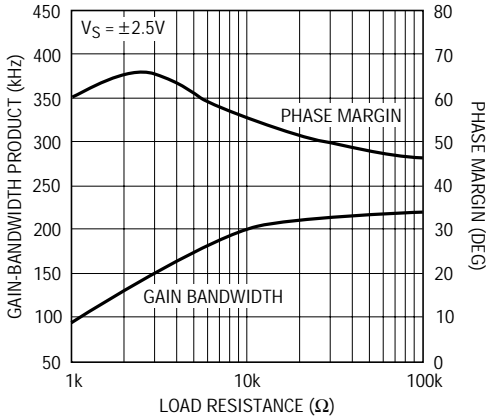

1636 G16

**Output Impedance vs Frequency**

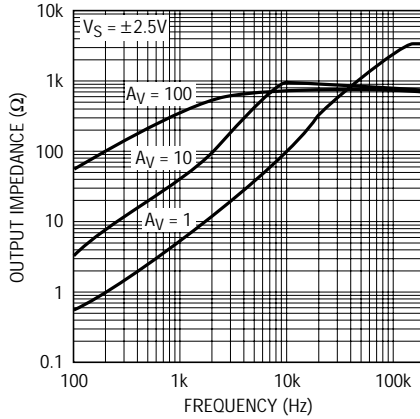

1635 G17

**Undistorted Output Swing vs Frequency**

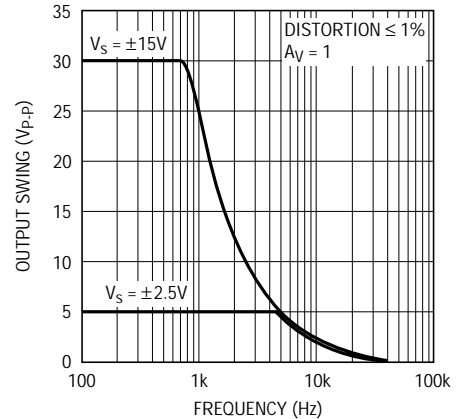

1635 G18

**Settling Time to 0.1% vs Output Step**

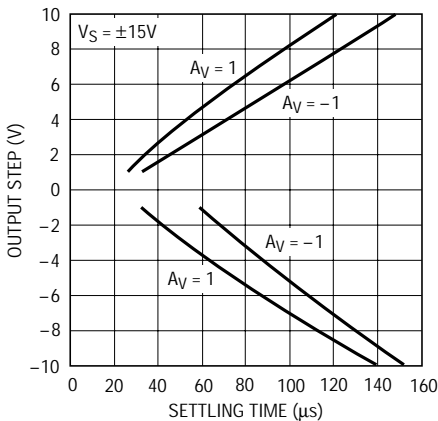

1636 G19

**Capacitive Load Handling, Overshoot vs Capacitive Load**

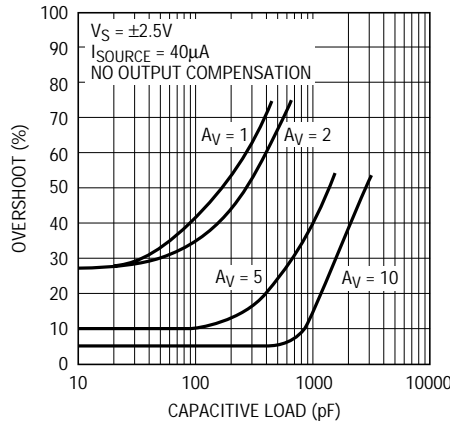

1636 G20

**Total Harmonic Distortion + Noise vs Frequency**

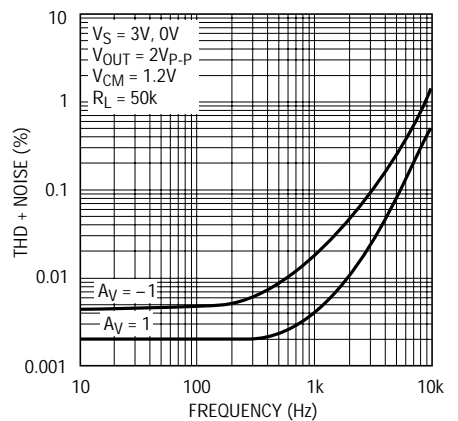

1636 G21

**Total Harmonic Distortion + Noise vs Load Resistance**

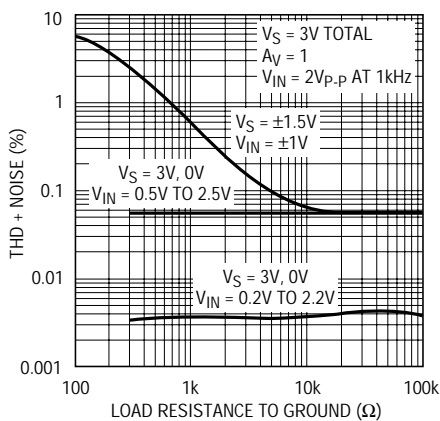

1636 G22

**Total Harmonic Distortion + Noise vs Output Voltage**

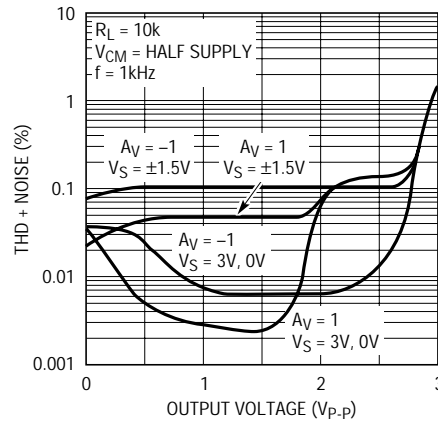

1636 G23



## TYPICAL PERFORMANCE CHARACTERISTICS

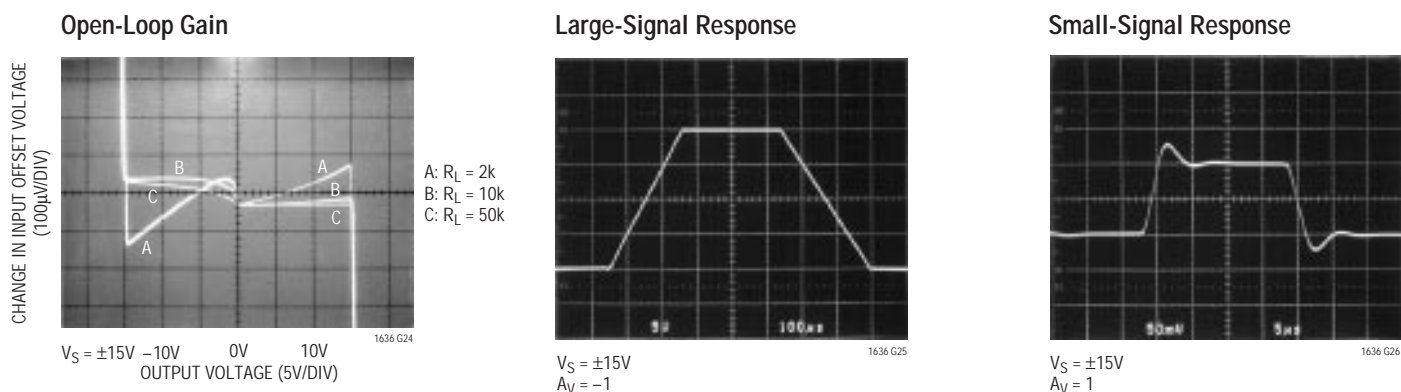

## APPLICATIONS INFORMATION

### Supply Voltage

The positive supply pin of the LT1636 should be bypassed with a small capacitor (about 0.01µF) within an inch of the pin. When driving heavy loads an additional 4.7µF electrolytic capacitor should be used. When using split supplies, the same is true for the negative supply pin.

The LT1636 is protected against reverse battery voltages up to 27V. In the event a reverse battery condition occurs, the supply current is less than 1nA.

When operating the LT1636 on total supplies of 20V or more, the supply must not be brought up faster than 1µs. This is especially true if low ESR bypass capacitors are used. A series RLC circuit is formed from the supply lead inductance and the bypass capacitor. 5Ω of resistance in the supply or the bypass capacitor will dampen the tuned circuit enough to limit the rise time.

### Inputs

The LT1636 has two input stages, NPN and PNP (see Simplified Schematic), resulting in three distinct operating regions as shown in the Input Bias Current vs Common Mode typical performance curve.

For input voltages about 0.8V or more below  $V^+$ , the PNP input stage is active and the input bias current is typically -4nA. When the input voltage is about 0.5V or less from  $V^+$ , the NPN input stage is operating and the input bias current is typically 10nA. Increases in temperature will

cause the voltage at which operation switches from the PNP stage to the NPN stage to move towards  $V^+$ . The input offset voltage of the NPN stage is untrimmed and is typically 600µV.

A Schottky diode in the collector of each NPN transistor of the NPN input stage allows the LT1636 to operate with either or both of its inputs above  $V^+$ . At about 0.3V above  $V^+$  the NPN input transistor is fully saturated and the input bias current is typically 3µA at room temperature. The input offset voltage is typically 600µV when operating above  $V^+$ . The LT1636 will operate with its input 44V above  $V^-$  regardless of  $V^+$ .

The inputs are protected against excursions as much as 22V below  $V^-$  by an internal 1k resistor in series with each input and a diode from the input to the negative supply. There is no output phase reversal for inputs up to 5V below  $V^-$ . There are no clamping diodes between the inputs and the maximum differential input voltage is 44V.

### Output

The output voltage swing of the LT1636 is affected by input overdrive as shown in the typical performance curves. When monitoring voltages within 100mV of  $V^+$ , gain should be taken to keep the output from clipping.

The output of the LT1636 can be pulled up to 27V beyond  $V^+$  with less than 1nA of leakage current, provided that  $V^+$  is less than 0.5V.



## APPLICATIONS INFORMATION

The normally reverse biased substrate diode from the output to  $V^-$  will cause unlimited currents to flow when the output is forced below  $V^-$ . If the current is transient and limited to 100mA, no damage will occur.

The LT1636 is internally compensated to drive at least 200pF of capacitance under any output loading conditions. A 0.22 $\mu$ F capacitor in series with a 150 $\Omega$  resistor between the output and ground will compensate these amplifiers for larger capacitive loads, up to 10,000pF, at all output currents.

### Distortion

There are two main contributors of distortion in op amps: output crossover distortion as the output transitions from sourcing to sinking current and distortion caused by nonlinear common mode rejection. Of course, if the op amp is operating inverting there is no common mode induced distortion. When the LT1636 switches between input stages there is significant nonlinearity in the CMRR. Lower load resistance increases the output crossover distortion, but has no effect on the input stage transition distortion. For lowest distortion the LT1636 should be operated single supply, with the output always sourcing current and with the input voltage swing between ground and ( $V^+ - 0.8V$ ). See the Typical Performance Characteristics curves.

### Gain

The open-loop gain is less sensitive to load resistance when the output is sourcing current. This optimizes performance in single supply applications where the load is

returned to ground. The typical performance photo of Open-Loop Gain for various loads shows the details.

### Shutdown

The LT1636 can be shut down two ways: using the shutdown pin or bringing  $V^+$  to within 0.5V of  $V^-$ . When  $V^+$  is brought to within 0.5V of  $V^-$  both the supply current and output leakage current drop to less than 1nA. When the shutdown pin is brought 1.2V above  $V^-$ , the supply current drops to about 4 $\mu$ A and the output leakage current is less than 1 $\mu$ A, independent of  $V^+$ . In either case the input bias current is less than 0.1nA (even if the inputs are 44V above the negative supply).

The shutdown pin can be taken up to 32V above  $V^-$ . The shutdown pin can be driven below  $V^-$ , however the pin current through the substrate diode should be limited with an external resistor to less than 10mA.

### Input Offset Nulling

The input offset voltage can be nulled by placing a 10k potentiometer between Pins 1 and 8 with its wiper to  $V^-$  (see Figure 1). The null range will be at least  $\pm 1mV$ .

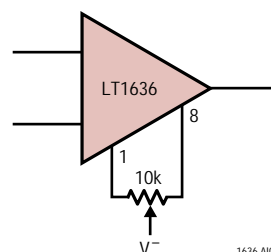
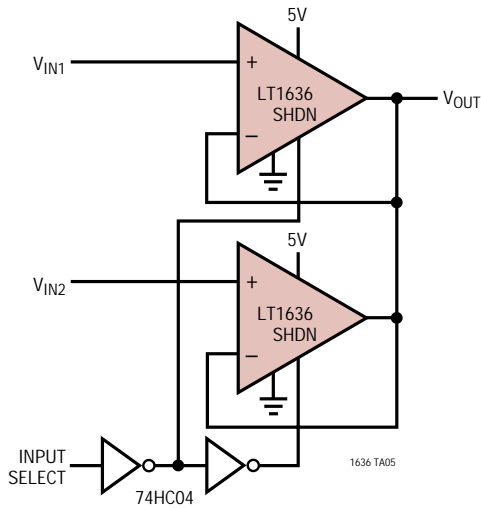

Figure 1. Input Offset Nulling

# TYPICAL APPLICATIONS

MUX Amplifier



MUX Amplifier Waveforms

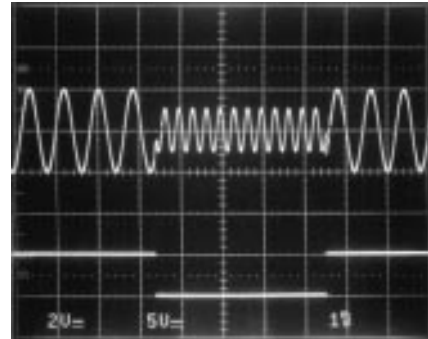

$V_S = 5V$   
 $V_{IN1} = 1.2kHz$  AT  $4V_{p-p}$ ,  $V_{IN2} = 2.4kHz$  AT  $2V_{p-p}$   
 INPUT SELECT =  $120Hz$  AT  $5V_{p-p}$

Optional Output Compensation for Capacitive Loads Greater Than 200pF

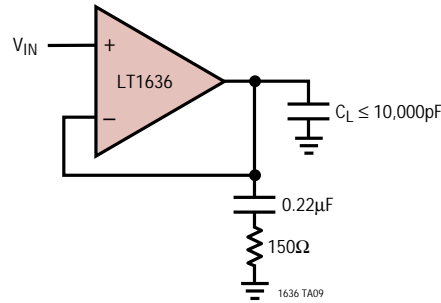

# SIMPLIFIED SCHEMATIC

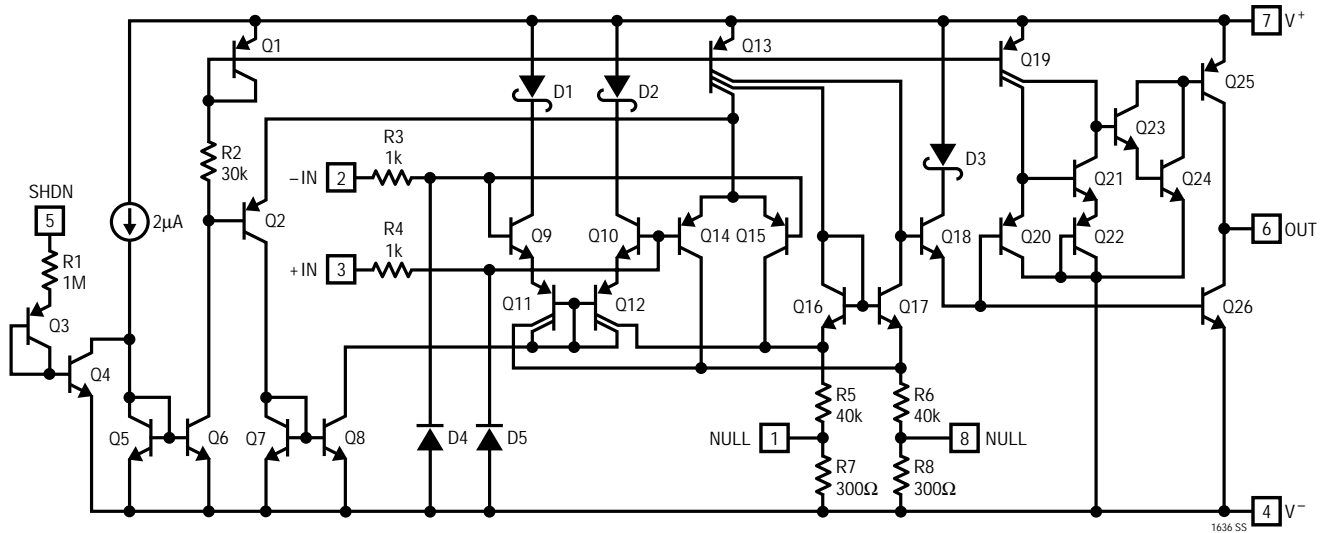

**PACKAGE DESCRIPTION** Dimensions in inches (millimeters) unless otherwise noted.

**MS8 Package**  
**8-Lead Plastic MSOP**  
 (LTC DWG # 05-08-1660)

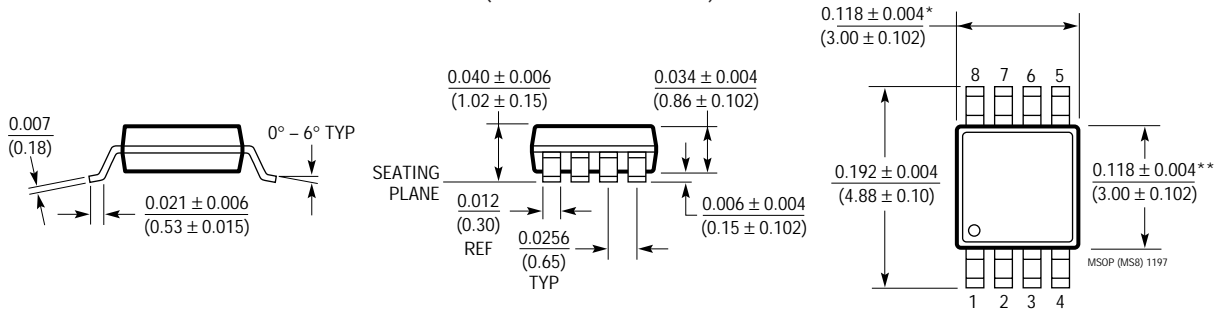

\* DIMENSION DOES NOT INCLUDE MOLD FLASH, PROTRUSIONS OR GATE BURRS. MOLD FLASH, PROTRUSIONS OR GATE BURRS SHALL NOT EXCEED 0.006\* (0.152mm) PER SIDE  
 \*\* DIMENSION DOES NOT INCLUDE INTERLEAD FLASH OR PROTRUSIONS. INTERLEAD FLASH OR PROTRUSIONS SHALL NOT EXCEED 0.006\* (0.152mm) PER SIDE

**N8 Package**  
**8-Lead PDIP (Narrow 0.300)**  
 (LTC DWG # 05-08-1510)

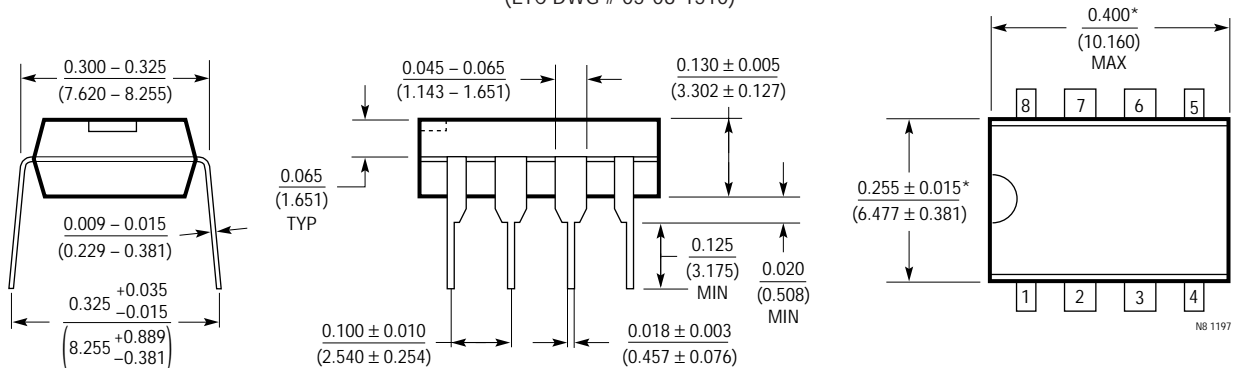

\*THESE DIMENSIONS DO NOT INCLUDE MOLD FLASH OR PROTRUSIONS. MOLD FLASH OR PROTRUSIONS SHALL NOT EXCEED 0.010 INCH (0.254mm)

**S8 Package**  
**8-Lead Plastic Small Outline (Narrow 0.150)**  
 (LTC DWG # 05-08-1610)

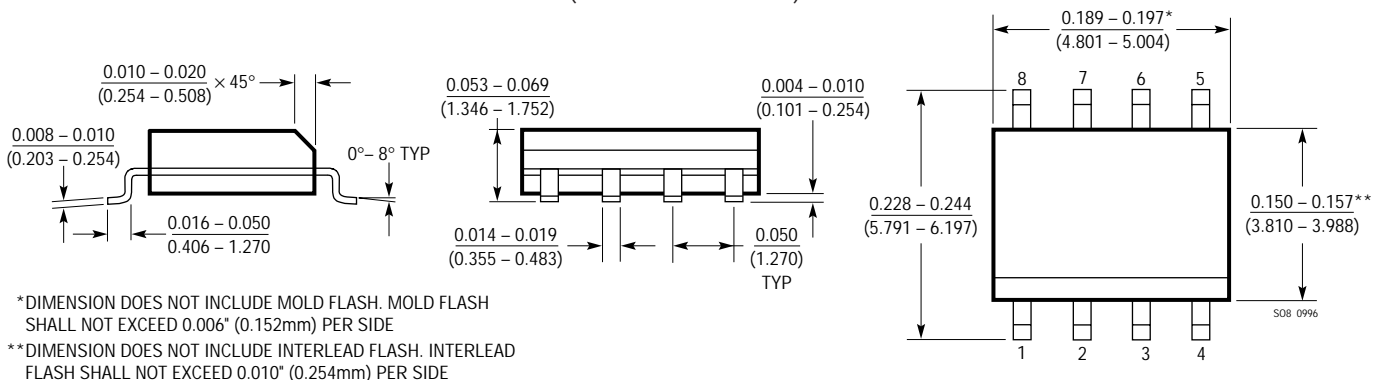

\* DIMENSION DOES NOT INCLUDE MOLD FLASH. MOLD FLASH SHALL NOT EXCEED 0.006\* (0.152mm) PER SIDE  
 \*\* DIMENSION DOES NOT INCLUDE INTERLEAD FLASH. INTERLEAD FLASH SHALL NOT EXCEED 0.010\* (0.254mm) PER SIDE

TYPICAL APPLICATIONS

Over-The-Top Comparator with Hysteresis

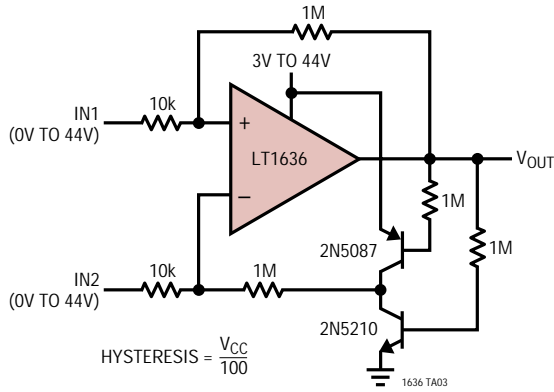

Self-Buffered Micropower Reference

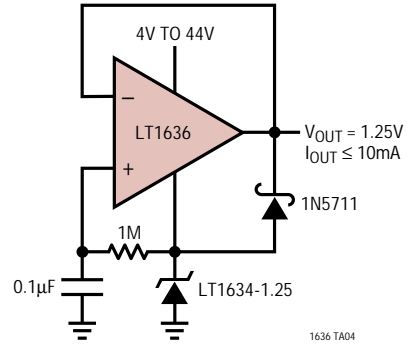

Lamp Outage Detector

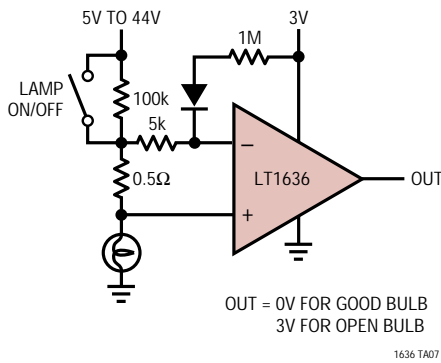

Over-The-Top Current Sense

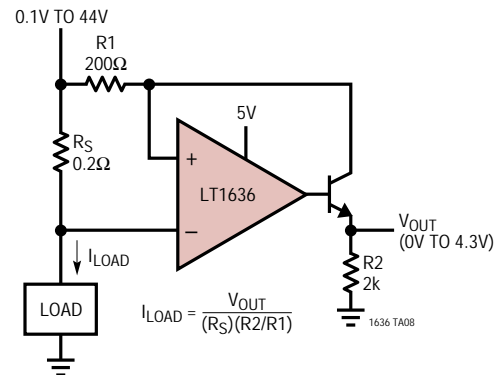

RELATED PARTS

PART NUMBER	DESCRIPTION	COMMENTS
LT1460	Micropower Precision Series Reference	Accuracy: 0.075% Max, Drift: 10ppm/°C Max, 2.5V, 5V, 10V Versions Available
LT1466/LT1467	75µA Dual/Quad Rail-to-Rail Input and Output Op Amps	390µV $V_{OS(MAX)}$ , Gain Bandwidth = 120kHz
LT1490/LT1491	50µA Dual/Quad Rail-to-Rail Input and Output Op Amps	950µV $V_{OS(MAX)}$ , Gain Bandwidth = 200kHz
LT1495/LT1496	1.5µA Max, Dual/Quad Precision Rail-to-Rail Input and Output Op Amps	375µV $V_{OS(MAX)}$ , 1.5µA Supply Current Max
LT2078/LT2079	55µA Dual/Quad Precision Single Supply Op Amps	120µV $V_{OS(MAX)}$ , Gain Bandwidth = 200kHz
LT2178/LT2179	17µA Dual/Quad Precision Single Supply Op Amps	120µV $V_{OS(MAX)}$ , Gain Bandwidth = 60kHz