



PSoC TRM

CY8CPLC20, CY8CLED16P01, CY8C29x66,
CY8C27x43, CY8C24x94, CY8C24x23, CY8C24x23A,
CY8C22x13, CY8C21x34, CY8C21x23,
CY7C64215, CY7C603xx, CY8CNP1xx, and
CYWUSB6953

PSoC[®] Programmable System-on-Chip

Technical Reference Manual (TRM)

PSoC TRM, Document No. 001-14463 Rev. *D

Cypress Semiconductor Corporation
198 Champion Court
San Jose, CA 95134
Phone (USA): 800.858.1810
Phone (Intl.): 408.943.2600
<http://www.cypress.com>

Copyrights

Copyright © 2005 - 2009 Cypress Semiconductor Corporation. All rights reserved.

PSoC® is a registered trademark and PSoC Designer™ and Programmable System-on-Chip™ are trademarks of Cypress Semiconductor Corporation (Cypress), along with Cypress® and Cypress Semiconductor™. All other trademarks or registered trademarks referenced herein are the property of their respective owners.

Purchase of I²C components from Cypress or one of its sublicensed Associated Companies conveys a license under the Philips I²C Patent Rights to use these components in an I²C system, provided that the system conforms to the I²C Standard Specification as defined by Philips.

Any Source Code (software and/or firmware) is owned by Cypress Semiconductor Corporation (Cypress) and is protected by and subject to worldwide patent protection (United States and foreign), United States copyright laws and international treaty provisions. Cypress hereby grants to licensee a personal, non-exclusive, non-transferable license to copy, use, modify, create derivative works of, and compile the Cypress Source Code and derivative works for the sole purpose of creating custom software and or firmware in support of licensee product to be used only in conjunction with a Cypress integrated circuit as specified in the applicable agreement. Any reproduction, modification, translation, compilation, or representation of this Source Code except as specified above is prohibited without the express written permission of Cypress.

Disclaimer: CYPRESS MAKES NO WARRANTY OF ANY KIND, EXPRESS OR IMPLIED, WITH REGARD TO THIS MATERIAL, INCLUDING, BUT NOT LIMITED TO, THE IMPLIED WARRANTIES OF MERCHANTABILITY AND FITNESS FOR A PARTICULAR PURPOSE. Cypress reserves the right to make changes without further notice to the materials described herein. Cypress does not assume any liability arising out of the application or use of any product or circuit described herein. Cypress does not authorize its products for use as critical components in life-support systems where a malfunction or failure may reasonably be expected to result in significant injury to the user. The inclusion of Cypress' product in a life-support systems application implies that the manufacturer assumes all risk of such use and in doing so indemnifies Cypress against all charges.

Use may be limited by and subject to the applicable Cypress software license agreement.

The information in this document is subject to change without notice and should not be construed as a commitment by Cypress. While reasonable precautions have been taken, Cypress assumes no responsibility for any errors that may appear in this document. No part of this document may be copied or reproduced in any form or by any means without the prior written consent of Cypress. Made in the U.S.A.

Disclaimer

CYPRESS MAKES NO WARRANTY OF ANY KIND, EXPRESS OR IMPLIED, WITH REGARD TO THIS MATERIAL, INCLUDING, BUT NOT LIMITED TO, THE IMPLIED WARRANTIES OF MERCHANTABILITY AND FITNESS FOR A PARTICULAR PURPOSE. Cypress reserves the right to make changes without further notice to the materials described herein. Cypress does not assume any liability arising out of the application or use of any product or circuit described herein. Cypress does not authorize its products for use as critical components in life-support systems where a malfunction or failure may reasonably be expected to result in significant injury to the user. The inclusion of Cypress' product in a life-support systems application implies that the manufacturer assumes all risk of such use and in doing so indemnifies Cypress against all charges.

Flash Code Protection

Note the following details of the Flash code protection features on Cypress devices.

Cypress products meet the specifications contained in their particular Cypress Data Sheets. Cypress believes that its family of products is one of the most secure families of its kind on the market today, regardless of how they are used. There may be methods, unknown to Cypress, that can breach the code protection features. Any of these methods, to our knowledge, would be dishonest and possibly illegal. Neither Cypress nor any other semiconductor manufacturer can guarantee the security of their code. Code protection does not mean that we are guaranteeing the product as "unbreakable."

Cypress is willing to work with the customer who is concerned about the integrity of their code. Code protection is constantly evolving. We at Cypress are committed to continuously improving the code protection features of our products.

Contents Overview



Section A: Overview	19
1. Pin Information	29
Section B: PSoC Core	59
2. CPU Core (M8C)	63
3. Supervisory ROM (SROM)	73
4. RAM Paging	85
5. Interrupt Controller	95
6. General Purpose IO (GPIO)	103
7. Analog Output Drivers	111
8. Internal Main Oscillator (IMO)	113
9. Internal Low Speed Oscillator (ILO)	117
10. External Crystal Oscillator (ECO)	119
11. Phase-Locked Loop (PLL)	125
12. Sleep and Watchdog	129
Section C: Register Reference	141
13. Register Details	147
Section D: Digital System	307
14. Global Digital Interconnect (GDI)	313
15. Array Digital Interconnect (ADI)	325
16. Row Digital Interconnect (RDI)	327
17. Digital Blocks	335
Section E: Analog System	371
18. Analog Interface	377
19. Analog Array	395
20. Analog Input Configuration	403
21. Analog Reference	411
22. Continuous Time PSoC Block	415
23. Switched Capacitor PSoC Block	421
24. Two Column Limited Analog System	431
Section F: System Resources	453
25. Digital Clocks	459
26. Multiply Accumulate (MAC)	469
27. Decimator	475
28. I2C	483

29. Internal Voltage Reference	499
30. System Resets.....	501
31. Switch Mode Pump (SMP).....	509
32. POR and LVD	513
33. IO Analog Multiplexer.....	517
34. Full-Speed USB	523
35. nvSRAM	539
Section G: Glossary	541
Index	557

Contents



Section A: Overview	19
Document Organization	19
Top Level Architecture	20
PSoC Core	20
Digital System	20
Analog System	20
System Resources	20
PSoC Device Characteristics	22
PSoC Device Distinctions	23
Getting Started	24
Support	24
Product Upgrades	24
Development Kits	24
Document History	25
Documentation Conventions	26
Register Conventions	26
Numeric Naming	26
Units of Measure	26
Acronyms	27
1. Pin Information	29
1.1 Pinouts	29
1.1.1 8-Pin Part Pinouts	29
1.1.2 16-Pin Part Pinout	30
1.1.3 20-Pin Part Pinouts	31
1.1.4 24-Pin Part Pinout	32
1.1.5 28-Pin Part Pinouts	33
1.1.6 32-Pin Part Pinouts	35
1.1.7 44-Pin Part Pinout	37
1.1.8 48-Pin Part Pinouts	38
1.1.9 56-Pin Part Pinouts	41
1.1.10 68-Pin Part Pinouts	45
1.1.11 100-Pin Part Pinouts	47
1.1.12 VFBGA Part Pinouts	55
Section B: PSoC Core	59
Top Level Core Architecture	59
Interpreting the Core Documentation	59
Core Register Summary	60
2. CPU Core (M8C)	63
2.1 Overview	63

2.2	Internal Registers	63
2.3	Address Spaces	63
2.4	Instruction Set Summary	64
2.5	Instruction Formats	66
2.5.1	One-Byte Instructions	66
2.5.2	Two-Byte Instructions	66
2.5.3	Three-Byte Instructions	67
2.6	Addressing Modes	67
2.6.1	Source Immediate	67
2.6.2	Source Direct	68
2.6.3	Source Indexed	68
2.6.4	Destination Direct	69
2.6.5	Destination Indexed	69
2.6.6	Destination Direct Source Immediate	69
2.6.7	Destination Indexed Source Immediate	70
2.6.8	Destination Direct Source Direct	70
2.6.9	Source Indirect Post Increment	71
2.6.10	Destination Indirect Post Increment	71
2.7	Register Definitions	72
2.7.1	CPU_F Register	72
3.	Supervisory ROM (SROM)	73
3.1	Architectural Description	73
3.1.1	Additional SROM Feature	74
3.1.2	SROM Function Descriptions	74
3.1.2.1	SWBootReset Function	74
3.1.2.2	ReadBlock Function	75
3.1.2.3	WriteBlock Function	75
3.1.2.4	EraseBlock Function	76
3.1.2.5	ProtectBlock Function	76
3.1.2.6	TableRead Function	77
3.1.2.7	EraseAll Function	77
3.1.2.8	Checksum Function	77
3.1.2.9	Calibrate0 Function	77
3.1.2.10	Calibrate1 Function	78
3.2	PSoC Device Distinctions	78
3.3	Register Definitions	78
3.3.1	STK_PP Register	79
3.3.2	MVR_PP Register	80
3.3.3	MVW_PP Register	80
3.3.4	CPU_SCR1 Register	81
3.3.5	FLS_PR1 Register	82
3.4	Clocking	83
3.4.1	DELAY Parameter	83
3.4.2	CLOCK Parameter	83
4.	RAM Paging	85
4.1	Architectural Description	85
4.1.1	Basic Paging	86
4.1.2	Stack Operations	86
4.1.3	Interrupts	87
4.1.4	MVI Instructions	87
4.1.5	Current Page Pointer	87
4.1.6	Index Memory Page Pointer	87
4.2	Register Definitions	89

4.2.1	TMP_DRx Registers	89
4.2.2	CUR_PP Register	89
4.2.3	STK_PP Register	90
4.2.4	IDX_PP Register	91
4.2.5	MVR_PP Register	91
4.2.6	MVW_PP Register	92
4.2.7	CPU_F Register	93
5.	Interrupt Controller	95
5.1	Architectural Description	95
5.1.1	Posted versus Pending Interrupts	96
5.2	Application Description	97
5.3	Register Definitions	98
5.3.1	INT_CLRx Registers	98
5.3.1.1	INT_CLR0 Register	98
5.3.1.2	INT_CLR1 Register	99
5.3.1.3	INT_CLR2 Register	99
5.3.1.4	INT_CLR3 Register	99
5.3.2	INT_MSKx Registers	100
5.3.2.1	INT_MSK3 Register	100
5.3.2.2	INT_MSK2 Register	100
5.3.2.3	INT_MSK0 Register	101
5.3.2.4	INT_MSK1 Register	101
5.3.3	INT_VC Register	102
5.3.4	CPU_F Register	102
6.	General Purpose IO (GPIO)	103
6.1	Architectural Description	103
6.1.1	Digital IO	103
6.1.2	Global IO	104
6.1.3	Analog Input	104
6.1.4	GPIO Block Interrupts	106
6.2	Register Definitions	107
6.2.1	PRTxDR Registers	107
6.2.2	PRTxIE Registers	108
6.2.3	PRTxGS Registers	108
6.2.4	PRTxDMx Registers	109
6.2.5	PRTxICx Registers	109
7.	Analog Output Drivers	111
7.1	Architectural Description	111
7.2	Register Definitions	112
7.2.1	ABF_CR0 Register	112
8.	Internal Main Oscillator (IMO)	113
8.1	Architectural Description	113
8.2	PSoC Device Distinctions	113
8.3	Application Description	113
8.3.1	Trimming the IMO	114
8.3.2	Engaging Slow IMO (SLIMO)	114
8.4	Register Definitions	115
8.4.1	CPU_SCR1 Register	115
8.4.2	OSC_CR2 Register	116
8.4.3	IMO_TR Register	116

9. Internal Low Speed Oscillator (ILO)	117
9.1 Architectural Description	117
9.2 Register Definitions	117
9.2.1 ILO_TR Register	117
10. External Crystal Oscillator (ECO)	119
10.1 Architectural Description	119
10.1.1 ECO External Components	120
10.2 PSoC Device Distinctions	120
10.3 Register Definitions	121
10.3.1 CPU_SCR1 Register	121
10.3.2 OSC_CR0 Register	122
10.3.3 ECO_TR Register	123
11. Phase-Locked Loop (PLL)	125
11.1 Architectural Description	125
11.2 Register Definitions	125
11.2.1 OSC_CR0 Register	126
11.2.2 OSC_CR2 Register	127
12. Sleep and Watchdog	129
12.1 Architectural Description	129
12.1.1 32 kHz Clock Selection	129
12.1.2 Sleep Timer	129
12.2 Application Description	130
12.3 Register Definitions	131
12.3.1 INT_MSK0 Register	131
12.3.2 RES_WDT Register	131
12.3.3 CPU_SCR1 Register	132
12.3.4 CPU_SCR0 Register	133
12.3.5 OSC_CR0 Register	134
12.3.6 ILO_TR Register	135
12.3.7 ECO_TR Register	135
12.4 Timing Diagrams	136
12.4.1 Sleep Sequence	136
12.4.2 Wake Up Sequence	137
12.4.3 Bandgap Refresh	138
12.4.4 Watchdog Timer	138
12.5 Power Consumption	139
Section C: Register Reference	141
Register General Conventions	141
Register Naming Conventions	141
Register Mapping Tables	141
Register Map Bank 0 Table: User Space	142
Register Map Bank 1 Table: Configuration Space	143
Register Map Bank 0 Table for USB: User Space	144
Register Map Bank 1 Table for USB: Configuration Space	145
13. Register Details	147
13.1 Maneuvering Around the Registers	147
Register Conventions	148
13.1.1 Register Naming Conventions	148
13.2 Bank 0 Registers	149
13.2.1 PRTxDR	149

13.2.2	PRTxIE	150
13.2.3	PRTxGS	151
13.2.4	PRTxDM2	152
13.2.5	DxBxxDR0	153
13.2.6	DxBxxDR1	154
13.2.7	DxBxxDR2	155
13.2.8	DxBxxCR0 (Timer Control)	156
13.2.9	DxBxxCR0 (Counter Control)	157
13.2.10	DxBxxCR0 (Dead Band Control)	158
13.2.11	DxBxxCR0 (CRCPRS Control)	159
13.2.12	DCBxxCR0 (SPIM Control)	160
13.2.13	DCBxxCR0 (SPIS Control)	161
13.2.14	DCBxxCR0 (UART Transmitter Control)	162
13.2.15	DCBxxCR0 (UART Receiver Control)	163
13.2.16	PMAx_DR	164
13.2.17	USB_SOF0	165
13.2.18	USB_SOF1	166
13.2.19	USB_CR0	167
13.2.20	USBIO_CR0	168
13.2.21	USBIO_CR1	169
13.2.22	EPx_CNT1	170
13.2.23	EPx_CNT	171
13.2.24	EP0_CR	172
13.2.25	EP0_CNT	173
13.2.26	EP0_DRx	174
13.2.27	AMX_IN	175
13.2.28	AMUX_CFG	177
13.2.29	PWM_CR	178
13.2.30	ARF_CR	179
13.2.31	CMP_CR0	180
13.2.32	ASY_CR	182
13.2.33	CMP_CR1	183
13.2.34	ADCx_CR	185
13.2.35	TMP_DRx	186
13.2.36	ACBxxCR3	187
13.2.37	ACBxxCR0	188
13.2.38	ACBxxCR1	190
13.2.39	ACExxCR1	192
13.2.40	ACBxxCR2	193
13.2.41	ACExxCR2	194
13.2.42	ASCxxCR0	195
13.2.43	ASExxCR0	196
13.2.44	ASCxxCR1	197
13.2.45	ASCxxCR2	198
13.2.46	ASCxxCR3	199
13.2.47	ASDxxCR0	200
13.2.48	ASDxxCR1	201
13.2.49	ASDxxCR2	202
13.2.50	ASDxxCR3	203
13.2.51	MULx_X	204
13.2.52	MULx_Y	205
13.2.53	MULx_DH	206
13.2.54	MULx_DL	207
13.2.55	MACx_X/ACCx_DR1	208

13.2.56	MACx_Y/ACCx_DR0	209
13.2.57	MACx_CL0/ACCx_DR3	210
13.2.58	MACx_CL1/ACCx_DR2	211
13.2.59	RDixRI	212
13.2.60	RDixSYN	213
13.2.61	RDixIS	214
13.2.62	RDixLT0	215
13.2.63	RDixLT1	216
13.2.64	RDixRO0	217
13.2.65	RDixRO1	218
13.2.66	CUR_PP	219
13.2.67	STK_PP	220
13.2.68	IDX_PP	221
13.2.69	MVR_PP	222
13.2.70	MVW_PP	223
13.2.71	I2C_CFG	224
13.2.72	I2C_SCR	225
13.2.73	I2C_DR	227
13.2.74	I2C_MSCR	228
13.2.75	INT_CLR0	229
13.2.76	INT_CLR1	231
13.2.77	INT_CLR2	233
13.2.78	INT_CLR3	235
13.2.79	INT_MSK3	236
13.2.80	INT_MSK2	237
13.2.81	INT_MSK0	239
13.2.82	INT_MSK1	240
13.2.83	INT_VC	241
13.2.84	RES_WDT	242
13.2.85	DEC_DH	243
13.2.86	DEC_DL	244
13.2.87	DEC_CR0	245
13.2.88	DEC_CR1	247
13.2.89	CPU_F	249
13.2.90	DAC_D	250
13.2.91	CPU_SCR1	251
13.2.92	CPU_SCR0	252
13.3	Bank 1 Registers	253
13.3.1	PRTxDM0	253
13.3.2	PRTxDM1	254
13.3.3	PRTxIC0	255
13.3.4	PRTxIC1	256
13.3.5	DxBxxFN	257
13.3.6	DxBxxIN	259
13.3.7	DxBxxOU	261
13.3.8	PMAx_WA	263
13.3.9	PMAx_RA	264
13.3.10	CLK_CR0	265
13.3.11	CLK_CR1	266
13.3.12	ABF_CR0	267
13.3.13	AMD_CR0	269
13.3.14	CMP_GO_EN	271
13.3.15	CMP_GO_EN1	272
13.3.16	AMD_CR1	273

13.3.17	ALT_CR0	275
13.3.18	ALT_CR1	277
13.3.19	CLK_CR2	278
13.3.20	CLK_CR3	279
13.3.21	AMUX_CLK	280
13.3.22	USB_CR1	281
13.3.23	EPx_CR0	282
13.3.24	GDI_O_IN	283
13.3.25	GDI_E_IN	284
13.3.26	GDI_O_OU	285
13.3.27	GDI_E_OU	286
13.3.28	MUX_CRx	287
13.3.29	OSC_GO_EN	288
13.3.30	OSC_CR4	289
13.3.31	OSC_CR3	290
13.3.32	OSC_CR0	291
13.3.33	OSC_CR1	292
13.3.34	OSC_CR2	293
13.3.35	VLT_CR	294
13.3.36	VLT_CMP	295
13.3.37	ADCx_TR	296
13.3.38	DEC_CR2	297
13.3.39	IMO_TR	298
13.3.40	ILO_TR	299
13.3.41	BDG_TR	300
13.3.42	ECO_TR	301
13.3.43	IMO_TR1	302
13.3.44	IMO_TR2	303
13.3.45	FLS_PR1	304
13.3.46	DAC_CR	305

Section D: Digital System	307
Top Level Digital Architecture	307
Interpreting the Digital Documentation	307
Digital Register Summary	308

14. Global Digital Interconnect (GDI)	313
14.1 Architectural Description	313
14.1.1 8-Pin Global Interconnect	314
14.1.2 16-Pin Global Interconnect	315
14.1.3 20- to 24-Pin Global Interconnect	316
14.1.4 28- to 32-Pin Global Interconnect	317
14.1.4.1 32-Pin GDI for the CY8C21x34, CY7C603xx, and CYWUSB6953	318
14.1.5 44-Pin Global Interconnect	319
14.1.6 48-Pin Global Interconnect	320
14.1.7 56-Pin Global Interconnect for the CY8C24x94 and CY7C64215	321
14.1.8 100-Pin Global Interconnect	322
14.2 Register Definitions	323
14.2.1 GDI_x_IN Registers	323
14.2.2 GDI_x_OU Registers	324

15. Array Digital Interconnect (ADI)	325
15.1 Architectural Description	325

16. Row Digital Interconnect (RDI)	327
16.1 Architectural Description	327
16.2 PSoC Device Distinctions.....	328
16.3 Register Definitions	329
16.3.1 RDlXRI Register	329
16.3.2 RDlXSYN Register	330
16.3.3 RDlXIS Register	331
16.3.4 RDlXLTx Registers	332
16.3.5 RDlXROx Registers	333
16.3.5.1 RDlXRO0 Register.....	333
16.3.5.2 RDlXRO1 Register.....	333
16.4 Timing Diagram	334
17. Digital Blocks	335
17.1 Architectural Description	335
17.1.1 Input Multiplexers	336
17.1.2 Input Clock Resynchronization	336
17.1.2.1 Clock Resynchronization Summary.....	337
17.1.3 Output De-Multiplexers	337
17.1.4 Block Chaining Signals	337
17.1.5 Input Data Synchronization.....	337
17.1.6 Timer Function	337
17.1.6.1 Usability Exceptions.....	337
17.1.6.2 Block Interrupt.....	337
17.1.7 Counter Function	338
17.1.7.1 Usability Exceptions.....	338
17.1.7.2 Block Interrupt.....	338
17.1.8 Dead Band Function	338
17.1.8.1 Usability Exceptions.....	339
17.1.8.2 Block Interrupt.....	339
17.1.9 CRCPRS Function	339
17.1.9.1 Usability Exceptions.....	341
17.1.9.2 Block Interrupt.....	341
17.1.10 SPI Protocol Function	341
17.1.10.1 SPI Protocol Signal Definitions.....	341
17.1.11 SPI Master Function	342
17.1.11.1 Usability Exceptions.....	342
17.1.11.2 Block Interrupt.....	342
17.1.12 SPI Slave Function	342
17.1.12.1 Usability Exceptions.....	342
17.1.12.2 Block Interrupt.....	343
17.1.13 Asynchronous Transmitter and Receiver Functions	343
17.1.13.1 Asynchronous Transmitter Function.....	343
17.1.13.2 Usability Exceptions.....	343
17.1.13.3 Block Interrupt.....	343
17.1.13.4 Asynchronous Receiver Function.....	344
17.1.13.5 Usability Exceptions.....	344
17.1.13.6 Block Interrupt.....	344
17.2 Register Definitions	345
17.2.1 DxBxxDRx Registers	346
17.2.1.1 Timer Register Definitions	346
17.2.1.2 Counter Register Definitions.....	347
17.2.1.3 Dead Band Register Definitions.....	347
17.2.1.4 CRCPRS Register Definitions	348
17.2.1.5 SPI Master Register Definitions.....	348

	17.2.1.6	SPI Slave Register Definitions	349
	17.2.1.7	Transmitter Register Definitions.....	349
	17.2.1.8	Receiver Register Definitions.....	349
	17.2.2	DxBxxCR0 Register	350
	17.2.3	INT_MSK2 Register	351
	17.2.4	INT_MSK1 Register	351
	17.2.5	DxBxxFN Registers	352
	17.2.6	DxBxxIN Registers	353
	17.2.7	DxBxxOU Registers	353
17.3		Timing Diagrams	355
	17.3.1	Timer Timing	355
	17.3.2	Counter Timing	356
	17.3.3	Dead Band Timing	357
		17.3.3.1 Changing the PWM Duty Cycle	357
		17.3.3.2 Kill Operation	358
	17.3.4	CRCPRS Timing	359
	17.3.5	SPI Mode Timing	359
	17.3.6	SPIM Timing	360
	17.3.7	SPIS Timing	363
	17.3.8	Transmitter Timing	366
	17.3.9	Receiver Timing	368

Section E: Analog System 371

	Top Level Analog Architecture	371
	Interpreting the Analog Documentation	371
	Application Description	372
	Defining the Analog Blocks	372
	Analog Functionality	372
	Analog Register Summary	373

18. Analog Interface 377

18.1	Architectural Description	377
	18.1.1 Analog Data Bus Interface	378
	18.1.2 Analog Comparator Bus Interface	378
	18.1.3 Analog Column Clock Generation	379
	18.1.3.1 Column Clock Synchronization.....	379
	18.1.4 Decimator and Incremental ADC Interface	379
	18.1.4.1 Decimator.....	379
	18.1.4.2 Incremental ADC	379
	18.1.5 Analog Modulator Interface (Mod Bits)	380
	18.1.6 Analog Synchronization Interface (Stalling)	381
18.2	PSoC Device Distinctions.....	381
18.3	Application Description	382
	18.3.1 SAR Hardware Acceleration	382
	18.3.1.1 Architectural Description	382
	18.3.1.2 Application Description	383
	18.3.1.3 SAR Timing.....	384
18.4	Register Definitions	386
	18.4.1 CMP_CR0 Register	386
	18.4.2 ASY_CR Register	387
	18.4.3 CMP_CR1 Register	388
	18.4.4 DEC_CR0 Register	388
	18.4.5 DEC_CR1 Register	388
	18.4.6 CLK_CR0 Register	390
	18.4.7 CLK_CR1 Register	390

18.4.8	AMD_CR0 Register	391
18.4.9	CMP_GO_EN Register	391
18.4.10	CMP_GO_EN1 Register	392
18.4.11	AMD_CR1 Register	392
18.4.12	ALT_CR0 Register	393
18.4.13	ALT_CR1 Register	393
18.4.14	CLK_CR2 Register	394
19.	Analog Array.....	395
19.1	Architectural Description	395
19.1.1	NMux Connections	396
19.1.2	PMux Connections.....	397
19.1.3	RBotMux Connections	398
19.1.4	AMux Connections	399
19.1.5	CMux Connections	400
19.1.6	BMux SC/SD Connections	401
19.1.7	Analog Comparator Bus	401
19.2	Temperature Sensing Capability	402
20.	Analog Input Configuration	403
20.1	Architectural Description	403
20.1.1	Four Column Analog Input Configuration	404
20.1.2	Two Column Analog Input Configuration	405
20.1.3	One Column Analog Input Configuration	407
20.2	Register Definitions	408
20.2.1	AMX_IN Register	408
20.2.2	ABF_CR0 Register	409
21.	Analog Reference	411
21.1	Architectural Description	411
21.2	Register Definitions	412
21.2.1	ARF_CR Register	412
22.	Continuous Time PSoC Block	415
22.1	Architectural Description	415
22.2	Register Definitions	417
22.2.1	ACBxxCR3 Register	417
22.2.2	ACBxxCR0 Register	419
22.2.3	ACBxxCR1 Register	419
22.2.4	ACBxxCR2 Register	420
23.	Switched Capacitor PSoC Block	421
23.1	Architectural Description	421
23.2	Application Description.....	423
23.3	Register Definitions	424
23.3.1	ASCxxCR0 Register	425
23.3.2	ASCxxCR1 Register	426
23.3.3	ASCxxCR2 Register	426
23.3.4	ASCxxCR3 Register	427
23.3.5	ASDxxCR0 Register	428
23.3.6	ASDxxCR1 Register	429
23.3.7	ASDxxCR2 Register	429
23.3.8	ASDxxCR3 Register	430

24. Two Column Limited Analog System.....	431
24.1 Architectural Description	431
24.1.1 Analog Interface	431
24.1.1.1 Analog Comparator Bus Interface	432
24.1.1.2 Analog Column Clock Generation	432
24.1.1.3 Single Slope ADC	433
24.1.1.4 PWM ADC Interface.....	434
24.1.1.5 Analog Modulator Interface (Mod Bits)	434
24.1.1.6 Sample and Hold Feature	434
24.1.2 Analog Array	435
24.1.2.1 NMux Connections	436
24.1.2.2 PMux Connections.....	437
24.1.2.3 Temperature Sensing Capability	437
24.1.3 Analog Input Configuration	437
24.1.4 Analog Reference	441
24.1.5 Continuous Time PSoC Block	441
24.1.6 Switched Capacitor PSoC Block	442
24.1.6.1 Application Description for the SC Block	442
24.2 PSoC Device Distinctions.....	442
24.3 Register Definitions	443
24.3.1 Summary Table for 2 Column Limited Analog System Registers	443
24.3.2 Analog Interface Registers.....	444
24.3.3 Analog Input Configuration Registers	449
24.3.4 Continuous Time PSoC Block Registers.....	450
24.3.5 Switched Capacitor PSoC Block Register.....	451
 Section F: System Resources	 453
Top Level System Resources Architecture	453
Interpreting the System Resources Documentation	454
System Resources Register Summary	455
 25. Digital Clocks.....	 459
25.1 Architectural Description.....	459
25.1.1 Internal Main Oscillator	459
25.1.2 Internal Low Speed Oscillator	459
25.1.3 32.768 kHz Crystal Oscillator.....	461
25.1.4 External Clock	461
25.1.4.1 Clock Doubler	461
25.1.4.2 Switch Operation.....	461
25.2 PSoC Device Distinctions.....	462
25.3 Register Definitions	463
25.3.1 INT_CLR0 Register	463
25.3.2 INT_MSK0 Register	463
25.3.3 OSC_GO_EN Register	464
25.3.4 OSC_CR4 Register	464
25.3.5 OSC_CR3 Register	465
25.3.6 OSC_CR0 Register	466
25.3.7 OSC_CR1 Register	467
25.3.8 OSC_CR2 Register	468
 26. Multiply Accumulate (MAC).....	 469
26.1 Architectural Description	469
26.2 Application Description	470
26.2.1 Multiplication with No Accumulation	470
26.2.2 Accumulation After Multiplication	470

26.3	Register Definitions	470
26.3.1	MULx_X Register	471
26.3.2	MULx_Y Register	471
26.3.3	MULx_DH Register	471
26.3.4	MULx_DL Register	472
26.3.5	MACx_X/ACCx_DR1 Register	472
26.3.6	MACx_Y/ACCx_DR0 Register	472
26.3.7	MACx_CL0/ACCx_DR3 Register	473
26.3.8	MACx_CL1/ACCx_DR2 Register	473
27.	Decimator	475
27.1	Architectural Description	475
27.1.1	Type 1 Decimator Block	475
27.1.2	Type 2 Decimator Block	477
27.1.3	Decimator Scenarios	478
27.2	PSoC Device Distinctions.....	478
27.3	Register Definitions	479
27.3.1	DEC_DH Register	479
27.3.2	DEC_DL Register	479
27.3.3	DEC_CR0 Register	480
27.3.4	DEC_CR1 Register	480
27.3.5	DEC_CR2 Register	481
28.	I2C	483
28.1	Architectural Description	483
28.1.1	Basic I2C Data Transfer.....	483
28.2	Application Description.....	484
28.2.1	Slave Operation	484
28.2.2	Master Operation	485
28.3	Register Definitions	486
28.3.1	I2C_CFG Register	486
28.3.2	I2C_SCR Register	488
28.3.3	I2C_DR Register	490
28.3.4	I2C_MSCR Register	491
28.4	Timing Diagrams	493
28.4.1	Clock Generation	493
28.4.2	Basic Input/Output Timing.....	493
28.4.3	Status Timing	494
28.4.4	Master Start Timing.....	495
28.4.5	Master Restart Timing.....	496
28.4.6	Master Stop Timing	496
28.4.7	Master/Slave Stall Timing	497
28.4.8	Master Lost Arbitration Timing	497
28.4.9	Master Clock Synchronization	498
29.	Internal Voltage Reference	499
29.1	Architectural Description	499
29.2	PSoC Device Distinctions.....	499
29.3	Register Definitions	499
29.3.1	BDG_TR Register	500
30.	System Resets	501
30.1	Architectural Description	501
30.2	Pin Behavior During Reset	501
30.2.1	GPIO Behavior on Power Up.....	501

30.2.2	GPIO Behavior on External Reset	502
30.3	Register Definitions	503
30.3.1	CPU_SCR1 Register	503
30.3.2	CPU_SCR0 Register	504
30.4	Timing Diagrams	505
30.4.1	Power On Reset	505
30.4.2	External Reset	505
30.4.3	Watchdog Timer Reset	505
30.4.4	Reset Details.....	507
30.5	Power Consumption	507
31.	Switch Mode Pump (SMP).....	509
31.1	Architectural Description.....	509
31.2	Application Description	510
31.2.1	Component Value Selection.....	510
31.3	Register Definitions	511
31.3.1	VLT_CR Register	511
32.	POR and LVD	513
32.1	Architectural Description.....	513
32.2	PSoC Device Distinctions.....	513
32.3	Register Definitions	513
32.3.1	VLT_CR Register	514
32.3.2	VLT_CMP Register	515
33.	IO Analog Multiplexer	517
33.1	Architectural Description	517
33.2	PSoC Device Distinctions.....	518
33.3	Application Description	518
33.3.1	Capacitive Sensing	518
33.3.2	Chip-Wide Analog Input	519
33.3.3	Crosspoint Switch	519
33.3.4	Charging Current.....	520
33.4	Register Definitions	521
33.4.1	AMUX_CFG Register	521
33.4.2	DAC_D Register	521
33.4.3	AMUX_CLK Register	522
33.4.4	MUX_CRx Registers	522
33.4.5	DAC_CR Register	522
34.	Full-Speed USB.....	523
34.1	Architectural Description	523
34.2	Application Description	523
34.2.1	USB SIE.....	523
34.2.2	USB SRAM	524
34.2.2.1	PSoC Memory Arbiter.....	524
34.2.3	Oscillator Lock.....	526
34.2.4	Transceiver	526
34.2.5	Regulator.....	526
34.2.6	Interrupts.....	527
34.2.7	Reset.....	527
34.2.8	USB Suspend Mode.....	527
34.2.9	Sample Schematic for USB.....	528
34.3	Register Definitions	529
34.3.1	PMAx_DR Register	529

34.3.2	USB_SOFx Register	529
34.3.3	USB_CR0 Register	530
34.3.4	USBIO_CR0 Register	530
34.3.5	USBIO_CR1 Register	531
34.3.6	EPx_CNT1 Register	531
34.3.7	EPx_CNT Register	532
34.3.8	EP0_CR Register	533
34.3.9	EP0_CNT Register	534
34.3.10	EP0_DRx Register	534
34.3.11	PMAx_WA Register	535
34.3.12	PMAx_RA Register	535
34.3.13	USB_CR1 Register	536
34.3.14	EPx_CR0 Register	536
34.3.15	IMO_TR1 Register	537
34.3.16	IMO_TR2 Register	537
35.	nvSRAM	539
35.1	Architectural Description	539
35.2	Application Description	539
35.2.1	SRAM Read and SRAM Write	539
35.2.1.1	AutoStore Operation	539
35.2.1.2	Hardware RECALL (Power Up)	540
35.2.1.3	Software STORE	540
35.2.1.4	Software RECALL	540
35.2.1.5	Preventing AutoStore	540
Section G:	Glossary	541
Index		557

Section A: Overview



The PSoC® family consists of many programmable systems-on-chip with on-chip controller devices. As described in this technical reference manual (TRM), a PSoC device includes configurable blocks of analog circuits and **digital logic**, as well as programmable interconnect. This architecture allows the user to create customized peripheral configurations, to match the requirements of each individual application. Additionally, a fast CPU, Flash program memory, SRAM data memory, and configurable input/output (IO) are included in a range of pinouts.

This document is a technical reference manual for all PSoCs with a base part number of CY8C2xxxx, except for the CY8C25122 and CY8C26xxx PSoC devices. It also applies to CY7C64215, CY7C603xx, CY8CNP1xx, and CYWUSB6953. To use this manual effectively, you must know how many digital rows and how many analog columns your PSoC device has (see the PSoC Device Characteristics table on page 22) and be aware of your PSoC device's distinctions (see the PSoC Device Distinctions on page 23). For the most up-to-date Ordering, Pinout, Packaging, or Electrical Specification information, refer to the individual PSoC device's data sheet. For the most current technical reference manual information, refer to the addendum. To obtain the newest product documentation, go to the Cypress website at <http://www.cypress.com/psoc>. This section encompasses the following chapter:

- [Pin Information on page 29](#)

Document Organization

This manual is organized into sections and chapters, according to **PSoC** functionality. Each section begins with documentation interpretation, a top level architectural explanation, PSoC device distinctions (if relevant), and a register summary (if applicable). Most chapters within the sections have an introduction, an architectural/application description, PSoC device distinctions (if relevant), register definitions, and timing diagrams. The sections are as follows:

- **Overview** – Presents the PSoC top level architecture, PSoC device characteristics and distinctions, how to get started with helpful information, and document history and conventions. The PSoC device **pinouts** are detailed in the [Pin Information chapter on page 29](#).
- **PSoC Core** – Describes the heart of the PSoC device in various chapters, beginning with an architectural overview and a summary list of registers pertaining to the PSoC core. See “[PSoC Core](#)” on page 59.
- **Register Reference** – Lists all PSoC device registers in [Register Mapping Tables, on page 141](#), and presents bit-level detail of each PSoC register in its own [Register Details chapter on page 147](#). Where applicable, detailed register descriptions are also located in each chapter.
- **Digital System** – Describes the configurable PSoC digital system in various chapters, beginning with an architectural overview and a summary list of registers pertaining to the digital system. See the “[Digital System](#)” on page 307.
- **Analog System** – Describes the configurable PSoC analog system in various chapters, beginning with an architectural overview and a summary list of registers pertaining to the analog system. See the “[Analog System](#)” on page 371.
- **System Resources** – Presents additional PSoC system resources, depending on the PSoC device, beginning with an overview and a summary list of registers pertaining to system resources. See “[System Resources](#)” on page 453.
- **Glossary** – Defines the specialized terminology used in this manual. Glossary terms are presented in **bold, italic font** throughout this manual. See the “[Glossary](#)” on page 541.
- **Index** – Lists the location of key topics and elements that constitute and empower the PSoC device. See the “[Index](#)” on page 557.

Top Level Architecture

The PSoC block diagram on the next page illustrates the top level architecture of the family of PSoC devices. Each major grouping in the diagram is covered in this manual in its own section: PSoC Core, Digital System, Analog System, and the System Resources. Banding these four main areas together is the communication network of the system **bus**.

PSoC Core

The PSoC Core is a powerful engine that supports a rich instruction set. It encompasses the **SRAM** for data storage, an **interrupt** controller for easy program execution to new addresses, sleep and watchdog timers, and multiple **clock** sources that include the phase locked loop (PLL), IMO (internal main oscillator), ILO (internal low speed oscillator), and ECO (32.768 kHz external crystal oscillator) for precision, programmable clocking. The clocks, together with programmable clock dividers (as a System Resource), provide the flexibility to integrate almost any timing requirement into the PSoC device.

The CPU core, called the M8C, is a powerful processor with speeds up to 24 MHz. The M8C is a four MIPS 8-bit Harvard architecture microprocessor. Within the CPU core are the **SRAM** and **Flash** memory components that provide flexible programming. The smallest PSoC devices have a slightly different analog configuration.

PSoC GPIOs provide connection to the CPU, digital and analog resources of the device. Each pin's drive mode may be selected from eight options, allowing great flexibility in external interfacing. Every pin also has the capability to generate a system interrupt on high level, low level, and change from last read.

Digital System

The Digital System is composed of digital rows in a block **array**, and the Global, Array, and Row Digital Interconnects (GDI, ADI, and RDI, respectively). Digital blocks are provided in rows of four, where the number of blocks varies by PSoC device (see “PSoC Device Characteristics” on page 22). This allows you the optimum choice of system resources for your application.

The digital blocks can be connected to any GPIO through a series of global buses that can route any signal to any pin. The buses also allow for signal multiplexing and for performing logic operations. This configurability frees your designs from the constraints of a fixed peripheral controller.

Analog System

The Analog System is composed of analog columns in a block array, analog references, analog **input** muxing, and analog drivers. The analog system block is composed of up to four analog columns with up to 12 analog blocks, depending on the characteristics of your PSoC device (see “PSoC Device Characteristics” on page 22). Each configurable block is comprised of an opamp circuit allowing the creation of complex analog signal flows.

Each analog column contains one Continuous Time (CT) block, Type B (ACB); one Switched Capacitor (SC) block, Type C (ASC); and one Switched Capacitor block, Type D (ASD). The analog columns in the CY8C21x34, CY8C21x23, CY7C603xx, and CYWUSB6953 PSoC devices each contain one Type E CT block (ACE) and one Type E SC block (ASE), as described in the [Two Column Limited Analog System](#) chapter on page 431.

System Resources

The System Resources provide additional PSoC capability, depending on the features of your PSoC device (see the table titled “Availability of System Resources for PSoC Devices” on page 22). These system resources include:

- Digital clocks to increase the flexibility of the PSoC **mixed-signal** arrays.
- Up to two multiply accumulates (MACs) that provide fast 8-bit multipliers or fast 8-bit multipliers with 32-bit accumulate
- Up to two decimators for digital **signal** processing applications
- **I2C** functionality for implementing either I2C slave or master
- Up to 256KBytes of SecureStore nvSRAM
- An internal voltage reference that provides an absolute value of 1.3V to a variety of PSoC subsystems
- A switch mode pump (SMP) that generates normal operating voltages off a single battery cell
- An enhanced analog multiplexer (mux) that allows every I/O pin to connect to a common internal analog mux bus
- A five endpoint full speed (12 Mb/s) USB device
- Various system resets supported by the M8C

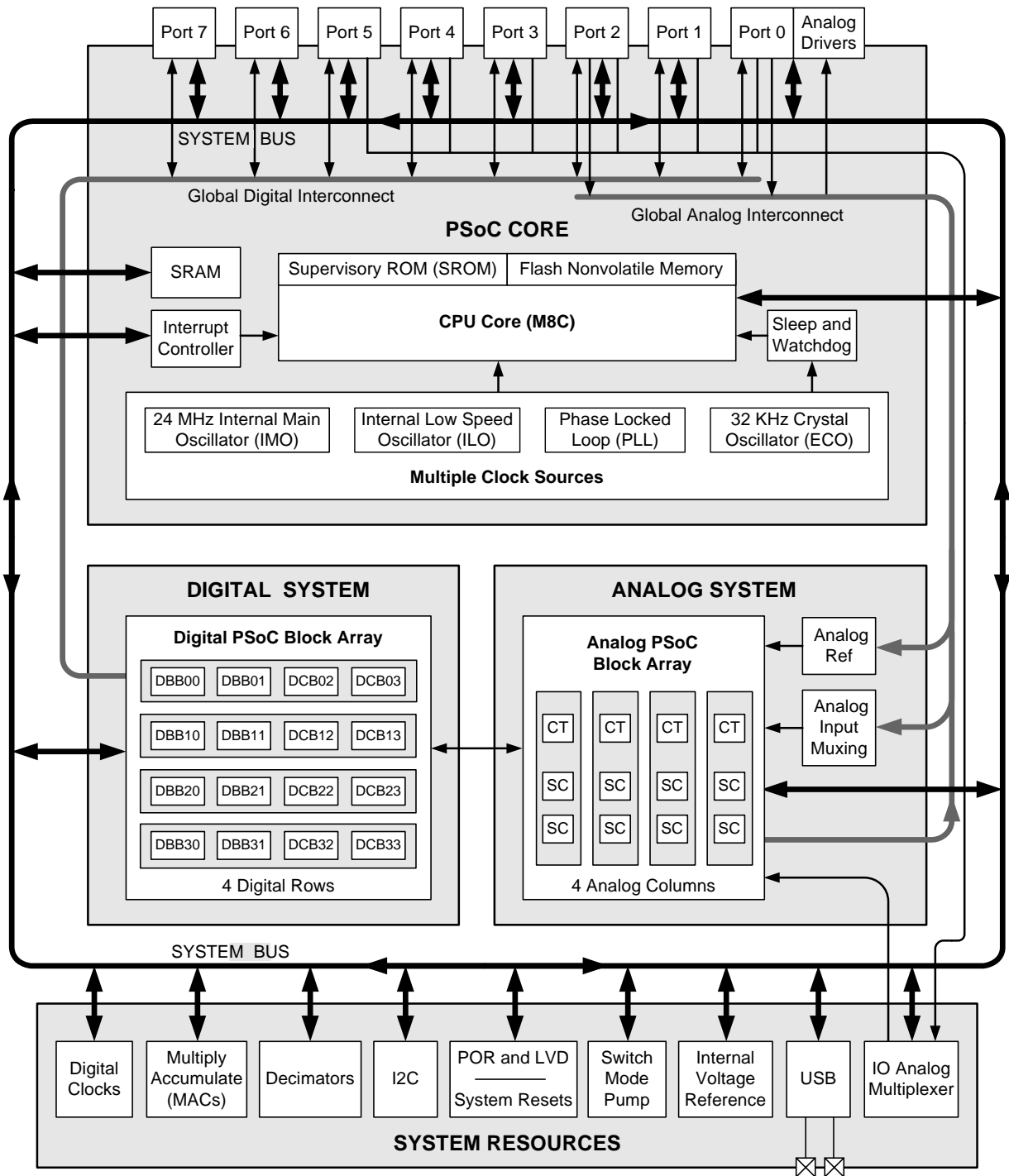

PSoC Top Level Block Diagram

PSoC Device Characteristics

There are many chip groups in the PSoC Programmable System-on-Chip Family. Besides differentiating these groups by way of PSoC part numbers, each PSoC group is easily distinguished by the unique number of digital rows and analog columns it has. This unique characteristic is the foundation for how this manual presents information.

The **digital** system can have 4, 2, or 1 digital rows. The **analog** system can have 4, 2, or 1 analog columns. Each PSoC device has a unique combination of digital rows and analog columns. The following table lists the resources available for specific PSoC device groups. Remember the particular PSoC device characteristics when referencing its functionality in this manual.

PSoC Device Characteristics

PSoC Device Group	Digital IO (max)	Digital Rows	Digital Blocks	Analog Inputs	Analog Outputs	Analog Columns	Analog Blocks	Amount of SRAM	Amount of Flash
CY8C29x66 CY8CPLC20 CY8CLED16P01	64	4	16	12	4	4	12	2 KB	32 KB
CY8C27x43	44	2	8	12	4	4	12	256 Bytes	16 KB
CY8C24x94	50	1	4	48	2	2	6	1 KB	16 KB
CY8C24x23	24	1	4	12	2	2	6	256 Bytes	4 KB
CY8C24x23A	24	1	4	12	2	2	6	256 Bytes	4 KB
CY8C22x13	16	1	4	8	1	1	3	256 Bytes	2 KB
CY8C21x34	28	1	4	28	0	2	4*	512 Bytes	8 KB
CY8C21x23	16	1	4	8	0	2	4*	256 Bytes	4 KB
CY7C64215	50	1	4	48	2	2	6	1 KB	16 KB
CY7C603xx	28	1	4	28	0	2	4*	512 Bytes	8 KB
CYWUSB6953	28	1	4	28	0	2	4*	512 Bytes	8 KB
CY8CNP1xx	33	4	16	12	4	4	12	2 KB	32 KB

* Limited analog functionality.

The following table lists the resources available for specific PSoC device groups. The check mark or appropriate information denotes that a system resource is available for the PSoC device. Blank fields denote that the system resource is not available. Note that the CY8C21x34, CY7C603xx, and CYWUSB6952 are the only PSoC devices that have the IO Analog Multiplexer system resource and the CY8C24x94 and CY7C64215 are the only PSoC devices that have the USB system resource. These resources are detailed in the section titled “System Resources” on page 453.

Availability of System Resources for PSoC Devices

PSoC Part Number	USB	Switch Mode Pump	Digital Clocks	I2C	Internal Voltage Ref.	POR and LVD	System Resets	Decimator*	Multiply Accumulate	nvSRAM
CY8C29x66		✓	✓	✓	✓	✓	✓	T2	2	
CY8C27x43		✓	✓	✓	✓	✓	✓	T1	1	
CY8C24x94 **	✓		✓	✓	✓	✓	✓	T2	2	
CY8C24x23		✓	✓	✓	✓	✓	✓	T1	1	
CY8C24x23A		✓	✓	✓	✓	✓	✓	T1	1	
CY8C22x13			✓	✓	✓	✓	✓	T1	0	
CY8C21x34 **		✓	✓	✓	✓	✓	✓		0	
CY8C21x23		✓	✓	✓	✓	✓	✓		0	
CY7C64215 **	✓		✓	✓	✓	✓	✓	T2	2	
CY7C603xx **		✓	✓	✓	✓	✓	✓		0	
CYWUSB6953 **		✓	✓	✓	✓	✓	✓		0	
CY8CNP1xx		✓	✓	✓	✓	✓	✓	T2	2	256 kbytes

* Decimator types: T1 = Type 1. T2 = Type 2.

** The only PSoC devices that have the IO Analog Multiplexer system resource or USB system resource.

PSoC Device Distinctions

The PSoC Programmable System-on-Chip device distinctions are listed in the table below and in each chapter section where it is appropriate. The PSoC device distinctions are significant exceptions or differences between PSoC groups and devices. They represent a unique difference from the information otherwise presented in this manual which encompasses all PSoC devices.

PSoC Device Distinctions

Device Distinctions	Devices Affected	Described in Chapter
Analog Blocks in these PSoC devices are distinct.	CY8C21x34 CY8C21x23 CY7C603xx CYWUSB6953	Two Column Limited Analog System chapter on page 431.
BLOCKID value of '0' will cause all available Flash to be checksummed. In all other PSoC devices, a BLOCKID value of '0' will checksum 256 blocks.	CY8C21x34 CY8C21x23 CY7C603xx CYWUSB6953	Supervisory ROM (SROM) chapter on page 73.
GPIO Pins: The CY8C24x94, CY8C21x34, CY7C64215, CY7C603xx, and CYWUSB6953 PSoC devices differ from the other PSoC devices in that GPIO pins can connect to the internal analog bus. The CY8C24x94 and CY7C64215 contain the additional capability to optionally split the analog bus into two separate sections. In the CY8C21x34, CY7C603xx, and CYWUSB6953 all GPIO pins are enabled for this connection. In the CY8C24x94 and CY7C64215 all pins in Ports 0 through 5 are enabled for connection to the analog bus.	CY8C21x34 CY8C24x94 CY7C64215 CY7C603xx CYWUSB6953	IO Analog Multiplexer chapter on page 517.
Low Power Oscillator Capability. The slow IMO (SLIMO) bit is available to enable SYSCLK operation at 6 MHz and 12 MHz, instead of only 24 MHz. The SLIMO bit is located in the CPU_SCR1 register on page 251.	CY8CPLC20 CY8CLED16P01 CY8C29x66 CY8C24x23A CY8C21x34 CY8C21x23 CY7C603xx CYWUSB6953 CY8CNP1xx	Internal Main Oscillator (IMO) chapter on page 113.
POR and LVD Trip Levels. The lowest POR level is set for 2.4V operation; the next lowest is set for 3.0V operation (instead of 3.0V or 4.5V operation).	CY8C24x23A CY8C21x34 CY8C21x23 CY7C603xx CYWUSB6953	POR and LVD chapter on page 513 and PSoC device data sheets.
Register Distinction: BDG_TR register on page 300 is a read and write register for all PSoC devices with one exception: The CY8C27x43 PSoC device cannot read the BDG_TR register.	CY8C27x43	Internal Voltage Reference chapter on page 499.
Register Distinction: CPU_SCR1 register on page 251 bit 4 (Slow IMO mode) is reserved.	CY8C27x43 CY8C24x23 CY8C22x13	Internal Main Oscillator (IMO) chapter on page 113.
Register Distinction: CPU_SCR1 register on page 251 bits 3 and 2 (ECO EXW and ECO EX, respectively) cannot be used.	CY8C27x43 Silicon Rev. A CY8C24x23 CY8C22x13	External Crystal Oscillator (ECO) chapter on page 119.
Register Distinction: DEC_CR1 register on page 247 only digital blocks DBB01, DCB02, DBB11, and DCB12 are valid.	CY8C27x43 Silicon Rev. A	Row Digital Interconnect (RDI) chapter on page 327 and Digital Clocks chapter on page 459.
Register Distinction: DEC_CR1 register on page 247 bit 7 (ECNT) is only available in devices with a type 1 decimator.	CY8C27x43 CY8C24x23 CY8C24x23A CY8C22x13	Analog Interface chapter on page 377 and Decimator chapter on page 475.
Register Distinction: CMP_CR1 register on page 183 bits 1 and 0 (CLK1X[1] and CLK1X[0]) are only available for the CY8C24x94 and CY7C64215 PSoC devices.	All devices except the CY8C24x94 and CY7C64215 CY8CNP1xx	Analog Interface chapter on page 377.
Register Distinction: DEC_CR1 register on page 247 bit 7 (ECNT) is reserved in devices with a type 2 decimator.	CY8CPLC20 CY8CLED16P01 CY8C29x66	Analog Interface chapter on page 377 and Decimator chapter on page 475.
Register Distinction: OSC_GO_EN register on page 288 bit 7 is reserved.	CY8C27x43 CY8C24x23 CY8C22x13	Digital Clocks chapter on page 459.
Register Distinction: OSC_GO_EN register on page 288 bits 6, 5, and 4 are reserved.	CY8C27x43	Digital Clocks chapter on page 459.

PSoC Device Distinctions (*continued*)

Device Distinctions	Devices Affected	Described in Chapter
Register Distinction: CMP_GO_EN register on page 271 and the CMP_GO_EN1 register on page 272, which allow connection of analog interface signals to the global bus, are only available in the CY8C24x94 and CY7C64215 PSoC devices, with the exception that the CMP_GO_EN register is also available to devices that have two column limited functionality such as the CY8C21x34, CY8C21x23, CY7C603xx, and CYWUSB6953 PSoC devices.	CY8C24x94 CY8C21x34 CY8C21x23 CY7C64215 CY7C603xx CYWUSB6953	Analog Interface chapter on page 377 and Two Column Limited Analog System chapter on page 431.
Temperature Sensing: The temperature sensor input (V_{TEMP}) is connected through the ACE01 PMux. There is no special ground reference for the signal.	CY8C21x34 CY8C21x23 CY7C603xx CYWUSB6953	Two Column Limited Analog System chapter on page 431.
VC3 based control for analog-to-digital conversion is unique to these PSoC devices.	CY8C21x34 CY8C21x23 CY7C603xx CYWUSB6953	Two Column Limited Analog System chapter on page 431.

Getting Started

The quickest path to understanding PSoC is by reading the PSoC device's data sheet and using the *PSoC Designer Integrated Development Environment (IDE)*. This manual is useful for understanding the details of the PSoC integrated circuit.

Important Note For the most up-to-date Ordering, Packaging, or Electrical Specification information, refer to the individual PSoC device's data sheet or go to <http://www.cypress.com/psoc>.

Support

Free support for PSoC products is available online at <http://www.cypress.com>. Resources include Training Seminars, Discussion Forums, Application Notes, PSoC Consultants, TightLink Technical Support Email/Knowledge Base, and Application Support Technicians.

Technical Support can be reached at <http://www.cypress.com/support> or can be contacted by phone at: 1.800.541.4736.

Product Upgrades

Cypress provides scheduled upgrades and version enhancements for PSoC Designer free of charge. You can order the upgrades from your distributor on CD-ROM or download them directly from <http://www.cypress.com> under Software. Also provided are critical updates to system documentation under Documentation.

Development Kits

Development Kits are available from the following distributors: Digi-Key, Avnet, Arrow, and Future. The Cypress Online Store contains development kits, **C** compilers, and all accessories for PSoC development. Go to the Cypress Online Store website at <http://www.cypress.com/shop/>, and click PSoC® Programmable System-on-Chip to view a current list of available items.

Document History

This section serves as a chronicle of the *PSoC Programmable System-on-Chip Technical Reference Manual*.

PSoC Technical Reference Manual History

Version/ Release Date	Originator	Description of Change
Version 1.00 May 17, 2004	SFV	First release of the <i>PSoC Mixed-Signal Array Technical Reference Manual</i> . This release encompasses the following PSoC devices: CY8C29x66, CY8C27x66, CY8C27x43, CY8C24x23, and CY8C22x13.
Version 1.10 August 20, 2004	SFV	This release encompasses the new CY8C21x34, CY8C21x23, CY7C603xx, and CYWUSB6953 PSoC devices, along with information on the low-voltage CY8C24x23A PSoC device. New chapters added to this manual are the Two Column Limited Analog System chapter located in the Analog System section and the IO Analog Multiplexer chapter located in the System Resources section. The CY8C27x66 PSoC device is no longer being offered and all references to the device were deleted.
Version 1.11 December 7, 2004	SFV	This interim release includes small changes and additions made to the 1.10 release. It does not include any new PSoC devices.
Version 1.20 February 4, 2005	SFV	This release encompasses the new CY8C24x94 USB PSoC device. The new chapter added to this manual is the Full-Speed USB chapter and is located in the System Resources section.
Version 1.21 May 3, 2005	SFV	This interim release includes small changes made to the 1.20 release. Changes include new information for the 56-pin part pinout, SPI timing text correction, a new register named AMUX_CLK, additional text to the CPU_SCR1 register, and a footnote in the "Flash Tables with Assigned Values in Flash Bank 0" table.
Version 1.22 July 29, 2005	SFV	This interim release includes small changes and additions made to the 1.21 release. POR and XRES information has been added to the System Resets chapter. It does not include any new PSoC devices.
Version 2.00 September 26, 2005	CKF	This release includes minor changes to various sections throughout the TRM; added CY7C64215, CY7C603xx, and CYWUSB6953.
Version 2.01 March 1, 2006	SFV	This release includes minor changes throughout the manual.
Version 2.10 April 13, 2006	SFV	This release includes new OCD part pinouts and the addition of 100-ball VFBGA part pinouts for the CY8C24x94. Also, the clocking section in the SRAM chapter has been revised.
Version 2.20 September 21, 2006	SFV	This interim release includes small edits/changes throughout the TRM.
Revision ** July 17, 2007	SFV	Began using Cypress document numbering system, starting with revision **. Added new copyright/disclaimer information. Corrected small errors throughout.
Revision *A September 8, 2008	HMT	Update copyright page. Update hyperlink color to CY blue. Update PSoC to registered trademark in text and figures. Resolve unrecognizable font issue in all files. Update CDTs 28275, 28343.
Revision *B November 21, 2008	DSG	Added CY8CPLC20 and CY8CLED16P01 part numbers. Changed "mixed-signal array" to "programmable system-on-chip."
Revision *C December 9, 2008	VED	This release contains the new CY8CNP1xx PSoC NV device. A new chapter on nvSRAM is added to the manual and is located in the System Resources section.
Revision *D June 12, 2009	AESA	This release includes minor changes throughout the manual.

Documentation Conventions

There are only four distinguishing font types used in this manual, besides those found in the headings.

- The first is the use of *italics* when referencing a document title or file name.
- The second is the use of ***bold italics*** when referencing a term described in the Glossary of this manual.
- The third is the use of Times New Roman font, distinguishing equation examples.
- The fourth is the use of Courier New font, distinguishing code examples.

Register Conventions

The following table lists the register conventions that are specific to this manual. A more detailed set of register conventions is located in the [Register Details chapter on page 147](#).

Register Conventions

Convention	Example	Description
'x' in a register name	ACBxxCR1	Multiple instances/address ranges of the same register
R	R : 00	Read register or bit(s)
W	W : 00	Write register or bit(s)
L	RL : 00	Logical register or bit(s)
C	RC : 00	Clearable register or bit(s)
00	RW : 00	Reset value is 0x00 or 00h
XX	RW : XX	Register is not reset
0,	0,04h	Register is in bank 0
1,	1,23h	Register is in bank 1
x,	x,F7h	Register exists in register bank 0 and register bank 1
Empty, grayed-out table cell		Reserved bit or group of bits, unless otherwise stated

Numeric Naming

Hexadecimal numbers are represented with all letters in uppercase with an appended lowercase 'h' (for example, '14h' or '3Ah') and **hexadecimal** numbers may also be represented by a '0x' prefix, the **C** coding convention. Binary numbers have an appended lowercase 'b' (for example, 01010100b' or '01000011b'). Numbers not indicated by an 'h' or 'b' are **decimal**.

Units of Measure

The following table lists the units of measure used in this manual.

Units of Measure

Symbol	Unit of Measure
dB	decibels
Hz	hertz
k	kilo, 1000
K	2 ¹⁰ , 1024
KB	1024 bytes
Kbit	1024 bits
kHz	kilohertz (32.000)
MHz	megahertz
μA	microampere
μF	microfarad
μs	microsecond
μV	microvolts
mA	milliampere
ms	millisecond
mV	millivolts
ns	nanosecond
pF	picofarad
ppm	parts per million
V	volts

Acronyms

The following table lists the acronyms that are used in this manual.

Acronyms

Acronym	Description
ABUS	analog output bus
AC	alternating current
ADC	analog-to-digital converter
API	Application Programming Interface
BC	broadcast clock
BR	bit rate
BRA	bus request acknowledge
BRQ	bus request
CBUS	comparator bus
CI	carry in
CMP	compare
CO	carry out
CPU	central processing unit
CRC	cyclic redundancy check
CT	continuous time
DAC	digital-to-analog converter
DC	direct current
DI	digital or data input
DMA	direct memory access
DO	digital or data output
ECO	external crystal oscillator
FB	feedback
GIE	global interrupt enable
GPIO	general purpose IO
ICE	in-circuit emulator
IDE	integrated development environment
ILO	internal low speed oscillator
IMO	internal main oscillator
IO	input/output
IOR	IO read
IOW	IO write
IPOR	imprecise power on reset
IRQ	interrupt request
ISR	interrupt service routine
ISSP	in system serial programming
IVR	interrupt vector read
LFSR	linear feedback shift register
LRb	last received bit
LRB	last received byte
LSb	least significant bit
LSB	least significant byte
LUT	look-up table
MISO	master-in-slave-out
MOSI	master-out-slave-in
MSb	most significant bit
MSB	most significant byte
nvSRAM	nonvolatile static random access memory

Acronyms (continued)

Acronym	Description
PC	program counter
PCH	program counter high
PCL	program counter low
PD	power down
PMA	PSoC® memory arbiter
POR	power on reset
PPOR	precision power on reset
PRS	pseudo random sequence
PSoC®	Programmable System-on-Chip™
PSSDC	power system sleep duty cycle
PWM	pulse width modulator
RAM	random access memory
RETI	return from interrupt
RI	row input
RO	row output
ROM	read only memory
RW	read/write
SAR	successive approximation register
SC	switched capacitor
SIE	serial interface engine
SE0	single-ended zero
SOF	start of frame
SP	stack pointer
SPI	serial peripheral interconnect
SPIM	serial peripheral interconnect master
SPIS	serial peripheral interconnect slave
SRAM	static random access memory
SROM	supervisory read only memory
SSADC	single slope ADC
SSC	supervisory system call
TC	terminal count
USB	universal serial bus
WDT	watchdog timer
WDR	watchdog reset
XRES	external reset

1. Pin Information



This chapter lists, describes, and illustrates all PSoC device pins and pinout configurations. For up-to-date Ordering, Pinout, and Packaging information, refer to the individual PSoC device's data sheet or go to <http://www.cypress.com/psoc>.

1.1 Pinouts

The PSoC devices are available in a variety of packages. Refer to the following information for details on individual **devices**. Every **port** pin (labeled with a "P"), except for **Vss**, **Vdd**, **SMP**, and **XRES** in the following tables and illustrations, is capable of Digital IO. Note that if a PSoC device pinout is different from what is listed in the All Devices column, the difference is listed in the individual PSoC device column and also illustrated to the right of the table.

1.1.1 8-Pin Part Pinouts

The 8-**pin** part is for the CY8C27143, CY8C24123, CY8C24123A, CY8C22113, and CY8C21123 PSoC devices.

Table 1-1. 8-Pin Part Pinout (PDIP, SOIC)

Pin No.	All Devices			Description	Only Devices CY8 –			
	Digital	Analog	Name		C27x43	C24x23/ C24x23A	C22x13	C21x23
1	IO	I	P0[5]	Analog column mux input and column output.	AO	AO	AO	
2	IO	I	P0[3]	Analog column mux input.	AO	AO		
3	IO		P1[1]*	Crystal (XTALin), I2C Serial Clock (SCL)				#
4	Power		Vss	Ground connection.				
5	IO		P1[0]*	Crystal (XTALout), I2C Serial Data (SDA)				#
6	IO	I	P0[2]	Analog column mux input.	AO			
7	IO	I	P0[4]	Analog column mux input.	AO			
8	Power		Vdd	Supply voltage.				

LEGEND A = Analog, I = Input, O = Output.
 # Crystal (XTALin and XTALout) is not available for the CY8C21123.
 * ISSP pin, which is not High Z at POR.

CY8C27143 PSoC Device

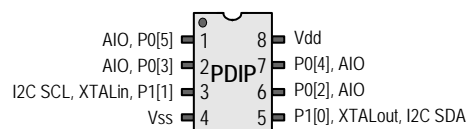

CY8C24123, and CY8C24123A PSoC Devices

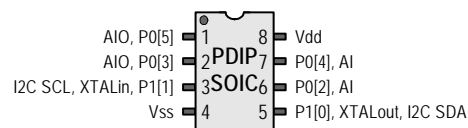

CY8C22113 PSoC Device

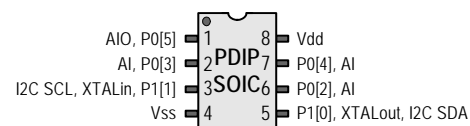

CY8C21123 PSoC Device

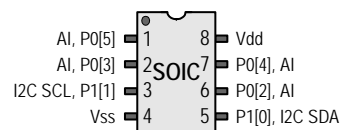

1.1.2 16-Pin Part Pinout

The 16-pin part is for the CY8C21234 and CY8C21223 PSoC devices. Note that analog mux input is only available for the CY8C21234 PSoC device.

Table 1-2. 16-Pin Part Pinout (SOIC)

Pin No.	Digital	Analog**	Name	Description
1	IO	I,M	P0[7]	Analog column mux input.
2	IO	I,M	P0[5]	Analog column mux input.
3	IO	I,M	P0[3]	Analog column mux input.
4	IO	I,M	P0[1]	Analog column mux input.
5	Power		SMP	Switch Mode Pump (SMP) connection to required external components.
6	Power		Vss	Ground connection.
7	IO	M	P1[1]*	I2C Serial Clock (SCL)
8	Power		Vss	Ground connection.
9	IO	M	P1[0]*	I2C Serial Data (SDA)
10	IO	M	P1[2]	
11	IO	M	P1[4]	Optional External Clock Input (EXTCLK)
12	IO	I,M	P0[0]	Analog column mux input.
13	IO	I,M	P0[2]	Analog column mux input.
14	IO	I,M	P0[4]	Analog column mux input.
15	IO	I,M	P0[6]	Analog column mux input.
16	Power		Vdd	Supply voltage.

LEGENDA = Analog, I = Input, O = Output, M = Analog Mux Input.

* ISSP pin, which is not High Z at POR.

** Analog Mux Input is only available for the CY8C21x34, CY7C603xx, and CYWUSB6953 PSoC devices.

CY8C21234 and CY8C21223 PSoC Devices

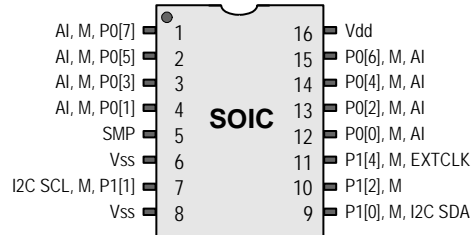

CY8C21223 PSoC Device

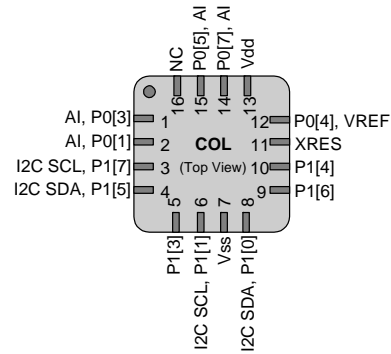

1.1.3 20-Pin Part Pinouts

The 20-pin part is for the CY8C27243, CY8C24223, CY8C24223A, CY8C22213, CY8C21334, and CY8C21323 PSoC devices. Note that analog mux input is only available for the CY8C21334 PSoC device.

Table 1-3. 20-Pin Part Pinout (PDIP, SSOP, SOIC)

Pin No.	All Devices				Only Devices CY8 –				
	Digital	Analog	Name	Description	C29x66	C27x43	C24x23	C22x13	C21x34**/ C21x23
1	IO	I	P0[7]	Analog column mux input.					M
2	IO	I	P0[5]	Analog column mux input and column output.	AO	AO	AO	AO	M
3	IO	I	P0[3]	Analog column mux input.	AO	AO	AO		M
4	IO	I	P0[1]	Analog column mux input.					M
5	Power		SMP	Switch Mode Pump (SMP) connection to required external components.				Vss	Vss
6	IO		P1[7]	I2C Serial Clock (SCL).					M
7	IO		P1[5]	I2C Serial Data (SDA).					M
8	IO		P1[3]						M
9	IO		P1[1]*	Crystal (XTALin), I2C Serial Clock (SCL).					#M
10	Power		Vss	Ground connection.					
11	IO		P1[0]*	Crystal (XTALout), I2C Serial Data (SDA).					#M
12	IO		P1[2]						M
13	IO		P1[4]	Optional External Clock Input (EXTCLK).					M
14	IO		P1[6]						M
15	Input		XRES	Active high pin reset with internal pull down.					
16	IO	I	P0[0]	Analog column mux input.					M
17	IO	I	P0[2]	Analog column mux input.	AO	AO			M
18	IO	I	P0[4]	Analog column mux input.	AO	AO			M
19	IO	I	P0[6]	Analog column mux input.					M
20	Power		Vdd	Supply voltage.					

LEGEND A = Analog, I = Input, O = Output, M = Analog Mux Input.
 # Crystal (XTALin and XTALout) is not available for the CY8C21x34, CY8C21x23, CY7C603xx, or CYWUSB6953.
 * ISSP pin, which is not High Z at POR.
 ** Analog Mux Input is only available for the CY8C21x34, CY7C603xx, and CYWUSB6953 PSoC devices.

CY8C27243 PSoC Device

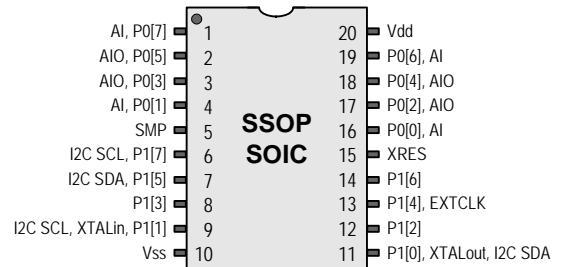

CY8C24223 and CY8C24223A PSoC Devices

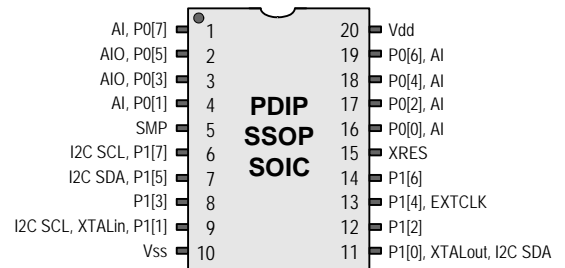

CY8C22213 PSoC Device

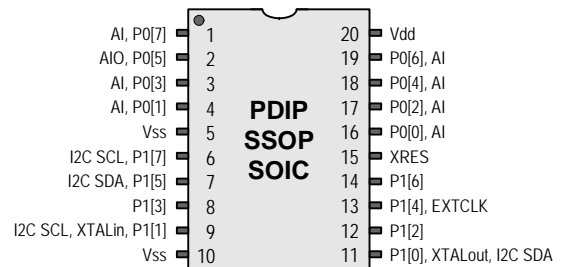

CY8C21334 and CY8C21323 PSoC Devices

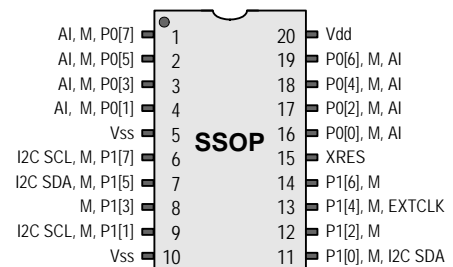

1.1.4 24-Pin Part Pinout

The 24-pin part is for the CY8C21323 PSoC device.

Table 1-4. 24-Pin Part Pinout (QFN**)

Pin No.	Digital	Analog	Name	Description
1	IO	I	P0[1]	Analog column mux input.
2	Power		SMP	Switch Mode Pump (SMP) connection to required external components.
3	Power		Vss	Ground connection.
4	IO		P1[7]	I2C Serial Clock (SCL).
5	IO		P1[5]	I2C Serial Data (SDA).
6	IO		P1[3]	
7	IO		P1[1]*	I2C Serial Clock (SCL).
8			NC	No internal connection.
9	Power		Vss	Ground connection.
10	IO		P1[0]*	I2C Serial Data (SDA).
11	IO		P1[2]	
12	IO		P1[4]	Optional External Clock Input (EXTCLK).
13	IO		P1[6]	
14	Input		XRES	Active high pin reset with internal pull down.
15			NC	No internal connection.
16	IO	I	P0[0]	Analog column mux input.
17	IO	I	P0[2]	Analog column mux input.
18	IO	I	P0[4]	Analog column mux input
19	IO	I	P0[6]	Analog column mux input.
20	Power		Vdd	Supply voltage.
21	Power		Vss	Ground connection.
22	IO	I	P0[7]	Analog column mux input.
23	IO	I	P0[5]	Analog column mux input.
24	IO	I	P0[3]	Analog column mux input.

LEGEND A = Analog, I = Input, O = Output, NC = No Connection.
 * ISSP pin, which is not High Z at POR.
 ** The QFN package has a center pad that must be connected to ground (Vss).

CY8C21323 PSoC Device

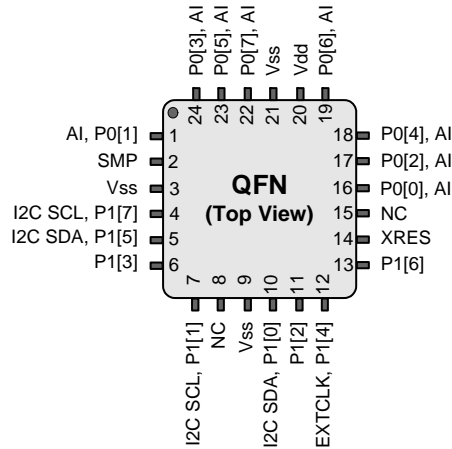

1.1.5 28-Pin Part Pinouts

The 28-pin part is for the CY8CPLC20, CY8CLE16P01, CY8C29466, CY8C27443, CY8C24423, CY8C24423A, CY8C21534, CY7C64215 (on next page) and CY7C60323 PSoC devices. Note that analog mux input is only available for the CY8C21434 PSoC device.

Table 1-5. 28-Pin Part Pinout (PDIP, SSOP, SOIC)

Pin No.	All Devices			Only Devices CY8				CY7C60323	
	Digital	Analog	Name	Description	C29x66	C27x43	C24x23		C21x34
1	IO	I	P0[7]	Analog column mux input.				M	M
2	IO	I	P0[5]	Analog column mux input and column output.	AO	AO	AO	M	M
3	IO	I	P0[3]	Analog column mux input and column output.	AO	AO	AO	M	M
4	IO	I	P0[1]	Analog column mux input.				M	M
5	IO		P2[7]					M	M
6	IO		P2[5]					M	M
7	IO	I	P2[3]	Direct switched capacitor block input.				M	M
8	IO	I	P2[1]	Direct switched capacitor block input.				M	M
9	Power		SMP	Switch Mode Pump (SMP) connection to required external components.				**	**
10	IO		P1[7]	I2C Serial Clock (SCL).				M	M
11	IO		P1[5]	I2C Serial Data (SDA).				M	M
12	IO		P1[3]					M	M
13	IO		P1[1]*	Crystal (XTALin), I2C Serial Clock (SCL).				#M	#M
14	Power		Vss	Ground connection.					
15	IO		P1[0]*	Crystal (XTALout), I2C Serial Data (SDA).				#M	#M
16	IO		P1[2]					M	M
17	IO		P1[4]	Optional External Clock Input (EXTCLK).				M	M
18	IO		P1[6]					M	M
19	Input		XRES	Active high pin reset with internal pull down.					
20	IO	I	P2[0]	Direct switched capacitor block input.				M	M
21	IO	I	P2[2]	Direct switched capacitor block input.				M	M
22	IO		P2[4]	External Analog Ground (AGND) input.				+M	+M
23	IO		P2[6]	External Voltage Reference (VRef) input.				+M	+M
24	IO	I	P0[0]	Analog column mux input.				M	M
25	IO	I	P0[2]	Analog column mux input.	AO	AO		M	M
26	IO	I	P0[4]	Analog column mux input.	AO	AO		M	M
27	IO	I	P0[6]	Analog column mux input.				M	M
28	Power		Vdd	Supply voltage.					

LEGEND A = Analog, I = Input, O = Output, M = Analog Mux Input.
 # Crystal (XTALin and XTALout) is not available for the CY8C21434.
 + External VRef and External AGND are not available for the CY8C21434 and CY7C60323.
 * ISSP pin, which is not High Z at POR.
 ** SMP is not available for the CY8C21434 and CY7C60323: Pin 9 is Vss power.

CY8CPLC20, CY8CLE16P01, CY8C29466 and CY8C27443 PSoC Devices

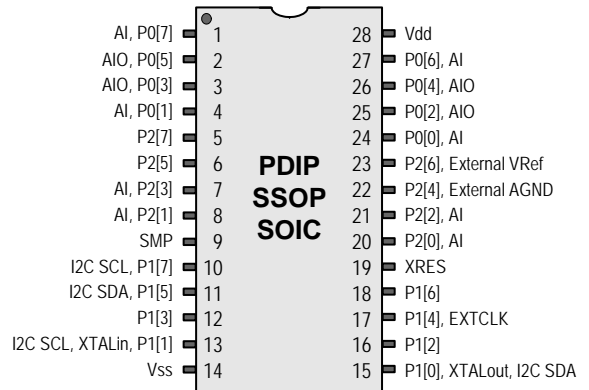

CY8C24423 and CY8C24423A PSoC Devices

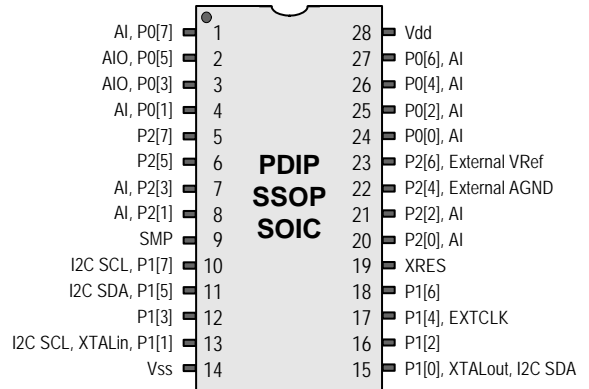

CY8C21534 and CY7C60323 PSoC Devices

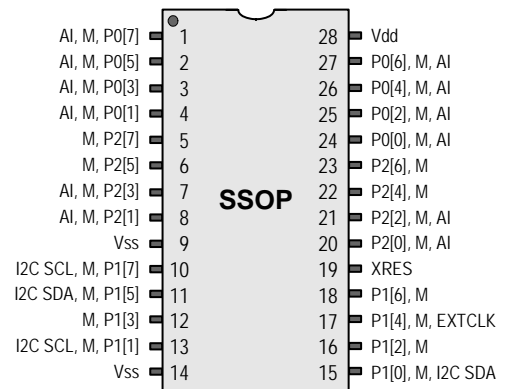
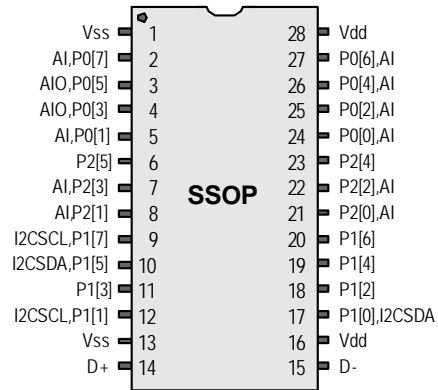

Table 1-6. 28-Pin Part Pinout (SSOP) for the CY7C64215

Pin No.	Type		Name	Description
	Digital	Analog		
1	Power		GND	Ground connection
2	IO	I, M	P0[7]	Analog column mux input, integration input #1
3	IO	IO, M	P0[5]	Analog column mux input and column output, integration input #2.
4	IO	IO, M	P0[3]	Analog column mux input and column output.
5	IO	I, M	P0[1]	Analog column mux input.
6	IO	M	P2[5]	
7	IO	M	P2[3]	Direct switched capacitor block input.
8	IO	M	P2[1]	Direct switched capacitor block input.
9	IO	M	P1[7]	I2C Serial Clock (SCL).
10	IO	M	P1[5]	I2C Serial Data (SDA).
11	IO	M	P1[3]	
12	IO	M	P1[1]	I2C Serial Clock (SCL), ISSP SCLK.
13	Power		GND	Ground connection.
14	USB		D+	
15	USB		D-	
16	Power		Vdd	Supply voltage.
17	IO	M	P1[0]	I2C Serial Clock (SCL), ISSP SDATA.
18	IO	M	P1[2]	
19	IO	M	P1[4]	
20	IO	M	P1[6]	
21	IO	M	P2[0]	Direct switched capacitor block input.
22	IO	M	P2[2]	Direct switched capacitor block input.
23	IO	M	P2[4]	External Analog Ground (AGND) input.
24	IO	M	P0[0]	Analog column mux input.
25	IO	M	P0[2]	Analog column mux input and column output.
26	IO	M	P0[4]	Analog column mux input and column output.
27	IO	M	P0[6]	Analog column mux input.
28	Power		Vdd	Supply voltage.

LEGEND A = Analog, I = Input, O = Output, M = Analog Mux Input.

CY7C64215 PSoC Device



1.1.6 32-Pin Part Pinouts

The 32-pin part table and drawing below is for the CY8C24423, CY8C24423A and CY8C22413 PSoC devices. The CY8C21434 PSoC device has its own 32-pin table and drawing on the next page.

Table 1-7. 32-Pin Part Pinout (QFN**)

Pin No.	Digital	Analog	Name	Description	CY8C24x23	CY8C22x13
1	IO		P2[7]			NC
2	IO		P2[5]			NC
3	IO	I	P2[3]	Direct switched capacitor block input.		NC
4	IO	I	P2[1]	Direct switched capacitor block input.		NC
5	Power		Vss	Ground connection.		
6	Power		SMP			Vss
7	IO		P1[7]	I2C Serial Clock (SCL).		
8	IO		P1[5]	I2C Serial Data (SDA).		
9			NC	No internal connection.		
10	IO		P1[3]			
11	IO		P1[1]*	Crystal (XTALin), I2C Serial Clock (SCL).		
12	Power		Vss	Ground connection.		
13	IO		P1[0]*	Crystal (XTALout), I2C Serial Data (SDA).		
14	IO		P1[2]			
15	IO		P1[4]	Optional External Clock Input (EXTCLK).		
16			NC	No internal connection.		
17	IO		P1[6]			
18	Input		XRES	Active high pin reset with internal pull down.		
19	IO	I	P2[0]	Direct switched capacitor block input.		NC
20	IO	I	P2[2]	Direct switched capacitor block input.		NC
21	IO		P2[4]	External Analog Ground (AGND) input.		NC
22	IO		P2[6]	External Voltage Reference (VRef) input.		NC
23	IO	I	P0[0]	Analog column mux input.		
24	IO	I	P0[2]	Analog column mux input.		
25			NC	No internal connection.		
26	IO	I	P0[4]	Analog column mux input		
27	IO	I	P0[6]	Analog column mux input.		
28	Power		Vdd	Supply voltage.		
29	IO	I	P0[7]	Analog column mux input.		
30	IO	IO	P0[5]	Analog column mux input and column output.		
31	IO	I	P0[3]	Analog column mux input.	AO	
32	IO	I	P0[1]	Analog column mux input.		

LEGEND A = Analog, I = Input, O = Output, NC = No Connection.
 * ISSP pin, which is not High Z at POR.
 ** The QFN package has a center pad that must be connected to ground (Vss).

CY8C24423 and CY8C24423A PSoC Devices

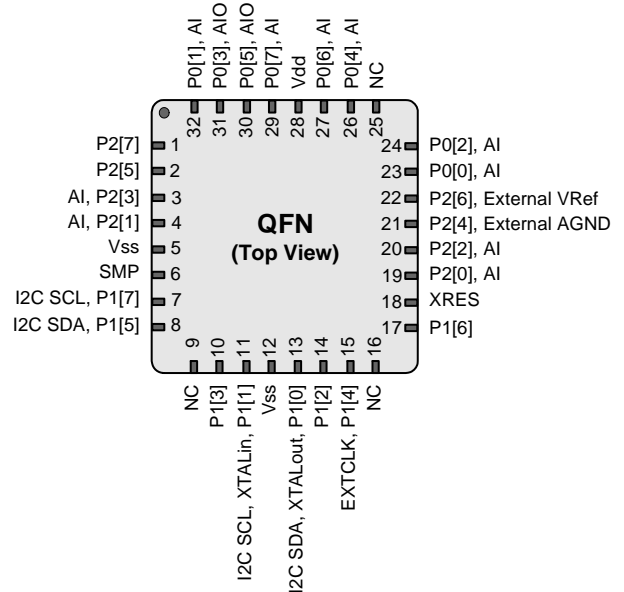

CY8C22213 PSoC Device

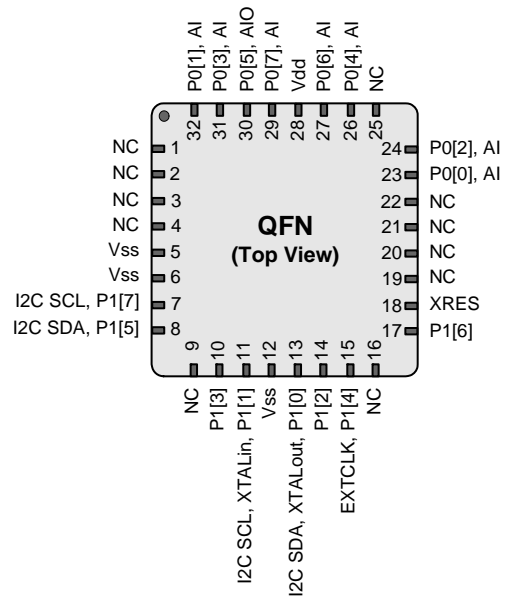
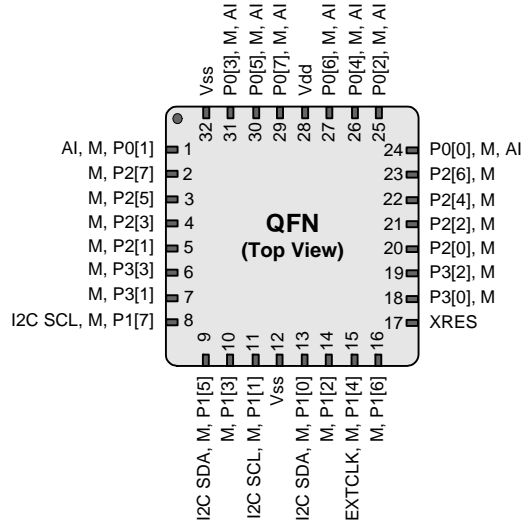

Table 1-8. 32-Pin Part Pinout (QFN**) for the CY8C21x34, CY7C603xx, and CYWUSB6953

Pin No.	Type		Name	Description
	Digital	Analog		
1	IO	I,M	P0[1]	Analog column mux input.
2	IO	M	P2[7]	
3	IO	M	P2[5]	
4	IO	M	P2[3]	
5	IO	M	P2[1]	
6	IO	M	P3[3]	In CY8C21434 part.
6	Power		SMP	Switch Mode Pump (SMP) connection to required external components in CY8C21634 part.
7	IO	M	P3[1]	In CY8C21434 part.
7	Power		Vss	Ground connection in CY8C21634 part.
8	IO	M	P1[7]	I2C Serial Clock (SCL).
9	IO	M	P1[5]	I2C Serial Data (SDA).
10	IO	M	P1[3]	
11	IO	M	P1[1]*	I2C Serial Clock (SCL).
12	Power		Vss	Ground connection.
13	IO	M	P1[0]*	I2C Serial Data (SDA).
14	IO	M	P1[2]	
15	IO	M	P1[4]	Optional External Clock Input (EXTCLK)
16	IO	M	P1[6]	
17	Input		XRES	Active high external reset with internal pull down.
18	IO	M	P3[0]	
19	IO	M	P3[2]	
20	IO	M	P2[0]	
21	IO	M	P2[2]	
22	IO	M	P2[4]	
23	IO	M	P2[6]	
24	IO	I,M	P0[0]	Analog column mux input.
25	IO	I,M	P0[2]	Analog column mux input.
26	IO	I,M	P0[4]	Analog column mux input.
27	IO	I,M	P0[6]	Analog column mux input.
28	Power		Vdd	Supply voltage.
29	IO	I,M	P0[7]	Analog column mux input.
30	IO	I,M	P0[5]	Analog column mux input.
31	IO	I,M	P0[3]	Analog column mux input.
32	Power		Vss	Ground connection.

LEGEND A = Analog, I = Input, and O = Output, M = Analog Mux Input.
 * ISSP pin, which is not High Z at POR.
 ** The QFN package has a center pad that must be connected to ground (Vss).

CY8C21434 and CY7C60323 PSoC Devices



CY8C21634 and CY7C60333 PSoC Devices

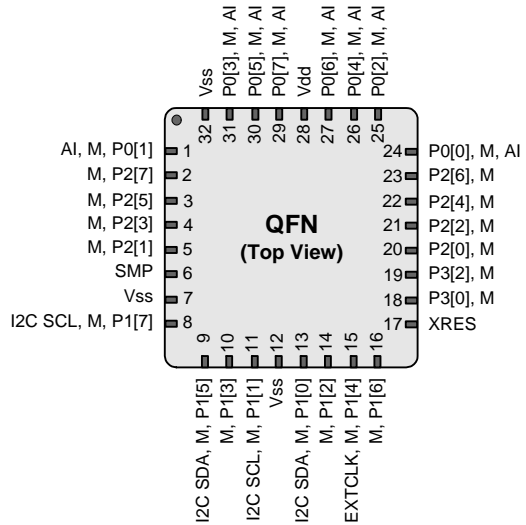

1.1.7 44-Pin Part Pinout

The 44-pin part is for the CY8C29566 and CY8C27543 PSoC devices.

Table 1-9. 44-Pin Part Pinout (TQFP)

Pin No.	Digital	Analog	Name	Description
1	IO		P2[5]	
2	IO	I	P2[3]	Direct switched capacitor block input.
3	IO	I	P2[1]	Direct switched capacitor block input.
4	IO		P4[7]	
5	IO		P4[5]	
6	IO		P4[3]	
7	IO		P4[1]	
8		Power	SMP	Switch Mode Pump (SMP) connection to required external components.
9	IO		P3[7]	
10	IO		P3[5]	
11	IO		P3[3]	
12	IO		P3[1]	
13	IO		P1[7]	I2C Serial Clock (SCL).
14	IO		P1[5]	I2C Serial Data (SDA).
15	IO		P1[3]	
16	IO		P1[1]*	Crystal (XTALin), I2C Serial Clock (SCL).
17		Power	Vss	Ground connection.
18	IO		P1[0]*	Crystal (XTALout), I2C Serial Data (SDA).
19	IO		P1[2]	
20	IO		P1[4]	Optional External Clock Input (EXT-CLK).
21	IO		P1[6]	
22	IO		P3[0]	
23	IO		P3[2]	
24	IO		P3[4]	
25	IO		P3[6]	
26	Input		XRES	Active high pin reset with internal pull down.
27	IO		P4[0]	
28	IO		P4[2]	
29	IO		P4[4]	
30	IO		P4[6]	
31	IO	I	P2[0]	Direct switched capacitor block input.
32	IO	I	P2[2]	Direct switched capacitor block input.
33	IO		P2[4]	External Analog Ground (AGND) input.
34	IO		P2[6]	External Voltage Reference (VRef) input.
35	IO	I	P0[0]	Analog column mux input.
36	IO	IO	P0[2]	Analog column mux input and column output.
37	IO	IO	P0[4]	Analog column mux input and column output
38	IO	I	P0[6]	Analog column mux input.
39		Power	Vdd	Supply voltage.
40	IO	I	P0[7]	Analog column mux input.
41	IO	IO	P0[5]	Analog column mux input and column output.
42	IO	IO	P0[3]	Analog column mux input and column output.
43	IO	I	P0[1]	Analog column mux input.
44	IO		P2[7]	
44	IO		P2[7]	
44	IO		P2[7]	

CY8C29566 and CY8C27543 PSoC Devices

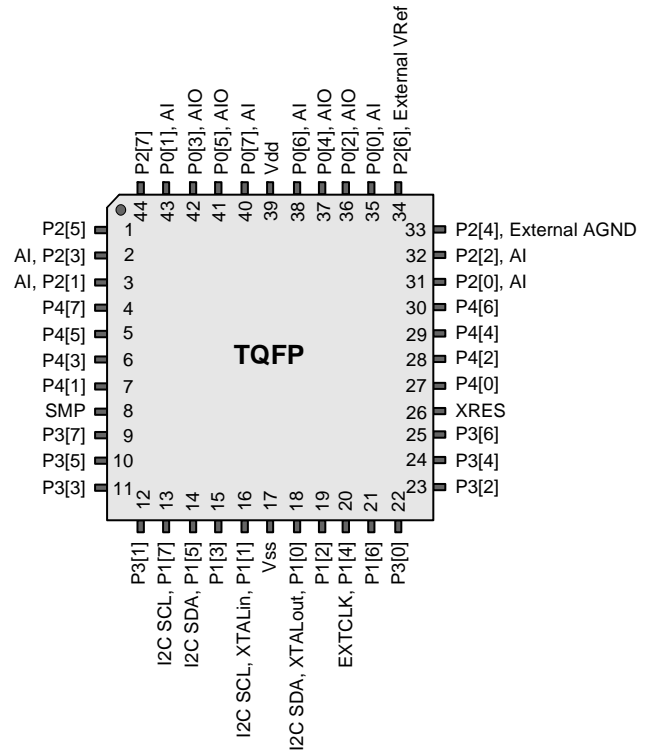

LEGEND A = Analog, I = Input, O = Output.
 * ISSP pin, which is not High Z at POR.

1.1.8 48-Pin Part Pinouts

The 48-pin SSOP part table and drawing below is for the CY8C29666 and CY8C27643 PSoC devices. The 48-pin QFN part for the same PSoC devices have their own table and drawing on the next page. The 48-pin QFN part for the CYWUSB6953 has its own table and drawing on the page after that.

Table 1-10. 48-Pin Part Pinout (SSOP) for the CY8C29666 and CY8C27643

Pin No.	Digital	Analog	Name	Description
1	IO	I	P0[7]	Analog column mux input.
2	IO	IO	P0[5]	Analog column mux input and column output.
3	IO	IO	P0[3]	Analog column mux input and column output.
4	IO	I	P0[1]	Analog column mux input.
5	IO		P2[7]	
6	IO		P2[5]	
7	IO	I	P2[3]	Direct switched capacitor block input.
8	IO	I	P2[1]	Direct switched capacitor block input.
9	IO		P4[7]	
10	IO		P4[5]	
11	IO		P4[3]	
12	IO		P4[1]	
13		Power	SMP	Switch Mode Pump (SMP) connection to required external components.
14	IO		P3[7]	
15	IO		P3[5]	
16	IO		P3[3]	
17	IO		P3[1]	
18	IO		P5[3]	
19	IO		P5[1]	
20	IO		P1[7]	I2C Serial Clock (SCL).
21	IO		P1[5]	I2C Serial Data (SDA).
22	IO		P1[3]	
23	IO		P1[1]*	Crystal (XTALin), I2C Serial Clock (SCL).
24		Power	Vss	Ground connection.
25	IO		P1[0]*	Crystal (XTALout), I2C Serial Data (SDA).
26	IO		P1[2]	
27	IO		P1[4]	Optional External Clock Input (EXT-CLK).
28	IO		P1[6]	
29	IO		P5[0]	
30	IO		P5[2]	
31	IO		P3[0]	
32	IO		P3[2]	
33	IO		P3[4]	
34	IO		P3[6]	
35		Input	XRES	Active high pin reset with internal pull down.
36	IO		P4[0]	

CY8C29666 and CY8C27643 PSoC Devices

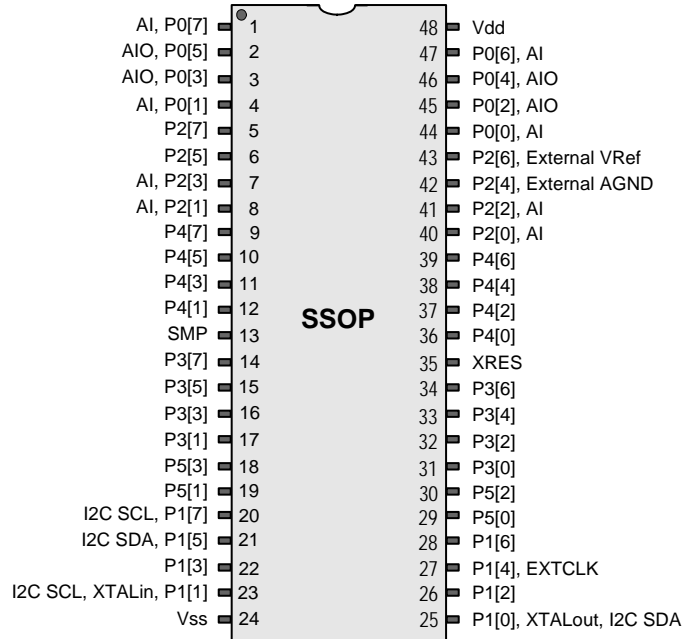

Pin No.	Digital	Analog	Name	Description
37	IO		P4[2]	
38	IO		P4[4]	
39	IO		P4[6]	
40	IO	I	P2[0]	Direct switched capacitor block input.
41	IO	I	P2[2]	Direct switched capacitor block input.
42	IO		P2[4]	External Analog Ground (AGND) input.
43	IO		P2[6]	External Voltage Reference (VRef) input.
44	IO	I	P0[0]	Analog column mux input.
45	IO	IO	P0[2]	Analog column mux input and column output.
46	IO	IO	P0[4]	Analog column mux input and column output.
47	IO	I	P0[6]	Analog column mux input.
48		Power	Vdd	Supply voltage.

LEGEND A = Analog, I = Input, O = Output.
* ISSP pin, which is not High Z at POR.

Table 1-11. 48-Pin Part Pinout (QFN**) for the CY8CPLC20, CY8CLED16P01, CY8C29666, and CY8C27643

Pin No.	Digital	Analog	Name	Description
1	IO	I	P2[3]	Direct switched capacitor block input.
2	IO	I	P2[1]	Direct switched capacitor block input.
3	IO		P4[7]	
4	IO		P4[5]	
5	IO		P4[3]	
6	IO		P4[1]	
7		Power	SMP	Switch Mode Pump (SMP) connection to required external components.
8	IO		P3[7]	
9	IO		P3[5]	
10	IO		P3[3]	
11	IO		P3[1]	
12	IO		P5[3]	
13	IO		P5[1]	
14	IO		P1[7]	I2C Serial Clock (SCL).
15	IO		P1[5]	I2C Serial Data (SDA).
16	IO		P1[3]	
17	IO		P1[1]*	Crystal (XTALin), I2C Serial Clock (SCL).
18		Power	Vss	Ground connection.
19	IO		P1[0]*	Crystal (XTALout), I2C Serial Data (SDA).
20	IO		P1[2]	
21	IO		P1[4]	Optional External Clock Input (EXT-CLK).
22	IO		P1[6]	
23	IO		P5[0]	
24	IO		P5[2]	
25	IO		P3[0]	
26	IO		P3[2]	
27	IO		P3[4]	
28	IO		P3[6]	
29	Input		XRES	Active high pin reset with internal pull down.
30	IO		P4[0]	
31	IO		P4[2]	
32	IO		P4[4]	
33	IO		P4[6]	
34	IO	I	P2[0]	Direct switched capacitor block input.
35	IO	I	P2[2]	Direct switched capacitor block input.
36	IO		P2[4]	External Analog Ground (AGND) input.

**CY8CPLC20, CY8CLED16P01, CY8C29666. and CY8C27643
PSoC Devices**

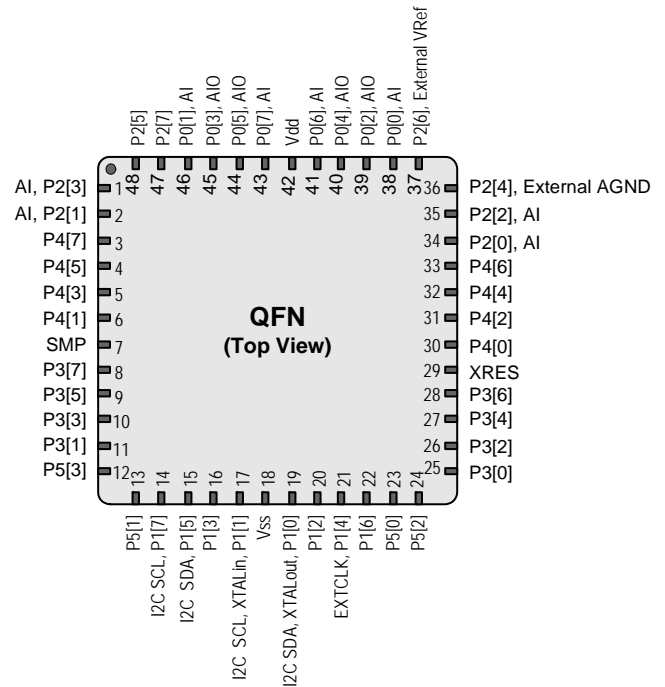

Pin No.	Digital	Analog	Name	Description
37	IO		P2[6]	External Voltage Reference (VRef) input.
38	IO	I	P0[0]	Analog column mux input.
39	IO	IO	P0[2]	Analog column mux input and column output.
40	IO	IO	P0[4]	Analog column mux input and column output.
41	IO	I	P0[6]	Analog column mux input.
42		Power	Vdd	Supply voltage.
43	IO	I	P0[7]	Analog column mux input.
44	IO	IO	P0[5]	Analog column mux input and column output.
45	IO	IO	P0[3]	Analog column mux input and column output.
46	IO	I	P0[1]	Analog column mux input.
47	IO		P2[7]	
48	IO		P2[5]	

LEGEND A = Analog, I = Input, O = Output.
 * ISSP pin, which is not High Z at POR.
 ** The QFN package has a center pad that must be connected to ground (Vss).

Table 1-12. 48-Pin Part Pinout (QFN*) for the CYWUSB6953

Pin No.	Name	Type	Die	Description
1	GND			Ground Connection.
2	RFOUT		Radio	Modulated RF signal to be transmitted.
3	GND			Ground Connection.
4	V _{CC}			Supply Voltage.
5	GND			Ground Connection.
6	P1[6]	IO/M	MCU	
7	XRES	I	MCU	Active HIGH external reset with internal pull down.
8	P2[0]	IO/M	MCU	Direct switched capacitor block input.
9	P2[2]	IO/M	MCU	Direct switched capacitor block input.
10	P2[4]	IO/M	MCU	
11	V _{CC}			Supply Voltage.
12	P2[6]	IO/M	MCU	
13	P0[0]	IO/M	MCU	Analog Column Mux Input.
14	P0[2]	IO/M	MCU	Analog Column Mux Input.
15	V _{CC}			Supply Voltage.
16	NC			No Connection.
17	IRQ	IO	Radio, MCU	Radio Interrupt. Connect pins 17 and 21 on the application board.
18	V _{CC}			Supply Voltage.
19	RSVD			Connect to Ground.
20	RSVD			Connect to Ground.
21	IRQ	IO	Radio, MCU	Radio Interrupt. Connect pins 17 and 21 on the application board.
22	NC			No Connection.
23	MISO	IO	Radio, MCU	Radio SPI Master In, Slave Out. Connect pins 23 and 25 on the application board.
24	X13OUT	O	Radio	Reference Clock Output.
25	MISO	IO	Radio, MCU	Radio SPI Master In, Slave Out. Connect pins 23 and 25 on the application board.
26	V _{CC}			Supply Voltage.
27	V _{CC}			Supply Voltage.
28	P2[7]	IO/M	MCU	
29	P2[5]	IO/M	MCU	Direct switched capacitor block input.
30	P2[3]	IO/M	MCU	Direct switched capacitor block input.
31	P2[1]	IO/M	MCU	Direct switched capacitor block input.
32	V _{CC}			Supply Voltage.
33	P1[7]	IO/M	MCU	I2C Serial Clock (SCL).
34	P1[5]	IO/M	MCU	I2C Serial Data (SDA).
35	PACTL	IO	Radio	External Power Amplifier control. Pull down or make output.
36	P1[1]	IO/M	MCU	I2C Serial Clock (SCL).

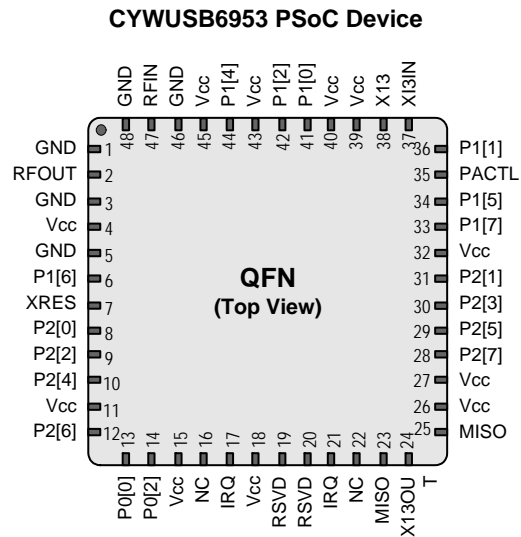

Pin No.	Name	Type	Die	Description
37	X13IN	I	Radio	Crystal Input.
38	X13	I	Radio	Crystal Input.
39	V _{CC}			Supply Voltage.
40	V _{CC}			Supply Voltage.
41	P1[0]	IO/M	MCU	I2C Serial Data (SDA).
42	P1[2]	IO/M	MCU	
43	V _{CC}			Supply Voltage.
44	P1[4]	IO/M	MCU	Optional External Clock Input (EXT-CLK).
45	V _{CC}			Supply Voltage.
46	GND			Ground Connection.
47	RFIN		Radio	Modulated RF signal received.
48	GND			Ground Connection.

LEGEND A = Analog, I = Input, O = Output.
 * The QFN package has a center pad that must be connected to ground (V_{SS}).

1.1.9 56-Pin Part Pinouts

The 56-pin QFN part table and drawing below is for the CY8C24794 PSoC device. The CY8C24894 PSoC device has its own 56-pin QFN table and drawing on the next page, along with an XRES pin. 56-pin OCD parts are presented at the end of this section.

Table 1-13. 56-Pin Part Pinout (QFN **)

Pin No.	Type		Name	Description	
	Digital	Analog			
1	IO	I,M	P2[3]	Direct switched capacitor block input.	
2	IO	I,M	P2[1]	Direct switched capacitor block input.	
3	IO	M	P4[7]		
4	IO	M	P4[5]		
5	IO	M	P4[3]		
6	IO	M	P4[1]		
7	IO	M	P3[7]		
8	IO	M	P3[5]		
9	IO	M	P3[3]		
10	IO	M	P3[1]		
11	IO	M	P5[7]		
12	IO	M	P5[5]		
13	IO	M	P5[3]		
14	IO	M	P5[1]		
15	IO	M	P1[7]	I2C Serial Clock (SCL).	
16	IO	M	P1[5]	I2C Serial Data (SDA).	
17	IO	M	P1[3]		
18	IO	M	P1[1]*	I2C Serial Clock (SCL).	
19	Power		Vss	Ground connection.	
20	USB		D+		
21	USB		D-		
22	Power		Vdd	Supply voltage.	
23	IO		P7[7]		
24	IO		P7[0]		
25	IO	M	P1[0]*	I2C Serial Data (SDA).	
26	IO	M	P1[2]		
27	IO	M	P1[4]	Optional External Clock Input (EXT-CLK).	
28	IO	M	P1[6]		
29	IO	M	P5[0]		
30	IO	M	P5[2]		
31	IO	M	P5[4]		
32	IO	M	P5[6]		
33	IO	M	P3[0]		
34	IO	M	P3[2]		
35	IO	M	P3[4]		
36	IO	M	P3[6]		
37	IO	M	P4[0]		
38	IO	M	P4[2]		
39	IO	M	P4[4]		
40	IO	M	P4[6]		
41	IO	I,M	P2[0]	Direct switched capacitor block input.	
42	IO	I,M	P2[2]	Direct switched capacitor block input.	
43	IO	M	P2[4]	External Analog Ground (AGND) input.	
	Pin No.	Type	Name	Description	
	44	IO	M	P2[6]	External Voltage Reference (VREF) input.
	45	IO	I,M	P0[0]	Analog column mux input.
	46	IO	I,M	P0[2]	Analog column mux input.
	47	IO	I,M	P0[4]	Analog column mux input.
	48	IO	I,M	P0[6]	Analog column mux input.
	49	Power	Vdd	Supply voltage.	
	50	Power	Vss	Ground connection.	
	51	IO	I,M	P0[7]	Analog column mux input.
	52	IO	I,M	P0[5]	Analog column mux input and column output.
	53	IO	I,M	P0[3]	Analog column mux input and column output.
	54	IO	I,M	P0[1]	Analog column mux input.
	55	IO	M	P2[7]	
	56	IO	M	P2[5]	

CY8C24794 and CY7C64215 PSoC Devices

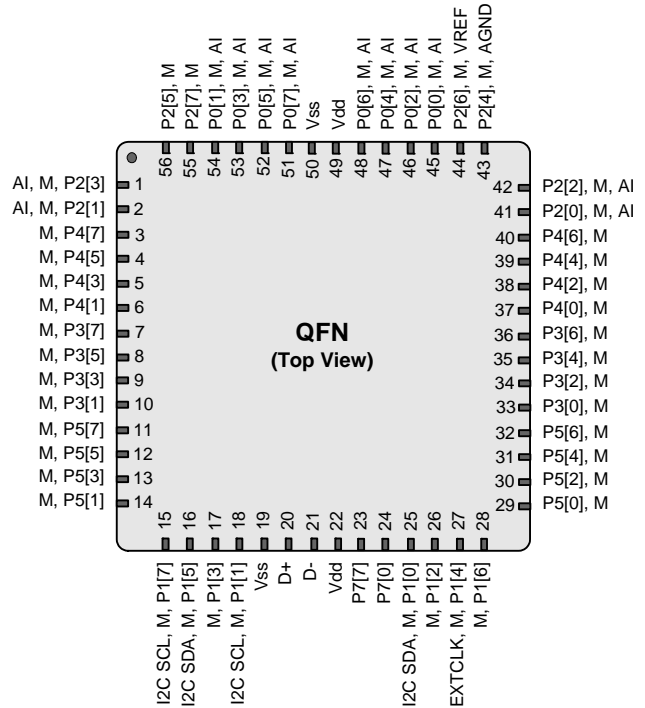

LEGEND A = Analog, I = Input, O = Output, and M = Analog Mux Input.
 * ISSP pin, which is not High Z at POR.
 ** The QFN package has a center pad that must be connected to ground (Vss).

Table 1-14. 56-Pin Part Pinout (QFN**) for the CY8C24x94

Pin No.	Type		Name	Description
	Digital	Analog		
1	IO		P2[3]	Direct switched capacitor block input.
2	IO		P2[1]	Direct switched capacitor block input.
3	IO		P4[7]	
4	IO		P4[5]	
5	IO		P4[3]	
6	IO		P4[1]	
7	IO		P3[7]	
8	IO		P3[5]	
9	IO		P3[3]	
10	IO		P3[1]	
11	IO		P5[7]	
12	IO		P5[5]	
13	IO		P5[3]	
14	IO		P5[1]	
15	IO		P1[7]	I2C Serial Clock (SCL).
16	IO		P1[5]	I2C Serial Data (SDA).
17	IO		P1[3]	
18	IO		P1[1]*	I2C Serial Clock (SCL).
19	Power		Vss	Ground connection.
20	USB		D+	
21	USB		D-	
22	Power		Vdd	Supply voltage.
23	IO		P7[7]	
24	IO		P7[0]	
25	IO		P1[0]*	I2C Serial Data (SDA).
26	IO		P1[2]	
27	IO		P1[4]	Optional External Clock Input (EXT-CLK).
28	IO		P1[6]	
29	IO		P5[0]	
30	IO		P5[2]	
31	IO		P5[4]	
32	IO		P5[6]	
33	IO		P3[0]	
34	IO		P3[2]	
35	IO		P3[4]	
36	Input		XRES	Active high pin reset with internal pull down.
37	IO		P4[0]	
38	IO		P4[2]	
39	IO		P4[4]	
40	IO		P4[6]	
41	IO		P2[0]	Direct switched capacitor block input.
42	IO		P2[2]	Direct switched capacitor block input.
43	IO		P2[4]	External Analog Ground (AGND) input.
44	IO		P2[6]	External Voltage Reference (VREF) input.
45	IO		P0[0]	Analog column mux input.
46	IO		P0[2]	Analog column mux input.
47	IO		P0[4]	Analog column mux input.
48	IO		P0[6]	Analog column mux input.
49	Power		Vdd	Supply voltage.
50	Power		Vss	Ground connection.
51	IO		P0[7]	Analog column mux input.
52	IO		P0[5]	Analog column mux input and column output.
53	IO		P0[3]	Analog column mux input and column output.
54	IO		P0[1]	Analog column mux input.
55	IO		P2[7]	
56	IO		P2[5]	

CY8C24894 PSoC Device

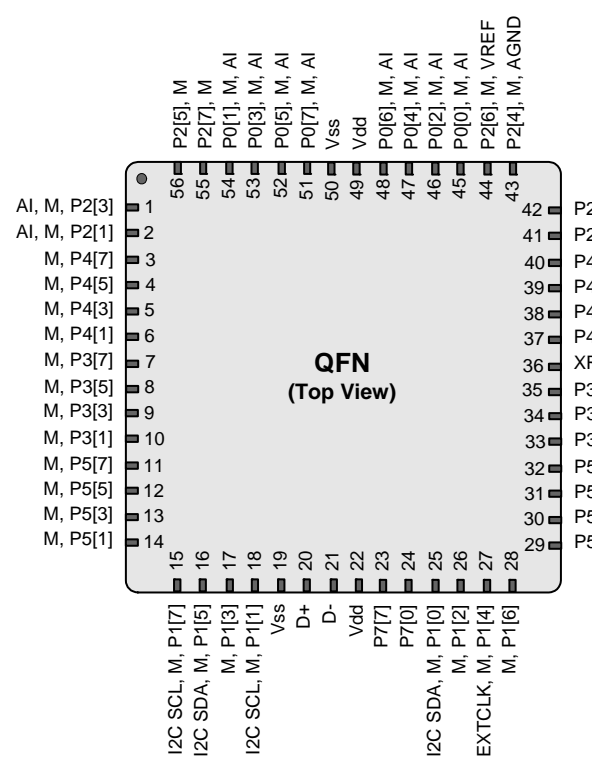

QFN (Top View)

LEGEND A = Analog, I = Input, O = Output, and M = Analog Mux Input.
* ISSP pin, which is not High Z at POR.
** The QFN package has a center pad that must be connected to ground (Vss).

The 56-pin OCD (On-Chip Debug) part is for the CY8C27x43 (CY8C27002) and CY8C24x23A (CY8C24000A) PSoC devices. The CY8C21x34 and CY8C21x23 PSoC device pinouts are shown on the next page.

Note OCD parts are only used for in-circuit debugging. OCD parts are NOT available for production.

Table 1-15. 56-Pin OCD Part Pinout (SSOP)

Pin No.	Name	Description
1	NC	No internal connection.
2	P0[7]	Analog column mux input: AI.
3	P0[5]	Analog column mux input and column output: AIO.
4	P0[3]	Analog column mux input and column output: AIO.
5	P0[1]	Analog column mux input: AI.
6	P2[7]	
7	P2[5]	
8	P2[3]	Direct switched capacitor block input: AI.
9	P2[1]	Direct switched capacitor block input: AI.
10	P4[7]	
11	P4[5]	
12	P4[3]	
13	P4[1]	
14	OCDE	OCD even data IO.
15	OCDO	OCD odd data output.
16	SMP	Switch Mode Pump (SMP) connection to required external components.
17	P3[7]	
18	P3[5]	
19	P3[3]	
20	P3[1]	
21	P5[3]	
22	P5[1]	
23	P1[7]	I2C Serial Clock (SCL).
24	P1[5]	I2C Serial Data (SDA).
25	NC	No internal connection.
26	P1[3]	
27	P1[1]*	Crystal (XTALin), I2C Serial Clock (SCL).
28	Vss	Ground connection.
29	NC	No internal connection.
30	NC	No internal connection.
31	P1[0]*	Crystal (XTALout), I2C Serial Data (SDA).
32	P1[2]	
33	P1[4]	Optional External Clock Input (EXTCLK).
34	P1[6]	
35	P5[0]	
36	P5[2]	
37	P3[0]	
38	P3[2]	
39	P3[4]	
40	P3[6]	
41	XRES	Active high pin reset with internal pull down.
42	HCLK	OCD high speed clock output.
43	CCLK	OCD CPU clock output.

CY8C27002 and CY8C24000A OCD PSoC Devices

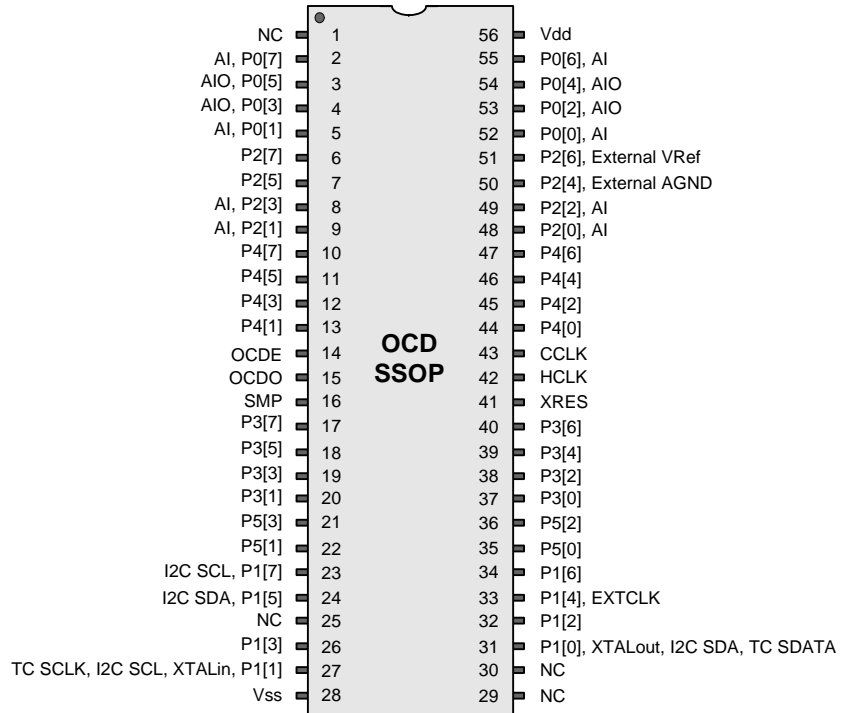

NOT FOR PRODUCTION

Pin No.	Name	Description
44	P4[0]	
45	P4[2]	
46	P4[4]	
47	P4[6]	
48	P2[0]	Direct switched capacitor block input: AI.
49	P2[2]	Direct switched capacitor block input: AI.
50	P2[4]	External Analog Ground (AGND).
51	P2[6]	External Voltage Reference (VRef).
52	P0[0]	Analog column mux input: AI.
53	P0[2]	Analog column mux input and column output: AIO.
54	P0[4]	Analog column mux input and column output: AIO.
55	P0[6]	Analog column mux input: AI.
56	Vdd	Supply voltage.

LEGEND A = Analog, I = Input, O = Output.
 * ISSP pin, which is not High Z at POR.

Pin Information

The 56-pin OCD part for the CY8C21x34 (CY8C21001) and CY8C21x23 (CY8C21002) PSoC devices is shown below. Note that the CY8C21x23 uses the CY8C21x34 device for OCD.

Note OCD parts are only used for in-circuit debugging. OCD parts are NOT available for production.

Table 1-16. 56-Pin OCD Part Pinout (SSOP)

Pin No.	Name	Description
1	Vss	Ground connection.
2	P0[7]	Analog column mux input: AI.
3	P0[5]	Analog column mux input: AI.
4	P0[3]	Analog column mux input: AI.
5	P0[1]	Analog column mux input: AI.
6	P2[7]	
7	P2[5]	
8	P2[3]	
9	P2[1]	
10	NC	No internal connection.
11	NC	No internal connection.
12	NC	No internal connection.
13	NC	No internal connection.
14	OCDE	OCD even data IO.
15	OCDO	OCD odd data output.
16	SMP	Switch Mode Pump (SMP) connection to required external components.
17	Vss	Ground connection.
18	Vss	Ground connection.
19	P3[3]	
20	P3[1]	
21	NC	No internal connection.
22	NC	No internal connection.
23	P1[7]	I2C Serial Clock (SCL).
24	P1[5]	I2C Serial Data (SDA).
25	NC	No internal connection.
26	P1[3]	
27	P1[1]*	I2C Serial Clock (SCL).
28	Vss	Ground connection.
29	NC	No internal connection.
30	NC	No internal connection.
31	P1[0]*	I2C Serial Data (SDA).
32	P1[2]	
33	P1[4]	Optional External Clock Input (EXTCLK).
34	P1[6]	
35	NC	No internal connection.
36	NC	No internal connection.
37	NC	No internal connection.
38	NC	No internal connection.
39	NC	No internal connection.
40	NC	No internal connection.
41	XRES	Active high pin reset with internal pull down.
42	HCLK	OCD high speed clock output.
43	CCLK	OCD CPU clock output.

CY8C21001 and CY8C21002 OCD PSoC Devices

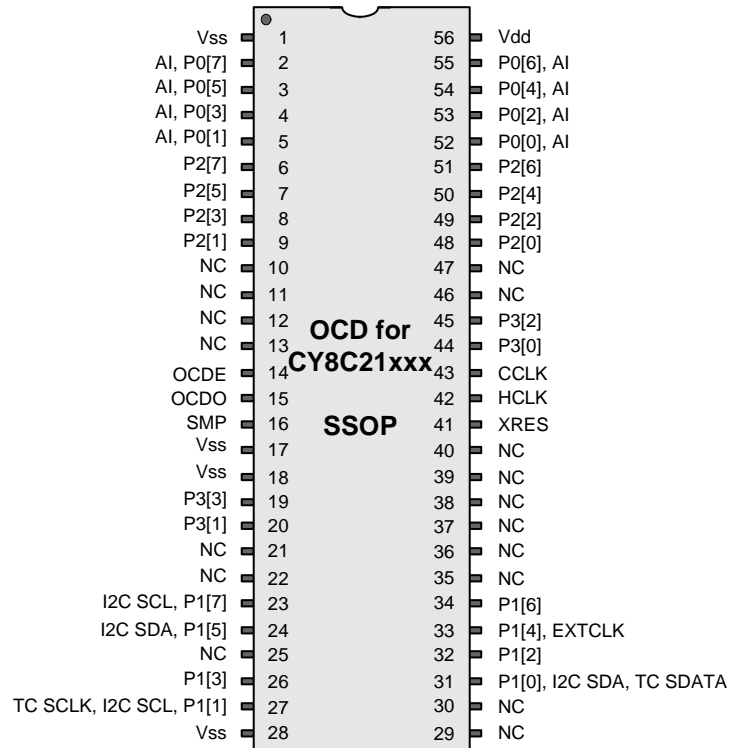

NOT FOR PRODUCTION

Pin No.	Name	Description
44	P3[0]	
45	P3[2]	
46	NC	No internal connection.
47	NC	No internal connection.
48	P2[0]	
49	P2[2]	
50	P2[4]	
51	P2[6]	
52	P0[0]	Analog column mux input: AI.
53	P0[2]	Analog column mux input: AI.
54	P0[4]	Analog column mux input: AI.
55	P0[6]	Analog column mux input: AI.
56	Vdd	Supply voltage.

LEGEND A: Analog, I: Input, O: Output.

* ISSP pin, which is not High Z at POR.

1.1.10 68-Pin Part Pinouts

The 68-pin QFN part table and drawing below is for the CY8C24994 PSoC device.

Table 1-17. 68-Pin Part Pinout (QFN **)

Pin No.	Type		Name	Description
	Digital	Analog		
1	IO	M	P4[7]	
2	IO	M	P4[5]	
3	IO	M	P4[3]	
4	IO	M	P4[1]	
5			NC	No internal connection.
6			NC	No internal connection.
7	Power		Vss	Ground connection.
8	IO	M	P3[7]	
9	IO	M	P3[5]	
10	IO	M	P3[3]	
11	IO	M	P3[1]	
12	IO	M	P5[7]	
13	IO	M	P5[5]	
14	IO	M	P5[3]	
15	IO	M	P5[1]	
16	IO	M	P1[7]	I2C Serial Clock (SCL).
17	IO	M	P1[5]	I2C Serial Data (SDA).
18	IO	M	P1[3]	
19	IO	M	P1[1]*	I2C Serial Clock (SCL).
20	Power		Vss	Ground connection.
21	USB		D+	
22	USB		D-	
23	Power		Vdd	Supply voltage.
24	IO		P7[7]	
25	IO		P7[6]	
26	IO		P7[5]	
27	IO		P7[4]	
28	IO		P7[3]	
29	IO		P7[2]	
30	IO		P7[1]	
31	IO		P7[0]	
32	IO	M	P1[0]*	I2C Serial Data (SDA).
33	IO	M	P1[2]	
34	IO	M	P1[4]	Optional External Clock Input (EXT-CLK).
35	IO	M	P1[6]	
36	IO	M	P5[0]	
37	IO	M	P5[2]	
38	IO	M	P5[4]	
39	IO	M	P5[6]	
40	IO	M	P3[0]	
41	IO	M	P3[2]	
42	IO	M	P3[4]	
43	IO	M	P3[6]	
44			NC	No internal connection.
45			NC	No internal connection.
46	Input		XRES	Active high pin reset with internal pull down.
47	IO	M	P4[0]	
48	IO	M	P4[2]	
49	IO	M	P4[4]	

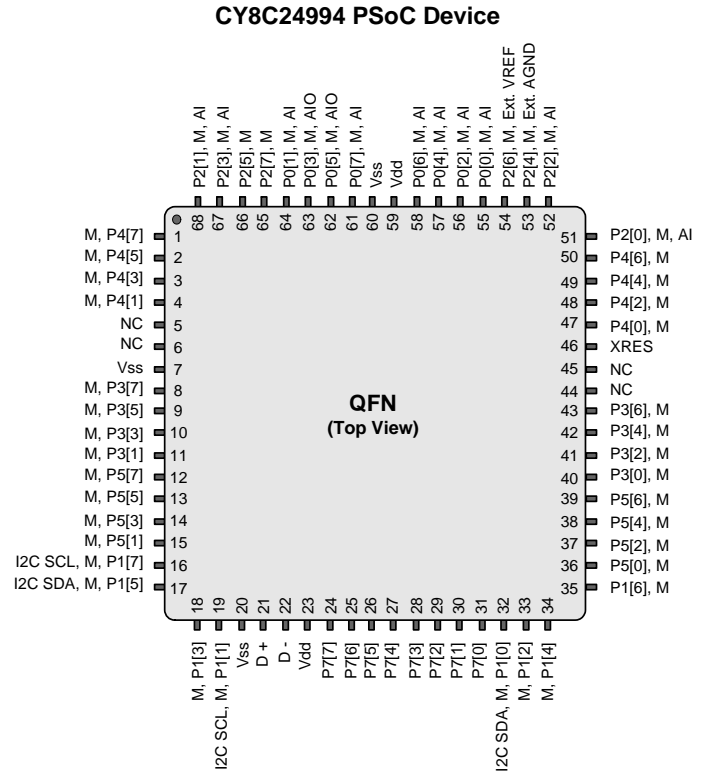

Pin No.	Type		Name	Description
	Digital	Analog		
50	IO	M	P4[6]	
51	IO	I,M	P2[0]	Direct switched capacitor block input.
52	IO	I,M	P2[2]	Direct switched capacitor block input.
53	IO	M	P2[4]	External Analog Ground (AGND) input.
54	IO	M	P2[6]	External Voltage Reference (VREF) input.
55	IO	I,M	P0[0]	Analog column mux input.
56	IO	I,M	P0[2]	Analog column mux input and column output.
57	IO	I,M	P0[4]	Analog column mux input and column output.
58	IO	I,M	P0[6]	Analog column mux input.
59	Power		Vdd	Supply voltage.
60	Power		Vss	Ground connection.
61	IO	I,M	P0[7]	Analog column mux input, integration input #1.
62	IO	IO,M	P0[5]	Analog column mux input and column output, integration input #2.
63	IO	IO,M	P0[3]	Analog column mux input and column output.
64	IO	I,M	P0[1]	Analog column mux input.
65	IO	M	P2[7]	
66	IO	M	P2[5]	
67	IO	I,M	P2[3]	Direct switched capacitor block input.
68	IO	I,M	P2[1]	Direct switched capacitor block input.

LEGEND A = Analog, I = Input, O = Output, and M = Analog Mux Input.
 * ISSP pin, which is not High Z at POR.
 ** The QFN package has a center pad that must be connected to ground (Vss).

Pin Information

The 68-pin QFN part table and drawing below is for the CY8C24094 OCD PSoC device.

Note OCD parts are only used for in-circuit debugging. OCD parts are NOT available for production.

Table 1-18. 68-Pin OCD Part Pinout (QFN)**

Pin No.	Type		Name	Description
	Digital	Analog		
1	IO	M	P4[7]	
2	IO	M	P4[5]	
3	IO	M	P4[3]	
4	IO	M	P4[1]	
5			OCDE	OCD even data IO.
6			OCDO	OCD odd data output.
7	Power		Vss	Ground connection.
8	IO	M	P3[7]	
9	IO	M	P3[5]	
10	IO	M	P3[3]	
11	IO	M	P3[1]	
12	IO	M	P5[7]	
13	IO	M	P5[5]	
14	IO	M	P5[3]	
15	IO	M	P5[1]	
16	IO	M	P1[7]	I2C Serial Clock (SCL).
17	IO	M	P1[5]	I2C Serial Data (SDA).
18	IO	M	P1[3]	
19	IO	M	P1[1]*	I2C Serial Clock (SCL).
20	Power		Vss	Ground connection.
21	USB		D+	
22	USB		D-	
23	Power		Vdd	Supply voltage.
24	IO		P7[7]	
25	IO		P7[6]	
26	IO		P7[5]	
27	IO		P7[4]	
28	IO		P7[3]	
29	IO		P7[2]	
30	IO		P7[1]	
31	IO		P7[0]	
32	IO	M	P1[0]*	I2C Serial Data (SDA).
33	IO	M	P1[2]	
34	IO	M	P1[4]	Optional External Clock Input (EXT-CLK).
35	IO	M	P1[6]	
36	IO	M	P5[0]	
37	IO	M	P5[2]	
38	IO	M	P5[4]	
39	IO	M	P5[6]	
40	IO	M	P3[0]	
41	IO	M	P3[2]	
42	IO	M	P3[4]	
43	IO	M	P3[6]	
44			HCLK	OCD high speed clock output.
45			CCLK	OCD CPU clock output.
46	Input		XRES	Active high pin reset with internal pull down.
47	IO	M	P4[0]	
48	IO	M	P4[2]	
49	IO	M	P4[4]	

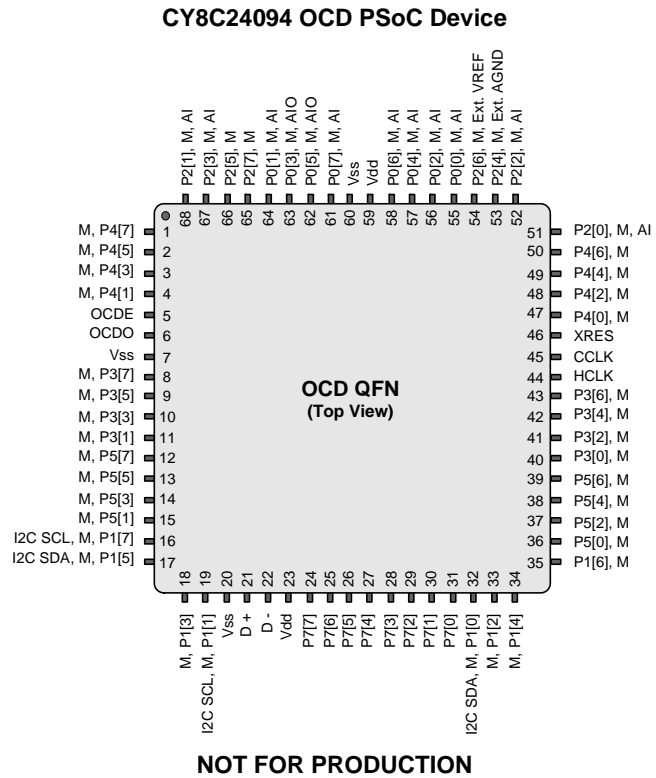

Pin No.	Type		Name	Description
	Digital	Analog		
50	IO	M	P4[6]	
51	IO	I,M	P2[0]	Direct switched capacitor block input.
52	IO	I,M	P2[2]	Direct switched capacitor block input.
53	IO	M	P2[4]	External Analog Ground (AGND) input.
54	IO	M	P2[6]	External Voltage Reference (VREF) input.
55	IO	I,M	P0[0]	Analog column mux input.
56	IO	I,M	P0[2]	Analog column mux input and column output.
57	IO	I,M	P0[4]	Analog column mux input and column output.
58	IO	I,M	P0[6]	Analog column mux input.
59	Power		Vdd	Supply voltage.
60	Power		Vss	Ground connection.
61	IO	I,M	P0[7]	Analog column mux input, integration input #1.
62	IO	IO,M	P0[5]	Analog column mux input and column output, integration input #2.
63	IO	IO,M	P0[3]	Analog column mux input and column output.
64	IO	I,M	P0[1]	Analog column mux input.
65	IO	M	P2[7]	
66	IO	M	P2[5]	
67	IO	I,M	P2[3]	Direct switched capacitor block input.
68	IO	I,M	P2[1]	Direct switched capacitor block input.

LEGEND A = Analog, I = Input, O = Output, and M = Analog Mux Input.
 * ISSP pin, which is not High Z at POR.
 ** The QFN package has a center pad that must be connected to ground (Vss).

1.1.11 100-Pin Part Pinouts

The 100-pin part is for the CY8C29866 PSoC device. The 100-pin OCD parts for the CY8CPLC20, CYLED16P01, CY8C29x66, and CY8C24x94 follow.

Table 1-19. 100-Pin Part Pinout (TQFP)

Pin No.	Digital	Analog	Name	Description	Pin No.	Digital	Analog	Name	Description
1			NC	No internal connection.	51			NC	No internal connection.
2			NC	No internal connection.	52	IO		P5[0]	
3	IO	I	P0[1]	Analog column mux input.	53	IO		P5[2]	
4	IO		P2[7]		54	IO		P5[4]	
5	IO		P2[5]		55	IO		P5[6]	
6	IO	I	P2[3]	Direct switched capacitor block input.	56	IO		P3[0]	
7	IO	I	P2[1]	Direct switched capacitor block input.	57	IO		P3[2]	
8	IO		P4[7]		58	IO		P3[4]	
9	IO		P4[5]		59	IO		P3[6]	
10	IO		P4[3]		60			NC	No internal connection.
11	IO		P4[1]		61			NC	No internal connection.
12			NC	No internal connection.	62		Input	XRES	Active high pin reset with internal pull down.
13			NC	No internal connection.	63	IO		P4[0]	
14	Power		SMP	Switch Mode Pump (SMP) connection to required external components.	64	IO		P4[2]	
15	Power		Vss	Ground connection.	65	Power		Vss	Ground connection.
16	IO		P3[7]		66	IO		P4[4]	
17	IO		P3[5]		67	IO		P4[6]	
18	IO		P3[3]		68	IO	I	P2[0]	Direct switched capacitor block input.
19	IO		P3[1]		69	IO	I	P2[2]	Direct switched capacitor block input.
20	IO		P5[7]		70	IO		P2[4]	External Analog Ground (AGND) input.
21	IO		P5[5]		71			NC	No internal connection.
22	IO		P5[3]		72	IO		P2[6]	External Voltage Reference (VREF) input.
23	IO		P5[1]		73			NC	No internal connection.
24	IO		P1[7]	I2C Serial Clock (SCL).	74	IO	I	P0[0]	Analog column mux input.
25			NC	No internal connection.	75			NC	No internal connection.
26			NC	No internal connection.	76			NC	No internal connection.
27			NC	No internal connection.	77	IO	IO	P0[2]	Analog column mux input and column output.
28	IO		P1[5]	I2C Serial Data (SDA).	78			NC	No internal connection.
29	IO		P1[3]		79	IO	IO	P0[4]	Analog column mux input and column output.
30	IO		P1[1]*	Crystal (XTALin), I2C Serial Clock (SCL).	80			NC	No internal connection.
31			NC	No internal connection.	81	IO	I	P0[6]	Analog column mux input.
32	Power		Vdd	Supply voltage.	82	Power		Vdd	Supply voltage.
33			NC	No internal connection.	83	Power		Vdd	Supply voltage.
34	Power		Vss	Ground connection.	84	Power		Vss	Ground connection.
35			NC	No internal connection.	85	Power		Vss	Ground connection.
36	IO		P7[7]		86	IO		P6[0]	
37	IO		P7[6]		87	IO		P6[1]	
38	IO		P7[5]		88	IO		P6[2]	
39	IO		P7[4]		89	IO		P6[3]	
40	IO		P7[3]		90	IO		P6[4]	
41	IO		P7[2]		91	IO		P6[5]	
42	IO		P7[1]		92	IO		P6[6]	
43	IO		P7[0]		93	IO		P6[7]	
44	IO		P1[0]*	Crystal (XTALout), I2C Serial Data (SDA).	94			NC	No internal connection.
45	IO		P1[2]		95	IO	I	P0[7]	Analog column mux input.
46	IO		P1[4]	Optional External Clock Input (EXTCLK).	96			NC	No internal connection.
47	IO		P1[6]		97	IO	IO	P0[5]	Analog column mux input and column output.
48			NC	No internal connection.	98			NC	No internal connection.
49			NC	No internal connection.	99	IO	IO	P0[3]	Analog column mux input and column output.
50			NC	No internal connection.	100			NC	No internal connection.

LEGEND A = Analog, I = Input, O = Output, NC = No Connection.
 * ISSP pin, which is not High Z at POR.

CY8C29866 PSoC Device

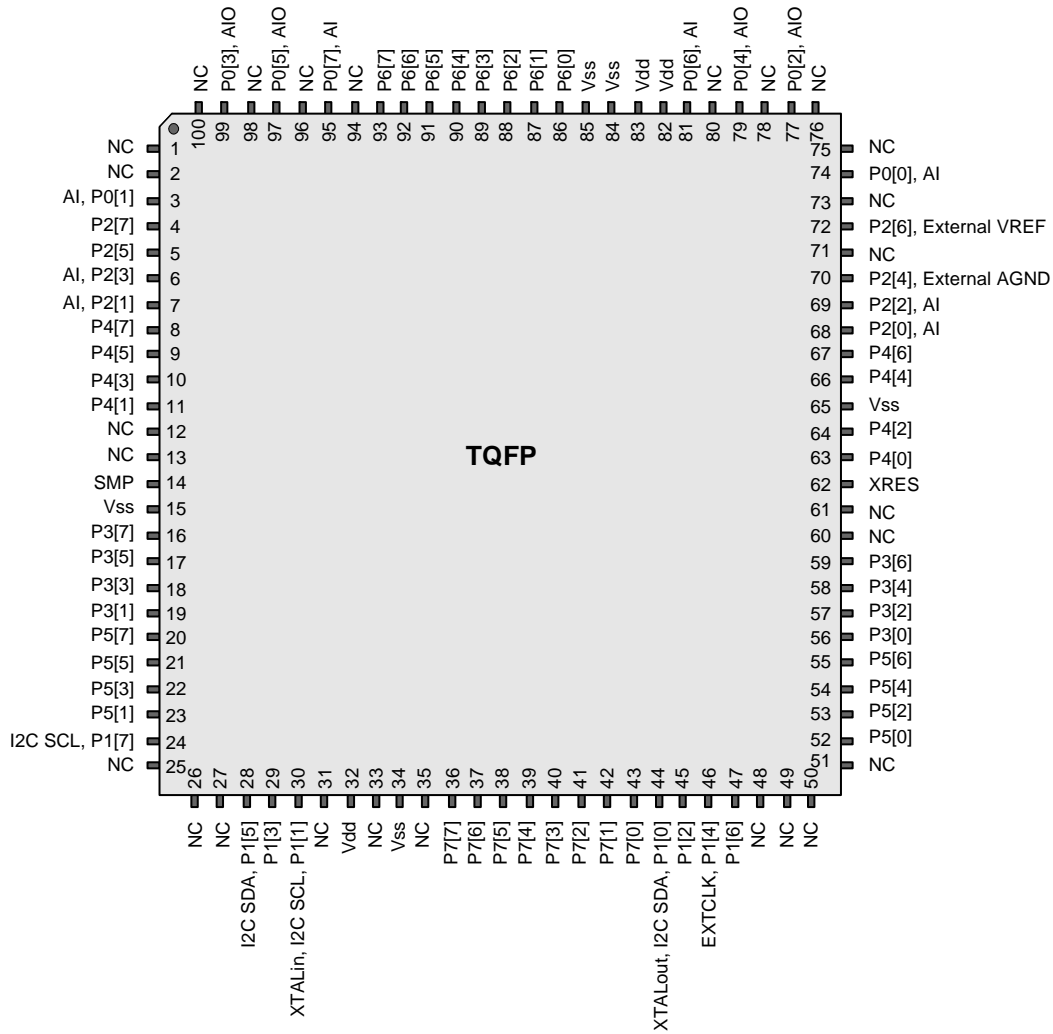

The 100-pin OCD part for the CY8CPLC20, CY8CLED16P01, and CY8C29x66 (CY8C29000) follows.

Note OCD parts are only used for in-circuit debugging. OCD parts are NOT available for production.

Table 1-20. 100-Pin OCD Part Pinout (TQFP)

Pin No.	Digital	Analog	Name	Description	Pin No.	Digital	Analog	Name	Description
1			NC	No internal connection.	51			NC	No internal connection.
2			NC	No internal connection.	52	IO		P5[0]	
3	IO	I	P0[1]	Analog column mux input.	53	IO		P5[2]	
4	IO		P2[7]		54	IO		P5[4]	
5	IO		P2[5]		55	IO		P5[6]	
6	IO	I	P2[3]	Direct switched capacitor block input.	56	IO		P3[0]	
7	IO	I	P2[1]	Direct switched capacitor block input.	57	IO		P3[2]	
8	IO		P4[7]		58	IO		P3[4]	
9	IO		P4[5]		59	IO		P3[6]	
10	IO		P4[3]		60			HCLK	OCD high speed clock output.
11	IO		P4[1]		61			CCLK	OCD CPU clock output.
12			OCDE	OCD even data IO.	62		Input	XRES	Active high pin reset with internal pull down.
13			OCDO	OCD odd data output.	63	IO		P4[0]	
14	Power		SMP	Switch Mode Pump (SMP) connection to required external components.	64	IO		P4[2]	
15	Power		Vss	Ground connection.	65	Power		Vss	Ground connection.
16	IO		P3[7]		66	IO		P4[4]	
17	IO		P3[5]		67	IO		P4[6]	
18	IO		P3[3]		68	IO	I	P2[0]	Direct switched capacitor block input.
19	IO		P3[1]		69	IO	I	P2[2]	Direct switched capacitor block input.
20	IO		P5[7]		70	IO		P2[4]	External Analog Ground (AGND) input.
21	IO		P5[5]		71			NC	No internal connection.
22	IO		P5[3]		72	IO		P2[6]	External Voltage Reference (VREF) input.
23	IO		P5[1]		73			NC	No internal connection.
24	IO		P1[7]	I2C Serial Clock (SCL).	74	IO	I	P0[0]	Analog column mux input.
25			NC	No internal connection.	75			NC	No internal connection.
26			NC	No internal connection.	76			NC	No internal connection.
27			NC	No internal connection.	77	IO	IO	P0[2]	Analog column mux input and column output.
28	IO		P1[5]	I2C Serial Data (SDA).	78			NC	No internal connection.
29	IO		P1[3]		79	IO	IO	P0[4]	Analog column mux input and column output.
30	IO		P1[1]*	Crystal (XTALin), I2C Serial Clock (SCL).	80			NC	No internal connection.
31			NC	No internal connection.	81	IO	I	P0[6]	Analog column mux input.
32	Power		Vdd	Supply voltage.	82	Power		Vdd	Supply voltage.
33			NC	No internal connection.	83	Power		Vdd	Supply voltage.
34	Power		Vss	Ground connection.	84	Power		Vss	Ground connection.
35			NC	No internal connection.	85	Power		Vss	Ground connection.
36	IO		P7[7]		86	IO		P6[0]	
37	IO		P7[6]		87	IO		P6[1]	
38	IO		P7[5]		88	IO		P6[2]	
39	IO		P7[4]		89	IO		P6[3]	
40	IO		P7[3]		90	IO		P6[4]	
41	IO		P7[2]		91	IO		P6[5]	
42	IO		P7[1]		92	IO		P6[6]	
43	IO		P7[0]		93	IO		P6[7]	
44	IO		P1[0]*	Crystal (XTALout), I2C Serial Data (SDA).	94			NC	No internal connection.
45	IO		P1[2]		95	IO	I	P0[7]	Analog column mux input.
46	IO		P1[4]	Optional External Clock Input (EXTCLK).	96			NC	No internal connection.
47	IO		P1[6]		97	IO	IO	P0[5]	Analog column mux input and column output.
48			NC	No internal connection.	98			NC	No internal connection.
49			NC	No internal connection.	99	IO	IO	P0[3]	Analog column mux input and column output.
50			NC	No internal connection.	100			NC	No internal connection.

LEGEND A = Analog, I = Input, O = Output, NC = No Connection.
 * ISSP pin, which is not High Z at POR.

CY8CPLC20, CY8CLEDP01, and CY8C29000 OCD PSoC Device

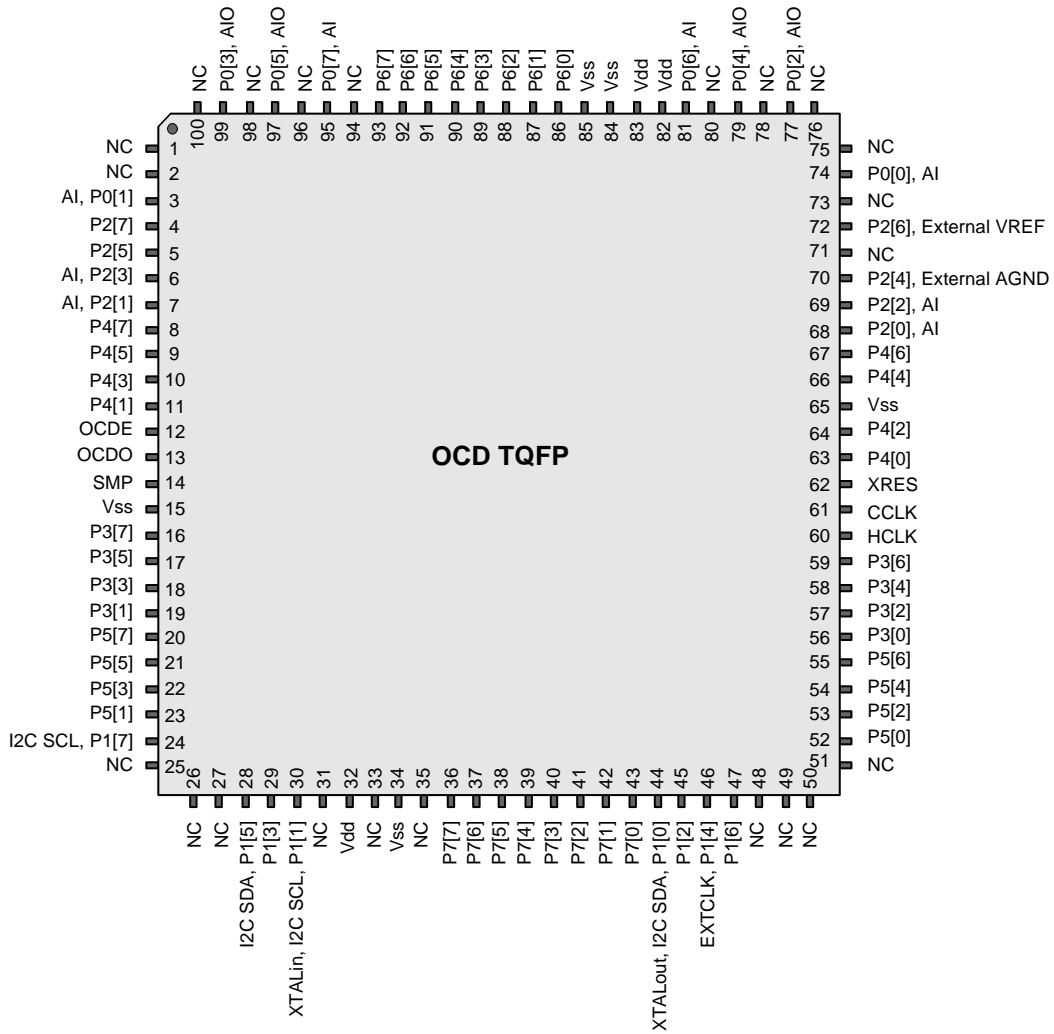

NOT FOR PRODUCTION

The 100-pin OCD part for the CY8C24x94 (CY8C24094) follows.

Note OCD parts are only used for in-circuit debugging. OCD parts are NOT available for production.

Table 1-21. 100-Pin OCD Part Pinout (TQFP)

Pin No.	Digital	Analog	Name	Description	Pin No.	Digital	Analog	Name	Description
1			NC	No internal connection.	51	IO	M	P1[6]	
2			NC	No internal connection.	52	IO	M	P5[0]	
3	IO	I,M	P0[1]	Analog column mux input.	53	IO	M	P5[2]	
4	IO	M	P2[7]		54	IO	M	P5[4]	
5	IO	M	P2[5]		55	IO	M	P5[6]	
6	IO	I,M	P2[3]	Direct switched capacitor block input.	56	IO	M	P3[0]	
7	IO	I,M	P2[1]	Direct switched capacitor block input.	57	IO	M	P3[2]	
8	IO	M	P4[7]		58	IO	M	P3[4]	
9	IO	M	P4[5]		59	IO	M	P3[6]	
10	IO	M	P4[3]		60			HCLK	OCD high speed clock output.
11	IO	M	P4[1]		61			CCLK	OCD CPU clock output.
12			OCDE	OCD even data IO.	62			XRES	Active high pin reset with internal pull down.
13			OCDO	OCD odd data output.	63	IO	M	P4[0]	
14			NC	No internal connection.	64	IO	M	P4[2]	
15	Power		Vss	Ground connection.	65	Power		Vss	Ground connection.
16	IO	M	P3[7]		66	IO	M	P4[4]	
17	IO	M	P3[5]		67	IO	M	P4[6]	
18	IO	M	P3[3]		68	IO	I,M	P2[0]	Direct switched capacitor block input.
19	IO	M	P3[1]		69	IO	I,M	P2[2]	Direct switched capacitor block input.
20	IO	M	P5[7]		70	IO	M	P2[4]	External Analog Ground (AGND) input.
21	IO	M	P5[5]		71			NC	No internal connection.
22	IO	M	P5[3]		72	IO	M	P2[6]	External Voltage Reference (VREF) input.
23	IO	M	P5[1]		73			NC	No internal connection.
24	IO	M	P1[7]	I2C Serial Clock (SCL).	74	IO	I,M	P0[0]	Analog column mux input.
25			NC	No internal connection.	75			NC	No internal connection.
26			NC	No internal connection.	76			NC	No internal connection.
27			NC	No internal connection.	77	IO	I,M	P0[2]	Analog column mux input.
28	IO	M	P1[5]	I2C Serial Data (SDA).	78			NC	No internal connection.
29	IO	M	P1[3]		79	IO	I,M	P0[4]	Analog column mux input.
30	IO	M	P1[1]*	I2C Serial Clock (SCL).	80			NC	No internal connection.
31			NC	No internal connection.	81	IO	I,M	P0[6]	Analog column mux input.
32	Power		Vss	Ground connection.	82	Power		Vdd	Supply voltage.
33	USB		D+		83			NC	No internal connection.
34	USB		D-		84	Power		Vss	Ground connection.
35	Power		Vdd	Supply voltage.	85			NC	No internal connection.
36	IO		P7[7]		86			NC	No internal connection.
37	IO		P7[6]		87			NC	No internal connection.
38	IO		P7[5]		88			NC	No internal connection.
39	IO		P7[4]		89			NC	No internal connection.
40	IO		P7[3]		90			NC	No internal connection.
41	IO		P7[2]		91			NC	No internal connection.
42	IO		P7[1]		92			NC	No internal connection.
43	IO		P7[0]		93			NC	No internal connection.
44			NC	No internal connection.	94			NC	No internal connection.
45			NC	No internal connection.	95	IO	I,M	P0[7]	Analog column mux input.
46			NC	No internal connection.	96			NC	No internal connection.
47			NC	No internal connection.	97	IO	I,M	P0[5]	Analog column mux input and column output.
48	IO	M	P1[0]*	I2C Serial Data (SDA).	98			NC	No internal connection.
49	IO	M	P1[2]		99	IO	I,M	P0[3]	Analog column mux input and column output.
50	IO	M	P1[4]		100			NC	No internal connection.

LEGEND A = Analog, I = Input, O = Output, and M = Analog Mux Input.
 * ISSP pin, which is not High Z at POR.

CY8C24094 OCD PSoC Device

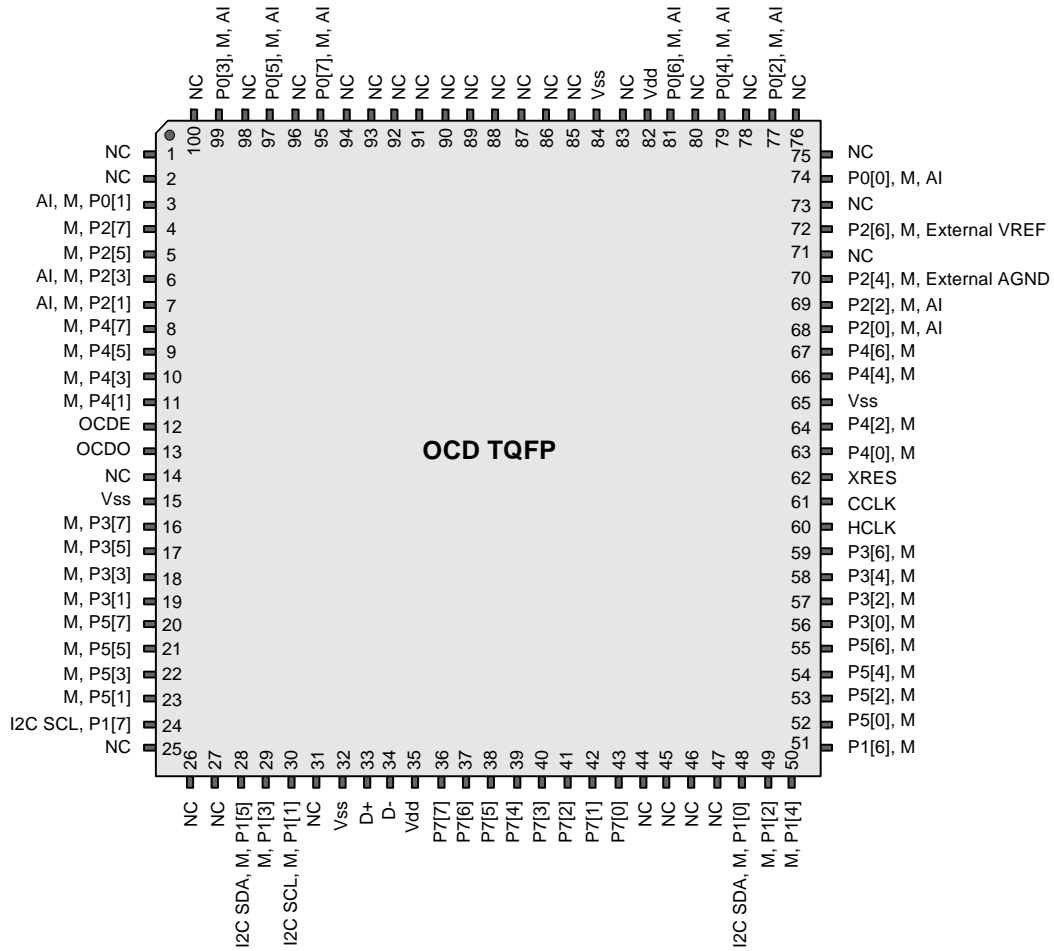

The 100-pin TQFP part for the CY8CNP1xx (CY8CNP101, CY8CNP102, CY8CNP112) follows.

Table 1-22. 100-Pin TQFP Part Pinout

Pin No.	Digital	Analog	Name	Description	Pin No.	Digital	Analog	Name	Description
1	IO	IO	P0[5]	Analog Column Mux Input and Column Output	51	IO		P1[0]	Serial Data (SDA), Crystal (XTALout), GPIO
2	IO	IO	P0[3]	Analog Column Mux Input and Column Output	52	IO		P1[2]	GPIO
3	IO	I	P0[1]	Analog Column Mux Input, GPIO	53	IO		P1[4]	GPIO
4	IO		P2[7]	GPIO	54	IO		P5[0]	GPIO
5	IO		P2[5]	GPIO	55	IO		P5[2]	GPIO
6	IO	I	P2[3]	Direct Switched Capacitor Block Input	56	IO		P5[4]	GPIO
7	IO	I	P2[1]	Direct Switched Capacitor Block Input	57	IO		P5[6]	GPIO
8	Power		Vcc	Supply Voltage	58			EN_A1	Connect to Pin 49 (EN_A1 to NV_A1)
9			DNU	Reserved for test modes - Do Not Use	59			EN_A2	Connect to Pin 50 (EN_A2 to NV_A2)
10			DNU	Reserved for test modes - Do Not Use	60			EN_O	Connect to Pin 76 (EN_O to NV_O)
11			DNU	Reserved for test modes - Do Not Use	61			EN_C	Connect to Pin 99 (EN_C to NV_C)
12			DNU	Reserved for test modes - Do Not Use	62	Input		XRES	Active high external reset (Internal Pull down)
13			DNU	Reserved for test modes - Do Not Use	63	Power		VCAP	External Capacitor connection for nvSRAM
14			NC	No internal connection.	64	Power		Vcc	Supply Voltage
15	IO		P3[5]	GPIO	65	IO	I	P2[0]	Direct Switched Capacitor Block Input, GPIO
16			EN_W	Connect to Pin 26 (EN_W to NV_W)	66	IO	I	P2[2]	Direct Switched Capacitor Block Input, GPIO
17	IO		P3[1]	GPIO	67	IO		P2[4]	External Analog GND, GPIO
18	IO		P5[7]	GPIO	68	IO		P2[6]	External Voltage Ref, GPIO
19	IO		P5[5]	GPIO	69	IO	I	P0[0]	Analog Column Mux Input, GPIO
20	IO		P5[3]	GPIO	70	IO	IO	P0[2]	Analog Column Mux Input and Column Output
21	IO		P5[1]	GPIO	71	IO	IO	P0[4]	Analog Column Mux Input and Column Output
22	IO		P1[7]	I2C Serial Clock (SCL), GPIO	72			NC	No internal connection.
23	IO		P1[5]	I2C Serial Data (SDA), GPIO	73			NC	No internal connection.
24	IO		P1[3]	GPIO	74	IO	I	P0_6	Analog Column Mux Input, GPIO
25	IO		P1[1]	Serial Clock (SCL), Crystal (XTALin), GPIO	75	Power		Vcc	Supply Voltage
26			NV_W	Connect to pin 16 (NV_W to EN_W)	76			NV_O	Connect to Pin 60 (NV_O to EN_O)
27			NC	No internal connection.	77			DNU	Reserved for test modes - Do Not Use
28			NC	No internal connection.	78			NC	Not connected on the die
29			NC	No internal connection.	79			HSB#	Internal Weak Pull up. Connect 10kΩ to Vcc.
30			NC	No internal connection.	80	Power		Vcc	Supply Voltage
31			NC	No internal connection.	81			NC	No internal connection.
32			NC	No internal connection.	82			NC	No internal connection.
33			NC	No internal connection.	83			NC	No internal connection.
34			NC	No internal connection.	84			NC	No internal connection.
35	Power		Vss	Ground	85			NC	No internal connection.
36	Power		Vss	Ground	86	Power		Vss	Ground
37	Power		Vss	Ground	87	Power		Vss	Ground
38	Power		Vss	Ground	88	Power		Vss	Ground
39	Power		Vss	Ground	89	Power		Vss	Ground
40			NC	No internal connection.	90	Power		Vss	Ground
41			NC	No internal connection.	91			NC	No internal connection.
42			NC	No internal connection.	92			NC	No internal connection.
43			NC	No internal connection.	93			NC	No internal connection.
44			NC	No internal connection.	94			NC	No internal connection.
45			NC	No internal connection.	95			NC	No internal connection.
46			NC	No internal connection.	96			NC	No internal connection.
47			NC	No internal connection.	97			NC	No internal connection.
48			DNU	Reserved for test modes - Do Not Use	98			NC	No internal connection.
49			NV_A1	Connect to pin 58 (NV_A1 to EN_A1)	99			NV_C	Connect to pin 61 (NV_C to EN_C)
50			NV_A2	Connect to pin 59 (NV_A2 to EN_A2)	100	IO	I	P0[7]	Analog Column Mux Input, GPIO

LEGEND A = Analog, I = Input, O = Output, and M = Analog Mux Input.
 * ISSP pin, which is not High Z at POR.

CY8CNP1xx TQFP PSoC Device

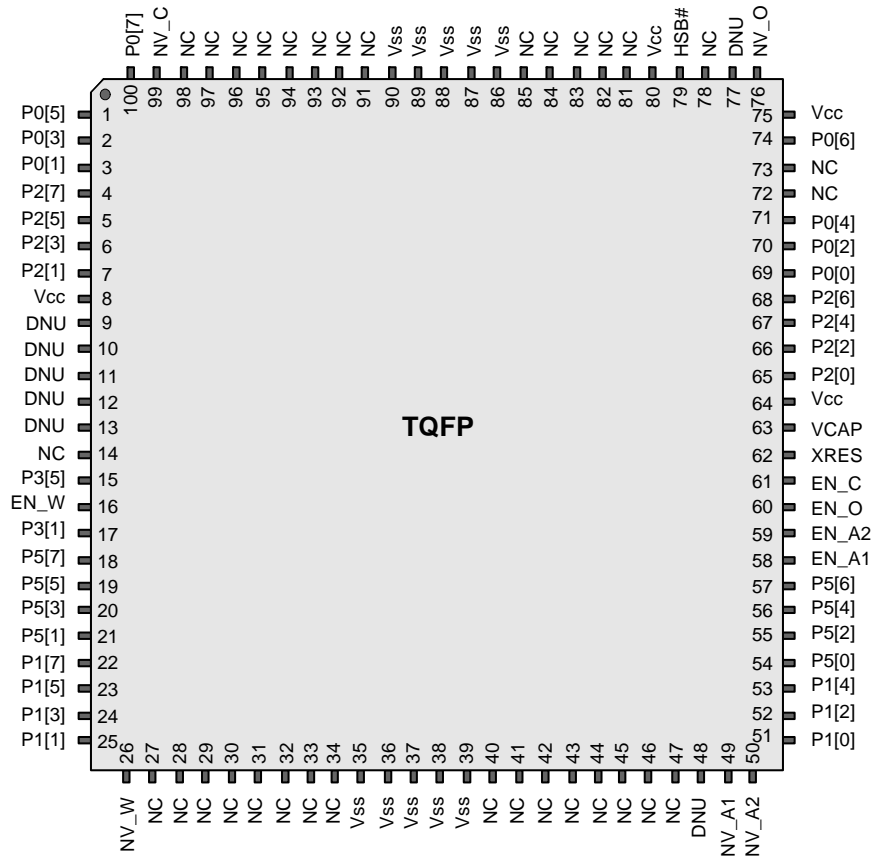

1.1.12 VFBGA Part Pinouts

The 100-ball VFBGA part is for the CY8C24994 PSoC device. The table and drawing for the VFBGA OCD part for the CY8C24094 follows.

Table 1-23. 100-Ball Part Pinout (VFBGA)

Pin No.	Digital	Analog	Name	Description	Pin No.	Digital	Analog	Name	Description
A1	Power		Vss	Ground connection.	F1			NC	No internal connection.
A2	Power		Vss	Ground connection.	F2	IO	M	P5[7]	
A3			NC	No internal connection.	F3	IO	M	P3[5]	
A4			NC	No internal connection.	F4	IO	M	P5[1]	
A5			NC	No internal connection.	F5	Power		Vss	Ground connection.
A6	Power		Vdd	Supply voltage.	F6	Power		Vss	Ground connection.
A7			NC	No internal connection.	F7	IO	M	P5[0]	
A8			NC	No internal connection.	F8	IO	M	P3[0]	
A9	Power		Vss	Ground connection.	F9			XRES	Active high pin reset with internal pull down.
A10	Power		Vss	Ground connection.	F10	IO		P7[1]	
B1	Power		Vss	Ground connection.	G1			NC	No internal connection.
B2	Power		Vss	Ground connection.	G2	IO	M	P5[5]	
B3	IO	I,M	P2[1]	Direct switched capacitor block input.	G3	IO	M	P3[3]	
B4	IO	I,M	P0[1]	Analog column mux input.	G4	IO	M	P1[7]	I2C Serial Clock (SCL).
B5	IO	I,M	P0[7]	Analog column mux input.	G5	IO	M	P1[1]*	I2C Serial Clock (SCL).
B6	Power		Vdd	Supply voltage.	G6	IO	M	P1[0]*	I2C Serial Data (SDA).
B7	IO	I,M	P0[2]	Analog column mux input.	G7	IO	M	P1[6]	
B8	IO	I,M	P2[2]	Direct switched capacitor block input.	G8	IO	M	P3[4]	
B9	Power		Vss	Ground connection.	G9	IO	M	P5[6]	
B10	Power		Vss	Ground connection.	G10	IO		P7[2]	
C1			NC	No internal connection.	H1			NC	No internal connection.
C2	IO	M	P4[1]		H2	IO	M	P5[3]	
C3	IO	M	P4[7]		H3	IO	M	P3[1]	
C4	IO	M	P2[7]		H4	IO	M	P1[5]	I2C Serial Data (SDA).
C5	IO	I,M	P0[5]	Analog column mux input and column output.	H5	IO	M	P1[3]	
C6	IO	I,M	P0[6]	Analog column mux input.	H6	IO	M	P1[2]	
C7	IO	I,M	P0[0]	Analog column mux input.	H7	IO	M	P1[4]	
C8	IO	I,M	P2[0]	Direct switched capacitor block input.	H8	IO	M	P3[2]	
C9	IO	M	P4[2]		H9	IO	M	P5[4]	
C10			NC	No internal connection.	H10	IO		P7[3]	
D1			NC	No internal connection.	J1	Power		Vss	Ground connection.
D2	IO	M	P3[7]		J2	Power		Vss	Ground connection.
D3	IO	M	P4[5]		J3	USB		D+	
D4	IO	M	P2[5]		J4	USB		D-	
D5	IO	I,M	P0[3]	Analog column mux input and column output.	J5	Power		Vdd	Supply voltage.
D6	IO	I,M	P0[4]	Analog column mux input.	J6	IO		P7[7]	
D7	IO	M	P2[6]	External Voltage Reference (VREF) input.	J7	IO		P7[0]	
D8	IO	M	P4[6]		J8	IO	M	P5[2]	
D9	IO	M	P4[0]		J9	Power		Vss	Ground connection.
D10			NC	No internal connection.	J10	Power		Vss	Ground connection.
E1			NC	No internal connection.	K1	Power		Vss	Ground connection.
E2			NC	No internal connection.	K2	Power		Vss	Ground connection.
E3	IO	M	P4[3]		K3			NC	No internal connection.
E4	IO	I,M	P2[3]	Direct switched capacitor block input.	K4			NC	No internal connection.
E5	Power		Vss	Ground connection.	K5	Power		Vdd	Supply voltage.
E6	Power		Vss	Ground connection.	K6	IO		P7[6]	
E7	IO	M	P2[4]	External Analog Ground (AGND) input.	K7	IO		P7[5]	
E8	IO	M	P4[4]		K8	IO		P7[4]	
E9	IO	M	P3[6]		K9	Power		Vss	Ground connection.
E10			NC	No internal connection.	K10	Power		Vss	Ground connection.

LEGEND A = Analog, I = Input, O = Output, M = Analog Mux Input, NC = No Connection.

* ISSP pin, which is not High Z at POR.

VFBGA CY8C24994 PSoC Device

	1	2	3	4	5	6	7	8	9	10
A	Vss	Vss	NC	NC	NC	Vdd	NC	NC	Vss	Vss
B	Vss	Vss	P2[1]	P0[1]	P0[7]	Vdd	P0[2]	P2[2]	Vss	Vss
C	NC	P4[1]	P4[7]	P2[7]	P0[5]	P0[6]	P0[0]	P2[0]	P4[2]	NC
D	NC	P3[7]	P4[5]	P2[5]	P0[3]	P0[4]	P2[6]	P4[6]	P4[0]	NC
E	NC	NC	P4[3]	P2[3]	Vss	Vss	P2[4]	P4[4]	P3[6]	NC
F	NC	P5[7]	P3[5]	P5[1]	Vss	Vss	P5[0]	P3[0]	XRES	P7[1]
G	NC	P5[5]	P3[3]	P1[7]	P1[1]	P1[0]	P1[6]	P3[4]	P5[6]	P7[2]
H	NC	P5[3]	P3[1]	P1[5]	P1[3]	P1[2]	P1[4]	P3[2]	P5[4]	P7[3]
J	Vss	Vss	D +	D -	Vdd	P7[7]	P7[0]	P5[2]	Vss	Vss
K	Vss	Vss	NC	NC	Vdd	P7[6]	P7[5]	P7[4]	Vss	Vss

BGA (Top View)

The 100-ball VFBGA OCD part for the CY8C24x94 (CY8C24094) follows.

Note OCD parts are only used for in-circuit debugging. OCD parts are NOT available for production.

Table 1-24. 100-Ball Part Pinout (VFBGA)

Pin No.	Digital	Analog	Name	Description	Pin No.	Digital	Analog	Name	Description
A1	Power		Vss	Ground connection.	F1			OCDE	OCD even data IO.
A2	Power		Vss	Ground connection.	F2	IO	M	P5[7]	
A3			NC	No internal connection.	F3	IO	M	P3[5]	
A4			NC	No internal connection.	F4	IO	M	P5[1]	
A5			NC	No internal connection.	F5	Power		Vss	Ground connection.
A6	Power		Vdd	Supply voltage.	F6	Power		Vss	Ground connection.
A7			NC	No internal connection.	F7	IO	M	P5[0]	
A8			NC	No internal connection.	F8	IO	M	P3[0]	
A9	Power		Vss	Ground connection.	F9			XRES	Active high pin reset with internal pull down.
A10	Power		Vss	Ground connection.	F10	IO		P7[1]	
B1	Power		Vss	Ground connection.	G1			OCDO	OCD odd data output.
B2	Power		Vss	Ground connection.	G2	IO	M	P5[5]	
B3	IO	I,M	P2[1]	Direct switched capacitor block input.	G3	IO	M	P3[3]	
B4	IO	I,M	P0[1]	Analog column mux input.	G4	IO	M	P1[7]	I2C Serial Clock (SCL).
B5	IO	I,M	P0[7]	Analog column mux input.	G5	IO	M	P1[1]*	I2C Serial Clock (SCL).
B6	Power		Vdd	Supply voltage.	G6	IO	M	P1[0]*	I2C Serial Data (SDA).
B7	IO	I,M	P0[2]	Analog column mux input.	G7	IO	M	P1[6]	
B8	IO	I,M	P2[2]	Direct switched capacitor block input.	G8	IO	M	P3[4]	
B9	Power		Vss	Ground connection.	G9	IO	M	P5[6]	
B10	Power		Vss	Ground connection.	G10	IO		P7[2]	
C1			NC	No internal connection.	H1			NC	No internal connection.
C2	IO	M	P4[1]		H2	IO	M	P5[3]	
C3	IO	M	P4[7]		H3	IO	M	P3[1]	
C4	IO	M	P2[7]		H4	IO	M	P1[5]	I2C Serial Data (SDA).
C5	IO	I,M	P0[5]	Analog column mux input and column output.	H5	IO	M	P1[3]	
C6	IO	I,M	P0[6]	Analog column mux input.	H6	IO	M	P1[2]	
C7	IO	I,M	P0[0]	Analog column mux input.	H7	IO	M	P1[4]	
C8	IO	I,M	P2[0]	Direct switched capacitor block input.	H8	IO	M	P3[2]	
C9	IO	M	P4[2]		H9	IO	M	P5[4]	
C10			NC	No internal connection.	H10	IO		P7[3]	
D1			NC	No internal connection.	J1	Power		Vss	Ground connection.
D2	IO	M	P3[7]		J2	Power		Vss	Ground connection.
D3	IO	M	P4[5]		J3	USB		D+	
D4	IO	M	P2[5]		J4	USB		D-	
D5	IO	I,M	P0[3]	Analog column mux input and column output.	J5	Power		Vdd	Supply voltage.
D6	IO	I,M	P0[4]	Analog column mux input.	J6	IO		P7[7]	
D7	IO	M	P2[6]	External Voltage Reference (VREF) input.	J7	IO		P7[0]	
D8	IO	M	P4[6]		J8	IO	M	P5[2]	
D9	IO	M	P4[0]		J9	Power		Vss	Ground connection.
D10			CCLK	OCD CPU clock output.	J10	Power		Vss	Ground connection.
E1			NC	No internal connection.	K1	Power		Vss	Ground connection.
E2			NC	No internal connection.	K2	Power		Vss	Ground connection.
E3	IO	M	P4[3]		K3			NC	No internal connection.
E4	IO	I,M	P2[3]	Direct switched capacitor block input.	K4			NC	No internal connection.
E5	Power		Vss	Ground connection.	K5	Power		Vdd	Supply voltage.
E6	Power		Vss	Ground connection.	K6	IO		P7[6]	
E7	IO	M	P2[4]	External Analog Ground (AGND) input.	K7	IO		P7[5]	
E8	IO	M	P4[4]		K8	IO		P7[4]	
E9	IO	M	P3[6]		K9	Power		Vss	Ground connection.
E10			HCLK	OCD high speed clock output.	K10	Power		Vss	Ground connection.

LEGEND A = Analog, I = Input, O = Output, M = Analog Mux Input, NC = No Connection.
 * ISSP pin, which is not High Z at POR.

VFBGA OCD CY8C24094 PSoC Device

	1	2	3	4	5	6	7	8	9	10
A	Vss	Vss	NC	NC	NC	Vdd	NC	NC	Vss	Vss
B	Vss	Vss	P2[1]	P0[1]	P0[7]	Vdd	P0[2]	P2[2]	Vss	Vss
C	NC	P4[1]	P4[7]	P2[7]	P0[5]	P0[6]	P0[0]	P2[0]	P4[2]	NC
D	NC	P3[7]	P4[5]	P2[5]	P0[3]	P0[4]	P2[6]	P4[6]	P4[0]	CClk
E	NC	NC	P4[3]	P2[3]	Vss	Vss	P2[4]	P4[4]	P3[6]	HClk
F	ocde	P5[7]	P3[5]	P5[1]	Vss	Vss	P5[0]	P3[0]	XRES	P7[1]
G	ocdo	P5[5]	P3[3]	P1[7]	P1[1]	P1[0]	P1[6]	P3[4]	P5[6]	P7[2]
H	NC	P5[3]	P3[1]	P1[5]	P1[3]	P1[2]	P1[4]	P3[2]	P5[4]	P7[3]
J	Vss	Vss	D +	D -	Vdd	P7[7]	P7[0]	P5[2]	Vss	Vss
K	Vss	Vss	NC	NC	Vdd	P7[6]	P7[5]	P7[4]	Vss	Vss

BGA (Top View)

NOT FOR PRODUCTION

Section B: PSoC Core



The PSoC Core section discusses the core components of a PSoC device with a base part number of CY8C2xxxx (except for the CY8C25122 and CY8C26xxx PSoC devices) and the registers associated with those components. It also applies to CY7C64215, CY7C603xx, CY8CNP1xx, and CYWUSB6953. Note that there are no analog output drivers for the CY8C21x34, CY8C21x23, CY7C603xx, and CYWUSB6953 PSoC devices, and there is no ECO or PLL for the CY8C24x94, CY8C21x34, CY8C21x23, CY7C64215, CY7C603xx, and CYWUSB6953 PSoC devices. This section encompasses the following chapters:

- CPU Core (M8C) on page 63
- Supervisory ROM (SRAM) on page 73
- RAM Paging on page 85
- Interrupt Controller on page 95
- General Purpose IO (GPIO) on page 103
- Analog Output Drivers on page 111
- Internal Main Oscillator (IMO) on page 113
- Internal Low Speed Oscillator (ILO) on page 117
- External Crystal Oscillator (ECO) on page 119
- Phase-Locked Loop (PLL) on page 125
- Sleep and Watchdog on page 129

Top Level Core Architecture

The figure below displays the top level architecture of the PSoC's core. Each component of the figure is discussed at length in this section.

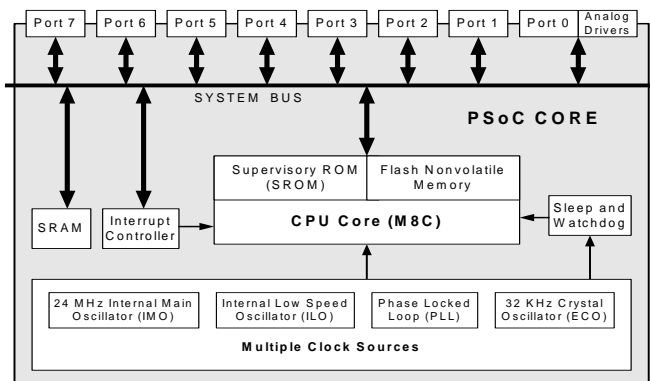

PSoC Core Block Diagram

Interpreting the Core Documentation

The core section covers the heart of the PSoC device which includes the M8C **microcontroller**, SRAM, interrupt controller, GPIO, analog output drivers, and **SRAM** paging; multiple clock sources such as IMO, ILO, ECO, and PLL; and sleep and watchdog functionality.

The **analog output** drivers are described in this section and not the Analog System section because they are part of the PSoC core input and **output** signals.

Core Register Summary

The table below lists all the PSoC registers for the CPU core in **address** order within their system resource configuration. The bits that are grayed out are reserved bits. If these bits are written, they should always be written with a value of '0'. For the core registers, the first 'x' in some **register** addresses represents either bank 0 or bank 1. These registers are listed throughout this manual in bank 0, even though they are also available in bank 1.

Note that all PSoC devices have a combination of 4, 2, or 1 analog columns and 4, 2 or 1 digital rows. The registers that are specifically constrained by the number of analog columns have the number of analog columns (Cols.) listed within the Address column of the table. The registers specifically pertaining to digital rows have the number of rows (Rows) listed within the Address column of the table. To determine the number of analog columns and digital rows in your PSoC device, refer to the table titled "PSoC Device Characteristics" on page 22.

Summary Table of the Core Registers

Address	Name	Bit 7	Bit 6	Bit 5	Bit 4	Bit 3	Bit 2	Bit 1	Bit 0	Access	
M8C REGISTER (page 72)											
x,F7h	CPU_F	PgMode[1:0]			XIO		Carry	Zero	GIE	RL : 02	
SUPERVISORY ROM (SRAM) REGISTERS (page 78)											
0,D1h	STK_PP						Page Bits[2:0]			RW : 00	
0,D4h	MVR_PP						Page Bits[2:0]			RW : 00	
0,D5h	MVW_PP						Page Bits[2:0]			RW : 00	
x,FEh	CPU_SCR1	IRESS		SLIMO	ECO EXW	ECO EX			IRAMDIS	# : 00	
1,FAh	FLS_PR1							Bank[1:0]		RW:00	
RAM PAGING (SRAM) REGISTERS (page 89)											
x,6Ch	TMP_DR0	Data[7:0]								RW : 00	
x,6Dh	TMP_DR1	Data[7:0]								RW : 00	
x,6Eh	TMP_DR2	Data[7:0]								RW : 00	
x,6Fh	TMP_DR3	Data[7:0]								RW : 00	
0,D0h	CUR_PP						Page Bits[2:0]			RW : 00	
0,D1h	STK_PP						Page Bits[2:0]			RW : 00	
0,D3h	IDX_PP						Page Bits[2:0]			RW : 00	
0,D4h	MVR_PP						Page Bits[2:0]			RW : 00	
0,D5h	MVW_PP						Page Bits[2:0]			RW : 00	
x,F7h	CPU_F	PgMode[1:0]			XIO		Carry	Zero	GIE	RL : 02	
INTERRUPT CONTROLLER REGISTERS (page 98)											
0,DAh 4 Cols. 2 Cols. 1 Col.	INT_CLR0	VC3	Sleep	GPIO	Analog 3	Analog 2	Analog 1	Analog 0	V Monitor	RW : 00	
		VC3	Sleep	GPIO			Analog 1	Analog 0	V Monitor		
		VC3	Sleep	GPIO			Analog 1		V Monitor		
0,DBh 4, 2 Rows 1 Row	INT_CLR1	DCB13	DCB12	DBB11	DBB10	DCB03	DCB02	DBB01	DBB00	RW : 00	
0,DCh 4 Rows	INT_CLR2	DCB33	DCB32	DBB31	DBB30	DCB23	DCB22	DBB21	DBB20	RW : 00	
0,DDh	INT_CLR3								I2C	RW : 00	
0,DEh	INT_MSK3	ENSWINT								I2C	RW : 00
0,DFh 4 Rows	INT_MSK2	DCB33	DCB32	DBB31	DBB30	DCB23	DCB22	DBB21	DBB20	RW : 00	
0,E0h 4 Cols. 2 Cols. 1 Col.	INT_MSK0	VC3	Sleep	GPIO	Analog 3	Analog 2	Analog 1	Analog 0	V Monitor	RW : 00	
		VC3	Sleep	GPIO			Analog 1	Analog 0	V Monitor		
		VC3	Sleep	GPIO			Analog 1		V Monitor		
0,E1h 4, 2 Rows 1 Row	INT_MSK1	DCB13	DCB12	DBB11	DBB10	DCB03	DCB02	DBB01	DBB00	RW : 00	
0,E2h	INT_VC	Pending Interrupt[7:0]								RC : 00	
x,F7h	CPU_F	PgMode[1:0]			XIO		Carry	Zero	GIE	RL : 02	
GENERAL PURPOSE IO (GPIO) REGISTERS (page 107)											
0,00h	PRT0DR	Data[7:0]								RW : 00	

Summary Table of the Core Registers (*continued*)

Address	Name	Bit 7	Bit 6	Bit 5	Bit 4	Bit 3	Bit 2	Bit 1	Bit 0	Access
0,01h	PRT0IE	Interrupt Enables[7:0]								RW : 00
0,02h	PRT0GS	Global Select[7:0]								RW : 00
0,03h	PRT0DM2	Drive Mode 2[7:0]								RW : FF
1,00h	PRT0DM0	Drive Mode 0[7:0]								RW : 00
1,01h	PRT0DM1	Drive Mode 1[7:0]								RW : FF
1,02h	PRT0IC0	Interrupt Control 0[7:0]								RW : 00
1,03h	PRT0IC1	Interrupt Control 1[7:0]								RW : 00
0,04h	PRT1DR	Data[7:0]								RW : 00
0,05h	PRT1IE	Interrupt Enables[7:0]								RW : 00
0,06h	PRT1GS	Global Select[7:0]								RW : 00
0,07h	PRT1DM2	Drive Mode 2[7:0]								RW : FF
1,04h	PRT1DM0	Drive Mode 0[7:0]								RW : 00
1,05h	PRT1DM1	Drive Mode 1[7:0]								RW : FF
1,06h	PRT1IC0	Interrupt Control 0[7:0]								RW : 00
1,07h	PRT1IC1	Interrupt Control 1[7:0]								RW : 00
0,08h	PRT2DR	Data[7:0]								RW : 00
0,09h	PRT2IE	Interrupt Enables[7:0]								RW : 00
0,0Ah	PRT2GS	Global Select[7:0]								RW : 00
0,0Bh	PRT2DM2	Drive Mode 2[7:0]								RW : FF
1,08h	PRT2DM0	Drive Mode 0[7:0]								RW : 00
1,09h	PRT2DM1	Drive Mode 1[7:0]								RW : FF
1,0Ah	PRT2IC0	Interrupt Control 0[7:0]								RW : 00
1,0Bh	PRT2IC1	Interrupt Control 1[7:0]								RW : 00
0,0Ch	PRT3DR	Data[7:0]								RW : 00
0,0Dh	PRT3IE	Interrupt Enables[7:0]								RW : 00
0,0Eh	PRT3GS	Global Select[7:0]								RW : 00
0,0Fh	PRT3DM2	Drive Mode 2[7:0]								RW : FF
1,0Ch	PRT3DM0	Drive Mode 0[7:0]								RW : 00
1,0Dh	PRT3DM1	Drive Mode 1[7:0]								RW : FF
1,0Eh	PRT3IC0	Interrupt Control 0[7:0]								RW : 00
1,0Fh	PRT3IC1	Interrupt Control 1[7:0]								RW : 00
0,10h	PRT4DR	Data[7:0]								RW : 00
0,11h	PRT4IE	Interrupt Enables[7:0]								RW : 00
0,12h	PRT4GS	Global Select[7:0]								RW : 00
0,13h	PRT4DM2	Drive Mode 2[7:0]								RW : FF
1,10h	PRT4DM0	Drive Mode 0[7:0]								RW : 00
1,11h	PRT4DM1	Drive Mode 1[7:0]								RW : FF
1,12h	PRT4IC0	Interrupt Control 0[7:0]								RW : 00
1,13h	PRT4IC1	Interrupt Control 1[7:0]								RW : 00
0,14h	PRT5DR	Data[7:0]								RW : 00
0,15h	PRT5IE	Interrupt Enables[7:0]								RW : 00
0,16h	PRT5GS	Global Select[7:0]								RW : 00
0,17h	PRT5DM2	Drive Mode 2[7:0]								RW : FF
1,14h	PRT5DM0	Drive Mode 0[7:0]								RW : 00
1,15h	PRT5DM1	Drive Mode 1[7:0]								RW : FF
1,16h	PRT5IC0	Interrupt Control 0[7:0]								RW : 00
1,17h	PRT5IC1	Interrupt Control 1[7:0]								RW : 00
0,18h	PRT6DR	Data[7:0]								RW : 00
0,19h	PRT6IE	Interrupt Enables[7:0]								RW : 00
0,1Ah	PRT6GS	Global Select[7:0]								RW : 00
0,1Bh	PRT6DM2	Drive Mode 2[7:0]								RW : FF

Summary Table of the Core Registers (continued)

Address	Name	Bit 7	Bit 6	Bit 5	Bit 4	Bit 3	Bit 2	Bit 1	Bit 0	Access	
1,18h	PRT6DM0	Drive Mode 0[7:0]								RW : 00	
1,19h	PRT6DM1	Drive Mode 1[7:0]								RW : FF	
1,1Ah	PRT6IC0	Interrupt Control 0[7:0]								RW : 00	
1,1Bh	PRT6IC1	Interrupt Control 1[7:0]								RW : 00	
0,1Ch	PRT7DR	Data[7:0]								RW : 00	
0,1Dh	PRT7IE	Interrupt Enables[7:0]								RW : 00	
0,1Eh	PRT7GS	Global Select[7:0]								RW : 00	
0,1Fh	PRT7DM2	Drive Mode 2[7:0]								RW : FF	
1,1Ch	PRT7DM0	Drive Mode 0[7:0]								RW : 00	
1,1Dh	PRT7DM1	Drive Mode 1[7:0]								RW : FF	
1,1Eh	PRT7IC0	Interrupt Control 0[7:0]								RW : 00	
1,1Fh	PRT7IC1	Interrupt Control 1[7:0]								RW : 00	
ANALOG OUTPUT DRIVER REGISTER ** (page 112)											
1,62h	4 Cols. 2 Cols. 1 Col.	ABF_CR0	ACol1Mux	ACol2Mux	ABUF1EN	ABUF2EN	ABUF0EN	ABUF3EN	Bypass	PWR	RW : 00
			ACol1Mux		ABUF1EN		ABUF0EN		Bypass	PWR	
			ACol1Mux		ABUF1EN				Bypass	PWR	
INTERNAL MAIN OSCILLATOR (IMO) REGISTERS (page 115)											
x,FEh	CPU_SCR1	IRESS			SLIMO	ECO EXW	ECO EX		IRAMDIS	# : 00	
1,E2h	OSC_CR2	PLLGAIN					EXTCLKEN	IMODIS	SYSCLKX2 DIS	RW : 00	
1,E8h	IMO_TR	Trim[7:0]								W : 00	
INTERNAL LOW SPEED OSCILLATOR (ILO) REGISTER (page 117)											
1,E9h	ILO_TR			Bias Trim[1:0]			Freq Trim[3:0]			W : 00	
EXTERNAL CRYSTAL OSCILLATOR (ECO) REGISTERS (page 121)											
x,FEh	CPU_SCR1	IRESS			SLIMO	ECO EXW	ECO EX		IRAMDIS	# : 00	
1,E0h	OSC_CR0	32k Select	PLL Mode	No Buzz	Sleep[1:0]		CPU Speed[2:0]			RW : 00	
1,EBh	ECO_TR	PSSDC[1:0]								W : 00	
PHASE-LOCKED LOOP (PLL) REGISTERS (page 125)											
1,E0h	OSC_CR0	32k Select	PLL Mode	No Buzz	Sleep[1:0]		CPU Speed[2:0]			RW : 00	
1,E2h	OSC_CR2	PLLGAIN					EXTCLKEN	IMODIS	SYSCLKX2 DIS	RW : 00	
SLEEP AND WATCHDOG REGISTERS (page 131)											
0,E0h	4 Cols. 2 Cols. 1 Col.	INT_MSK0	VC3	Sleep	GPIO	Analog 3	Analog 2	Analog 1	Analog 0	V Monitor	RW : 00
			VC3	Sleep	GPIO			Analog 1	Analog 0	V Monitor	
			VC3	Sleep	GPIO			Analog 1		V Monitor	
0,E3h	RES_WDT	WDSL_Clear[7:0]								W : 00	
x,FEh	CPU_SCR1	IRESS			SLIMO	ECO EXW	ECO EX		IRAMDIS	# : 00	
x,FFh	CPU_SCR0	GIES		WDRS	PORS	Sleep			STOP	# : XX	
1,E0h	OSC_CR0	32k Select	PLL Mode	No Buzz	Sleep[1:0]		CPU Speed[2:0]			RW : 00	
1,E9h	ILO_TR			Bias Trim[1:0]			Freq Trim[3:0]			W : 00	
1,EBh	ECO_TR	PSSDC[1:0]								W : 00	

LEGEND

- L The and f, expr; or f, expr; and xor f, expr instructions can be used to modify this register.
- # Access is bit specific. Refer to the Register Details chapter on page 147 for additional information.
- X The value for power on reset is unknown.
- x An "x" before the comma in the address field indicates that this register can be accessed or written to no matter what bank is used.
- C Clearable register or bit(s).
- R Read register or bit(s).
- W Write register or bit(s).
- ** Due to its unique and limited two column functionality, the analog output drivers for the CY8C21x34, CY8C21x23, CY7C603xx, and CYWUSB6953 PSoC devices are described in the Two Column Limited Analog System chapter on page 431.

2. CPU Core (M8C)



This chapter explains the CPU Core, called M8C, and its associated register. It covers the internal M8C registers, address spaces, *instruction* formats, and addressing modes. For additional information concerning the M8C instruction set, refer to the *PSoC Designer Assembly Language User Guide* available at the Cypress website (<http://www.cypress.com/psoc>). For a complete table of the CPU Core registers, refer to the “Summary Table of the Core Registers” on page 60. For a quick reference of all PSoC registers in address order, refer to the *Register Details* chapter on page 147.

2.1 Overview

The **M8C** is a four MIPS 8-bit Harvard architecture microprocessor. Selectable processor clock speeds from 93.7 kHz to 24 MHz allow the M8C to be tuned to a particular application’s performance and power requirements. The M8C supports a rich instruction set which allows for efficient low level language support.

2.2 Internal Registers

The M8C has five internal registers that are used in program execution. The following is a list of these registers.

- Accumulator (A)
- Index (X)
- Program Counter (PC)
- Stack Pointer (SP)
- Flags (F)

All of the internal M8C registers are eight bits in width, except for the PC which is 16 bits wide. Upon **reset**, A, X, PC, and SP are reset to 00h. The Flag register (F) is reset to 02h, indicating that the **Z flag** is **set**.

With each **stack** operation, the SP is automatically incremented or decremented so that it always points to the next stack **byte** in RAM. If the last byte in the stack is at address FFh, the **stack pointer** will wrap to RAM address 00h. It is the **firmware** developer’s responsibility to ensure that the stack does not overlap with user-defined variables in RAM.

With the exception of the F register, the M8C internal registers are not accessible via an explicit register address. The internal M8C registers are accessed using the following instructions:

- MOV A, expr
- MOV X, expr
- SWAP A, SP
- OR F, expr
- JMP LABEL

The F register can be read by using address F7h in either register bank.

2.3 Address Spaces

The M8C has three address spaces: **ROM**, **RAM**, and registers. The ROM address space includes the supervisory ROM (SROM) and the Flash. The ROM address space is accessed via its own address and **data bus**.

The ROM address space is composed of the Supervisory ROM and the on-chip Flash program store. Flash is organized into 64-byte blocks. The user need not be concerned with program store page boundaries, as the M8C automatically increments the 16-bit PC on every instruction making the block boundaries invisible to user code. Instructions occurring on a 256-byte Flash page boundary (with the exception of jmp instructions) incur an extra M8C clock cycle, as the upper byte of the PC is incremented.

The register address space is used to configure the PSoC microcontroller’s programmable blocks. It consists of two banks of 256 bytes each. To switch between banks, the XIO bit in the Flag register is set or cleared (set for Bank1, cleared for Bank0). The common convention is to leave the bank set to Bank0 (XIO cleared), switch to Bank1 as needed (set XIO), then switch back to Bank0.

2.4 Instruction Set Summary

The instruction set is summarized in both [Table 2-1](#) and [Table 2-2](#) (in numeric and *mnemonic* order, respectively), and serves as a quick reference. If more information is needed, the Instruction Set Summary tables are described in detail in the *PSoC Designer Assembly Language User Guide* (refer to the <http://www.cypress.com/psoc> website).

Table 2-1. Instruction Set Summary Sorted Numerically by Opcode

Opcode Hex	Cycles	Bytes	Instruction Format	Flags	Opcode Hex	Cycles	Bytes	Instruction Format	Flags	Opcode Hex	Cycles	Bytes	Instruction Format	Flags
00	15	1	SSC		2D	8	2	OR [X+expr], A	Z	5A	5	2	MOV [expr], X	
01	4	2	ADD A, expr	C, Z	2E	9	3	OR [expr], expr	Z	5B	4	1	MOV A, X	Z
02	6	2	ADD A, [expr]	C, Z	2F	10	3	OR [X+expr], expr	Z	5C	4	1	MOV X, A	
03	7	2	ADD A, [X+expr]	C, Z	30	9	1	HALT		5D	6	2	MOV A, reg[expr]	Z
04	7	2	ADD [expr], A	C, Z	31	4	2	XOR A, expr	Z	5E	7	2	MOV A, reg[X+expr]	Z
05	8	2	ADD [X+expr], A	C, Z	32	6	2	XOR A, [expr]	Z	5F	10	3	MOV [expr], [expr]	
06	9	3	ADD [expr], expr	C, Z	33	7	2	XOR A, [X+expr]	Z	60	5	2	MOV reg[expr], A	
07	10	3	ADD [X+expr], expr	C, Z	34	7	2	XOR [expr], A	Z	61	6	2	MOV reg[X+expr], A	
08	4	1	PUSH A		35	8	2	XOR [X+expr], A	Z	62	8	3	MOV reg[expr], expr	
09	4	2	ADC A, expr	C, Z	36	9	3	XOR [expr], expr	Z	63	9	3	MOV reg[X+expr], expr	
0A	6	2	ADC A, [expr]	C, Z	37	10	3	XOR [X+expr], expr	Z	64	4	1	ASL A	C, Z
0B	7	2	ADC A, [X+expr]	C, Z	38	5	2	ADD SP, expr		65	7	2	ASL [expr]	C, Z
0C	7	2	ADC [expr], A	C, Z	39	5	2	CMP A, expr		66	8	2	ASL [X+expr]	C, Z
0D	8	2	ADC [X+expr], A	C, Z	3A	7	2	CMP A, [expr]	if (A=B) Z=1	67	4	1	ASR A	C, Z
0E	9	3	ADC [expr], expr	C, Z	3B	8	2	CMP A, [X+expr]		68	7	2	ASR [expr]	C, Z
0F	10	3	ADC [X+expr], expr	C, Z	3C	8	3	CMP [expr], expr	if (A<B) C=1	69	8	2	ASR [X+expr]	C, Z
10	4	1	PUSH X		3D	9	3	CMP [X+expr], expr		6A	4	1	RLC A	C, Z
11	4	2	SUB A, expr	C, Z	3E	10	2	MVI A, [[expr]++]	Z	6B	7	2	RLC [expr]	C, Z
12	6	2	SUB A, [expr]	C, Z	3F	10	2	MVI [[expr]++], A		6C	8	2	RLC [X+expr]	C, Z
13	7	2	SUB A, [X+expr]	C, Z	40	4	1	NOP		6D	4	1	RRC A	C, Z
14	7	2	SUB [expr], A	C, Z	41	9	3	AND reg[expr], expr	Z	6E	7	2	RRC [expr]	C, Z
15	8	2	SUB [X+expr], A	C, Z	42	10	3	AND reg[X+expr], expr	Z	6F	8	2	RRC [X+expr]	C, Z
16	9	3	SUB [expr], expr	C, Z	43	9	3	OR reg[expr], expr	Z	70	4	2	AND F, expr	C, Z
17	10	3	SUB [X+expr], expr	C, Z	44	10	3	OR reg[X+expr], expr	Z	71	4	2	OR F, expr	C, Z
18	5	1	POP A	Z	45	9	3	XOR reg[expr], expr	Z	72	4	2	XOR F, expr	C, Z
19	4	2	SBB A, expr	C, Z	46	10	3	XOR reg[X+expr], expr	Z	73	4	1	CPL A	Z
1A	6	2	SBB A, [expr]	C, Z	47	8	3	TST [expr], expr	Z	74	4	1	INC A	C, Z
1B	7	2	SBB A, [X+expr]	C, Z	48	9	3	TST [X+expr], expr	Z	75	4	1	INC X	C, Z
1C	7	2	SBB [expr], A	C, Z	49	9	3	TST reg[expr], expr	Z	76	7	2	INC [expr]	C, Z
1D	8	2	SBB [X+expr], A	C, Z	4A	10	3	TST reg[X+expr], expr	Z	77	8	2	INC [X+expr]	C, Z
1E	9	3	SBB [expr], expr	C, Z	4B	5	1	SWAP A, X	Z	78	4	1	DEC A	C, Z
1F	10	3	SBB [X+expr], expr	C, Z	4C	7	2	SWAP A, [expr]	Z	79	4	1	DEC X	C, Z
20	5	1	POP X		4D	7	2	SWAP X, [expr]		7A	7	2	DEC [expr]	C, Z
21	4	2	AND A, expr	Z	4E	5	1	SWAP A, SP	Z	7B	8	2	DEC [X+expr]	C, Z
22	6	2	AND A, [expr]	Z	4F	4	1	MOV X, SP		7C	13	3	LCALL	
23	7	2	AND A, [X+expr]	Z	50	4	2	MOV A, expr	Z	7D	7	3	LJMP	
24	7	2	AND [expr], A	Z	51	5	2	MOV A, [expr]	Z	7E	10	1	RETI	C, Z
25	8	2	AND [X+expr], A	Z	52	6	2	MOV A, [X+expr]	Z	7F	8	1	RET	
26	9	3	AND [expr], expr	Z	53	5	2	MOV [expr], A		8x	5	2	JMP	
27	10	3	AND [X+expr], expr	Z	54	6	2	MOV [X+expr], A		9x	11	2	CALL	
28	11	1	ROMX	Z	55	8	3	MOV [expr], expr		Ax	5	2	JZ	
29	4	2	OR A, expr	Z	56	9	3	MOV [X+expr], expr		Bx	5	2	JNZ	
2A	6	2	OR A, [expr]	Z	57	4	2	MOV X, expr		Cx	5	2	JC	
2B	7	2	OR A, [X+expr]	Z	58	6	2	MOV X, [expr]		Dx	5	2	JNC	
2C	7	2	OR [expr], A	Z	59	7	2	MOV X, [X+expr]		Ex	7	2	JACC	
										Fx	13	2	INDEX	Z

Note 1 Interrupt acknowledge to Interrupt Vector table = 13 cycles.

Note 2 The number of cycles required by an instruction is increased by one for instructions that span 256 byte page boundaries in the Flash memory space.

Table 2-2. Instruction Set Summary Sorted Alphabetically by Mnemonic

Opcode Hex	Cycles	Bytes	Instruction Format	Flags	Opcode Hex	Cycles	Bytes	Instruction Format	Flags	Opcode Hex	Cycles	Bytes	Instruction Format	Flags
09	4	2	ADC A, expr	C, Z	76	7	2	INC [expr]	C, Z	20	5	1	POP X	
0A	6	2	ADC A, [expr]	C, Z	77	8	2	INC [X+expr]	C, Z	18	5	1	POP A	Z
0B	7	2	ADC A, [X+expr]	C, Z	Fx	13	2	INDEX	Z	10	4	1	PUSH X	
0C	7	2	ADC [expr], A	C, Z	Ex	7	2	JACC		08	4	1	PUSH A	
0D	8	2	ADC [X+expr], A	C, Z	Cx	5	2	JC		7E	10	1	RETI	C, Z
0E	9	3	ADC [expr], expr	C, Z	8x	5	2	JMP		7F	8	1	RET	
0F	10	3	ADC [X+expr], expr	C, Z	Dx	5	2	JNC		6A	4	1	RLC A	C, Z
01	4	2	ADD A, expr	C, Z	Bx	5	2	JNZ		6B	7	2	RLC [expr]	C, Z
02	6	2	ADD A, [expr]	C, Z	Ax	5	2	JZ		6C	8	2	RLC [X+expr]	C, Z
03	7	2	ADD A, [X+expr]	C, Z	7C	13	3	LCALL		28	11	1	ROMX	Z
04	7	2	ADD [expr], A	C, Z	7D	7	3	LJMP		6D	4	1	RRC A	C, Z
05	8	2	ADD [X+expr], A	C, Z	4F	4	1	MOV X, SP		6E	7	2	RRC [expr]	C, Z
06	9	3	ADD [expr], expr	C, Z	50	4	2	MOV A, expr	Z	6F	8	2	RRC [X+expr]	C, Z
07	10	3	ADD [X+expr], expr	C, Z	51	5	2	MOV A, [expr]	Z	19	4	2	SBB A, expr	C, Z
38	5	2	ADD SP, expr		52	6	2	MOV A, [X+expr]	Z	1A	6	2	SBB A, [expr]	C, Z
21	4	2	AND A, expr	Z	53	5	2	MOV [expr], A		1B	7	2	SBB A, [X+expr]	C, Z
22	6	2	AND A, [expr]	Z	54	6	2	MOV [X+expr], A		1C	7	2	SBB [expr], A	C, Z
23	7	2	AND A, [X+expr]	Z	55	8	3	MOV [expr], expr		1D	8	2	SBB [X+expr], A	C, Z
24	7	2	AND [expr], A	Z	56	9	3	MOV [X+expr], expr		1E	9	3	SBB [expr], expr	C, Z
25	8	2	AND [X+expr], A	Z	57	4	2	MOV X, expr		1F	10	3	SBB [X+expr], expr	C, Z
26	9	3	AND [expr], expr	Z	58	6	2	MOV X, [expr]		00	15	1	SSC	
27	10	3	AND [X+expr], expr	Z	59	7	2	MOV X, [X+expr]		11	4	2	SUB A, expr	C, Z
70	4	2	AND F, expr	C, Z	5A	5	2	MOV [expr], X		12	6	2	SUB A, [expr]	C, Z
41	9	3	AND reg[expr], expr	Z	5B	4	1	MOV A, X	Z	13	7	2	SUB A, [X+expr]	C, Z
42	10	3	AND reg[X+expr], expr	Z	5C	4	1	MOV X, A		14	7	2	SUB [expr], A	C, Z
64	4	1	ASL A	C, Z	5D	6	2	MOV A, reg[expr]	Z	15	8	2	SUB [X+expr], A	C, Z
65	7	2	ASL [expr]	C, Z	5E	7	2	MOV A, reg[X+expr]	Z	16	9	3	SUB [expr], expr	C, Z
66	8	2	ASL [X+expr]	C, Z	5F	10	3	MOV [expr], [expr]		17	10	3	SUB [X+expr], expr	C, Z
67	4	1	ASR A	C, Z	60	5	2	MOV reg[expr], A		4B	5	1	SWAP A, X	Z
68	7	2	ASR [expr]	C, Z	61	6	2	MOV reg[X+expr], A		4C	7	2	SWAP A, [expr]	Z
69	8	2	ASR [X+expr]	C, Z	62	8	3	MOV reg[expr], expr		4D	7	2	SWAP X, [expr]	
9x	11	2	CALL		63	9	3	MOV reg[X+expr], expr		4E	5	1	SWAP A, SP	Z
39	5	2	CMP A, expr		3E	10	2	MVI A, [[expr]++]	Z	47	8	3	TST [expr], expr	Z
3A	7	2	CMP A, [expr]		3F	10	2	MVI [[expr]++], A		48	9	3	TST [X+expr], expr	Z
3B	8	2	CMP A, [X+expr]		40	4	1	NOP		49	9	3	TST reg[expr], expr	Z
3C	8	3	CMP [expr], expr		29	4	2	OR A, expr	Z	4A	10	3	TST reg[X+expr], expr	Z
3D	9	3	CMP [X+expr], expr		2A	6	2	OR A, [expr]	Z	72	4	2	XOR F, expr	C, Z
73	4	1	CPL A	Z	2B	7	2	OR A, [X+expr]	Z	31	4	2	XOR A, expr	Z
78	4	1	DEC A	C, Z	2C	7	2	OR [expr], A	Z	32	6	2	XOR A, [expr]	Z
79	4	1	DEC X	C, Z	2D	8	2	OR [X+expr], A	Z	33	7	2	XOR A, [X+expr]	Z
7A	7	2	DEC [expr]	C, Z	2E	9	3	OR [expr], expr	Z	34	7	2	XOR [expr], A	Z
7B	8	2	DEC [X+expr]	C, Z	2F	10	3	OR [X+expr], expr	Z	35	8	2	XOR [X+expr], A	Z
30	9	1	HALT		43	9	3	OR reg[expr], expr	Z	36	9	3	XOR [expr], expr	Z
74	4	1	INC A	C, Z	44	10	3	OR reg[X+expr], expr	Z	37	10	3	XOR [X+expr], expr	Z
75	4	1	INC X	C, Z	71	4	2	OR F, expr	C, Z	45	9	3	XOR reg[expr], expr	Z
										46	10	3	XOR reg[X+expr], expr	Z

Note 1 Interrupt acknowledge to Interrupt Vector table = 13 cycles.

Note 2 The number of cycles required by an instruction is increased by one for instructions that span 256 byte page boundaries in the Flash memory space.

2.5 Instruction Formats

The M8C has a total of seven instruction formats which use instruction lengths of one, two, and three bytes. All instruction bytes are fetched from the program memory (Flash), using an address and data bus that are independent from the address and data buses used for register and RAM access.

While examples of instructions are given in this section, refer to the *PSoC Designer Assembly Language User Guide* for detailed information on individual instructions.

2.5.1 One-Byte Instructions

Many instructions, such as some of the MOV instructions, have single-byte forms, because they do not use an address or data as an operand. As shown in [Table 2-3](#), one-byte instructions use an 8-bit opcode. The set of one-byte instructions can be divided into four categories, according to where their results are stored.

Table 2-3. One-Byte Instruction Format

Byte 0
8-Bit Opcode

The first category of one-byte instructions are those that do not update any registers or RAM. Only the one-byte NOP and SSC instructions fit this category. While the **program counter** is incremented as these instructions execute, they do not cause any other internal M8C registers to be updated, nor do these instructions directly affect the register space or the RAM address space. The SSC instruction will cause SROM code to run, which will modify RAM and the M8C internal registers.

The second category has only the two PUSH instructions in it. The PUSH instructions are unique, because they are the only one-byte instructions that cause a RAM address to be modified. These instructions automatically increment the SP.

The third category has only the HALT instruction in it. The HALT instruction is unique, because it is the only a one-byte instruction that causes a user register to be modified. The HALT instruction modifies user register space address FFh (CPU_SCR register).

The final category for one-byte instructions are those that cause updates of the internal M8C registers. This category holds the largest number of instructions: ASL, ASR, CPL, DEC, INC, MOV, POP, RET, RETI, RLC, ROMX, RRC, SWAP. These instructions can cause the A, X, and SP registers or SRAM to update.

2.5.2 Two-Byte Instructions

The majority of M8C instructions are two bytes in length. While these instructions can be divided into categories identical to the one-byte instructions, this would not provide a useful distinction between the three two-byte instruction formats that the M8C uses.

Table 2-4. Two-Byte Instruction Formats

Byte 0	Byte 1
4-Bit Opcode	12-Bit Relative Address
8-Bit Opcode	8-Bit Data
8-Bit Opcode	8-Bit Address

The first two-byte instruction format, shown in the first row of [Table 2-4](#), is used by short jumps and calls: CALL, JMP, JACC, INDEX, JC, JNC, JNZ, JZ. This instruction format uses only four bits for the instruction opcode, leaving 12 bits to store the relative destination address in a two's-complement form. These instructions can change program execution to an address relative to the current address by -2048 or +2047.

The second two-byte instruction format, shown in the second row of [Table 2-4](#), is used by instructions that employ the Source Immediate addressing **mode** (see "[Source Immediate](#)" on page 67). The destination for these instructions is an internal M8C register, while the source is a constant value. An example of this type of instruction would be ADD A, 7.

The third two-byte instruction format, shown in the third row of [Table 2-4](#), is used by a wide range of instructions and addressing modes. The following is a list of the addressing modes that use this third two-byte instruction format:

- Source Direct (ADD A, [7])
- Source Indexed (ADD A, [X+7])
- Destination Direct (ADD [7], A)
- Destination Indexed (ADD [X+7], A)
- Source Indirect Post Increment (MVI A, [7])
- Destination Indirect Post Increment (MVI [7], A)

For more information on addressing modes see "[Addressing Modes](#)" on page 67.

2.5.3 Three-Byte Instructions

The three-byte instruction formats are the second most prevalent instruction formats. These instructions need three bytes because they either move data between two addresses in the user-accessible address space (registers and RAM) or they hold 16-bit absolute addresses as the destination of a long jump or long call.

Table 2-5. Three-Byte Instruction Formats

Byte 0	Byte 1	Byte 2
8-Bit Opcode	16-Bit Address (MSB, LSB)	
8-Bit Opcode	8-Bit Address	8-Bit Data
8-Bit Opcode	8-Bit Address	8-Bit Address

The first instruction format, shown in the first row of Table 2-5, is used by the LJMP and LCALL instructions. These instructions change program execution unconditionally to an absolute address. The instructions use an 8-bit opcode, leaving room for a 16-bit destination address.

The second three-byte instruction format, shown in the second row of Table 2-5, is used by the following two addressing modes:

- Destination Direct Source Immediate (ADD [7], 5)
- Destination Indexed Source Immediate (ADD [X+7], 5)

The third three-byte instruction format, shown in the third row of Table 2-5, is for the Destination Direct Source Direct addressing mode, which is used by only one instruction. This instruction format uses an 8-bit opcode followed by two 8-bit addresses. The first address is the destination address in RAM, while the second address is the source address in RAM. The following is an example of this instruction:

```
MOV [7], [5]
```

2.6 Addressing Modes

The M8C has ten addressing modes. These modes are detailed and located on the following pages:

- “Source Immediate” on page 67.
- “Source Direct” on page 68.
- “Source Indexed” on page 68.
- “Destination Direct” on page 69.
- “Destination Indexed” on page 69.
- “Destination Direct Source Immediate” on page 69.
- “Destination Indexed Source Immediate” on page 70.
- “Destination Direct Source Direct” on page 70.
- “Source Indirect Post Increment” on page 71.
- “Destination Indirect Post Increment” on page 71.

2.6.1 Source Immediate

For these instructions, the source value is stored in operand 1 of the instruction. The result of these instructions is placed in either the M8C A, F, or X register as indicated by the instruction’s opcode. All instructions using the Source Immediate addressing mode are two bytes in length.

Table 2-6. Source Immediate

Opcode	Operand 1
Instruction	Immediate Value

Source Immediate Examples:

Source Code	Machine Code	Comments
ADD A, 7	01 07	The immediate value 7 is added to the Accumulator. The result is placed in the Accumulator.
MOV X, 8	57 08	The immediate value 8 is moved into the X register.
AND F, 9	70 09	The immediate value of 9 is logically AND’ed with the F register and the result is placed in the F register.

2.6.2 Source Direct

For these instructions, the source address is stored in operand 1 of the instruction. During instruction execution, the address will be used to retrieve the source value from RAM or register address space. The result of these instructions is placed in either the M8C A or X register as indicated by the instruction's opcode. All instructions using the Source Direct addressing mode are two bytes in length.

Table 2-7. Source Direct

Opcode	Operand 1
Instruction	Source Address

Source Direct Examples:

Source Code	Machine Code	Comments
ADD A, [7]	02 07	The value in memory at address 7 is added to the Accumulator and the result is placed into the Accumulator.
MOV A, REG[8]	5D 08	The value in the register space at address 8 is moved into the Accumulator.

2.6.3 Source Indexed

For these instructions, the source offset from the X register is stored in operand 1 of the instruction. During instruction execution, the current X register value is added to the signed offset, to determine the address of the source value in RAM or register address space. The result of these instructions is placed in either the M8C A or X register as indicated by the instruction's opcode. All instructions using the Source Indexed addressing mode are two bytes in length.

Table 2-8. Source Indexed

Opcode	Operand 1
Instruction	Source Index

Source Indexed Examples:

Source Code	Machine Code	Comments
ADD A, [X+7]	03 07	The value in memory at address X+7 is added to the Accumulator. The result is placed in the Accumulator.
MOV X, [X+8]	59 08	The value in RAM at address X+8 is moved into the X register.

2.6.4 Destination Direct

For these instructions, the destination address is stored in the machine code of the instruction. The source for the operation is either the M8C A or X register as indicated by the instruction's opcode. All instructions using the Destination Direct addressing mode are two bytes in length.

Table 2-9. Destination Direct

Opcode	Operand 1
Instruction	Destination Address

Destination Direct Examples:

Source Code	Machine Code	Comments
ADD [7], A	04 07	The value in the Accumulator is added to memory at address 7. The result is placed in memory at address 7. The Accumulator is unchanged.
MOV REG[8], A	60 08	The Accumulator value is moved to register space at address 8. The Accumulator is unchanged.

2.6.5 Destination Indexed

For these instructions, the destination offset from the X register is stored in the machine code for the instruction. The source for the operation is either the M8C A register or an immediate value as indicated by the instruction's opcode. All instructions using the Destination Indexed addressing mode are two bytes in length.

Table 2-10. Destination Indexed

Opcode	Operand 1
Instruction	Destination Index

Destination Indexed Example:

Source Code	Machine Code	Comments
ADD [X+7], A	05 07	The value in memory at address X+7 is added to the Accumulator. The result is placed in memory at address X+7. The Accumulator is unchanged.

2.6.6 Destination Direct Source Immediate

For these instructions, the destination address is stored in operand 1 of the instruction. The source value is stored in operand 2 of the instruction. All instructions using the Destination Direct Source Immediate addressing mode are three bytes in length.

Table 2-11. Destination Direct Source Immediate

Opcode	Operand 1	Operand 2
Instruction	Destination Address	Immediate Value

Destination Direct Source Immediate Examples:

Source Code	Machine Code	Comments
ADD [7], 5	06 07 05	The value in memory at address 7 is added to the immediate value 5. The result is placed in memory at address 7.
MOV REG[8], 6	62 08 06	The immediate value 6 is moved into register space at address 8.

2.6.7 Destination Indexed Source Immediate

For these instructions, the destination offset from the X register is stored in operand 1 of the instruction. The source value is stored in operand 2 of the instruction. All instructions using the Destination Indexed Source Immediate addressing mode are three bytes in length.

Table 2-12. Destination Indexed Source Immediate

Opcode	Operand 1	Operand 2
Instruction	Destination Index	Immediate Value

Destination Indexed Source Immediate Examples:

Source Code	Machine Code	Comments
ADD [X+7], 5	07 07 05	The value in memory at address X+7 is added to the immediate value 5. The result is placed in memory at address X+7.
MOV REG[X+8], 6	63 08 06	The immediate value 6 is moved into the register space at address X+8.

2.6.8 Destination Direct Source Direct

Only one instruction uses this addressing mode. The destination address is stored in operand 1 of the instruction. The source address is stored in operand 2 of the instruction. The instruction using the Destination Direct Source Direct addressing mode is three bytes in length.

Table 2-13. Destination Direct Source Direct

Opcode	Operand 1	Operand 2
Instruction	Destination Address	Source Address

Destination Direct Source Direct Example:

Source Code	Machine Code	Comments
MOV [7], [8]	5F 07 08	The value in memory at address 8 is moved to memory at address 7.

2.6.9 Source Indirect Post Increment

Only one instruction uses this addressing mode. The source address stored in operand 1 is actually the address of a pointer. During instruction execution, the pointer's current value is read to determine the address in RAM where the source value is found. The pointer's value is incremented after the source value is read. For PSoC microcontrollers with more than 256 bytes of RAM, the Data Page Read (MVR_PP) register is used to determine which RAM page to use with the source address. Therefore, values from pages other than the current page can be retrieved without changing the Current Page Pointer (CUR_PP). The pointer is always read from the current RAM page. For information on the MVR_PP and CUR_PP registers, see the [Register Details chapter on page 147](#). The instruction using the Source Indirect Post Increment addressing mode is two bytes in length.

Table 2-14. Source Indirect Post Increment

Opcode	Operand 1
Instruction	Source Address Pointer

Source Indirect Post Increment Example:

Source Code	Machine Code	Comments
MVI A, [8]	3E 08	The value in memory at address 8 (the indirect address) points to a memory location in RAM. The value at the memory location, pointed to by the indirect address, is moved into the Accumulator. The indirect address, at address 8 in memory, is then incremented.

2.6.10 Destination Indirect Post Increment

Only one instruction uses this addressing mode. The destination address stored in operand 1 is actually the address of a pointer. During instruction execution, the pointer's current value is read to determine the destination address in RAM where the Accumulator's value is stored. The pointer's value is incremented, after the value is written to the destination address. For PSoC microcontrollers with more than 256 bytes of RAM, the Data Page Write (MVW_PP) register is used to determine which RAM page to use with the destination address. Therefore, values can be stored in pages other than the current page without changing the Current Page Pointer (CUR_PP). The pointer is always read from the current RAM page. For information on the MVR_PP and CUR_PP registers, see the [Register Details chapter on page 147](#). The instruction using the Destination Indirect Post Increment addressing mode is two bytes in length.

Table 2-15. Destination Indirect Post Increment

Opcode	Operand 1
Instruction	Destination Address Pointer

Destination Indirect Post Increment Example:

Source Code	Machine Code	Comments
MVI [8], A	3F 08	The value in memory at address 8 (the indirect address) points to a memory location in RAM. The Accumulator value is moved into the memory location pointed to by the indirect address. The indirect address, at address 8 in memory, is then incremented.

2.7 Register Definitions

The following register is associated with the CPU Core (M8C). The register description has an associated register table showing the bit structure. The bits that are grayed out in the table are reserved bits and are not detailed in the register description that follows. Reserved bits should always be written with a value of '0'.

2.7.1 CPU_F Register

Address	Name	Bit 7	Bit 6	Bit 5	Bit 4	Bit 3	Bit 2	Bit 1	Bit 0	Access
x,F7h	CPU_F	PgMode[1:0]			XIO		Carry	Zero	GIE	RL : 02

LEGEND

L The AND F, expr; OR F, expr; and XOR F, expr flag instructions can be used to modify this register.

x An "x" before the comma in the address field indicates that this register can be read or written to no matter what bank is used.

The M8C Flag Register (CPU_F) provides read access to the M8C flags.

Bits 7 and 6: PgMode[1:0]. PgMode determines how the CUR_PP, STK_PP, and IDX_PP registers are used in forming effective RAM addresses for Direct Address mode and Indexed Address mode operands. PgMode also determines whether the stack page is determined by the STK_PP or IDX_PP register.

Bit 4: XIO. The IO Bank Select bit, also known as the register bank select bit, is used to select the register bank that is active for a register read or write. This bit allows the PSoC device to have 512 8-bit registers and therefore, can be thought of as the ninth address bit for registers. The address space accessed when the XIO bit is set to '0' is called the **user space**, while the address space accessed when the XIO bit is set to '1' is called the **configuration space**.

Bit 2: Carry. The Carry flag bit is set or cleared in response to the result of several instructions. It can also be manipulated by the flag-logic opcodes (for example, OR F, 4). See the *PSoC Designer Assembly Guide User Manual* for more details.

Bit 1: Zero. The Zero flag bit is set or cleared in response to the result of several instructions. It can also be manipulated by the flag-logic opcodes (for example, OR F, 2). See the *PSoC Designer Assembly Guide User Manual* for more details.

Bit 0: GIE. The state of the Global Interrupt Enable bit determines whether interrupts (by way of the interrupt request (IRQ)) will be recognized by the M8C. This bit is set or cleared by the user, using the flag-logic instructions (for example, OR F, 1). GIE is also cleared automatically when an interrupt is processed, after the flag byte has been stored on the stack, preventing nested interrupts. If desired, the bit can be set in an **interrupt service routine (ISR)**.

For GIE=1, the M8C samples the IRQ input for each instruction. For GIE=0, the M8C ignores the IRQ.

For additional information, refer to the [CPU_F register](#) on page 249.

3. Supervisory ROM (SROM)



This chapter discusses the Supervisory ROM (SROM) functions and its associated registers. For a complete table of the SROM registers, refer to the “Summary Table of the Core Registers” on page 60. For a quick reference of all PSoC registers in address order, refer to the Register Details chapter on page 147.

3.1 Architectural Description

The SROM holds code that is used to boot the PSoC device, calibrate circuitry, and perform Flash operations. The functions provided by the SROM are called from code stored in the Flash or by device programmers.

The SROM is used to boot the part and provide **interface** functions to the Flash banks. (Table 3-1 lists the SROM functions.) The SROM functions are accessed by executing the Supervisory System Call instruction (SSC) which has an opcode of 00h. Prior to executing the SSC, the M8C’s **accumulator** needs to load with the desired SROM function code from Table 3-1. Attempting to access undefined functions will cause a HALT. The SROM functions execute code with calls; therefore, the functions require stack space. With the exception of Reset, all of the SROM functions have a **parameter block** in SRAM that must be configured before executing the SSC. Table 3-2 lists all possible parameter block variables. The meaning of each **parameter**, with regards to a specific SROM function, is described later in this chapter. Because the SSC instruction clears the CPU_F PgMode bits, all parameter block variable addresses are in SRAM Page 0. The CPU_F value is automatically restored at the end of the SROM function.

Note For PSoC devices with more than 256 bytes of SRAM (that is, more than 1 page of SRAM, see the table titled “PSoC Device SRAM Availability” on page 85), the MVR_PP and the MVW_PP pointers are not disabled by clearing the CPU_F PgMode bits. Therefore, the POINTER parameter is interpreted as an address in the page indicated by the MVI page pointers, when the supervisory operation is called. This allows the data **buffer** used in the supervisory operation to be located in any SRAM page. (See the RAM Paging chapter on page 85 for more details regarding the MVR_PP and MVW_PP pointers.)

Table 3-1. List of SROM Functions

Function Code	Function Name	Stack Space Needed	Page
00h	SWBootReset	0	74
01h	ReadBlock	7	75
02h	WriteBlock	10	75
03h	EraseBlock	9	76
06h	TableRead	3	77
07h	Checksum	3	77
08h	Calibrate0	4	77
09h	Calibrate1	3	78

Note ProtectBlock (described on page 76) and EraseAll (described on page 77) SROM functions are not listed in the table above because they are dependent on external programming.

Two important variables that are used for all functions are KEY1 and KEY2. These variables are used to help discriminate between valid SSCs and inadvertent SSCs. KEY1 must always have a value of 3Ah, while KEY2 must have the same value as the stack pointer when the SROM function begins execution. This would be the SP (Stack Pointer) value when the SSC opcode is executed, plus three. For all SROM functions except SWBootReset, if either of the keys do not match the expected values, the M8C will halt. The SWBootReset function does not check the key values. It only checks to see if the accumulator’s value is 0x00. The following code example puts the correct value in KEY1 and KEY2. The code is preceded by a HALT, to force the program to jump directly into the setup code and not accidentally run into it.

Supervisory ROM (SROM)

```

1.      halt
2. SSCOP: mov [KEY1], 3ah
3.      mov X, SP
4.      mov A, X
5.      add A, 3
6.      mov [KEY2], A

```

Table 3-2. SROM Function Variables

Variable Name	SRAM Address
KEY1 / RETURN CODE	0,F8h
KEY2	0,F9h
BLOCKID	0,FAh
POINTER	0,FBh
CLOCK	0,FC h
Reserved	0,FDh
DELAY	0,FEh
Reserved	0,FFh

3.1.1 Additional SROM Feature

The SROM has the following additional feature.

Return Codes: These aid in the determination of success or failure of a particular function. The return code is stored in KEY1's position in the parameter block. The CheckSum and TableRead functions do not have return codes because KEY1's position in the parameter block is used to return other data.

Table 3-3. SROM Return Code Meanings

Return Code Value	Description
00h	Success
01h	Function not allowed due to level of protection on the block.
02h	Software reset without hardware reset.
03h	Fatal error, SROM halted.

Note Read, write, and erase operations may fail if the target block is read or write protected. Block protection levels are set during device programming and can not be modified from code in the PSoC device.

3.1.2 SROM Function Descriptions

3.1.2.1 SWBootReset Function

The SROM function SWBootReset is responsible for transitioning the device from a reset state to running **user** code. See "System Resets" on page 501 for more information on what events will cause the SWBootReset function to execute.

The SWBootReset function is executed whenever the SROM is entered with an M8C accumulator value of 00h; the SRAM parameter block is not used as an input to the function. This will happen, by design, after a **hardware** reset, because the M8C's accumulator is reset to 00h or

when user code executes the SSC instruction with an accumulator value of 00h.

If the **checksum** of the calibration data is valid, the SWBootReset function ends by setting the internal M8C registers (CPU_SP, CPU_PC, CPU_X, CPU_F, CPU_A) to 00h writing 00h to most SRAM addresses in SRAM Page 0 and then begins to execute user code at address 0000h. (See Table 3-4 and the following paragraphs for more information on which SRAM addresses are modified.) If the checksum is not valid, an internal reset is executed and the boot process starts over. If this condition occurs, the internal reset status bit (IRESS) is set in the CPU_SCR1 register.

In PSoC devices with more than 256 bytes of SRAM, no SRAM is modified by the SWBootReset function in SRAM pages numbered higher than '0'.

Table 3-4 documents the value of all the SRAM addresses in Page 0 after a successful SWBootReset. A cell in the table with "xx" indicates that the SRAM address is not modified by the SWBootReset function. A hex value in a cell indicates that the address should always have the indicated value after a successful SWBootReset. A cell with a "??" in it indicates that the value, after a SWBootReset, is determined by the value of IRAMDIS bit in the CPU_SCR1 register. If IRAMDIS is not set, these addresses will be initialized to 00h. If IRAMDIS is set, these addresses will not be modified by a SWBootReset after a watchdog reset. The IRAMDIS bit allows variables to be preserved even if a watchdog reset (WDR) occurs. The IRAMDIS bit is reset by all system resets except watchdog reset. Therefore, this bit is only useful for watchdog resets and not general resets.

Table 3-4. SRAM Map Post SWBootReset (00h)

Address	0	1	2	3	4	5	6	7
	8	9	A	B	C	D	E	F
0x0_	0x00	0x00	0x00	??	??	??	??	??
	??	??	??	??	??	??	??	??
0x1_	??	??	??	??	??	??	??	??
	??	??	??	??	??	??	??	??
0x2_	??	??	??	??	??	??	??	??
	??	??	??	??	??	??	??	??
0x3_	??	??	??	??	??	??	??	??
	??	??	??	??	??	??	??	??
0x4_	??	??	??	??	??	??	??	??
	??	??	??	??	??	??	??	??
0x5_	??	??	??	??	??	??	??	??
	??	??	??	??	??	??	??	??
0x6_	??	??	??	??	??	??	??	??
	??	??	??	??	??	??	??	??
0x7_	??	??	??	??	??	??	??	??
	??	??	??	??	??	??	??	??
0x8_	??	??	??	??	??	??	??	??
	??	??	??	??	??	??	??	??
0x9_	??	??	??	??	??	??	??	??
	??	??	??	??	??	??	??	??
0xA_	??	??	??	??	??	??	??	??
	??	??	??	??	??	??	??	??
0xB_	??	??	??	??	??	??	??	??
	??	??	??	??	??	??	??	??
0xC_	??	??	??	??	??	??	??	??
	??	??	??	??	??	??	??	??
0xD_	??	??	??	??	??	??	??	??
	0x00	0x00	0x00	0x00	0x00	0x00	0x00	0x00
0xE_	0x00	0x00	0x00	0x00	0x00	0x00	0x00	0x00
	0x00	0x00	0x00	0x00	0x00	0x00	0x00	0x00
0xF_	0x00	0x00	0x00	0x00	0x00	0x00	??	??
	0x00	xx	0x00	0x00	0xn	xx	0x00	0x00

Address F8h is the return code byte for all SROM functions (except Checksum and TableRead); for this function, the only acceptable values are 00h and 02h. Address FCh is the fail count variable. After POR (Power on Reset), WDR, or XRES (External Reset), the variable is initialized to 00h by the SROM. Each time the checksum fails, the fail count is incremented. Therefore, if it takes two passes through SWBootReset to get a good checksum, the fail count would be 01h.

3.1.2.2 ReadBlock Function

The ReadBlock function is used to read 64 contiguous bytes from Flash: a **block**. The number of blocks in a device is the total number of bytes divided by 64. Refer to Table 3-5 to determine the amount of space in your PSoC device.

Table 3-5. Flash Memory Organization

PSoC Device	Amount of Flash	Amount of SRAM	Number of Blocks per Bank	Number of Banks
CY8C29x66	32 KB	2 KB	128	4
CY8CPLC20				
CY8CLE16P01				
CY8CNP1xx				
CY8C27x43	16 KB	256 Bytes	256	1
CY8C24x94	16 KB	1 KB	128	2
CY8C24x23	4 KB	256 Bytes	64	1
CY8C24x23A	4 KB	256 Bytes	64	1
CY8C22x13	2 KB	256 Bytes	32	1
CY8C21x34	8 KB	512 Bytes	128	1
CY8C21x23	4 KB	256 Bytes	64	1
CY7C64215	16 KB	1 KB	128	2
CY7C603xx	8 KB	512 Bytes	128	1
CYWUSB6953	8 KB	512 Bytes	128	1

The first thing the ReadBlock function does is check the protection bits to determine if the desired BLOCKID is readable. If read protection is turned on, the ReadBlock function will exit setting the accumulator and KEY2 back to 00h. KEY1 will have a value of 01h, indicating a read failure.

If read protection is not enabled, the function will read 64 bytes from the Flash using a ROMX instruction and store the results in SRAM using an MVI instruction. The 64 bytes are stored in SRAM, beginning at the address indicated by the value of the POINTER parameter. When the ReadBlock completes successfully, the accumulator, KEY1, and KEY2 will all have a value of 00h.

If the PSoC device has more than one bank of Flash, the bank value in the FLS_PR1 register must be set prior to executing the SSC instruction. Refer to Table 3-5.

Note A MVI [expr], A is used to store the Flash block contents in SRAM; thus, the MVW_PP register can be set to indicate which SRAM pages will receive the data.

Table 3-6. ReadBlock Parameters (01h)

Name	Address	Type	Description
MVW_PP	0,D5h	Register	MVI write page pointer register
KEY1	0,F8h	RAM	3Ah
KEY2	0,F9h	RAM	Stack Pointer value+3, when SSC is executed.
BLOCKID	0,FAh	RAM	Flash block number
POINTER	0,FBh	RAM	Addresses in SRAM where returned data should be stored.
FLS_PR1	1,FAh	Register	Flash bank number.

3.1.2.3 WriteBlock Function

The WriteBlock function is used to store data in the Flash. Data is moved 64 bytes at a time from SRAM to Flash using this function. Before a write can be performed, either an EraseAll or an EraseBlock must be completed successfully.

The first thing the WriteBlock function does is check the protection bits and determine if the desired BLOCKID is writeable. If write protection is turned on, the WriteBlock function will exit, setting the accumulator and KEY2 back to 00h. KEY1 will have a value of 01h, indicating a write failure. Write protection is set when the PSoC device is programmed externally and cannot be changed through the SSC function.

The BLOCKID of the **Flash block**, where the data is stored, must be determined and stored at SRAM address FAh. For valid BLOCKID values, refer to [Table 3-5](#).

An MVI A, [expr] instruction is used to move data from SRAM into Flash. Therefore, the MVI read pointer (MVR_PP register) can be used to specify which SRAM page data is pulled from. Using the MVI read pointer and the parameter blocks POINTER value allows the SRAM WriteBlock function to move data from any SRAM page into any Flash block, in either Flash bank.

The SRAM address, of the first of the 64 bytes to be stored in Flash, must be indicated using the POINTER variable in the parameter block (SRAM address FBh).

Finally, the CLOCK and DELAY value must be set correctly. The CLOCK value determines the length of the write **pulse** that will be used to store the data in the Flash. The CLOCK and DELAY values are dependent on the CPU speed and must be set correctly. Refer to “Clocking” on page 83 for additional information.

If the PSoC device you are using has more than one bank of Flash, set the bank value in the FLS_PR1 register before executing the SSC instruction. See [Table 3-5](#).

Notes

1. Writing to the flash clears the sleep timer. Be careful if you are using the sleep timer for precision time keeping.
2. When writing to flash, make the IMO active.

Table 3-7. WriteBlock Parameters (02h)

Name	Address	Type	Description
MVR_PP	0,D4h	Register	MVI read page pointer register.
KEY1	0,F8h	RAM	3Ah
KEY2	0,F9h	RAM	Stack Pointer value+3, when SSC is executed.
BLOCKID	0,FAh	RAM	Flash block number.
POINTER	0,FBh	RAM	First of 64 addresses in SRAM, where the data to be stored in Flash is located prior to calling WriteBlock.
CLOCK	0,FCh	RAM	Clock divider used to set the write pulse width.
DELAY	0,FEh	RAM	For a CPU speed of 12 MHz set to 56h.
FLS_PR1	1,FAh	Register	Flash bank number.

3.1.2.4 EraseBlock Function

The EraseBlock function is used to erase a block of 64 contiguous bytes in Flash.

The first thing the EraseBlock function does is check the protection bits and determine if the desired BLOCKID is writeable. If write protection is turned on, the EraseBlock function will exit, setting the accumulator and KEY2 back to 00h. KEY1 will have a value of 01h, indicating a write failure.

To set up the parameter block for the EraseBlock function, correct key values must be stored in KEY1 and KEY2. The block number to be erased must be stored in the BLOCKID variable, and the CLOCK and DELAY values must be set based on the current CPU speed. For more information on setting the CLOCK and DELAY values, see “Clocking” on page 83.

If the PSoC device you are using has more than one bank of Flash, the bank value in the FLS_PR1 register must be set prior to executing the SSC instruction. Refer to [Table 3-5](#).

Table 3-8. EraseBlock Parameters (03h)

Name	Address	Type	Description
KEY1	0,F8h	RAM	3Ah
KEY2	0,F9h	RAM	Stack Pointer value+3, when SSC is executed.
BLOCKID	0,FAh	RAM	Flash block number.
CLOCK	0,FCh	RAM	Clock divider used to set the erase pulse width.
DELAY	0,FEh	RAM	For a CPU speed of 12 MHz set to 56h.
FLS_PR1	1,FAh	Register	Flash bank number.

3.1.2.5 ProtectBlock Function

The PSoC devices offer Flash protection on a block-by-block basis. [Table 3-9](#) lists the protection modes available. In the table, ER and EW are used to indicate the ability to perform external reads and writes (that is, by an external programmer). For internal reads, IW is used. Internal reading is always permitted by way of the ROMX instruction. The ability to read by way of the SRAM ReadBlock function is indicated by SR.

In the table below, note that all protection is removed by EraseAll.

Table 3-9. Protect Block Modes

Mode	Settings	Description	In PSoC Designer
00b	SR ER EW IW	Unprotected	U = Unprotected
01b	SR ER EW IW	Read protect	F = Factory upgrade
10b	SR ER EW IW	Disable external write	R = Field upgrade
11b	SR ER EW IW	Disable internal write	W = Full protection

3.1.2.6 TableRead Function

The TableRead function gives the user access to part specific data stored in the Flash during manufacturing. The Flash for these tables is separate from the program Flash and is not directly accessible.

One of the uses of the SROM TableRead function is to retrieve the values needed to optimize Flash programming for temperature. More information about how to use these

values may be found in the section titled “Clocking” on page 83.

Table 3-10. TableRead Parameters (06h)

Name	Address	Type	Description
KEY1	0,F8h	RAM	3Ah
KEY2	0,F9h	RAM	Stack Pointer value+3, when SSC is executed.
BLOCKID	0,FAh	RAM	Table number to read.

3.1.2.7 EraseAll Function

The EraseAll function performs a series of steps that destroys the user data in the Flash banks and resets the protection block in each Flash bank to all zeros (the unprotected state). This function may only be executed by an external programmer. If EraseAll is executed from code, the M8C will HALT without touching the Flash or protections.

Table 3-11. Flash Tables with Assigned Values in Flash Bank 0

	F8h	F9h	FAh	FBh	FCh	FDh	FEh	FFh
Table 0	Silicon ID							
Table 1	Voltage Reference Trim for 3.3V reg[1,EA]	IMO Trim for 3.3V reg[1,E8]	Room Temperature Calibration for 3.3V	Hot Temperature Calibration for 3.3V	Voltage Reference Trim for 5V reg[1,EA]	IMO Trim for 5V reg[1,E8]	Room Temperature Calibration for 5V	Hot Temperature Calibration for 5V
Table 2	Voltage Reference Trim for 2.7V reg[1,EA]	IMO Slow Trim 12 MHz Vdd = 2.7V	Room Temperature Calibration for 2.7V *	Hot Temperature Calibration for 2.7V *	IMO Slow Trim 6 MHz Vdd = 3.3V	IMO Slow Trim 6 MHz Vdd = 2.7V	IMO Slow Trim 6 MHz Vdd = 5.0V	
Table 3	M (cold)	B (cold)	Mult (cold)	M (hot)	B (hot)	Mult (hot)	00h	01h

* CY8C24x94 and CY7C64215 Table 2: FAh = IMO Trim 2 for 3.3V, FBh = IMO Trim 2 for 5V.

3.1.2.8 Checksum Function

The Checksum function calculates a 16-bit checksum over a user specifiable number of blocks, within a single **Flash bank** starting at block zero. The BLOCKID parameter is used to pass in the number of blocks to checksum. A BLOCKID value of ‘1’ will calculate the checksum of only block 0, while a BLOCKID value of ‘0’ will calculate the checksum of 256 blocks in the bank.

The 16-bit checksum is returned in KEY1 and KEY2. The parameter KEY1 holds the lower 8 bits of the checksum and the parameter KEY2 holds the upper 8 bits of the checksum. For devices with multiple Flash banks, the checksum function must be called once for each Flash bank. The SROM Checksum function will operate on the Flash bank indicated by the Bank bit in the FLS_PR1 register.

Table 3-12. Checksum Parameters (07h)

Name	Address	Type	Description
KEY1	0,F8h	RAM	3Ah
KEY2	0,F9h	RAM	Stack Pointer value+3, when SSC is executed.
BLOCKID	0,FAh	RAM	Number of Flash blocks to calculate checksum on.
FLS_PR1	1,FAh	Register	Flash bank number.

3.1.2.9 Calibrate0 Function

The Calibrate0 function transfers the calibration values stored in a special area of the Flash to their appropriate registers. This function may be executed at any time to set all calibration values back to their 5V values. However, it should not be necessary to call this function. This function is simply documented for completeness. 3.3V calibration values are accessed by way of the TableRead function, which

is described in the section titled “TableRead Function” on

page 77.

Table 3-13. Calibrate0 Parameters (08h)

Name	Address	Type	Description
KEY1	0,F8h	RAM	3Ah
KEY2	0,F9h	RAM	Stack Pointer value+3, when SSC is executed.

3.1.2.10 Calibrate1 Function

While the Calibrate1 function is a completely separate function from Calibrate0, they perform the same function, which is to transfer the calibration values stored in a special area of the Flash to their appropriate registers. What is unique about Calibrate1 is that it calculates a checksum of the calibration data and, if that checksum is determined to be invalid, Calibrate1 will cause a **hardware reset** by generating an internal reset. If this occurs, it is indicated by setting the Internal Reset Status bit (IRESS) in the CPU_SCR1 register.

The Calibrate1 function uses SRAM to calculate a checksum of the calibration data. The POINTER value is used to indicate the address of a 30-byte buffer used by this function. When the function completes, the 30 bytes will be set to 00h.

An MVI A, [expr] and an MVI [expr], A instruction are used to move data between SRAM and Flash. Therefore, the MVI write pointer (MVW_PP) and the MVI read pointer (MVR_PP) must be specified to the same SRAM page to control the page of RAM used for the operations.

Calibrate1 was created as a sub-function of SWBootReset and the Calibrate1 function code was added to provide **direct access**. For more information on how Calibrate1 works, see the SWBootReset section.

This function may be executed at any time to set all calibration values back to their 5V values. However, it should not be necessary to call this function. This function is simply documented for completeness. This function has no argument to select between 5V and 3.3V calibration values; therefore, it always defaults to 5V values. 3.3V calibration values are accessed by way of the TableRead function, which is described in the section titled "[TableRead Function](#)" on page 77.

3.2 PSoC Device Distinctions

For the CY8C21x34, CY8C21x23, CY7C603xx, and CYWUSB6953 PSoC devices, a BLOCKID value of '0' will cause all available Flash to be checksummed. In all other

Table 3-14. Calibrate1 Parameters (09h)

Name	Address	Type	Description
KEY1	0,F8h	RAM	3Ah
KEY2	0,F9h	RAM	Stack Pointer value+3, when SSC is executed.
POINTER	0,FBh	RAM	First of 30 SRAM addresses used by this function.
MVR_PP	0,D4h	Register	MVI write page pointer.
MVW_PP	0,D5h	Register	MVI read page pointer.

PSoC devices, a BLOCKID value of '0' will checksum 256 blocks.

3.3 Register Definitions

The following registers are associated with the Supervisory ROM (SROM) and are listed in address order. The register descriptions have an associated register table showing the bit structure for that register. The bits in the tables that are grayed out are reserved bits and are not detailed in the register descriptions that follow. Reserved bits should always be written with a value of '0'. For a complete table of SROM registers, refer to the "[Summary Table of the Core Registers](#)" on page 60.

3.3.1 STK_PP Register

Address	Name	Bit 7	Bit 6	Bit 5	Bit 4	Bit 3	Bit 2	Bit 1	Bit 0	Access	
0,D1h	STK_PP							Page Bits[2:0]			RW : 00

The Stack Page Pointer Register (STK_PP) is used to set the effective SRAM page for stack memory accesses in a multi-SRAM page PSoC device. This register is only used when a device has more than one page of SRAM.

Bits 2 to 0: Page Bits[2:0]. This register has the potential to affect two types of memory access. The first type of memory access of the STK_PP register is to determine which SRAM page the stack will be stored on. In the reset state, this register's value is 0x00 and the stack will therefore be in SRAM Page 0. However, if the STK_PP register value is changed, the next stack operation will occur on the SRAM page indicated by the new STK_PP value. Therefore, the value of this register should be set early in the program and never be changed. If the program changes the STK_PP value after the stack has grown, the program must ensure that the STK_PP value is restored when needed.

Note The impact that the STK_PP has on the stack is independent of the SRAM Paging bits in the CPU_F register.

The second type of memory access of the STK_PP register affects indexed memory access when the CPU_F[7:6] bits are set to 11b. In this mode, source indexed and destination indexed memory accesses are directed to the stack SRAM page, rather than the SRAM page indicated by the IDX_PP register or SRAM Page 0.

For additional information, refer to the [STK_PP register on page 220](#).

3.3.2 MVR_PP Register

Address	Name	Bit 7	Bit 6	Bit 5	Bit 4	Bit 3	Bit 2	Bit 1	Bit 0	Access
0,D4h	MVR_PP						Page Bits[2:0]			RW : 00

The MVI Read Page Pointer Register (MVR_PP) is used to set the effective SRAM page for MVI read memory accesses in a multi-SRAM page PSoC device.

Note This register is only used when a device has more than one page of SRAM. Refer to the table titled “[PSoC Device SRAM Availability](#)” on [page 85](#) to determine the number of SRAM pages for your PSoC device.

Bits 2 to 0: Page Bits[2:0]. This register is only used by the MVI A, [expr] instruction, not to be confused with the MVI [expr], A instruction covered by the MVW_PP register. This instruction is considered a read because data is transferred from SRAM to the microprocessor's A register (CPU_A).

When an MVI A, [expr] instruction is executed in a device with more than one page of SRAM, the SRAM address that is read by the instruction is determined by the value of the least significant bits in this register. However, the pointer for the MVI A, [expr] register is always located in the current SRAM page. See the *PSoC Designer Assembly Language User Guide* for more information on the MVI A, [expr] instruction.

The function of this register and the MVI instructions are independent of the SRAM Paging bits in the CPU_F register.

For additional information, refer to the [MVR_PP register on page 222](#).

3.3.3 MVW_PP Register

Address	Name	Bit 7	Bit 6	Bit 5	Bit 4	Bit 3	Bit 2	Bit 1	Bit 0	Access
0,D5h	MVW_PP						Page Bits[2:0]			RW : 00

The MVI Write Page Pointer Register (MVW_PP) is used to set the effective SRAM page for MVI write memory accesses in a multi-SRAM page PSoC device.

Note This register is only used when a device has more than one page of SRAM.

Bits 2 to 0: Page Bits[2:0]. This register is only used by the MVI [expr], A instruction, not to be confused with the MVI A, [expr] instruction covered by the MVR_PP register. This instruction is considered a write because data is transferred from the microprocessor's A register (CPU_A) to SRAM.

When an MVI [expr], A instruction is executed in a device with more than one page of SRAM, the SRAM address that is written by the instruction is determined by the value of the least significant bits in this register. However, the pointer for the MVI [expr], A register is always located in the current SRAM page. See the *PSoC Designer Assembly Language User Guide* for more information on the MVI [expr], A instruction.

The function of this register and the MVI instructions are independent of the SRAM Paging bits in the CPU_F register.

For additional information, refer to the [MVW_PP register on page 223](#).

3.3.4 CPU_SCR1 Register

Address	Name	Bit 7	Bit 6	Bit 5	Bit 4	Bit 3	Bit 2	Bit 1	Bit 0	Access
x,FEh	CPU_SCR1	IRESS			SLIMO	ECO EXW *	ECO EX *		IRAMDIS	# : 00

LEGEND

x An "x" before the comma in the address field indicates that this register can be read or written to no matter what bank is used.

Access is bit specific. Refer to the [Register Details chapter on page 147](#) for additional information.

* Bits 3 and 2 (ECO EXW and ECO EX, respectively) cannot be used by the CY8C27x43 for silicon revision A, and by the CY8C24x23 and CY8C22x13 PSoC devices.

The System Status and Control Register 1 (CPU_SCR1) is used to convey the status and control of events related to internal resets and watchdog reset.

Bit 7: IRESS. The Internal Reset Status bit is a read only bit that can be used to determine if the booting process occurred more than once.

When this bit is set, it indicates that the SROM SWBootReset code was executed more than once. If this bit is not set, the SWBootReset was executed only once. In either case, the SWBootReset code will not allow execution from code stored in Flash until the M8C Core is in a safe operating mode with respect to supply voltage and Flash operation. There is no need for concern when this bit is set. It is provided for systems which may be sensitive to boot time, so that they can determine if the normal one-pass boot time was exceeded.

Bit 4: SLIMO. When set, the Slow IMO bit allows the active power dissipation of the PSoC device to be reduced by slowing down the IMO from 24 MHz to 6 MHz. The IMO trim value must also be changed when SLIMO is set (see "Engaging Slow IMO (SLIMO)" on page 114). When not in external clocking mode, the IMO is the source for SYSCLK; therefore, when the speed of the IMO changes, so will SYSCLK.

Bit 3: ECO EXW. The ECO Exists Written bit is used as a status bit to indicate that the ECO EX bit has been previously written to. It is read only. Note that this bit cannot be used by the CY8C27x43 for silicon revision A, and by the CY8C24x23 and CY8C22x13 PSoC devices.

Bit 2: ECO EX. The ECO Exists bit serves as a flag to the hardware, to indicate that an external crystal **oscillator** exists in the system. Just after boot, it may be written only once to a value of '1' (crystal exists) or '0' (crystal does not exist). If the bit is '0', a switch-over to the ECO is locked out by hardware. If the bit is '1', hardware allows the firmware to freely switch between the ECO and ILO. It should be written as early as possible after a **Power On Reset (POR)** or **External Reset (XRES)** event, where it is assumed that program execution integrity is high. Note that this bit cannot be used by the CY8C27x43 for silicon revision A, and by the CY8C24x23 and CY8C22x13 PSoC devices.

Bit 0: IRAMDIS. The Initialize RAM Disable bit is a control bit that is readable and writeable. The **default value** for this bit is '0', which indicates that the maximum amount of SRAM should be initialized on watchdog reset to a value of 00h. When the bit is '1', the minimum amount of SRAM is initialized after a watchdog reset. For more information on this bit, see the "SROM Function Descriptions" on page 74.

For additional information, refer to the [CPU_SCR1 register on page 251](#).

3.3.5 FLS_PR1 Register

Address	Name	Bit 7	Bit 6	Bit 5	Bit 4	Bit 3	Bit 2	Bit 1	Bit 0	Access
1,FAh	FLS_PR1							Bank[1:0]		RW : 00

The Flash Program Register 1 (FLS_PR1) is used to specify which Flash bank should be used for SROM operations.

Note This register has no effect on products with one Flash bank. Refer to the table titled “Flash Memory Organization” on page 75 to determine the number of Flash banks in PSoC devices.

Bits 1 and 0: Bank[1:0]. The Bank bits in this register indicate which Flash bank the SROM Flash functions should

operate on. The default value for the Bank bit is zero. Flash bank 0 holds up to the first 8K of user code, as well as the cal table. Note that the CY8C27x43 PSoC device holds 16K in bank 0. The optional Flash banks 1, 2, and 3 hold additional user code.

For additional information, refer to the [FLS_PR1 register on page 304](#).

3.4 Clocking

Successful programming and erase operations, on the Flash, require that the CLOCK and DELAY parameters be set correctly. To determine the proper value for the DELAY parameter only, the CPU speed must be considered. However, three factors should be used to determine the proper value for CLOCK: operating temperature, CPU speed, and characteristics of the individual device. Equations and additional information on calculating the DELAY and CLOCK values follow.

3.4.1 DELAY Parameter

To determine the proper value for the DELAY parameter, the CPU speed during the Flash operation must be considered. Equation 1 displays the equation for calculating DELAY based on a CPU speed value. In this equation the units for CPU are hertz (Hz).

$$DELAY = \frac{100 \times 10^{-6} \cdot CPU - 80}{13},$$

Equation 1

$$3MHz \leq CPU \leq 12MHz$$

Equation 2 shows the calculation of the DELAY value for a CPU speed of 12 MHz. The numerical result of this calculation should be rounded to the nearest whole number. In the case of a 12 MHz CPU speed, the correct value for DELAY is 86 (0x56).

$$DELAY = \frac{100 \times 10^{-6} \cdot 12 \times 10^6 - 80}{13}$$

Equation 2

3.4.2 CLOCK Parameter

The CLOCK parameter must be calculated using different equations for erase and write operations. The erase value for CLOCK must be calculated first. In Equation 3, the erase CLOCK value is indicated by a subscript E after the word CLOCK and the write CLOCK value is indicated by a subscript W after the word CLOCK.

Before either CLOCK value can be calculated, the values for M, B, and Mult must be determined. These are device specific values that are stored in the Flash table 3 and are accessed by way of the TableRead SROM function (see the “TableRead Function” on page 77). If the operating temperature is at or below 0°C, the cold values should be used. For operating temperatures at or above 0°C, the hot values should be used. See Table 3-11 for more information. Equations for calculating the correct value of CLOCK for write operations are first introduced with the assumption that the CPU speed is 12 MHz.

The equation for calculating the CLOCK value for an erase Flash operation is shown in Equation 3. In this equation the T has units of °C.

$$CLOCK_E = B - \frac{2M \cdot T}{256}$$

Equation 3

Using the correct values for B, M, and T, in the equation above, is required to achieve the endurance specifications of the Flash. However, for device programmers, where this calculation may be difficult to perform, the equation can be simplified by setting T to 0°C and using the hot value for B and M. This simplification is acceptable only if the total number of erase write cycles are kept to less than 10 and the operation is performed near room temperature. When T is set to 0, Equation 3 simplifies to the following.

$$CLOCK_E = B$$

Equation 4

Once a value for the erase CLOCK value has been determined, the write CLOCK value can be calculated. The equation to calculate the CLOCK value for a write is as follows.

$$CLOCK_W = \frac{CLOCK_E \cdot Mult}{64}$$

Equation 5

In the equation above, the correct value for Mult must be determined, based on temperature, in the same way that the B and M values were determined for Equation 3.

Supervisory ROM (SROM)

4. RAM Paging



This chapter explains the PSoC device's use of RAM Paging and its associated registers. For a complete table of the RAM Paging registers, refer to the "Summary Table of the Core Registers" on page 60. For a quick reference of all PSoC registers in address order, refer to the Register Details chapter on page 147.

4.1 Architectural Description

The M8C is an 8-bit CPU with an 8-bit address bus. The 8-bit memory address bus allows the M8C to access up to 256 bytes of SRAM, to increase the amount of available SRAM and preserve the M8C *assembly* language. PSoC devices with more than 256 bytes of SRAM have a paged memory architecture.

The first three of these areas have no dependency on the CPU_F register's PgMode bits and are covered in the next subsections after Basic Paging. The function of the last two depend on the CPU_F PgMode bits and will be covered last.

Table 4-1. PSoC Device SRAM Availability

PSoC Device	Amount of SRAM	Number of Pages
CY8C29x66 CY8CPLC20 CY8CLED16P01 CY8CNP1xx	2 KB	8 Pages
CY8C27x43	256 Bytes	1 Page
CY8C24x94	1 KB	4 Pages
CY8C24x23	256 Bytes	1 Page
CY8C24x23A	256 Bytes	1 Page
CY8C22x13	256 Bytes	1 Page
CY8C21x34	512 Bytes	2 Pages
CY8C21x23	256 Bytes	1 Page
CY7C64215	1 KB	4 Pages
CY7C603xx	512 Bytes	2 Pages
CYWUSB6953	512 Bytes	2 Pages

To take full advantage of the paged memory architecture of the PSoC device, several registers must be used and two CPU_F register bits must be managed. However, the Power On Reset (POR) value for all of the paging registers and CPU_F bits is zero. This places the PSoC device in a mode identical to PSoC devices with only 256 bytes of SRAM. It is not necessary to understand all of the Paging registers to take advantage of the additional SRAM available in some devices. Very simple modifications to the reset state of the memory paging logic can be made, to begin to take advantage of the additional SRAM pages.

The memory paging architecture consists of five areas:

- Stack Operations
- Interrupts
- MVI Instructions
- Current Page Pointer
- Indexed Memory Page Pointer

4.1.1 Basic Paging

The M8C is an 8-bit CPU with an 8-bit memory address bus. The memory address bus allows the M8C to access up to 256 bytes of SRAM. To increase the amount of SRAM, the M8C accesses memory page bits. The memory page bits are located in the CUR_PP register and allow for selection of one of eight SRAM pages. In addition to setting the page bits, Page mode must be enabled by setting the CPU_F[7]

bit. If Page mode is not enabled, the page bits are ignored and all non-stack memory access is directed to Page 0.

Once Page mode is enabled and the page bits are set, all instructions that operate on memory access the SRAM page indicated by the page bits. The exceptions to this are the instructions that operate on the stack and the MVI instructions: PUSH, POP, LCALL, RETI, RET, CALL, and MVI. See the description of [Stack Operations](#) and [MVI Instructions](#) below for a more detailed discussion.

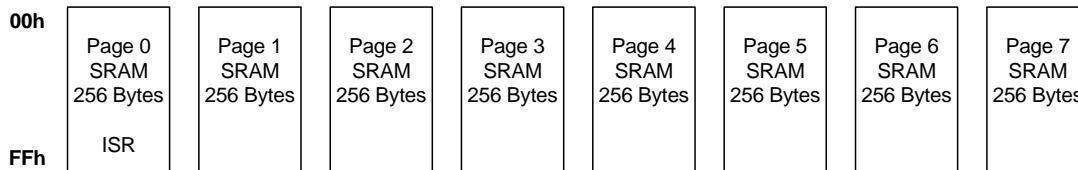

Figure 4-1. Data Memory Organization

4.1.2 Stack Operations

As mentioned previously, the paging architecture's reset state puts the PSoC in a mode that is identical to that of a 256 byte PSoC device. Therefore, upon reset, all memory accesses will be to Page 0. The SRAM page that stack operations will use is determined by the value of the three least significant bits of the stack page pointer register (STK_PP). Stack operations have no dependency on the PgMode bits in the CPU_F register. Stack operations are those that use the Stack Pointer (SP) to calculate their affected address. Refer to the *PSoC Designer Assembly Language User Guide* for more information on all M8C instructions.

Stack memory accesses must be treated as a special case. If they are not, the stack could be fragmented across several pages. To prevent the stack from becoming fragmented, all instructions that operate on the stack automatically use the page indicated by the STK_PP register. Therefore, if a CALL is encountered in the program, the PSoC device will automatically push the program counter onto the stack page indicated by STK_PP. Once the program counter is pushed, the SRAM paging mode automatically switches back to the pre-call mode. All other stack operations, such as RET and POP, follow the same rule as CALL. The stack is confined to a single SRAM page and the Stack Pointer will wrap from 00h to FFh and FFh to 00h. The user code must ensure that the stack is not damaged due to stack wrapping.

Because the value of the STK_PP register can be changed at any time, it is theoretically possible to manage the stack in such a way as to allow it to grow beyond one SRAM page or manage multiple stacks. However, the only supported use of the STK_PP register is when its value is set prior to the first stack operation and not changed again.

4.1.3 Interrupts

Interrupts, in a multi-page SRAM PSoC device, operate the same as interrupts in a 256 byte PSoC device. However, because the CPU_F register is automatically set to 0x00 on an interrupt and because of the non-linear nature of interrupts in a system, other parts of the PSoC memory paging architecture can be affected.

Interrupts are an abrupt change in program flow. If no special action is taken on interrupts by the PSoC device, the **interrupt service routine (ISR)** could be thrown into any SRAM page. To prevent this problem, the special addressing modes for all memory accesses, except for stack and MVI, are disabled when an ISR is entered. The special addressing modes are disabled when the CPU_F register is cleared. At the end of the ISR, the previous SRAM addressing mode is restored when the CPU_F register value is restored by the RETI instruction.

Therefore, all interrupt service **routine** code will start execution in SRAM Page 0. If it is necessary for the ISR to change to another SRAM page, it can be accomplished by changing the values of the CPU_F[7:6] bits to enable the special SRAM addressing modes. However, any change made to the CUR_PP, IDX_PP, or STK_PP registers will persist after the ISR returns. Therefore, the ISR should save the current value of any paging register it modifies and restore its value before the ISR returns.

4.1.4 MVI Instructions

MVI instructions use data page pointers of their own (MVR_PP and MVW_PP). This allows a data buffer to be located away from other program variables, but accessible without changing the Current Page Pointer (CUR_PP).

An MVI instruction performs three memory operations. Both forms of the MVI instruction access an address in SRAM that holds the data pointer (a memory read 1st access), incrementing that value and then storing it back in SRAM (a memory write 2nd access). This pointer value must reside in the current page, just as all other non-stack and non-indexed operations on memory must. However, the third memory operation uses the MVx_PP register. This third memory access can be either a read or a write, depending on which MVI instruction is used. The MVR_PP pointer is used for the MVI instruction that moves data into the accumulator. The MVW_PP pointer is used for the MVI instruction that moves data from the accumulator into SRAM. The MVI pointers are always enabled, regardless of the state of the Flag register page bits (CPU_F register).

4.1.5 Current Page Pointer

The Current Page Pointer is used to determine which SRAM page should be used for all memory accesses. Normal memory accesses are those not covered by other pointers including all non-stack, non-MVI, and non-indexed memory access instructions. The normal memory access instructions have the SRAM page they operate on determined by the value of the CUR_PP register. By default, the CUR_PP register has no effect on the SRAM page that will be used for normal memory access, because all normal memory access is forced to SRAM Page 0.

The upper bit of the PgMode bits in the CPU_F register determine whether or not the CUR_PP register affects normal memory access. When the upper bit of the PgMode bits is set to '0', all normal memory access is forced to SRAM Page 0. This mode is automatically enabled when an Interrupt Service Routine (ISR) is entered. This is because, before the ISR is entered, the M8C pushes the current value of the CPU_F register onto the stack and then clears the CPU_F register. Therefore, by default, any normal memory access in an ISR is guaranteed to occur in SRAM Page 0.

When the RETI instruction is executed, to end the ISR, the previous value of the CPU_F register is restored, restoring the previous page mode. Note that this ISR behavior is the default and that the PgMode bits in the CPU_F register can be changed while in an ISR. If the PgMode bits are changed while in an ISR, the pre-ISR value is still restored by the RETI; but if the CUR_PP register is changed in the ISR, the ISR is also required to restore the value before executing the RETI instruction.

When the upper bit of the PgMode bits is set to '1', all normal memory access is forced to the SRAM page indicated by the value of the CUR_PP register. [Table 4-2](#) gives a summary of the PgMode bit values and the corresponding Memory Paging mode.

4.1.6 Index Memory Page Pointer

The source indexed and destination indexed addressing modes to SRAM are treated as a unique addressing mode in a PSoC device, with more than one page of SRAM. An example of an indexed addressing mode is the MOV A, [X+expr] instruction. Note that register access also has indexed addressing; however, those instructions are not affected by the SRAM paging architecture.

Important Note If you are not using assembly to program a PSoC device, be aware that the **compiler** writer may restrict the use of some memory paging modes. Review the conventions in your compiler's user guide for more information on restrictions or conventions associated with memory paging modes.

Indexed SRAM accesses operate in one of three modes:

- Index memory access modes are forced to SRAM Page 0.

- Index memory access modes are directed to the SRAM page indicated by the value in the STK_PP register.
- Index memory access is forced to the SRAM page indicated by the value in the IDX_PP register.

The mode is determined by the value of the PgMode bits in the CPU_F register. However, the final SRAM page that is used also requires setting either the Stack Page Pointer (STK_PP) register or the Index Page Pointer (IDX_PP) register. Table 4-2 shows the three indexed memory access modes. The third column of the table is provided for reference only.

Table 4-2. CPU_F PgMode Bit Modes

CPU_F PgMode Bits	Current SRAM Page	Indexed SRAM Page	Typical Use
00b	0	0	ISR*
01b	0	STK_PP	ISR with variables on stack
10b	CUR_PP	IDX_PP	
11b	CUR_PP	STK_PP	

* Mode used by SRAM functions initiated by SSC instruction.

After reset, the PgMode bits are set to 00b. In this mode, index memory accesses are forced to SRAM Page 0, just as they would be in a PSoC device with only 256 bytes of SRAM. This mode is also automatically enabled when an interrupt occurs in a PSoC device and is therefore considered the default ISR mode. This is because before the ISR is entered, the M8C pushes the current value of the CPU_F register on to the stack and then clears the CPU_F register. Therefore, by default, any indexed memory access in an ISR is guaranteed to occur in SRAM Page 0. When the RETI instruction is executed to end the ISR, the previous value of the CPU_F register is restored and the previous page mode is then also restored. Note that this ISR behavior is the default and that the PgMode bits in the CPU_F register may be changed while in an ISR. If the PgMode bits are changed while in an ISR, the pre-ISR value is still restored by the RETI; but if the STK_PP or IDX_PP registers are changed in the ISR, the ISR is also required to restore the values before executing the RETI instruction.

The most likely PgMode bit change, while in an ISR, is from the default value of 00b to 01b. In the 01b mode, indexed memory access is directed to the SRAM page indicated by the value of the STK_PP register. By using the PgMode, the value of the STK_PP register is not required to be modified. The STK_PP register is the register that determines which SRAM page the stack is located on. The 01b paging mode is intended to provide easy access to the stack, while in an ISR, by setting the CPU_X register (just X in the instruction format) equal to the value of SP using the MOV X, SP instruction.

The two previous paragraphs covered two of the three indexed memory access modes: STK_PP and forced to SRAM Page 0. Note, as shown in Table 4-2, that the STK_PP mode for indexed memory access is available under two PgMode settings. The 01b mode is intended for

ISR use and the 11b mode is intended for non-ISR use. The third indexed memory access mode requires the PgMode bits to be set to 10b. In this mode indexed memory access is forced to the SRAM page indicated by the value of the IDX_PP register.

4.2 Register Definitions

The following registers are associated with RAM Paging and are listed in address order. The register descriptions have an associated register table showing the bit structure for that register. The bits in the tables that are grayed out are reserved bits and are not detailed in the register descriptions that follow. Reserved bits should always be written with a value of '0'. For a complete table of RAM Paging registers, refer to the “Summary Table of the Core Registers” on page 60.

4.2.1 TMP_DRx Registers

Address	Name	Bit 7	Bit 6	Bit 5	Bit 4	Bit 3	Bit 2	Bit 1	Bit 0	Access
x,6xh	TMP_DRx	Data[7:0]								RW : 00

LEGEND

x An 'x' before the comma in the address field indicates that this register can be read or written to no matter what bank is used. An “x” after the comma in the address field indicates that there are multiple instances of the register.

The Temporary Data Registers (TMP_DR0, TMP_DR1, TMP_DR2, and TMP_DR3) are used to enhance the performance in multiple SRAM page PSoC devices.

These registers have no pre-defined function (for example, the compiler and hardware do not use these registers) and exist for the user to use as desired.

Bits 7 to 0: Data[7:0]. Due to the paged SRAM architecture of PSoC devices with more than 256 bytes of SRAM, a

value in SRAM may not always be accessible without first changing the current page. The TMP_DRx registers are readable and writable and are provided to improve the performance of multiple SRAM page PSoC devices, by supplying some register space for data that is always accessible.

For an expanded listing of the TMP_DRx registers, refer to the “Summary Table of the Core Registers” on page 60. For additional information, refer to the [TMP_DRx register on page 186](#).

4.2.2 CUR_PP Register

Address	Name	Bit 7	Bit 6	Bit 5	Bit 4	Bit 3	Bit 2	Bit 1	Bit 0	Access	
0,D0h	CUR_PP						Page Bits[2:0]				RW : 00

The Current Page Pointer Register (CUR_PP) is used to set the effective SRAM page for normal memory accesses in a multi-SRAM page PSoC device.

Note This register is only used when a device has more than one page of SRAM. Refer to the table titled “PSoC Device SRAM Availability” on page 85 to determine the number of SRAM pages in PSoC devices.

Bits 2 to 0: Page Bits[2:0]. These bits affect the SRAM page that is accessed by an instruction when the CPU_F[7:0] bits have a value of either 10b or 11b. Source indexed and destination indexed addressing modes, as well as stack instructions, are never affected by the value of the CUR_PP register. (See the STK_PP and IDX_PP registers for more information.)

The source indirect post increment and destination indirect post increment addressing modes, better known as MVI, are only partially affected by the value of the CUR_PP register. For MVI instructions, the pointer address is in the SRAM page indicated by CUR_PP, but the address pointed to may be in another SRAM page. See the MVR_PP and MVW_PP register descriptions for more information.

For additional information, refer to the [CUR_PP register on page 219](#).

4.2.3 STK_PP Register

Address	Name	Bit 7	Bit 6	Bit 5	Bit 4	Bit 3	Bit 2	Bit 1	Bit 0	Access	
0,D1h	STK_PP							Page Bits[2:0]			RW : 00

The Stack Page Pointer Register (STK_PP) is used to set the effective SRAM page for stack memory accesses in a multi-SRAM page PSoC device.

Note This register is only used when a device has more than one page of SRAM. Refer to the table titled “PSoC Device SRAM Availability” on page 85 to determine the number of SRAM pages in PSoC devices.

Bits 2 to 0: Page Bits[2:0]

These bits have the potential to affect two types of memory access.

The purpose of this register is to determine which SRAM page the stack will be stored on. In the reset state, this register's value will be 0x00 and the stack will therefore be in SRAM Page 0. However, if the STK_PP register value is changed, the next stack operation will occur on the SRAM

page indicated by the new STK_PP value. Therefore, the value of this register should be set early in the program and never be changed. If the program changes the STK_PP value after the stack has grown, the program must ensure that the STK_PP value is restored when needed.

Note that the impact that the STK_PP register has on the stack is independent of the SRAM Paging bits in the CPU_F register.

The second type of memory accesses that the STK_PP register affects are indexed memory accesses when the CPU_F[7:6] bits are set to 11b. In this mode, source indexed and destination indexed memory accesses are directed to the stack SRAM page, rather than the SRAM page indicated by the IDX_PP register or SRAM Page 0.

For additional information, refer to the [STK_PP register on page 220](#).

4.2.4 IDX_PP Register

Address	Name	Bit 7	Bit 6	Bit 5	Bit 4	Bit 3	Bit 2	Bit 1	Bit 0	Access	
0,D3h	IDX_PP							Page Bits[2:0]			RW : 00

The Index Page Pointer Register (IDX_PP) is used to set the effective SRAM page for indexed memory accesses in a multi-SRAM page PSoC device.

Note This register is only used when a device has more than one page of SRAM. Refer to the table titled “PSoC Device SRAM Availability” on page 85 to determine the number of SRAM pages in PSoC devices.

Bits 2 to 0: Page Bits[2:0].

These bits allow instructions, which use the source indexed and destination indexed address modes, to operate on an SRAM page that is not equal to the current SRAM page. However, the effect this register has on indexed addressing modes is only enabled when the CPU_F[7:6] is set to 10b.

When CPU_F[7:6] is set to 10b and an indexed memory access is made, the access is directed to the SRAM page indicated by the value of the IDX_PP register.

See the STK_PP register description for more information on other indexed memory access modes.

For additional information, refer to the [IDX_PP register on page 221](#).

4.2.5 MVR_PP Register

Address	Name	Bit 7	Bit 6	Bit 5	Bit 4	Bit 3	Bit 2	Bit 1	Bit 0	Access	
0,D4h	MVR_PP							Page Bits[2:0]			RW : 00

The MVI Read Page Pointer Register (MVR_PP) is used to set the effective SRAM page for MVI read memory accesses in a multi-SRAM page PSoC device.

Note This register is only used when a device has more than one page of SRAM. Refer to the table titled “PSoC Device SRAM Availability” on page 85 to determine the number of SRAM pages in PSoC devices.

Bits 2 to 0: Page Bits[2:0]. These bits are only used by the MVI A, [expr] instruction, not to be confused with the MVI [expr], A instruction covered by the MVW_PP register. This instruction is considered a read because data is transferred from SRAM to the microprocessor's A register (CPU_A).

When an MVI A, [expr] instruction is executed in a device with more than one page of SRAM, the SRAM address that is read by the instruction is determined by the value of the least significant bits in this register. However, the pointer for the MVI A, [expr] instruction is always located in the current SRAM page. See the *PSoC Designer Assembly Language User Guide* for more information on the MVI A, [expr] instruction.

The function of this register and the MVI instructions are independent of the SRAM Paging bits in the CPU_F register. For additional information, refer to the [MVR_PP register on page 222](#).

4.2.6 MVW_PP Register

Address	Name	Bit 7	Bit 6	Bit 5	Bit 4	Bit 3	Bit 2	Bit 1	Bit 0	Access
0,D5h	MVW_PP						Page Bits[2:0]			RW : 00

The MVI Write Page Pointer Register (MVW_PP) is used to set the effective SRAM page for MVI write memory accesses in a multi-SRAM page PSoC device.

Note This register is only used when a device has more than one page of SRAM. Refer to the table titled “[PSoC Device SRAM Availability](#)” on [page 85](#) to determine the number of SRAM pages in PSoC devices.

Bits 2 to 0: Page Bits[2:0]. These bits are only used by the MVI [expr], A instruction, not to be confused with the MVI A, [expr] instruction covered by the MVR_PP register. This instruction is considered a write because data is transferred from the microprocessor's A register (CPU_A) to SRAM.

When an MVI [expr], A instruction is executed in a device with more than one page of SRAM, the SRAM address that is written by the instruction is determined by the value of the least significant bits in this register. However, the pointer for the MVI [expr], A instruction is always located in the current SRAM page. See the *PSoC Designer Assembly Language User Guide* for more information on the MVI [expr], A instruction.

The function of this register and the MVI instructions are independent of the SRAM Paging bits in the CPU_F register. For additional information, refer to the [MVW_PP register](#) on [page 223](#).

4.2.7 CPU_F Register

Address	Name	Bit 7	Bit 6	Bit 5	Bit 4	Bit 3	Bit 2	Bit 1	Bit 0	Access
x,F7h	CPU_F	PgMode[1:0]			XIO		Carry	Zero	GIE	RL : 02

LEGEND

- L The AND F, expr; OR F, expr; and XOR F, expr flag instructions can be used to modify this register.
- x An 'x' before the comma in the address field indicates that this register can be read or written to no matter what bank is used.

The M8C Flag Register (CPU_F) provides read access to the M8C flags.

Bits 7 and 6: PgMode[1:0]. PgMode determines how the CUR_PP and IDX_PP registers are used in forming effective RAM addresses for Direct Address mode and Indexed Address mode operands.

Bit 4: XIO. The IO Bank Select bit, also known as the register bank select bit, is used to select the register bank that is active for a register read or write. This bit allows the PSoC device to have 512 8-bit registers and therefore, can be thought of as the ninth address bit for registers. The address space accessed when the XIO bit is set to '0' is called the *user space*, while the address space accessed when the XIO bit is set to '1' is called the *configuration space*.

Bit 2: Carry. The Carry Flag bit is set or cleared in response to the result of several instructions. It can also be manipulated by the flag-logic opcodes (for example, OR F, 4). See the *PSoC Designer Assembly Guide User Manual* for more details.

Bit 1: Zero. The Zero Flag bit is set or cleared in response to the result of several instructions. It can also be manipulated by the flag-logic opcodes (for example, OR F, 2). See the *PSoC Designer Assembly Guide User Manual* for more details.

Bit 0: GIE. The state of the Global Interrupt Enable bit determines whether interrupts (by way of the IRQ) will be recognized by the M8C. This bit is set or cleared by the user, using the flag-logic instructions (for example, OR F, 1). GIE is also cleared automatically by the M8C upon entering the interrupt service routine (ISR), after the flag byte has been stored on the stack, preventing nested interrupts. Note that the bit can be set in an ISR if desired.

For GIE=1, the M8C samples the IRQ input for each instruction. For GIE=0, the M8C ignores the IRQ. For additional information, refer to the [CPU_F register](#) on page 249.

5. Interrupt Controller



This chapter presents the Interrupt Controller and its associated registers. The interrupt controller provides a mechanism for a hardware resource in PSoC Programmable System-on-Chip devices, to change program execution to a new address without regard to the current task being performed by the code being executed. For a complete table of the Interrupt Controller registers, refer to the “Summary Table of the Core Registers” on page 60. For a quick reference of all PSoC registers in address order, refer to the Register Details chapter on page 147.

5.1 Architectural Description

A block diagram of the PSoC Interrupt Controller is shown in Figure 5-1, illustrating the concepts of *posted interrupts* and *pending interrupts*.

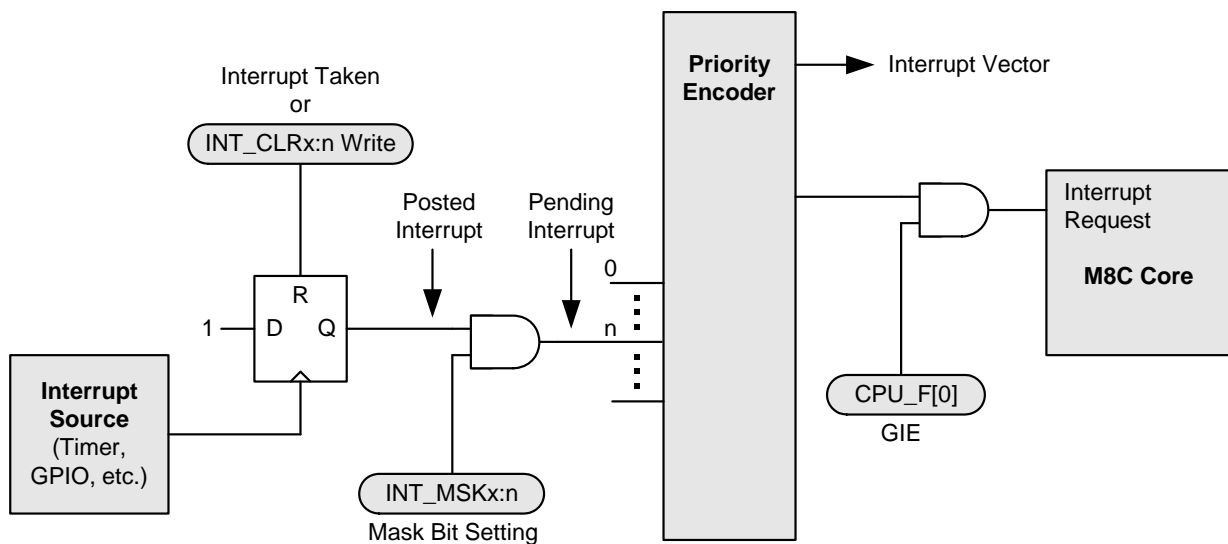

Figure 5-1. Interrupt Controller Block Diagram

The sequence of events that occur during interrupt processing is as follows.

1. An interrupt becomes active, either because (a) the interrupt condition occurs (for example, a timer expires), (b) a previously posted interrupt is enabled through an update of an interrupt *mask* register, or (c) an interrupt is pending and GIE is set from '0' to '1' in the CPU Flag register.
2. The current executing instruction finishes.
3. The internal interrupt routine executes, taking 13 cycles. During this time, the following actions occur:
 - The PCH, PCL, and Flag register (CPU_F) are pushed onto the stack (in that order).
 - The CPU_F register is then cleared. Since this clears the GIE bit to 0, additional interrupts are temporarily disabled.
 - The PCH (PC[15:8]) is cleared to zero.
 - The interrupt vector is read from the interrupt controller and its value is placed into PCL (PC[7:0]). This sets the program counter to point to the appropriate

address in the interrupt table (for example, 001Ch for the GPIO interrupt).

4. Program execution vectors to the interrupt table. Typically, a LJMP instruction in the interrupt table sends execution to the user's interrupt service routine (ISR) for this interrupt. (See "Instruction Set Summary" on page 64.)
5. The ISR executes. Note that interrupts are disabled since GIE = 0. In the ISR, interrupts can be re-enabled if desired, by setting GIE = 1 (take care to avoid stack overflow in this case).
6. The ISR ends with a RETI instruction. This pops the Flag register, PCL, and PCH from the stack, restoring those registers. The restored Flag register re-enables interrupts, since GIE = 1 again.
7. Execution resumes at the next instruction, after the one that occurred before the interrupt. However, if there are more pending interrupts, the subsequent interrupts will be processed before the next normal program instruction.

Interrupt Latency. The time between the assertion of an enabled interrupt and the start of its ISR can be calculated using the following equation:

$$\begin{aligned} \text{Latency} = & \quad \text{Equation 1} \\ & \text{Time for current instruction to finish} + \\ & \text{Time for M8C to change program counter to interrupt address} + \\ & \text{Time for LJMP instruction in interrupt table to execute.} \end{aligned}$$

For example, if the 5-cycle JMP instruction is executing when an interrupt becomes active, the total number of CPU clock cycles before the ISR begins would be as follows:

$$\begin{aligned} & (1 \text{ to } 5 \text{ cycles for JMP to finish}) + \quad \text{Equation 2} \\ & (13 \text{ cycles for interrupt routine}) + \\ & (7 \text{ cycles for LJMP}) = 21 \text{ to } 25 \text{ cycles.} \end{aligned}$$

In the example above, at 24 MHz, 25 clock cycles take 1.042 μs.

Interrupt Priority. The priorities of the interrupts only come into consideration if more than one interrupt is pending during the same instruction cycle. In this case, the priority encoder (see Figure 5-1) generates an interrupt vector for the highest priority interrupt that is pending.

5.1.1 Posted versus Pending Interrupts

An interrupt is posted when its interrupt conditions occur. This results in the flip-flop in Figure 5-1 clocking in a '1'. The interrupt will remain posted until the interrupt is taken or until it is cleared by writing to the appropriate INT_CLRx register.

A posted interrupt is not pending unless it is enabled by setting its interrupt mask bit (in the appropriate INT_MSKx register). All pending interrupts are processed by the Priority Encoder to determine the highest priority interrupt which will be taken by the M8C if the Global Interrupt Enable bit is set in the CPU_F register.

Disabling an interrupt by clearing its interrupt mask bit (in the INT_MSKx register) does not clear a posted interrupt, nor does it prevent an interrupt from being posted. It simply prevents a posted interrupt from becoming pending.

It is especially important to understand the functionality of clearing posted interrupts, if the configuration of the PSoC device is changed by the application.

For example, if a digital PSoC block is configured as a counter and has posted an interrupt but is later reconfigured to a serial communications receiver, the posted interrupt from the counter will remain. Therefore, if the digital PSoC block's INT_MSKx bit is set after configuring the block as a serial communications receiver, a pending interrupt is generated immediately. To prevent the carryover of posted interrupts from one configuration to the next, the INT_CLRx registers should be used to clear posted interrupts prior to enabling the digital PSoC block.

5.2 Application Description

The interrupt controller and its associated registers allow the user's code to respond to an interrupt from almost every functional block in the PSoC devices. Interrupts for all the digital blocks and each of the analog columns are available, as well as interrupts for supply voltage, sleep, variable clocks, and a general GPIO (pin) interrupt.

The registers associated with the interrupt controller allow interrupts to be disabled either globally or individually. The registers also provide a mechanism by which a user can

clear all pending and posted interrupts, or clear individual posted or pending interrupts. A **software** mechanism is provided to set individual interrupts. Setting an interrupt by way of software is very useful during code development, when one may not have the complete hardware system necessary to generate a real interrupt.

The following table lists the interrupts for all PSoC devices and the priorities that are available in each PSoC device.

Table 5-1. PSoC Device Interrupt Table

Interrupt Priority	Interrupt Address	PSoC Devices CY8 –								PSoC Devices CY7 –		CY8CNP1xx	Interrupt Name
		C29x66	C27x43	C24x94	C24x23	C24x23A	C22x13	C21x34	C21x23	C64215	C603xx		
0 (Highest)	0000h	✓	✓	✓	✓	✓	✓	✓	✓	✓	✓	✓	Reset
1	0004h	✓	✓	✓	✓	✓	✓	✓	✓	✓	✓	✓	Supply Voltage Monitor (LVD)
2	0008h	✓	✓	✓	✓	✓		✓	✓	✓	✓	✓	Analog Column 0
3	000Ch	✓	✓	✓	✓	✓	✓	✓	✓	✓	✓	✓	Analog Column 1
4	0010h	✓	✓									✓	Analog Column 2
5	0014h	✓	✓									✓	Analog Column 3
6	0018h	✓	✓	✓	✓	✓	✓	✓	✓	✓	✓	✓	VC3
7	001Ch	✓	✓	✓	✓	✓	✓	✓	✓	✓	✓	✓	GPIO
8	0020h	✓	✓	✓	✓	✓	✓	✓	✓	✓	✓	✓	PSoC Block DBB00
9	0024h	✓	✓	✓	✓	✓	✓	✓	✓	✓	✓	✓	PSoC Block DBB01
10	0028h	✓	✓	✓	✓	✓	✓	✓	✓	✓	✓	✓	PSoC Block DCB02
11	002Ch	✓	✓	✓	✓	✓	✓	✓	✓	✓	✓	✓	PSoC Block DCB03
12	0030h	✓	✓									✓	PSoC Block DBB10
13	0034h	✓	✓									✓	PSoC Block DBB11
14	0038h	✓	✓									✓	PSoC Block DCB12
15	003Ch	✓	✓									✓	PSoC Block DCB13
16	0040h	✓		USB Bus Reset						USB Bus Reset		✓	PSoC Block DBB20
17	0044h	✓		USB Start of Frame						USB Start of Frame		✓	PSoC Block DBB21
18	0048h	✓		USB Endpoint 0						USB Endpoint 0		✓	PSoC Block DCB22
19	004Ch	✓		USB Endpoint 1						USB Endpoint 1		✓	PSoC Block DCB23
20	0050h	✓		USB Endpoint 2						USB Endpoint 2		✓	PSoC Block DBB30
21	0054h	✓		USB Endpoint 3						USB Endpoint 3		✓	PSoC Block DBB31
22	0058h	✓		USB Endpoint 4						USB Endpoint 4		✓	PSoC Block DCB32
23	005Ch	✓		USB Wakeup Interrupt						USB Wakeup Interrupt		✓	PSoC Block DCB33
24	0060h	✓	✓	✓	✓	✓	✓	✓	✓	✓	✓	✓	I2C
25 (Lowest)	0064h	✓	✓	✓	✓	✓	✓	✓	✓	✓	✓	✓	Sleep Timer

5.3 Register Definitions

The following registers are associated with the Interrupt Controller and are listed in address order. The register descriptions have an associated register table showing the bit structure for that register. The bits in the tables that are grayed out are reserved bits and are not detailed in the register descriptions that follow. Reserved bits should always be written with a value of '0'. For a complete table of Interrupt Controller registers, refer to the “Summary Table of the Core Registers” on page 60.

Depending on the PSoC device you have, only certain bits are accessible to be read or written, such as the INT_CLR0 and INT_MSK0 registers that are analog column and digital row dependent. The analog column dependent registers have the column number listed to the right of the Address column. The digital row dependent registers are set up the same way, only with the term “Row” in the Address column. To determine your PSoC’s characteristics, refer to the table titled “PSoC Device Characteristics” on page 22.

5.3.1 INT_CLRx Registers

Address	Name	Bit 7	Bit 6	Bit 5	Bit 4	Bit 3	Bit 2	Bit 1	Bit 0	Access
0,DAh 4 Cols.	INT_CLR0	VC3	Sleep	GPIO	Analog 3	Analog 2	Analog 1	Analog 0	V Monitor	RW : 00
		VC3	Sleep	GPIO			Analog 1	Analog 0	V Monitor	
		VC3	Sleep	GPIO			Analog 1		V Monitor	
0,DBh 4, 2 Rows	INT_CLR1	DCB13	DCB12	DBB11	DBB10	DCB03	DCB02	DBB01	DBB00	RW : 00
						DCB03	DCB02	DBB01	DBB00	
0,DCh 4 Rows	INT_CLR2	DCB33	DCB32	DBB31	DBB30	DCB23	DCB22	DBB21	DBB20	RW : 00
		Wakeup Interrupt	Endpoint 4	Endpoint 3	Endpoint 2	Endpoint 1	Endpoint 0	Start of Frame	Bus Reset	
0,DDh	INT_CLR3								I2C	RW : 00

The Interrupt Clear Registers (INT_CLRx) are used to enable the individual interrupt sources’ ability to clear posted interrupts.

There are four interrupt clear registers (INT_CLR0, INT_CLR1, INT_CLR2, and INT_CLR3) which may be referred to in general as INT_CLRx. The INT_CLRx registers are similar to the INT_MSKx registers in that they hold a bit for each interrupt source. Functionally the INT_CLRx registers are similar to the INT_VC register, although their operation is completely independent. When an INT_CLRx register is read, any bits that are set indicates an interrupt has been posted for that hardware resource. Therefore, reading these registers gives the user the ability to determine all posted interrupts.

The Enable Software Interrupt (ENSWINT) bit in INT_MSK3[7] determines the way an individual bit value written to an INT_CLR0 register is interpreted. When ENSWINT is cleared (the default state), writing 1’s to an INT_CLRx register has no effect. However, writing 0’s to an INT_CLRx register, when ENSWINT is cleared, will cause the corresponding interrupt to clear. If the ENSWINT bit is set, any 0’s written to the INT_CLRx registers are ignored. However, 1’s written to an INT_CLRx register, while ENSWINT is set, will cause an interrupt to post for the corresponding interrupt.

Note When using the INT_CLRx register to post an interrupt, the hardware interrupt source, such as a digital clock, must not have its interrupt output high. Therefore, it may be

difficult to use software interrupts with interrupt sources that do not have enables such as VC3.

Software interrupts can aid in debugging interrupt service routines by eliminating the need to create system level interactions that are sometimes necessary to create a hardware-only interrupt.

5.3.1.1 INT_CLR0 Register

Depending on the analog column configuration of your PSoC device (see the table titled “PSoC Device Characteristics” on page 22), some bits may not be available in the INT_CLR0 register.

Bit 7: VC3. This bit allows posted VC3 interrupts to be read, cleared, or set.

Bit 6: Sleep. This bit allows posted sleep interrupts to be read, cleared, or set.

Bit 5: GPIO. This bit allows posted GPIO interrupts to be read, cleared, or set.

Bit 4: Analog 3. This bit allows posted analog column 3 interrupts to be read, cleared, or set.

Bit 3: Analog 2. This bit allows posted analog column 2 interrupts to be read, cleared, or set.

Bit 2: Analog 1. This bit allows posted analog column 1 interrupts to be read, cleared, or set.

Bit 1: Analog 0. This bit allows posted analog column 0 interrupts to be read, cleared, or set.

Bit 0: V Monitor. This bit allows posted V monitor interrupts to be read, cleared, or set.

For additional information, refer to the [INT_CLR0 register on page 229](#).

5.3.1.2 *INT_CLR1 Register*

Depending on the digital row configuration of your PSoC device (see the table titled “PSoC Device Characteristics” on [page 22](#)), some bits may not be available in the INT_CLR1 register.

Bit 7: DCB13. This bit allows posted DCB13 interrupts to be read, cleared, or set for row 1 block 3.

Bit 6: DCB12. This bit allows posted DCB12 interrupts to be read, cleared, or set for row 1 block 2.

Bit 5: DBB11. This bit allows posted DBB11 interrupts to be read, cleared, or set for row 1 block 1.

Bit 4: DBB10. This bit allows posted DBB10 interrupts to be read, cleared, or set for row 1 block 0.

Bit 3: DCB03. This bit allows posted DCB03 interrupts to be read, cleared, or set for row 0 block 3.

Bit 2: DCB02. This bit allows posted DCB02 interrupts to be read, cleared, or set for row 0 block 2.

Bit 1: DBB01. This bit allows posted DBB01 interrupts to be read, cleared, or set for row 0 block 1.

Bit 0: DBB00. This bit allows posted DBB00 interrupts to be read, cleared, or set for row 0 block 0.

For additional information, refer to the [INT_CLR1 register on page 231](#).

5.3.1.3 *INT_CLR2 Register*

Bit 7: DCB33. This bit allows posted DCB33 interrupts to be read, cleared, or set for row 3 block 3. USB Wakeup Interrupt for the CY8C24x94 and CY7C64215 PSoC devices.

Bit 6: DCB32. This bit allows posted DCB32 interrupts to be read, cleared, or set for row 3 block 2. USB Endpoint 4 for the CY8C24x94 and CY7C64215 PSoC devices.

Bit 5: DBB31. This bit allows posted DBB31 interrupts to be read, cleared, or set for row 3 block 1. USB Endpoint 3 for the CY8C24x94 and CY7C64215 PSoC devices.

Bit 4: DBB30. This bit allows posted DBB30 interrupts to be read, cleared, or set for row 3 block 0. USB Endpoint 2 for the CY8C24x94 and CY7C64215 PSoC devices.

Bit 3: DCB23. This bit allows posted DCB23 interrupts to be read, cleared, or set for row 2 block 3. USB Endpoint 1 for the CY8C24x94 and CY7C64215 PSoC devices.

Bit 2: DCB22. This bit allows posted DCB22 interrupts to be read, cleared, or set for row 2 block 2. USB Endpoint 0 for the CY8C24x94 and CY7C64215 PSoC devices.

Bit 1: DBB21. This bit allows posted DBB21 interrupts to be read, cleared, or set for row 2 block 1. USB Start of Frame for the CY8C24x94 and CY7C64215 PSoC devices.

Bit 0: DBB20. This bit allows posted DBB20 interrupts to be read, cleared, or set for row 2 block 0. USB Bus Reset for the CY8C24x94 and CY7C64215 PSoC devices.

For additional information, refer to the [INT_CLR2 register on page 233](#).

5.3.1.4 *INT_CLR3 Register*

Bit 0: I2C. This bit allows posted I2C interrupts to be read, cleared, or set

For additional information, refer to the [INT_CLR3 register on page 235](#).

5.3.2 INT_MSKx Registers

Address	Name	Bit 7	Bit 6	Bit 5	Bit 4	Bit 3	Bit 2	Bit 1	Bit 0	Access	
0,DEh	INT_MSK3	ENSWINT								I2C	RW : 00
0,DFh 4 Rows USB	INT_MSK2	DCB33	DCB32	DBB31	DBB30	DCB23	DCB22	DBB21	DBB20	RW : 00	
		Wakeup Interrupt	Endpoint 4	Endpoint 3	Endpoint 2	Endpoint 1	Endpoint 0	Start of Frame	Bus Reset		
0,E0h 4 Cols. 2 Cols. 1 Col.	INT_MSK0	VC3	Sleep	GPIO	Analog 3	Analog 2	Analog 1	Analog 0	V Monitor	RW : 00	
		VC3	Sleep	GPIO				Analog 1	Analog 0		V Monitor
		VC3	Sleep	GPIO				Analog 1			V Monitor
0,E1h 4, 2 Rows 1 Row	INT_MSK1	DCB13	DCB12	DBB11	DBB10	DCB03	DCB02	DBB01	DBB00	RW : 00	
							DCB03	DCB02	DBB01		DBB00

The Interrupt Mask Registers (INT_MSKx) are used to enable the individual interrupt sources' ability to create pending interrupts.

There are four interrupt **mask** registers (INT_MSK0, INT_MSK1, INT_MSK2, and INT_MSK3) which may be referred to in general as INT_MSKx. If cleared, each bit in an INT_MSKx register prevents a posted interrupt from becoming a pending interrupt (input to the priority encoder). However, an interrupt can still post even if its mask bit is zero. All INT_MSKx bits are independent of all other INT_MSKx bits.

If an INT_MSKx bit is set, the interrupt source associated with that mask bit may generate an interrupt that will become a pending interrupt. For example, if INT_MSK0[5] is set and at least one GPIO pin is configured to generate an interrupt, the interrupt controller will allow a GPIO interrupt request to post and become a pending interrupt for the M8C to respond to. If a higher priority interrupt is generated before the M8C responds to the GPIO interrupt, the higher priority interrupt will be responded to and not the GPIO interrupt.

Each interrupt source may require configuration at a block level. Refer to the other chapters in this manual for information on how to configure an individual interrupt source.

5.3.2.1 INT_MSK3 Register

Bit 7: ENSWINT. This bit is a special non-mask bit that controls the behavior of the INT_CLRx registers. See the INT_CLRx register in this section for more information.

Bit 0: I2C. This bit allows posted I2C interrupts to be read, masked, or set

For additional information, refer to the [INT_MSK3 register on page 236](#).

5.3.2.2 INT_MSK2 Register

Depending on the digital row characteristics of your PSoC device (see the table titled “[PSoC Device Characteristics](#)” on page 22), you may not be able to use this register. The bits in this register are only for PSoC devices with 4 and 3 digital rows.

Bit 7: DCB33. This bit allows posted DCB33 interrupts to be read, masked, or set for row 3 block 3. USB Wakeup Interrupt for the CY8C24x94 and CY7C64215 PSoC devices.

Bit 6: DCB32. This bit allows posted DCB32 interrupts to be read, masked, or set for row 3 block 2. USB Endpoint 4 for the CY8C24x94 and CY7C64215 PSoC devices.

Bit 5: DBB31. This bit allows posted DBB31 interrupts to be read, masked, or set for row 3 block 1. USB Endpoint 3 for the CY8C24x94 and CY7C64215 PSoC devices.

Bit 4: DBB30. This bit allows posted DBB30 interrupts to be read, masked, or set for row 3 block 0. USB Endpoint 2 for the CY8C24x94 PSoC device.

Bit 3: DCB23. This bit allows posted DCB23 interrupts to be read, masked, or set for row 2 block 3. USB Endpoint 1 for the CY8C24x94 and CY7C64215 PSoC devices.

Bit 2: DCB22. This bit allows posted DCB22 interrupts to be read, masked, or set for row 2 block 2. USB Endpoint 0 for the CY8C24x94 and CY7C64215 PSoC devices.

Bit 1: DBB21. This bit allows posted DBB21 interrupts to be read, masked, or set for row 2 block 1. USB Start of Frame for the CY8C24x94 and CY7C64215 PSoC devices.

Bit 0: DBB20. This bit allows posted DBB20 interrupts to be read, masked, or set for row 2 block 0. USB Bus Reset for the CY8C24x94 and CY7C64215 PSoC devices.

For additional information, refer to the [INT_MSK2 register on page 237](#).

5.3.2.3 INT_MSK0 Register

Depending on the analog column characteristics of your PSoC device (see the table titled “PSoC Device Characteristics” on page 22), some bits may not be available in the INT_MSK0 register.

Bit 7: VC3. This bit allows posted VC3 interrupts to be read, masked, or set.

Bit 6: Sleep. This bit allows posted sleep interrupts to be read, masked, or set.

Bit 5: GPIO. This bit allows posted GPIO interrupts to be read, masked, or set.

Bit 4: Analog 3. This bit allows posted analog column 3 interrupts to be read, masked, or set.

Bit 3: Analog 2. This bit allows posted analog column 2 interrupts to be read, masked, or set.

Bit 2: Analog 1. This bit allows posted analog column 1 interrupts to be read, masked, or set.

Bit 1: Analog 0. This bit allows posted analog column 0 interrupts to be read, masked, or set.

Bit 0: V Monitor. This bit allows posted V monitor interrupts to be read, masked, or set.

For additional information, refer to the [INT_MSK0 register on page 239](#).

5.3.2.4 INT_MSK1 Register

Depending on the digital row characteristics of your PSoC device (see the table titled “PSoC Device Characteristics” on page 22), some bits may not be available in the INT_MSK1 register. The bits in this register are available for all PSoC devices, with the exception of one digital row devices.

Bit 7: DCB13. This bit allows posted DCB13 interrupts to be read, masked, or set for row 1 block 3.

Bit 6: DCB12. This bit allows posted DCB12 interrupts to be read, masked, or set for row 1 block 2.

Bit 5: DBB11. This bit allows posted DBB11 interrupts to be read, masked, or set for row 1 block 1.

Bit 4: DBB10. This bit allows posted DBB10 interrupts to be read, masked, or set for row 1 block 0.

Bit 3: DCB03. This bit allows posted DCB03 interrupts to be read, masked, or set for row 0 block 3.

Bit 2: DCB02. This bit allows posted DCB02 interrupts to be read, masked, or set for row 0 block 2.

Bit 1: DBB01. This bit allows posted DBB01 interrupts to be read, masked, or set for row 0 block 1.

Bit 0: DBB00. This bit allows posted DBB00 interrupts to be read, masked, or set for row 0 block 0.

For additional information, refer to the [INT_MSK1 register on page 240](#).

5.3.3 INT_VC Register

Address	Name	Bit 7	Bit 6	Bit 5	Bit 4	Bit 3	Bit 2	Bit 1	Bit 0	Access
0,E2h	INT_VC	Pending Interrupt[7:0]								RC : 00

LEGEND

C Clearable register or bits.

The Interrupt Vector Clear Register (INT_VC) returns the next pending interrupt and clears all pending interrupts when written.

Bits 7 to 0: Pending Interrupt[7:0]. When the register is read, the *least significant byte (LSB)*, of the highest priority pending interrupt, is returned. For example, if the GPIO and I2C interrupts were pending and the INT_VC register was read, the value 1Ch would be read. However, if no interrupt were pending, the value 00h would be returned. This is the reset vector in the interrupt table; however, reading 00h from the INT_VC register should not be considered an indication that a system reset is pending. Rather, reading 00h from the INT_VC register simply indicates that there are no pending interrupts. The highest priority interrupt, indicated

by the value returned by a read of the INT_VC register, is removed from the list of pending interrupts when the M8C services an interrupt.

Reading the INT_VC register has limited usefulness. If interrupts are enabled, a read to the INT_VC register would not be able to determine that an interrupt was pending before the interrupt was actually taken. However, while in an interrupt, a user may wish to read the INT_VC register to see what the next interrupt will be. When the INT_VC register is written, with any value, all pending and posted interrupts are cleared by asserting the clear line for each interrupt.

For additional information, refer to the [INT_VC register on page 241](#).

5.3.4 CPU_F Register

Address	Name	Bit 7	Bit 6	Bit 5	Bit 4	Bit 3	Bit 2	Bit 1	Bit 0	Access
x,F7h	CPU_F	PgMode[1:0]			XIO		Carry	Zero	GIE	RL : 02

LEGEND

L The AND F, expr; OR F, expr; and XOR F, expr flag instructions can be used to modify this register.

x An "x" before the comma in the address field indicates that this register can be read or written to no matter what bank is used.

The M8C Flag Register (CPU_F) provides read access to the M8C flags. Note that only the GIE (Global Interrupt Enable) bit is related to the interrupt controller.

Bits 7 to 1. The CPU_F register holds bits that are used by different resources. For information on the other bits in this register, refer to the [CPU Core \(M8C\) chapter on page 63](#).

Bit 0: GIE. The state of the Global Interrupt Enable bit determines whether interrupts (by way of the IRQ) will be recognized by the M8C. This bit is set or cleared by the user,

using the flag-logic instructions (for example, OR F, 1). GIE is also cleared automatically by the M8C upon entering the interrupt service routine (ISR), after the flag byte has been stored on the stack, preventing nested interrupts. Note that the bit can be set in an ISR if desired.

For GIE=1, the M8C samples the IRQ input for each instruction. For GIE=0, the M8C ignores the IRQ.

For additional information, refer to the [CPU_F register on page 249](#).

6. General Purpose IO (GPIO)



This chapter discusses the General Purpose IO (GPIO) and its associated registers, which is the circuit responsible for interfacing to the IO pins of a PSoC device. The GPIO blocks provide the interface between the M8C core and the outside world. They offer a large number of configurations to support several types of *input/output (IO)* operations for both digital and analog systems. For a complete table of the GPIO registers, refer to the “[Summary Table of the Core Registers](#)” on page 60. For a quick reference of all PSoC registers in address order, refer to the [Register Details](#) chapter on page 147.

6.1 Architectural Description

The GPIO contains input buffers, output drivers, register bit storage, and configuration logic for connecting the PSoC device to the outside world.

IO Ports are arranged with (up to) 8 bits per port. Each full port contains eight identical GPIO blocks, with connections to identify a unique address and register bit number for each block. Each GPIO block can be used for the following types of IO:

- Digital IO (digital input and output controlled by software)
- Global IO (digital PSoC block input and output)
- Analog IO (analog PSoC block input and output)

Each IO pin also has several drive modes, as well as interrupt capabilities. While all GPIO pins are identical and provide digital IO, some pins may not connect internally to analog functions.

The main block diagram for the GPIO block is shown in [Figure 6-1](#). Note that some pins do not have all of the functionality shown, depending on internal connections.

The CY8C21x34, CY7C603xx, and CYWUSB6953 PSoC devices contain an enhanced capability to connect any GPIO to an internal analog bus. This is described in detail in the [IO Analog Multiplexer](#) chapter on page 517.

6.1.1 Digital IO

One of the basic operations of the GPIO ports is to allow the M8C to send information out of the PSoC device and get information into the M8C from outside the PSoC device. This is accomplished by way of the port data register (PRTxDR). Writes from the M8C to the PRTxDR register store the data state, one bit per GPIO. In the standard non-bypass mode, the pin drivers drive the pin in response to this data bit, with a drive strength determined by the Drive mode setting (see [Figure 6-1](#)). The actual voltage on the pin depends on the Drive mode and the external *load*.

The M8C can read the value of a port by reading the PRTxDR register address. When the M8C reads the PRTxDR register address, the current value of the pin voltage is translated into a logic value and returned to the M8C. Note that the pin voltage can represent a different logic value than the last value written to the PRTxDR register. This is an important distinction to remember in situations such as the use of a read modify write to a PRTxDR register. Examples of read modify write instructions include **AND**, **OR**, and **XOR**.

The following is an example of how a read modify write, to a PRTxDR register, could have an unexpected and even indeterminate result in certain systems. Consider a scenario where all bits of Port 1 on the PSoC device are in the strong 1 resistive 0 drive mode; so that in some cases, the system the PSoC is in may pull up one of the bits.

```
mov  reg[PRT1DR], 0x00
or   reg[PRT1DR], 0x80
```

In the first line of code above, writing a 0x00 to the port will not affect any bits that happen to be driven by the system the PSoC is in. However, in the second line of code, it can not guarantee that only bit 7 will be the one set to a strong 1. Because the OR instruction will first read the port, any bits that are in the pull up state will be read as a '1'. These ones will then be written back to the port. When this happens, the pin will go in to a strong 1 state; therefore, if the pull up condition ends in the system, the PSoC will keep the pin value at a logic 1.

6.1.2 Global IO

The GPIO ports are also used to interconnect signals to and from the digital PSoC blocks, as global inputs or outputs.

The global IO feature of each GPIO (port pin) is off by default. To access the feature, two parameters must be changed. To configure a GPIO as a global input, the port global select bit must be set for the desired GPIO using the PRTxGS register. This sets $BYP = 1$ in [Figure 6-1](#) and disconnects the output of the PRTxDR register from the pin. Also, the Drive mode for the GPIO must be set to the digital High Z state. (Refer to the “PRTxDMx Registers” on [page 109](#) for more information.) To configure a GPIO as a global output, the port global select bit must again be set. But in this case, the drive state must be set to any of the non-High Z states.

6.1.3 Analog Input

Analog signals can pass into the PSoC device core from PSoC device pins through the block's AOUT pin. This provides a resistive **path** (~300 ohms) directly through the GPIO block. For analog modes, the GPIO block is typically configured into a High **impedance** Analog Drive mode (High Z). The mode turns off the Schmitt trigger on the input path, which may reduce power consumption and decrease internal switching noise when using a particular IO as an analog input. Refer to the Electrical Specifications chapter in the individual PSoC device data sheet.

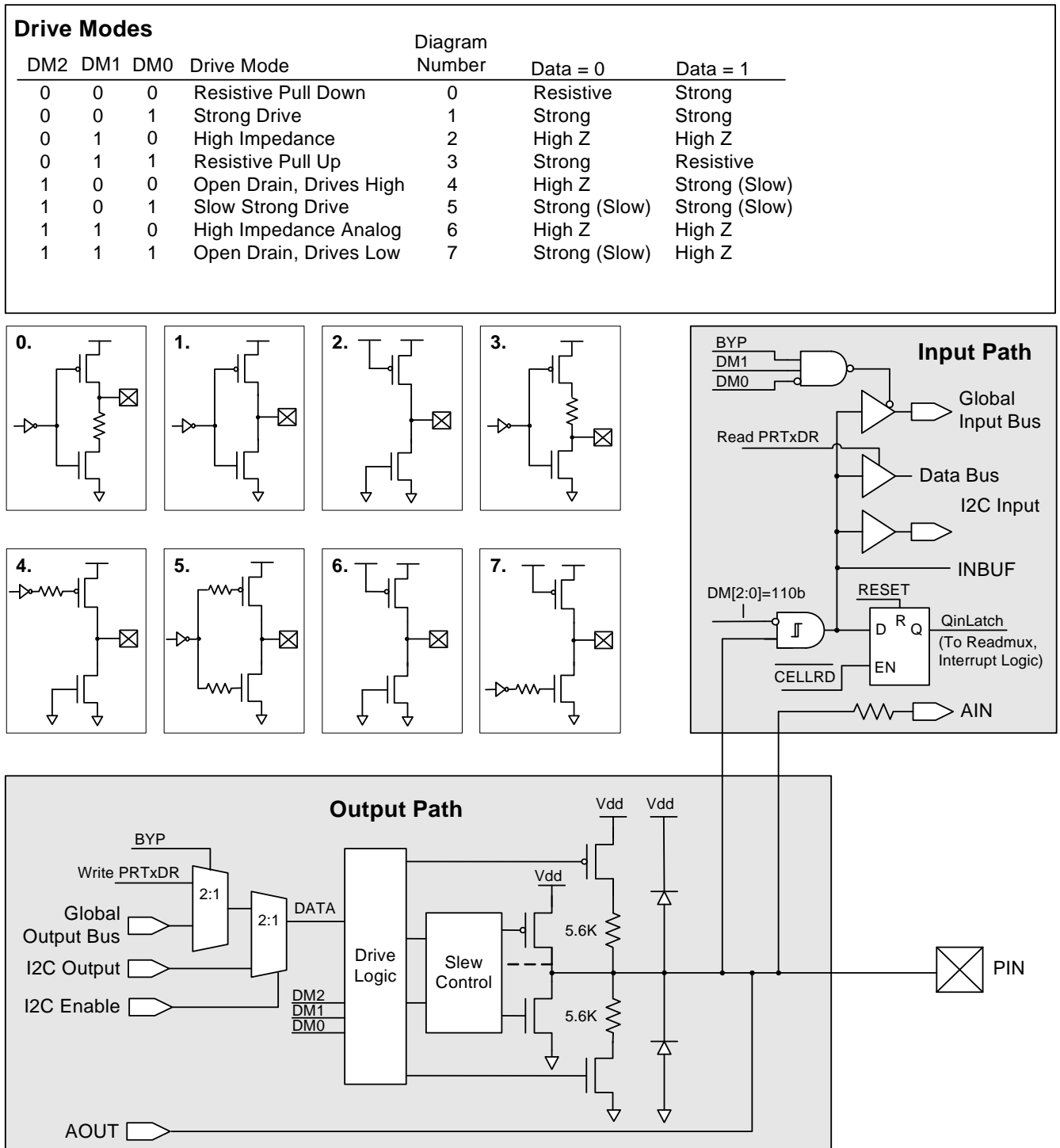

Figure 6-1. GPIO Block Diagram

6.1.4 GPIO Block Interrupts

Each GPIO block can be individually configured for interrupt capability. Blocks are configured by pin interrupt enables and also by selection of the interrupt state. Blocks can be set to interrupt when the pin is high, low, or when it changes from the last time it was read. The block provides an open-drain interrupt output (INTO) that is connected to other GPIO blocks in a wire-OR fashion.

All pin interrupts that are wire-OR'ed together are tied to the same system GPIO interrupt. Therefore, if interrupts are enabled on multiple pins, the user's interrupt service routine must provide a mechanism to determine which pin was the source of the interrupt.

Using a GPIO interrupt requires the following steps:

1. Set the Interrupt mode in the GPIO pin block.
2. Enable the bit interrupt in the GPIO block.
3. Set the mask bit for the (global) GPIO interrupt.
4. Assert the overall Global Interrupt Enable.

The first two steps, bit interrupt enable and Interrupt mode, are set at the GPIO block level (that is, at each port pin), by way of the block's configuration registers.

The last two steps are common to all interrupts and are described in the [Interrupt Controller chapter on page 95](#).

At the GPIO block level, asserting the INTO line depends only on the bit interrupt enable and the state of the pin relative to the chosen Interrupt mode. At the PSoC device level, due to their wire-OR nature, the GPIO interrupts are neither true edge-sensitive interrupts nor true level-sensitive inter-

rupts. They are considered edge-sensitive for asserting, but level-sensitive for release of the wire-OR interrupt line.

If no GPIO interrupts are asserting, a GPIO interrupt will occur whenever a GPIO pin interrupt enable is set and the GPIO pin transitions, if not already transitioned, appropriately high or low, to match the interrupt mode configuration. Once this happens, the INTO line will pull low to assert the GPIO interrupt. This assumes the other system-level enables are on, such as setting the global GPIO interrupt enable and the Global Interrupt Enable. Setting the pin interrupt enable may immediately assert INTO, if the Interrupt mode conditions are already being met at the pin.

Once INTO pulls low, it will continue to hold INTO low until one of these conditions change: (a) the pin interrupt enable is cleared; (b) the voltage at pin transitions to the opposite state; (c) in interrupt-on-change mode, the GPIO data register is read, thus setting the local interrupt level to the opposite state; or (d) the Interrupt mode is changed so that the current pin state does not create an interrupt. Once one of these conditions is met, the INTO releases. At this point, another GPIO pin (or this pin again) could assert its INTO pin, pulling the common line low to assert a new interrupt.

Note the following behavior from this level-release feature. If one pin is asserting INTO and then a second pin asserts its INTO, when the first pin releases its INTO, the second pin is already driving INTO and thus no change is seen (that is, no new interrupt would be asserted on the GPIO interrupt). Care must be taken, using polling or the states of the GPIO pin and Global Interrupt Enables, to catch all interrupts among a set of wire-OR GPIO blocks.

Figure 6-2 shows the interrupt logic portion of the block.

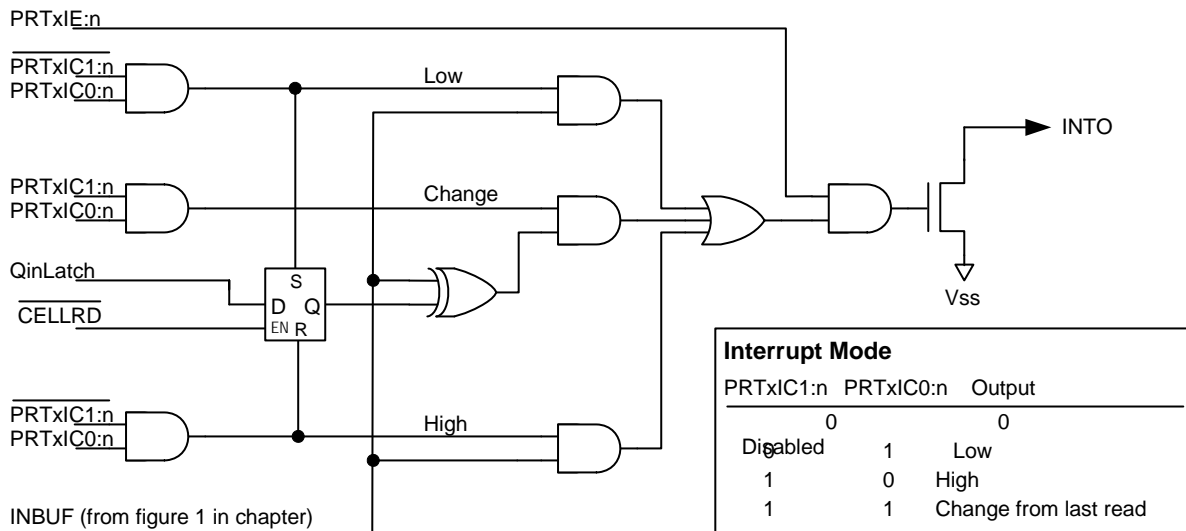

Figure 6-2. GPIO Interrupt Logic Diagram

6.2 Register Definitions

The following registers are associated with the General Purpose IO (GPIO) and are listed in address order. The register descriptions in this section have an associated register table showing the bit structure for that register. For a complete table of GPIO registers, refer to the “[Summary Table of the Core Registers](#)” on page 60.

For a selected GPIO block, the individual registers are addressed in the [Summary Table of the Core Registers](#). In the register names, the ‘x’ is the port number, configured at the PSoC device level (x = 0 to 7 typically). All register values are readable, except for the PRTxDR register; reads of this register return the pin state instead of the register bit state.

6.2.1 PRTxDR Registers

Address	Name	Bit 7	Bit 6	Bit 5	Bit 4	Bit 3	Bit 2	Bit 1	Bit 0	Access
0,xxh	PRTxDR	Data[7:0]								RW : 00

LEGEND

xx An “x” after the comma in the address field indicates that there are multiple instances of the register. For an expanded address listing of these registers, refer to the “[Core Register Summary](#)” on page 60.

The Port Data Register (PRTxDR) allows for write or read access of the current logical equivalent of the voltage on the pin.

Note The CY8C21x34, CY7C603xx, and CYWUSB6953 have a 4-bit wide Port 3.

Bits 7 to 0: Data[7:0]. Writing the PRTxDR register bits set the output drive state for the pin to high (for DIN=1) or low (DIN=0), unless a bypass mode is selected (either I2C Enable=1 or the global select register written high).

Note The CY8CNP1xx has a 2 bit wide port 3. Use caution to make certain that the nonavailable I/O bits are masked while accessing the data register for this port.

Reading the PRTxDR register returns the actual pin state, as seen by the input buffer. This may not be the same as the expected output state, if the load pulls the pin more strongly than the pin's configured output drive. See “[Digital IO](#)” on [page 103](#) for a detailed discussion of digital IO.

For additional information, refer to the [PRTxDR register](#) on [page 149](#).

6.2.2 PRTxIE Registers

Address	Name	Bit 7	Bit 6	Bit 5	Bit 4	Bit 3	Bit 2	Bit 1	Bit 0	Access
0,xxh	PRTxIE	Interrupt Enables[7:0]								RW : 00

LEGEND

xx An "x" after the comma in the address field indicates that there are multiple instances of the register. For an expanded address listing of these registers, refer to the "Core Register Summary" on page 60.

The Port Interrupt Enable Register (PRTxIE) is used to enable/disable the interrupt enable internal to the GPIO block.

Note The CY8C21x34, CY7603xx, and CYWUSB6953 have a 4-bit wide Port 3. The Cy8CNP1xx has a 2 bit wide port 3. Use caution to make certain that the nonavailable I/O bits are masked while accessing the data register for this port.

Bits 7 to 0: Interrupt Enables[7:0]. A '1' enables the INTO output at the block and a '0' disables INTO so it is only High Z.

For additional information, refer to the [PRTxIE register on page 150](#).

6.2.3 PRTxGS Registers

Address	Name	Bit 7	Bit 6	Bit 5	Bit 4	Bit 3	Bit 2	Bit 1	Bit 0	Access
0,xxh	PRTxGS	Global Select[7:0]								RW : 00

LEGEND

xx An "x" after the comma in the address field indicates that there are multiple instances of the register. For an expanded address listing of these registers, refer to the "Core Register Summary" on page 60.

The Port Global Select Register (PRTxGS) is used to select the block for connection to global inputs or outputs.

Note The CY8C21x34, CY7603xx, and CYWUSB6953 have a 4-bit wide Port 3. The Cy8CNP1xx has a 2 bit wide port 3. Use caution to make certain that the nonavailable I/O bits are masked while accessing the data register for this port.

Bits 7 to 0: Global Select[7:0]. Writing this register high enables the global bypass (BYP = 1 in [Figure 6-1](#)). If the Drive mode is set to digital High Z (DM[2:0] = 010b), then

the pin is selected for global input (PIN drives to the Global Input Bus). In non-High Z modes, the block is selected for global output (the Global Output Bus drives to PIN), bypassing the data register value (assuming I2C Enable = 0).

If the PRTxGS register is written to zero, the global in/out function is disabled for the pin and the pin reflects the value of PRT_DR.

For additional information, refer to the [PRTxGS register on page 151](#).

6.2.4 PRTxDMx Registers

Address	Name	Bit 7	Bit 6	Bit 5	Bit 4	Bit 3	Bit 2	Bit 1	Bit 0	Access
0,xxh	PRTxDM2	Drive Mode 2[7:0]								RW : FF
1,xxh	PRTxDM0	Drive Mode 0[7:0]								RW : 00
1,xxh	PRTxDM1	Drive Mode 1[7:0]								RW : FF

LEGEND

xx An "x" after the comma in the address field indicates that there are multiple instances of the register. For an expanded address listing of these registers, refer to the "Core Register Summary" on page 60.

The Port Drive Mode Bit Registers (PRTxDMx) are used to specify the Drive mode for GPIO pins.

Note The CY8C21x34, CY7C603xx, and CYWUSB6953 have a 4-bit wide Port 3.

Bits 7 to 0: Drive Mode x[7:0]. In the PRTxDMx registers there are eight possible drive modes for each port pin. Three mode bits are required to select one of these modes, and these three bits are spread into three different registers (PRTxDM0, PRTxDM1, and PRTxDM2). The bit position of the effected port pin (for example, Pin[2] in Port 0) is the same as the bit position of each of the three drive mode register bits that control the Drive mode for that pin (for example, bit[2] in PRT0DM0, bit[2] in PRT0DM1, and bit[2] in PRT0DM2). The three bits from the three registers are treated as a group. These are referred to as DM2, DM1, and DM0, or together as DM[2:0]. Drive modes are shown in Table 6-1.

For analog IO, the Drive mode should be set to one of the High Z modes, either 010b or 110b. The 110b mode has the advantage that the block's digital input buffer is disabled, so no **crowbar** current flows even when the analog input is not close to either power rail. When digital inputs are needed on the same pin as analog inputs, the 010b Drive mode should be used. If the 110b Drive mode is used, the pin will always be read as a zero by the CPU and the pin will not be able to generate a useful interrupt. (It is not strictly required that a High Z mode be selected for analog operation.)

For global input modes, the Drive mode must be set to 010b.

Table 6-1. Pin Drive Modes

Drive Modes			Pin State	Description
DM2	DM1	DM0		
0	0	0	Resistive pull down	Strong high, resistive low
0	0	1	Strong drive	Strong high, strong low
0	1	0	High impedance	High Z high and low, digital input enabled
0	1	1	Resistive pull up	Resistive high, strong low
1	0	0	Open drain high	Slow strong high, High Z low
1	0	1	Slow strong drive	Slow strong high, slow strong low
1	1	0	High impedance, analog (reset state)	High Z high and low, digital input disabled (for zero power) (reset state)
1	1	1	Open drain low	Slow strong low, High Z high

The GPIO provides a default Drive mode of high impedance, analog (High Z). This is achieved by forcing the reset state of all PRTxDM1 and PRTxDM2 registers to FFh.

The resistive drive modes place a **resistance** in series with the output, for low outputs (mode 000b) or high outputs (mode 011b). Strong Drive mode 001b gives the fastest edges at high DC drive strength. Mode 101b gives the same drive strength but with slower edges. The open-drain modes (100b and 111b) also use the slower edge rate drive. These modes enable open-drain functions such as I2C mode 111b (although the slow edge rate is not slow enough to meet the I2C fast mode specification).

For additional information, refer to the PRTxDM2 register on page 152, the PRTxDM0 register on page 253, and the PRTxDM1 register on page 254.

6.2.5 PRTxICx Registers

Address	Name	Bit 7	Bit 6	Bit 5	Bit 4	Bit 3	Bit 2	Bit 1	Bit 0	Access
1,xxh	PRTxIC0	Interrupt Control 0[7:0]								RW : 00
1,xxh	PRTxIC1	Interrupt Control 1[7:0]								RW : 00

LEGEND

xx An "x" after the comma in the address field indicates that there are multiple instances of the register. For an expanded address listing of these registers, refer to the "Core Register Summary" on page 60.

The Port Interrupt Control Registers (PRTxIC1 and PRTxIC0) are used to specify the Interrupt mode for GPIO pins.

Note The CY8C21x34, CY7C603xx, and CYWUSB6953 have a 4-bit wide Port 3.

Bits 7 to 0: Interrupt Control x[7:0]. In the PRTxICx registers, the Interrupt mode for the pin is determined by bits in these two registers. These are referred to as IC1 and IC0, or together as IC[1:0].

There are four possible interrupt modes for each port pin. Two mode bits are required to select one of these modes and these two bits are spread into two different registers (PRTxIC0 and PRTxIC1). The bit position of the effected port pin (for example, Pin[2] in Port 0) is the same as the bit position of each of the interrupt control register bits that control the Interrupt mode for that pin (for example, bit[2] in PRT0IC0 and bit[2] in PRT0IC1). The two bits from the two registers are treated as a group.

The Interrupt mode must be set to one of the non-zero modes listed in Table 6-2, in order to get an interrupt from the pin.

The GPIO Interrupt mode “disabled” (00b) disables interrupts from the pin, even if the GPIO’s bit interrupt enable is on (from the PRTxE register).

Interrupt mode 01b means that the block will assert the interrupt line (INTO) when the pin voltage is low, providing the block’s bit interrupt enable line is set (high).

Interrupt mode 10b means that the block will assert the interrupt line (INTO) when the pin voltage is high, providing the block’s bit interrupt enable line is set (high).

Interrupt mode 11b means that the block will assert the interrupt line (INTO) when the pin voltage is the opposite of the last state read from the pin, providing the block’s bit interrupt enable line is set high. This mode switches between low mode and high mode, depending on the last value that was read from the port during reads of the data register (PRTxDR). If the last value read from the GPIO was ‘0’, the GPIO will subsequently be in Interrupt High mode. If the last value read from the GPIO was ‘1’, the GPIO will then be in Interrupt Low mode.

Table 6-2. GPIO Interrupt Modes

Interrupt Modes		Description
IC1	IC0	
0	0	Bit interrupt disabled, INTO de-asserted
0	1	Assert INTO when PIN = low
1	0	Assert INTO when PIN = high
1	1	Assert INTO when PIN = change from last read

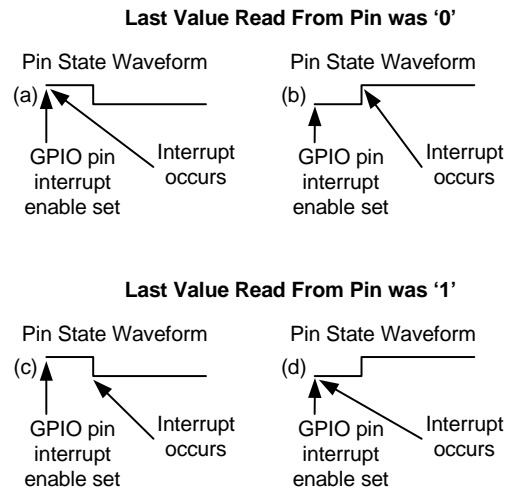

Figure 6-3. GPIO Interrupt Mode 11b

Figure 6-3 assumes that the GIE is set, GPIO interrupt mask is set, and that the GPIO Interrupt mode has been set to 11b. The Change Interrupt mode is different from the other modes, in that it relies on the value of the GPIO’s read latch to determine if the pin state has changed. Therefore, the port that contains the GPIO in question must be read during every interrupt service routine. If the port is not read, the Interrupt mode will act as if it is in high mode when the latch value is ‘0’ and low mode when the latch value is ‘1’.

For additional information, refer to the PRTxIC0 register on page 255 and the PRTxIC1 register on page 256.

7. Analog Output Drivers



This chapter presents the Analog Output Drivers and their associated register. The analog output drivers provide a means for driving analog signals off the PSoC device. For a quick reference of all PSoC registers in address order, refer to the [Register Details chapter on page 147](#). For information on the analog system, refer to the “[Analog System](#)” on page 371.

7.1 Architectural Description

Depending on which PSoC device you have (see [Table 7-1](#)), the PSoC device has up to four analog drivers used to output analog values on port pins. Note that there are no analog output drivers for the CY8C21x34, CY8C21x23, CY7C603xx, and CYWUSB6953 PSoC devices.

Each of these drivers is a resource available to all the **analog blocks** in a particular analog column. Therefore, the number of analog output drivers will match the number of analog columns in a device. The user must select no more than one analog block per column to drive a signal on its analog output bus (ABUS), to serve as the input to the analog driver for that column. The output from the analog output driver for each column can be enabled and disabled using the Analog Output Driver register ABF_CR0. If the analog output driver is enabled, then it must have an analog block driving the ABUS for that column. Otherwise, the analog output driver can enter a high current consumption mode.

Table 7-1. PSoC Analog Output Drivers

Port Pin	CY8C29x66 CY8CPLC20 CY8CLED16P01	CY8C27x43	CY8C24x94	CY8C24x23	CY8C24x23A	CY8C22x13	CY7C64215	CY8CNP1xx
P0[5]	✓	✓	✓	✓	✓	✓	✓	✓
P0[4]	✓	✓						✓
P0[3]	✓	✓	✓	✓	✓		✓	✓
P0[2]	✓	✓						✓

[Figure 7-1](#) illustrates the drivers and their relationship within the analog array. For a detailed drawing of the analog output drivers in relation to the analog system, refer to the [Analog Input Configuration chapter on page 403](#).

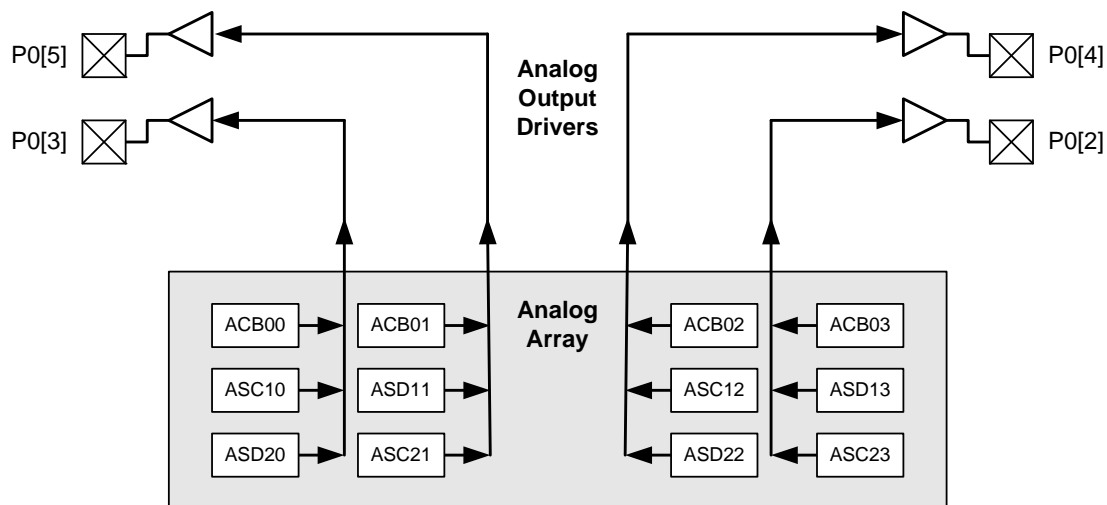

Figure 7-1. Analog Output Drivers

7.2 Register Definitions

The following register is associated with the Analog Output Drivers. The register description has an associated register table showing the bit structure of the register. The bits that are grayed out in the table below are reserved bits and are not detailed in the register description that follows. Reserved bits should always be written with a value of '0'. Depending on the number of analog columns your PSoC device has (see the Cols. column in the register table below), some bits may be reserved (refer to the table titled "PSoC Device Characteristics" on page 22).

7.2.1 ABF_CR0 Register

Addr.	Name	Cols.	Bit 7	Bit 6	Bit 5	Bit 4	Bit 3	Bit 2	Bit 1	Bit 0	Access
1,62h	ABF_CR0	4	ACol1Mux	ACol2Mux	ABUF1EN	ABUF2EN	ABUF0EN	ABUF3EN	Bypass	PWR	RW : 00
		2	ACol1Mux		ABUF1EN		ABUF0EN		Bypass	PWR	
		1	ACol1Mux		ABUF1EN				Bypass	PWR	

The Analog Output Buffer Control Register 0 (ABF_CR0) controls analog input muxes from Port 0 and the output buffer amplifiers that drive column outputs to device pins.

For more information on bits 7 and 6, see the [Analog Input Configuration chapter on page 403](#).

Bit 7: ACol1MUX. A mux selects the output of column 0 input mux or column 1 input mux. When set, this bit sets the column 1 input to column 0 input mux output.

Bit 6: ACol2MUX. A mux selects the output of column 2 input mux or column 3 input mux. When set, this bit sets the column 2 input to column 3 input mux output.

Bits 5 to 2: ABUFxEN. These bits enable or disable the column output amplifiers.

Bit 1: Bypass. Bypass mode connects the analog output driver input directly to the output. When this bit is set, all analog output drivers will be in bypass mode. This is a high impedance connection used primarily for measurement and calibration of internal references. Use of this feature is not recommended for customer designs.

Bit 0: PWR. This bit is used to set the power level of the analog output drivers. When this bit is set, all of the analog output drivers will be in a High Power mode.

For additional information, refer to the [ABF_CR0 register on page 267](#).

8. Internal Main Oscillator (IMO)



This chapter presents the Internal Main Oscillator (IMO) and its associated registers. The IMO produces clock signals of 24 MHz and 48 MHz. For a complete table of the IMO registers, refer to the “Summary Table of the Core Registers” on page 60. For a quick reference of all PSoC registers in address order, refer to the Register Details chapter on page 147.

8.1 Architectural Description

The Internal Main Oscillator (IMO) outputs two clocks: a SYSCLK, which can be the internal 24 MHz clock or an external clock, and a SYSCLKX2 that is always twice the SYSCLK frequency. In the absence of a high-precision input source from the 32.768 kHz **crystal oscillator**, the accuracy of the internal 24/48 MHz clocks will be +/-2.5% over temperature variation and two voltage ranges (3.3V ± 0.3V and 5.0V ± 0.25V). No external components are required to achieve this level of accuracy.

There is an option to phase lock this oscillator to the External Crystal Oscillator (ECO). The choice of crystal and its inherent accuracy will determine the overall accuracy of the oscillator. The ECO must be stable prior to locking the frequency of the IMO to this reference source. Note that this ECO option is not available on the CY8C21x34, CY8C21x23, CY7C603xx, or CYWUSB6953 PSoC devices.

The IMO can be disabled when using an external clocking source. Also, the **frequency** doubler circuit, which produces SYSCLKX2, can be disabled to save power. Note that when using an external clock, if SYSCLKX2 is needed, then the IMO cannot be disabled. Registers for controlling these operations are found in the [Digital Clocks chapter on page 459](#).

On some PSoC devices (see [Table 8-1](#) showing check mark confirmation), lower frequency SYSCLK settings are available by setting the slow IMO (SLIMO) bit in the CPU_SCR1 register. With this bit set and the corresponding factory trim value applied to the IMO_TR register, SYSCLK can be lowered to 6 MHz. This offers lower device power consumption for systems that can operate with the reduced system clock. Slow IMO mode is discussed further in the “[Application Description](#)” on page 113.

8.2 PSoC Device Distinctions

In the CY8C27x43, CY8C24x23, CY8C22x13, CY7C603xx, and CYWUSB6953 PSoC devices, the Slow IMO mode (bit 4 in the CPU_SCR1 register on page 251) is reserved. In the table below, the slow IMO option is available for the following checked PSoC devices.

Table 8-1. Slow IMO (SLIMO) Option Availability

PSoC Device	Slow IMO Option
CY8C29x66 CY8CPLC20 CY8CLED16P01	✓
CY8C27x43	
CY8C24x94	
CY8C24x23	
CY8C24x23A	✓
CY8C22x13	
CY8C21x34	✓
CY8C21x23	✓
CY7C64215	
CY7C603xx	✓
CYWUSB6953	✓
CY8CNP1xx	✓

8.3 Application Description

To save power, the IMO frequency can be reduced from 24 MHz to 6 MHz or 12 MHz using the SLIMO bit in the CPU_SCR1 register, in conjunction with the Trim values in the IMO_TR register. How to do this is described in the sections that follow. Note that the CY8C27x43, CY8C24x23, CY8C22x13, CY7C603xx, CY8CNP1xx, and CYWUSB6953 devices do not have this functionality.

8.3.1 Trimming the IMO

An 8-bit register (IMO_TR) is used to trim the IMO. Bit 0 is the LSB and bit 7 is the MSB. The trim step size is approximately 80 kHz.

A factory trim setting is loaded into the IMO_TR register at boot time for $5V \pm 0.25V$ operation, except for the CY7C603xx, which is $3.3V \pm 0.25V$. For operation in the voltage ranges of $3.3V \pm 0.3V$ and $2.7V \pm 0.3V$, user code must modify the contents of this register with values stored in Flash bank 0 as shown in [Table 3-11 on page 77](#). This is done with a Table Read command to the Supervisory ROM.

8.3.2 Engaging Slow IMO (SLIMO)

Setting the CPU_SCR1 register bit 4 high engages the SLIMO feature. The trim values for SLIMO are stored in Flash bank 0 as shown [Table 3-11 on page 77](#) for the following voltage and frequency combinations. An SROM function is performed to set the different IMO frequencies based on the CPU_SCR1 register.

Table 8-2. IMO and SLIMO Voltage Frequency

Voltage	Normal IMO Frequency	Slow IMO Frequency
$5.0V \pm 0.25V$	24 MHz	6 MHz
$3.3V \pm 0.3V$	24 MHz	6 MHz
$2.7V \pm 0.3V$	12 MHz	6 MHz

8.4 Register Definitions

The following registers are associated with the Internal Main Oscillator (IMO). The register descriptions have an associated register table showing the bit structure for that register. The bits in the tables that are grayed out are reserved bits and are not detailed in the register descriptions that follow. Reserved bits should always be written with a value of '0'. For a complete table showing all oscillator registers, refer to the “Summary Table of the Core Registers” on page 60.

8.4.1 CPU_SCR1 Register

Address	Name	Bit 7	Bit 6	Bit 5	Bit 4	Bit 3	Bit 2	Bit 1	Bit 0	Access
x,FEh	CPU_SCR1	IRESS			SLIMO	ECO EXW *	ECO EX *		IRAMDIS	# : 00

LEGEND

x An “x” before the comma in the address field indicates that this register can be read or written to no matter what bank is used.

Access is bit specific. Refer to the [Register Details chapter on page 147](#) for additional information.

* Bits 3 and 2 (ECO EXW and ECO EX, respectively) cannot be used by the CY8C27x43 for silicon revision A, and by the CY8C24x23 and CY8C22x13 PSoC devices.

The System Status and Control Register 1 (CPU_SCR1) is used to convey the status and control of events related to internal resets and watchdog reset.

Bit 7: IRESS. The Internal Reset Status bit is a read only bit that may be used to determine if the booting process occurred more than once.

When this bit is set, it indicates that the SROM SWBootReset code was executed more than once. If this bit is not set, the SWBootReset was executed only once. In either case, the SWBootReset code will not allow execution from code stored in Flash until the M8C Core is in a safe operating mode with respect to supply voltage and Flash operation. There is no need for concern when this bit is set. It is provided for systems which may be sensitive to boot time, so that they can determine if the normal one-pass boot time was exceeded. For more information on the SWBootReset code see the [Supervisory ROM \(SROM\) chapter on page 73](#).

Bit 4: SLIMO. When set, the Slow IMO bit allows the active power dissipation of the PSoC device to be reduced by slowing down the IMO from 24 MHz to 6 MHz. The IMO trim value must also be changed when SLIMO is set (see “[Engaging Slow IMO \(SLIMO\)](#)” on page 114). When not in external clocking mode, the IMO is the source for SYSCLK; therefore, when the speed of the IMO changes, so will SYSCLK.

Bit 3: ECO EXW. The ECO Exists Written bit is used as a status bit to indicate that the ECO EX bit has been previously written to. It is read only. When this bit is a ‘1’, this indicates that the CPU_SCR1 register has been written to and is now locked. When this bit is a ‘0’, the register has not been written to since the last reset event. Note that this bit cannot be used by the CY8C27x43 for silicon revision A, and by the CY8C24x23 and CY8C22x13 PSoC devices.

Bit 2: ECO EX. The ECO Exists bit serves as a flag to the hardware, to indicate that an external crystal **oscillator** exists in the system. Just after boot, it may be written *only once* to a value of ‘1’ (crystal exists) or ‘0’ (crystal does not exist). If the bit is ‘0’, a switch-over to the ECO is locked out by hardware. If the bit is ‘1’, hardware allows the firmware to freely switch between the ECO and ILO. It should be written as early as possible after a **Power On Reset (POR)** or **External Reset (XRES)** event, where it is assumed that program execution integrity is high. Note that this bit cannot be used by the CY8C27x43 for silicon revision A, and by the CY8C24x23 and CY8C22x13 PSoC devices.

Bit 0: IRAMDIS. The Initialize RAM Disable bit is a control bit that is readable and writeable. The **default value** for this bit is ‘0’, which indicates that the maximum amount of SRAM should be initialized on watchdog reset to a value of 00h. When the bit is ‘1’, the minimum amount of SRAM is initialized after a watchdog reset. For more information on this bit, see the “[SROM Function Descriptions](#)” on page 74.

For additional information, refer to the [CPU_SCR1 register on page 251](#).

8.4.2 OSC_CR2 Register

Address	Name	Bit 7	Bit 6	Bit 5	Bit 4	Bit 3	Bit 2	Bit 1	Bit 0	Access
1,E2h	OSC_CR2	PLLGAIN					EXTCLKEN	IMODIS	SYSCCLKX2DIS	RW : 00

The Oscillator Control Register 2 (OSC_CR2) is used to configure various features of internal clock sources and clock nets.

Bit 7: PLLGAIN. This is the only bit in the OSC_CR2 register that directly influences the PLL. When set, this bit keeps the PLL in Low Gain mode. If this bit is held low, the lock time is less than 10 ms. If this bit is held high, the lock time is on the order of 50 ms. After lock is achieved, it is recommended that this bit be forced high to decrease the jitter on the output. If longer lock time is tolerable, the PLLGAIN bit can be held high all the time.

Bit 2: EXTCLKEN. When the EXTCLKEN bit is set, the external clock becomes the source for the internal clock tree, SYSCCLK, which drives most PSoC device clocking functions. All external and internal signals, including the 32 kHz clock, whether derived from the Internal Low Speed

Oscillator (ILO) or the crystal oscillator, are synchronized to this clock source. If an external clock is enabled, PLL mode should be off. The external clock input is located on port P1[4]. When using this input, the pin drive mode should be set to High Z (not High Z analog).

Bit 1: IMODIS. When IMODIS is set, the Internal Main Oscillator (IMO) is disabled. If the doubler is enabled (SYSCCLKX2DIS=0), the IMO is forced on.

Bit 0: SYSCCLKX2DIS. When SYSCCLKX2DIS is set, the IMO's doubler is disabled. This will result in a reduction of overall device power, on the order of 1 mA. It is advised that any application that does not require this doubled clock should have it turned off.

For additional information, refer to the [OSC_CR2 register on page 293](#).

8.4.3 IMO_TR Register

Address	Name	Bit 7	Bit 6	Bit 5	Bit 4	Bit 3	Bit 2	Bit 1	Bit 0	Access
1,E8h	IMO_TR	Trim[7:0]								W : 00

The Internal Main Oscillator Trim Register (IMO_TR) is used to manually center the oscillator's output to a target frequency.

The PSoC device specific value for 5V operation is loaded into the Internal Main Oscillator Trim register (IMO_TR) at boot time. The Internal Main Oscillator will operate within specified tolerance over a voltage range of 4.75V to 5.25V, with no modification of this register. If the PSoC device is operated at a lower voltage, user code must modify the contents of this register. For operation in the voltage range of 3.3V +/- .3V, this is accomplished with a Table Read command to the Supervisory ROM, which will supply a trim

value for operation in this range. For operation between these voltage ranges, user code can interpolate the best value using both available factory trim values.

It is strongly recommended that the user not alter the register value, unless Slow IMO mode is used.

Bits 7 to 0: Trim[7:0]. These bits are used to trim the Internal Main Oscillator. A larger value in this register will increase the speed of the oscillator.

For additional information, refer to the [IMO_TR register on page 298](#).

9. Internal Low Speed Oscillator



This chapter briefly explains the Internal Low Speed Oscillator (ILO) and its associated register. The Internal Low Speed Oscillator produces a 32 kHz clock. For a quick reference of all PSoC registers in address order, refer to the [Register Details chapter on page 147](#).

9.1 Architectural Description

The Internal Low Speed Oscillator (ILO) is an oscillator with a nominal frequency of 32 kHz. It is used to generate Sleep Wake-up interrupts and watchdog resets. This oscillator can also be used as a clocking source for the digital PSoC blocks.

The oscillator operates in three modes: normal power, low power, and off. The Normal Power mode consumes more current to produce a more accurate frequency. The Low Power mode is always used when the part is in a power down (sleep) state.

9.2 Register Definitions

The following register is associated with the Internal Low Speed Oscillator (ILO). The register description has an associated register table showing the bit structure. The bits in the table that are grayed out are reserved bits and are not detailed in the register description that follows. Note that reserved bits should always be written with a value of '0'.

9.2.1 ILO_TR Register

Address	Name	Bit 7	Bit 6	Bit 5	Bit 4	Bit 3	Bit 2	Bit 1	Bit 0	Access
1,E9h	ILO_TR			Bias Trim[1:0]		Freq Trim[3:0]				W : 00

The Internal Low Speed Oscillator Trim Register (ILO_TR) sets the adjustment for the internal low speed oscillator.

The device specific value, placed in the trim bits of this register at boot time, is based on factory testing. ***It is strongly recommended that you do not alter the values in the register.***

Bits 5 and 4: Bias Trim[1:0]. These two bits are used to set the bias current in the PTAT Current Source. Bit 5 gets inverted, so that a medium bias is selected when both bits are '0'. The **bias current** is set according to [Table 9-1](#).

Table 9-1. Bias Current in PTAT

Bias Current	Bias Trim [1:0]
Medium Bias	00b
Maximum Bias	01b
Minimum Bias	10b
Reserved	11b

Bits 3 to 0: Freq Trim[3:0]. These four bits are used to trim the frequency. Bit 0 is the LSb and bit 3 is the MSb. Bit 3 gets inverted inside the register.

For additional information, refer to the [ILO_TR register on page 299](#).

10. External Crystal Oscillator (ECO)



This chapter briefly explains the External Crystal Oscillator (ECO) and its associated registers. The 32.768 kHz external crystal oscillator circuit allows the user to replace the internal low speed oscillator with a more precise time source at low cost and low power. For a complete table of the External Crystal Oscillator registers, refer to the “[Summary Table of the Core Registers](#)” on page 60. For a quick reference of all PSoC registers in address order, refer to the [Register Details](#) chapter on page 147.

10.1 Architectural Description

The External Crystal Oscillator (ECO) circuit uses an inexpensive watch crystal and two small value capacitors as external components, with all other components being on the PSoC device. The crystal oscillator may be configured to provide a reference to the Internal Main Oscillator (IMO) in PLL mode, for generating a 24 MHz system clock.

The following table lists the families that support ECO.

Table 10-1. ECO Supported Families

PSoC Device Family	ECO Support
CY8CPLC20	Yes
CY8CLED16P01	Yes
CY8C29x66	Yes
CY8C27x43	Yes
CY8C24x94	No
CY8C24x23/A	Yes
CY8C22x13	Yes
CY8C21x34	No
CY8C21x23	No
CY7C64215	No
CY7C603xx	No
CY8CNP1xx	Yes
CYWUSB6953	No

The XTALIn and XTALOut pins support connection of a 32.768 kHz watch crystal. To use the external crystal, bit 7 of the Oscillator Control 0 register (OSC_CR0) must be set (the default is off). The only external components needed are the crystal and the two capacitors that connect to Vdd. Note that transitions between the internal and external oscillator domains may produce glitches on the clock bus.

During the process of activating the ECO, there must be a hold-off period before using it as the 32.768 kHz source. This hold-off period is partially implemented in hardware using the sleep timer. Firmware must set up a sleep period of one second (maximum ECO **settling time**), and then

enable the ECO in the OSC_CR0 register. At the one second time-out (the sleep interrupt), the switch is made by hardware to the ECO. If the ECO is subsequently deactivated, the Internal Low Speed Oscillator (ILO) will again be activated and the switch is made back to the ILO immediately.

The ECO Exists bit (ECO EX, bit 2 in the CPU_SCR1 register) is used to control whether the switch-over is allowed or locked. This is a write once bit. It is written early in code execution after a Power On Reset (POR) or external reset (XRES) event. A ‘1’ in this bit indicates to the hardware that a crystal exists in the system, and firmware is allowed to switch back and forth between ECO and ILO operation. If the bit is ‘0’, switch-over to the ECO is locked out. The ECO Exists Written bit (ECO EXW, bit 3 in the CPU_SCR1 register) is read only and is set on the first write to this register. When this bit is ‘1’, it indicates that the state of ECO EX is locked. This is illustrated in [Figure 10-1](#).

Note Bits 3 and 2 (ECO EXW and ECO EX, respectively) in the CPU_SCR1 register cannot be used by the CY8C27x43

External Crystal Oscillator (ECO)

for silicon revision A, and by the CY8C24x23 and CY8C22x13 PSoC devices.

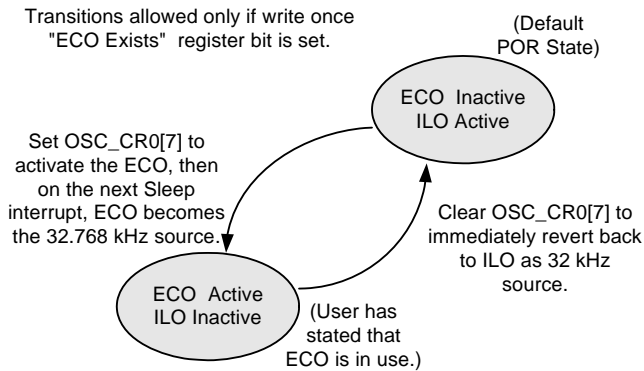

Figure 10-1. State Transition Between ECO and ILO Operation

The firmware steps involved in switching between the Internal Low Speed Oscillator (ILO) to the 32.768 kHz External Crystal Oscillator (ECO) are as follows.

1. At reset, the PSoC device begins operation, using the ILO.
2. Set the ECO EX bit to allow crystal operation.
3. Select a sleep interval of one second, using bits[4:3] in the Oscillator Control 0 register (OSC_CR0), as the oscillator stabilization interval.
4. Enable the ECO by setting bit [7] in Oscillator Control 0 register (OSC_CR0) to '1'.
5. The ECO becomes the selected source at the end of the one-second interval on the edge created by the Sleep Interrupt logic. The one-second interval gives the oscillator time to stabilize before it becomes the active source. The sleep interrupt need not be enabled for the switch-over to occur. Reset the sleep timer (if this does not interfere with any ongoing real-time clock operation), to guarantee the interval length. Note that the ILO continues to run until the oscillator is automatically switched over by the sleep timer interrupt.
6. It is strongly advised to wait the one-second stabilization period prior to engaging the PLL mode to lock the IMO frequency to the ECO frequency.

Note 1 The ILO switches back instantaneously by writing the 32 kHz Select Control bit to '0'.

Note 2 If the proper settings are selected in PSoC Designer, the above steps are automatically done in *boot.asm*.

Note 3 Transitions between oscillator domains may produce glitches on the 32 kHz clock bus. Functions that

require accuracy on the 32 kHz clock should be enabled after the transition in oscillator domains.

10.1.1 ECO External Components

The external component connections and selections of the External Crystal Oscillator are illustrated in Figure 10-2.

- Crystal – 32.768 kHz watch crystal such as Epson C-002RX.
- Capacitors – C1, C2 use NPO ceramic caps.

Use the equation below if you do not employ PLL mode.

$$C1 = C2 = 25 \text{ pF} - (\text{Package Capacitance}) - (\text{Board Parasitic Capacitance})$$

An error of 1 pF in C1 and C2 gives about a 3 ppm error in frequency.

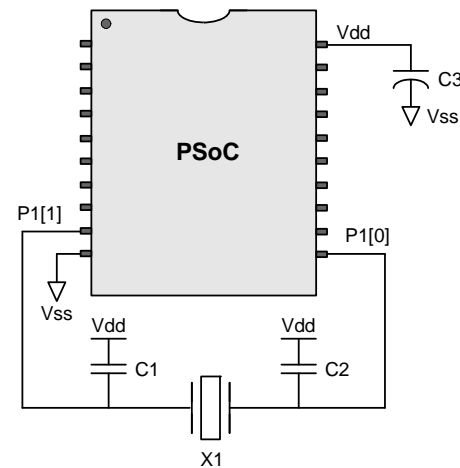

Figure 10-2. 20-Pin PSoC Example of the ECO External Connections

Refer to the PSoC devices' data sheet, in the packaging chapter, for typical package capacitances on crystal pins.

10.2 PSoC Device Distinctions

Bits 3 and 2 (ECO EXW and ECO EX, respectively) in the CPU_SCR1 register cannot be used by the CY8C27x43 for silicon revision A, and by the CY8C24x23 and CY8C22x13 PSoC devices. Bits 6 and 7 of the OSC_CR0 register are not available for the CY8C24x94, CY8C21x34, CY8C21x23, CY7C64215 and CY7C603xx families. This is because of their inability to have an ECO.

10.3 Register Definitions

The following registers are associated with the External Crystal Oscillator and are listed in address order. Each register description has an associated register table showing the bit structure for that register. The bits that are grayed out in the tables below are reserved bits and are not detailed in the register descriptions. Note that reserved bits should always be written with a value of '0'. For a complete table of external crystal oscillator registers, refer to the “[Summary Table of the Core Registers](#)” on page 60.

10.3.1 CPU_SCR1 Register

Address	Name	Bit 7	Bit 6	Bit 5	Bit 4	Bit 3	Bit 2	Bit 1	Bit 0	Access
x,FEh	CPU_SCR1	IRESS			SLIMO	ECO EXW *	ECO EX *		IRAMDIS	# : 00

LEGEND

x An “x” before the comma in the address field indicates that this register can be read or written to no matter what bank is used.

Access is bit specific. Refer to the [Register Details chapter on page 147](#) for additional information.

* Bits 3 and 2 (ECO EXW and ECO EX, respectively) cannot be used by the CY8C27x43 for silicon revision A, and by the CY8C24x23 and CY8C22x13 PSoC devices.

The System Status and Control Register 1 (CPU_SCR1) is used to convey the status and control of events related to internal resets and watchdog reset.

Bit 7: IRESS. The Internal Reset Status bit is a read only bit that may be used to determine if the booting process occurred more than once.

When this bit is set, it indicates that the SROM SWBootReset code was executed more than once. If this bit is not set, the SWBootReset was executed only once. In either case, the SWBootReset code will not allow execution from code stored in Flash until the M8C Core is in a safe operating mode with respect to supply voltage and Flash operation. There is no need for concern when this bit is set. It is provided for systems which may be sensitive to boot time, so that they can determine if the normal one-pass boot time was exceeded. For more information on the SWBootReset code see the [Supervisory ROM \(SROM\) chapter on page 73](#).

Bit 4: SLIMO. When set, the Slow IMO bit allows the active power dissipation of the PSoC device to be reduced by slowing down the IMO from 24 MHz to 6 MHz. The IMO trim value must also be changed when SLIMO is set (see “[Engaging Slow IMO \(SLIMO\)](#)” on page 114). When not in external clocking mode, the IMO is the source for SYSCLK; therefore, when the speed of the IMO changes, so will SYSCLK.

Bit 3: ECO EXW. The ECO Exists Written bit is used as a status bit to indicate that the ECO EX bit has been previously written to. It is read only. When this bit is a '1', this indicates that the CPU_SCR1 register has been written to and is now locked. When this bit is a '0', the register has not been written to since the last reset event. Note that this bit cannot be used by the CY8C27x43 for silicon revision A, and by the CY8C24x23 and CY8C22x13 PSoC devices.

Bit 2: ECO EX. The ECO Exists bit serves as a flag to the hardware, to indicate that an external crystal *oscillator* exists in the system. Just after boot, it may be written *only once* to a value of '1' (crystal exists) or '0' (crystal does not exist). If the bit is '0', a switch-over to the ECO is locked out by hardware. If the bit is '1', hardware allows the firmware to freely switch between the ECO and ILO. It should be written as early as possible after a **Power On Reset (POR)** or **External Reset (XRES)** event, where it is assumed that program execution integrity is high. Note that this bit cannot be used by the CY8C27x43 for silicon revision A, and by the CY8C24x23 and CY8C22x13 PSoC devices.

Bit 0: IRAMDIS. The Initialize RAM Disable bit is a control bit that is readable and writeable. The **default value** for this bit is '0', which indicates that the maximum amount of SRAM should be initialized on watchdog reset to a value of 00h. When the bit is '1', the minimum amount of SRAM is initialized after a watchdog reset. For more information on this bit, see the “[SROM Function Descriptions](#)” on page 74.

For additional information, refer to the [CPU_SCR1 register on page 251](#).

10.3.2 OSC_CR0 Register

Address	Name	Bit 7	Bit 6	Bit 5	Bit 4	Bit 3	Bit 2	Bit 1	Bit 0	Access
1,E0h	OSC_CR0	32k Select	PLL Mode	No Buzz	Sleep[1:0]		CPU Speed[2:0]			RW : 00

The Oscillator Control Register 0 (OSC_CR0) is used to configure various features of internal clock sources and clock nets.

Bit 7: 32k Select. By default, the 32 kHz clock source is the Internal Low Speed Oscillator (ILO). Optionally, the 32.768 kHz External Crystal Oscillator (ECO) may be selected.

Bit 6: PLL Mode. This is the only bit in the OSC_CR0 register that directly influences the Phase Locked Loop (PLL). When set, this bit enables the PLL. The EXTCLKEN bit in the OSC_CR2 register should be set low during PLL operation. For information on the PLL, refer to the [Phase-Locked Loop \(PLL\) chapter on page 125](#).

Bit 5: No Buzz. Normally, when the Sleep bit is set in the CPU_SCR register, all PSoC device systems are powered down, including the bandgap reference. However, to facilitate the detection of **POR** and **LVD** events at a rate higher than the sleep interval, the bandgap circuit is powered up periodically for about 60 μs at the Sleep System Duty Cycle (set in ECO_TR), which is independent of the sleep interval and typically higher. When the No Buzz bit is set, the Sleep System Duty Cycle value is overridden and the bandgap circuit is forced to be on during sleep. This results in a faster response to an LVD or POR event (continuous detection as opposed to periodic detection), at the expense of higher average sleep current.

Bits 4 and 3: Sleep[1:0]. The available sleep interval selections are shown in [Table 10-2](#). It must be remembered that when the ILO is the selected 32 kHz clock source, sleep intervals are approximate.

Table 10-2. Sleep Interval Selections

Sleep Interval OSC_CR[4:3]	Sleep Timer Clocks	Sleep Period (nominal)	Watchdog Period (nominal)
00b (default)	64	1.95 ms	6 ms
01b	512	15.6 ms	47 ms
10b	4,096	125 ms	375 ms
11b	32,768	1 sec	3 sec

Bits 2 to 0: CPU Speed[2:0]. The PSoC M8C may operate over a range of CPU clock speeds (see [Table 10-3](#)), allowing the M8C's performance and power requirements to be tailored to the application.

The reset value for the CPU Speed bits is zero; therefore, the default CPU speed is one-eighth of the clock source. The Internal Main Oscillator (IMO) is the default clock source for the CPU speed circuit; therefore, the default CPU speed is 3 MHz.

The CPU frequency is changed with a write to the OSC_CR0 register. There are eight frequencies generated from a power-of-2 divide circuit, which are selected by a 3-bit code. At any given time, the CPU 8-to-1 clock mux is selecting one of the available frequencies, which is resynchronized to the 24 MHz master clock at the output.

Regardless of the CPU Speed bit's setting, if the actual CPU speed is greater than 12 MHz, the 24 MHz operating requirements apply. An example of this scenario is a device that is configured to use an external clock, which is supplying a frequency of 20 MHz. If the CPU speed register's value is 0b011, the CPU clock will be 20 MHz. Therefore, the supply voltage requirements for the device are the same as if the part was operating at 24 MHz off of the IMO. The operating voltage requirements are not relaxed until the CPU speed is at 12 MHz or less.

Table 10-3. OSC_CR0[2:0] Bits: CPU Speed

Bits	Internal Main Oscillator	External Clock
000b	3 MHz	EXTCLK/ 8
001b	6 MHz	EXTCLK/ 4
010b	12 MHz	EXTCLK/ 2
011b	24 MHz	EXTCLK/ 1
100b	1.5 MHz	EXTCLK/ 16
101b	750 kHz	EXTCLK/ 32
110b	187.5 kHz	EXTCLK/ 128
111b	93.7 kHz	EXTCLK/ 256

For additional information, refer to the [OSC_CR0 register on page 291](#).

10.3.3 ECO_TR Register

Address	Name	Bit 7	Bit 6	Bit 5	Bit 4	Bit 3	Bit 2	Bit 1	Bit 0	Access
1,EBh	ECO_TR	PSSDC[1:0]								W : 00

The External Crystal Oscillator Trim Register (ECO_TR) sets the adjustment for the 32.768 kHz External Crystal Oscillator.

The device specific value placed in this register at boot time is based on factory testing. This register does not adjust the frequency of the external crystal oscillator.

It is strongly recommended that the user not alter the register value.

Bits 7 and 6: PSSDC[1:0]. These bits are used to set the sleep **duty cycle**. These bits should not be altered.

For additional information, refer to the [ECO_TR register](#) on page 301.

11. Phase-Locked Loop (PLL)



This chapter presents the Phase-Locked Loop (PLL) and its associated registers. For a complete table of the PLL registers, refer to the “[Summary Table of the Core Registers](#)” on page 60. For a quick reference of all PSoC registers in address order, refer to the [Register Details](#) chapter on page 147.

11.1 Architectural Description

A **Phase-Locked Loop (PLL)** function generates the system clock with crystal accuracy. It is designed to provide a 23.986 MHz oscillator, when utilized with an external 32.768 kHz crystal.

Although the PLL tracks crystal accuracy, it requires time to lock onto the reference frequency when first starting. The length of time depends on the PLLGAIN controlled by bit 7 of the OSC_CR2 register. If this bit is held low, the lock time is less than 10 ms. If this bit is held high, the lock time is on the order of 50 ms. After lock is achieved, it is recommended that this bit be forced high to decrease the *jitter* on the output. If longer lock time is tolerable, the PLLGAIN bit can be held high all the time.

After the 32.768 kHz External Crystal Oscillator (ECO) has been selected and enabled, the following procedure should be followed to enable the PLL and allow for proper frequency lock.

- Select a CPU frequency of 3 MHz or less.
- Enable the PLL.
- Wait between 10 and 50 ms, depending on bit 7 of the OSC_CR2 register.
- Set the CPU to a faster frequency, if desired. To do this, write the CPU Speed[2:0] bits in the OSC_CR0 register. The CPU frequency will immediately change when these bits are set.

If the proper settings are selected in *PSoC Designer*, the above steps are automatically done in *boot.asm*.

11.2 Register Definitions

The following registers are associated with the Phase Locked Loop (PLL) and are listed in address order. Each register description has an associated register table showing the bit structure for that register. The bits that are grayed out in the tables below are reserved bits and are not detailed in the register descriptions. Note that reserved bits should always be written with a value of '0'. For a complete table of the PLL registers, refer to the “[Summary Table of the Core Registers](#)” on page 60.

11.2.1 OSC_CR0 Register

Address	Name	Bit 7	Bit 6	Bit 5	Bit 4	Bit 3	Bit 2	Bit 1	Bit 0	Access
1_E0h	OSC_CR0	32k Select	PLL Mode	No Buzz	Sleep[1:0]		CPU Speed[2:0]			RW : 00

The Oscillator Control Register 0 (OSC_CR0) is used to configure various features of internal clock sources and clock nets.

Bit 7: 32k Select. By default, the 32 kHz clock source is the Internal Low Speed Oscillator (ILO). Optionally, the 32.768 kHz External Crystal Oscillator (ECO) may be selected.

Bit 6: PLL Mode. This is the only bit in the OSC_CR0 register that directly influences the Phase Locked Loop (PLL). When set, this bit enables the PLL. The EXTCLKEN bit in the OSC_CR2 register should be set low during PLL operation.

Bit 5: No Buzz. Normally, when the Sleep bit is set in the CPU_SCR register, all PSoC device systems are powered down, including the bandgap reference. However, to facilitate the detection of **POR** and **LVD** events at a rate higher than the sleep interval, the bandgap circuit is powered up periodically for about 60 μ s at the Sleep System Duty Cycle (set in ECO_TR), which is independent of the sleep interval and typically higher. When the No Buzz bit is set, the Sleep System Duty Cycle value is overridden and the bandgap circuit is forced to be on during sleep. This results in a faster response to an LVD or POR event (continuous detection as opposed to periodic detection), at the expense of slightly higher average sleep current.

Bits 4 and 3: Sleep[1:0]. The available sleep interval selections are shown in [Table 11-1](#). It must be remembered that when the ILO is the selected 32 kHz clock source, sleep intervals are approximate.

Table 11-1. Sleep Interval Selections

Sleep Interval OSC_CR[4:3]	Sleep Timer Clocks	Sleep Period (nominal)	Watchdog Period (nominal)
00b (default)	64	1.95 ms	6 ms
01b	512	15.6 ms	47 ms
10b	4096	125 ms	375 ms
11b	32,768	1 sec	3 sec

Bits 2 to 0: CPU Speed[2:0]. The PSoC M8C may operate over a range of CPU clock speeds (see [Table 11-2](#)), allowing the M8C's performance and power requirements to be tailored to the application.

The reset value for the CPU Speed bits is zero; therefore, the default CPU speed is one-eighth of the clock source.

The Internal Main Oscillator (IMO) is the default clock source for the CPU speed circuit; therefore, the default CPU speed is 3 MHz.

The CPU frequency is changed with a write to the OSC_CR0 register. There are eight frequencies generated from a power-of-2 divide circuit, which are selected by a 3-bit code. At any given time, the CPU 8-to-1 clock mux is selecting one of the available frequencies, which is resynchronized to the 24 MHz master clock at the output.

Regardless of the CPU Speed bit's setting, if the actual CPU speed is greater than 12 MHz, the 24 MHz operating requirements apply. An example of this scenario is a device that is configured to use an external clock, which is supplying a frequency of 20 MHz. If the CPU speed register's value is 0b011, the CPU clock will be 20 MHz. Therefore, the supply voltage requirements for the device are the same as if the part was operating at 24 MHz off of the IMO. The operating voltage requirements are not relaxed until the CPU speed is at 12 MHz or less.

Some devices support the slow IMO option, as discussed in the IMO chapter in the ["Architectural Description"](#) on [page 113](#). This offers an option to lower both system and CPU clock speed in order to save power.

An automatic protection mechanism is available for systems that need to run at peak CPU clock speed but cannot guarantee a high enough supply voltage for that clock speed. See the LVDTBEN bit in the ["VLT_CR Register"](#) on [page 514](#) for more information.

Table 11-2. OSC_CR0[2:0] Bits: CPU Speed

Bits	6 MHz Internal Main Oscillator *	24 MHz Internal Main Oscillator	External Clock
000b	750 kHz	3 MHz	EXTCLK/ 8
001b	1.5 MHz	6 MHz	EXTCLK/ 4
010b	3 MHz	12 MHz	EXTCLK/ 2
011b	6 MHz	24 MHz	EXTCLK/ 1
100b	375 kHz	1.5 MHz	EXTCLK/ 16
101b	187.5 kHz	750 kHz	EXTCLK/ 32
110b	93.7 kHz	187.5 kHz	EXTCLK/ 128
111b	46.9 kHz	93.7 kHz	EXTCLK/ 256

* For PSoC devices that support the slow IMO option, see the ["Architectural Description"](#) on [page 113](#).

For additional information, refer to the [OSC_CR0 register](#) on [page 291](#).

11.2.2 OSC_CR2 Register

Address	Name	Bit 7	Bit 6	Bit 5	Bit 4	Bit 3	Bit 2	Bit 1	Bit 0	Access
1,E2h	OSC_CR2	PLLGAIN					EXTCLKEN	IMODIS	SYSCLKX2DIS	RW : 00

The Oscillator Control Register 2 (OSC_CR2) is used to configure various features of internal clock sources and clock nets.

Bit 7: PLLGAIN. This is the only bit in the OSC_CR2 register that directly influences the PLL. When set, this bit keeps the PLL in Low Gain mode.

If this bit is held low, the lock time is less than 10 ms. If this bit is held high, the lock time is on the order of 50 ms. After lock is achieved, it is recommended that this bit be forced high to decrease the jitter on the output. If longer lock time is tolerable, the PLLGAIN bit can be held high all the time.

Bit 2: EXTCLKEN. When the EXTCLKEN bit is set, the external clock becomes the source for the internal clock tree, SYSCLK, which drives most PSoC device clocking functions. All external and internal signals, including the 32 kHz clock, whether derived from the Internal Low Speed Oscillator (ILO) or the crystal oscillator, are synchronized to

this clock source. If an external clock is enabled, PLL mode should be off. The external clock input is located on port P1[4]. When using this input, the pin drive mode should be set to High Z (not High Z analog).

Bit 1: IMODIS. When IMODIS is set, the Internal Main Oscillator (IMO) is disabled. If the doubler is enabled (SYSCLKX2DIS=0), the IMO is forced on.

Bit 0: SYSCLKX2DIS. When SYSCLKX2DIS is set, the IMO's doubler is disabled. This will result in a reduction of overall device power, on the order of 1 mA. It is advised that any application that does not require this doubled clock should have it turned off. During emulation with the In-Circuit Emulator (ICE), the IMO's doubler is always active regardless of the status of SYSCLKX2DIS.

For additional information, refer to the [OSC_CR2 register on page 293](#).

12. Sleep and Watchdog



This chapter discusses the Sleep and Watchdog operations and their associated registers. For a complete table of the Sleep and Watchdog registers, refer to the “[Summary Table of the Core Registers](#)” on page 60. For a quick reference of all PSoC registers in address order, refer to the [Register Details](#) chapter on page 147.

12.1 Architectural Description

Device components that are involved in Sleep and Watchdog operation are the selected 32 kHz clock (external crystal or internal), the sleep timer, the Sleep bit in the CPU_SCR0 register, the sleep circuit (to sequence going into and coming out of sleep), the bandgap refresh circuit (to periodically refresh the reference voltage during sleep), and the **watchdog timer**.

The goal of Sleep operation is to reduce average power consumption as much as possible. The system has a sleep state that can be initiated under firmware control. In this state, the CPU is stopped at an instruction boundary and the 24/48 MHz oscillator (IMO), the Flash memory module, and bandgap voltage reference are powered down. The only blocks that remain in operation are the 32 kHz oscillator (external crystal or internal), **PSoC blocks** clocked from the 32 kHz clock selection, and the supply voltage monitor circuit.

Analog PSoC blocks have individual power down settings that are controlled by firmware, independently of the sleep state. Continuous time analog blocks may remain in operation, since they do not require a clock source. Typically, switched capacitor analog blocks will not operate, since the internal sources of clocking for these blocks are stopped.

The system can only wake up from sleep as a result of an interrupt or reset event. The sleep timer can provide periodic interrupts to allow the system to wake up, poll peripherals, or do real-time functions, and then go to sleep again. The GPIO (pin) interrupt, supply monitor interrupt, analog column interrupts, and timers clocked externally or from the 32 kHz clock are examples of **asynchronous** interrupts that can also be used to wake the system up.

The Watchdog Timer (WDT) circuit is designed to assert a **hardware reset** to the device after a pre-programmed interval, unless it is periodically serviced in firmware. In the event that an unexpected execution path is taken through the code, this functionality serves to reboot the system. It can also restart the system from the CPU halt state.

Once the WDT is enabled, it can only be disabled by an External Reset (XRES) or a Power On Reset (POR). A WDT reset will leave the WDT enabled. Therefore, if the WDT is used in an application, all code (including initialization code) must be written as though the WDT is enabled.

12.1.1 32 kHz Clock Selection

By default, the 32 kHz clock source is the Internal Low Speed Oscillator (ILO). Optionally, the 32.768 kHz External Crystal Oscillator (ECO) may be activated. This selection is made in bit 7 of the OSC_CR0 register. Selecting the ECO as the source for the 32 kHz clock allows the sleep timer and sleep interrupt to be used in real-time clock applications. Regardless of the clock source selected, the 32 kHz clock plays a key role in sleep functionality. It runs continuously and is used to sequence system wakeup. It is also used to periodically refresh the bandgap voltage during sleep.

Refer to the [External Crystal Oscillator \(ECO\)](#) chapter on page 119, for details on activating an external crystal oscillator.

12.1.2 Sleep Timer

The sleep timer is a 15-bit up counter clocked by the currently selected 32 kHz clock source, either the ILO or ECO. This timer is always enabled. The exception to this is within an **ICE** (in-circuit **emulator**) in **debugger** mode and when the Stop bit in the CPU_SCR0 is set; the sleep timer is disabled, so that the user will not get continual watchdog resets when a breakpoint is hit in the debugger environment.

If the associated sleep timer interrupt is enabled, a periodic interrupt to the CPU is generated based on the sleep interval selected from the OSC_CR0 register. The sleep timer functionality does not need to be directly associated with the sleep state. It can be used as a general purpose timer interrupt regardless of sleep state.

The reset state of the sleep timer is a count value of all zeros. There are two ways to reset the sleep timer. Any hardware reset, (that is, POR, XRES, or Watchdog Reset (WDR) will reset the sleep timer. There is also a method that allows the user to reset the sleep timer in firmware. A write of 38h to the RES_WDT register clears the sleep timer.

Note Any write to the RES_WDT register also clears the watchdog timer.

Clearing the sleep timer may be done at anytime to synchronize the sleep timer operation to CPU processing. A good example of this is after POR. The CPU hold-off, due to voltage ramp and others, may be significant. In addition, a significant amount of program initialization may be required. However, the sleep timer starts counting immediately after POR and will be at an arbitrary count when user code begins execution. In this case, it may be desirable to clear the sleep timer before enabling the sleep interrupt initially, to ensure that the first sleep period is a full interval.

12.2 Application Description

The following are notes regarding sleep as it relates to firmware and application issues.

Note 1 If an interrupt is pending, enabled, and scheduled to be taken at the instruction boundary after the write to the sleep bit, the system will not go to sleep. The instruction will still execute, but it will not be able to set the SLEEP bit in the CPU_SCR0 register. Instead, the interrupt will be taken and the effect of the sleep instruction is ignored.

Note 2 The Global Interrupt Enable (CPU_F register) does not need to be enabled to wake the system out of sleep state. Individual interrupt enables, as set in the interrupt mask registers, are sufficient. If the Global Interrupt Enable is not set, the CPU will not service the ISR associated with that interrupt. However, the system will wake up and continue executing instructions from the point at which it went to sleep. In this case, the user must manually clear the pending interrupt or subsequently enable the Global Interrupt Enable bit and let the CPU take the ISR. If a pending interrupt is not cleared, it will be continuously asserted. Although the sleep bit may be written and the sleep sequence executed as soon as the device enters Sleep mode, the Sleep bit is cleared by the pending interrupt and Sleep mode is exited immediately.

Note 3 On wake up, the instruction immediately after the sleep instruction is executed before the interrupt service routine (if enabled). The instruction after the sleep instruction is pre-fetched, before the system actually goes to sleep. Therefore, when an interrupt occurs to wake the system up, the pre-fetched instruction is executed and then the interrupt service routine is executed. (If the Global Interrupt Enable is not set, instruction execution will just continue where it left off before sleep.)

Note 4 If PLL mode is enabled, CPU frequency must be reduced to 3 MHz before going to sleep. Since the PLL will overshoot as it attempts to re-lock after wakeup, the CPU frequency must be relatively low. It is recommended to wait 10 ms after wakeup, before normal CPU operating frequency may be restored.

Note 5 Analog power must be turned off by firmware before going to sleep, to achieve the smallest sleep current. The system sleep state does not control the analog array. There are individual power controls for each analog block and global power controls in the reference block. These power controls must be manipulated by firmware.

Note 6 If the Global Interrupt Enable bit is disabled, it can be safely enabled just before the instruction that writes the sleep bit. It is usually undesirable to get an interrupt on the instruction boundary, just before writing the sleep bit. This means that on the return from interrupt, the sleep command will be executed, possibly bypassing any firmware preparations that must be made in order to go to sleep. To prevent this, disable interrupts before preparations are made. After sleep preparations, enable global interrupts and write the sleep bit with the two consecutive instructions as follows.

```
and f,~01h           // disable global interrupts
                    // (prepare for sleep, could
                    // be many instructions)
or f,01h            // enable global interrupts
mov reg[ffh],08h    // Set the sleep bit
```

Due to the timing of the Global Interrupt Enable instruction, it is not possible for an interrupt to occur immediately after that instruction. The earliest the interrupt could occur is after the next instruction (write to the Sleep bit) has been executed. Therefore, if an interrupt is pending, the sleep instruction is executed; but as described in Note 1, the sleep instruction will be ignored. The first instruction executed after the ISR is the instruction after sleep.

12.3 Register Definitions

The following registers are associated with Sleep and Watchdog and are listed in address order. Each register description has an associated register table showing the bit structure for that register. The bits that are grayed out in the tables below are reserved bits and are not detailed in the register descriptions. Note that reserved bits should always be written with a value of '0'. For a complete table of the Sleep and Watchdog registers, refer to the “Summary Table of the Core Registers” on page 60.

12.3.1 INT_MSK0 Register

Address	Name	Bit 7	Bit 6	Bit 5	Bit 4	Bit 3	Bit 2	Bit 1	Bit 0	Access
0, E0h	INT_MSK0	VC3	Sleep	GPIO	Analog 3	Analog 2	Analog 1	Analog 0	V Monitor	RW : 00
2 Cols.		VC3	Sleep	GPIO			Analog 1	Analog 0	V Monitor	
1 Col.		VC3	Sleep	GPIO			Analog 1		V Monitor	

The Interrupt Mask Register 0 (INT_MSK0) is used to enable the individual sources' ability to create pending interrupts.

Depending on your PSoC device's characteristics, only certain bits are accessible to be read or written in the analog column dependent INT_MSK0 register. (Refer to the table titled “PSoC Device Characteristics” on page 22.) In the table above, the analog column numbers are listed to the right in the Address column.

Bits 7 and 5 to 0. The INT_MSK0 register holds bits that are used by several different resources. For a full discussion of the INT_MSK0 register, see the [Interrupt Controller chapter on page 95](#).

Bit 6: Sleep. This bit controls the sleep interrupt enable.

For additional information, refer to the [INT_MSK0 register on page 239](#).

12.3.2 RES_WDT Register

Address	Name	Bit 7	Bit 6	Bit 5	Bit 4	Bit 3	Bit 2	Bit 1	Bit 0	Access
0, E3h	RES_WDT	WDSL_Clear[7:0]								W : 00

The Reset Watchdog Timer Register (RES_WDT) is used to clear the watchdog timer (a write of any value) and clear both the watchdog timer and the sleep timer (a write of 38h).

Bits 7 to 0: WDSL_Clear[7:0]. The Watchdog Timer (WDT) write-only register is designed to timeout at three roll-over events of the sleep timer. Therefore, if only the WDT is cleared, the next Watchdog Reset (WDR) will occur anywhere from two to three times the current sleep interval setting. If the sleep timer is near the beginning of its count, the watchdog timeout will be closer to three times. However, if

the sleep timer is very close to its **terminal count**, the watchdog timeout will be closer to two times. To ensure a full three times timeout, both the WDT and the sleep timer may be cleared. In applications that need a real-time clock, and thus cannot reset the sleep timer when clearing the WDT, the duty cycle at which the WDT must be cleared should be no greater than two times the sleep interval.

For additional information, refer to the [RES_WDT register on page 242](#).

12.3.3 CPU_SCR1 Register

Address	Name	Bit 7	Bit 6	Bit 5	Bit 4	Bit 3	Bit 2	Bit 1	Bit 0	Access
x,FEh	CPU_SCR1	IRESS			SLIMO	ECO EXW *	ECO EX *		IRAMDIS	# : 00

LEGEND

- x An "x" before the comma in the address field indicates that this register can be read or written to no matter what bank is used.
- # Access is bit specific. Refer to the [Register Details chapter on page 147](#) for additional information.
- * Bits 3 and 2 (ECO EXW and ECO EX, respectively) cannot be used by the CY8C27x43 for silicon revision A, and by the CY8C24x23 and CY8C22x13 PSoC devices.

The System Status and Control Register 1 (CPU_SCR1) is used to convey the status and control of events related to internal resets and watchdog reset.

Bit 7: IRESS. The Internal Reset Status bit is a read only bit that may be used to determine if the booting process occurred more than once.

When this bit is set, it indicates that the SROM SWBootReset code was executed more than once. If this bit is not set, the SWBootReset was executed only once. In either case, the SWBootReset code will not allow execution from code stored in Flash until the M8C Core is in a safe operating mode with respect to supply voltage and Flash operation. There is no need for concern when this bit is set. It is provided for systems which may be sensitive to boot time, so that they can determine if the normal one-pass boot time was exceeded. For more information on the SWBootReset code see the [Supervisory ROM \(SROM\) chapter on page 73](#).

Bit 4: SLIMO. When set, the Slow IMO bit allows the active power dissipation of the PSoC device to be reduced by slowing down the IMO from 24 MHz to 6 MHz. The IMO trim value must also be changed when SLIMO is set (see ["Engaging Slow IMO \(SLIMO\)" on page 114](#)). When not in external clocking mode, the IMO is the source for SYSCLK; therefore, when the speed of the IMO changes, so will SYSCLK.

Bit 3: ECO EXW. The ECO Exists Written bit is used as a status bit to indicate that the ECO EX bit has been previ-

ously written to. It is read only. When this bit is a '1', this indicates that the CPU_SCR1 register has been written to and is now locked. When this bit is a '0', the register has not been written to since the last reset event. Note that this bit cannot be used by the CY8C27x43 for silicon revision A, and by the CY8C24x23 and CY8C22x13 PSoC devices.

Bit 2: ECO EX. The ECO Exists bit serves as a flag to the hardware, to indicate that an external crystal **oscillator** exists in the system. Just after boot, it may be written *only once* to a value of '1' (crystal exists) or '0' (crystal does not exist). If the bit is '0', a switch-over to the ECO is locked out by hardware. If the bit is '1', hardware allows the firmware to freely switch between the ECO and ILO. It should be written as early as possible after a **Power On Reset (POR)** or **External Reset (XRES)** event, where it is assumed that program execution integrity is high. Note that this bit cannot be used by the CY8C27x43 for silicon revision A, and by the CY8C24x23 and CY8C22x13 PSoC devices.

Bit 0: IRAMDIS. The Initialize RAM Disable bit is a control bit that is readable and writeable. The **default value** for this bit is '0', which indicates that the maximum amount of SRAM should be initialized on watchdog reset to a value of 00h. When the bit is '1', the minimum amount of SRAM is initialized after a watchdog reset. For more information on this bit, see the ["SROM Function Descriptions" on page 74](#).

For additional information, refer to the [CPU_SCR1 register on page 251](#).

12.3.4 CPU_SCR0 Register

Address	Name	Bit 7	Bit 6	Bit 5	Bit 4	Bit 3	Bit 2	Bit 1	Bit 0	Access
x,FFh	CPU_SCR0	GIES		WDRS	PORS	Sleep			STOP	# : XX

LEGEND

- X The value for power on reset is unknown.
- x An "x" before the comma in the address field indicates that this register can be read or written to no matter what bank is used.
- # Access is bit specific. Refer to register detail for additional information.

The System Status and Control Register 0 (CPU_SCR0) is used to convey the status and control of events for various functions of a PSoC device.

Bit 7: GIES. The Global Interrupt Enable Status bit is a read only status bit and its use is discouraged. The GIES bit is a legacy bit which was used to provide the ability to read the GIE bit of the CPU_F register. However, the CPU_F register is now readable. When this bit is set, it indicates that the GIE bit in the CPU_F register is also set which, in turn, indicates that the microprocessor will service interrupts.

Bit 5: WDRS. The WatchDog Reset Status bit may not be set. It is normally '0' and automatically set whenever a watchdog reset occurs. The bit is readable and clearable by writing a zero to its bit position in the CPU_SCR0 register.

Bit 4: PORS. The Power On Reset Status (PORS) bit, which is the watchdog enable bit, is set automatically by a POR or External Reset (XRES). If the bit is cleared by user code, the watchdog timer is enabled. Once cleared, the only way to reset the PORS bit is to go through a POR or XRES. Thus, there is no way to disable the watchdog timer, other than to go through a POR or XRES.

Bit 3: Sleep. The Sleep bit is used to enter Low Power Sleep mode when set. To wake up the system, this register bit is cleared asynchronously by any enabled interrupt. There are two special features of this register bit that ensures proper Sleep operation. First, the write to set the register bit is blocked, if an interrupt is about to be taken on that instruction boundary (immediately after the write). Second, there is a hardware interlock to ensure that, once set, the sleep bit may not be cleared by an incoming interrupt until the sleep circuit has finished performing the sleep sequence and the system-wide power down signal has been asserted. This prevents the sleep circuit from being interrupted in the middle of the process of system power down, possibly leaving the system in an indeterminate state.

Bit 0: STOP. The STOP bit is readable and writeable. When set, the PSoC M8C will stop executing code until a reset event occurs. This can be either a POR, WDR, or XRES. If an application wants to stop code execution until a reset, the preferred method would be to use the HALT instruction rather than a register write to this bit.

For additional information, refer to the [CPU_SCR0 register on page 252](#).

12.3.5 OSC_CR0 Register

Address	Name	Bit 7	Bit 6	Bit 5	Bit 4	Bit 3	Bit 2	Bit 1	Bit 0	Access
1,E0h	OSC_CR0	32k Select	PLL Mode	No Buzz	Sleep[1:0]		CPU Speed[2:0]			RW : 00

The Oscillator Control Register 0 (OSC_CR0) is used to configure various features of internal clock sources and clock nets.

Bit 7: 32k Select. By default, the 32 kHz clock source is the Internal Low Speed Oscillator (ILO). Optionally, the 32.768 kHz External Crystal Oscillator (ECO) may be selected.

Bit 6: PLL Mode. This is the only bit in the OSC_CR0 register that directly influences the Phase Locked Loop (PLL). When set, this bit enables the PLL. The EXTCLKEN bit in the OSC_CR2 register should be set low during PLL operation. For information on the PLL, refer to the [Phase-Locked Loop \(PLL\) chapter on page 125](#).

Bit 5: No Buzz. Normally, when the Sleep bit is set in the CPU_SCR register, all PSoC device systems are powered down, including the bandgap reference. However, to facilitate the detection of **POR** and **LVD** events at a rate higher than the sleep interval, the bandgap circuit is powered up periodically for about 60 μ s at the Sleep System Duty Cycle (set in ECO_TR), which is independent of the sleep interval and typically higher. When the No Buzz bit is set, the Sleep System Duty Cycle value is overridden and the bandgap circuit is forced to be on during sleep. This results in a faster response to an LVD or POR event (continuous detection as opposed to periodic detection), at the expense of slightly higher average sleep current.

Bits 4 and 3: Sleep[1:0]. The available sleep interval selections are shown in [Table 12-1](#). The accuracy of the sleep intervals are dependent on the accuracy of the oscillator used.

Table 12-1. Sleep Interval Selections

Sleep Interval OSC_CR[4:3]	Sleep Timer Clocks	Sleep Period (nominal)	Watchdog Period (nominal)
00b (default)	64	1.95 ms	6 ms
01b	512	15.6 ms	47 ms
10b	4,096	125 ms	375 ms
11b	32,768	1 sec	3 sec

Bits 2 to 0: CPU Speed[2:0]. The PSoC M8C may operate over a range of CPU clock speeds (see [Table 12-2](#)), allowing the M8C's performance and power requirements to be tailored to the application.

The reset value for the CPU Speed bits is zero; therefore, the default CPU speed is one-eighth of the clock source. The Internal Main Oscillator (IMO) is the default clock source for the CPU speed circuit; therefore, the default CPU speed is 3 MHz.

The CPU frequency is changed with a write to the OSC_CR0 register. There are eight frequencies generated from a power-of-2 divide circuit, which are selected by a 3-bit code. At any given time, the CPU 8-to-1 clock mux is selecting one of the available frequencies, which is resynchronized to the 24 MHz master clock at the output.

Regardless of the CPU Speed bit's setting, if the actual CPU speed is greater than 12 MHz, the 24 MHz operating requirements apply. An example of this scenario is a device that is configured to use an external clock, which is supplying a frequency of 20 MHz. If the CPU speed register's value is 011b, the CPU clock will be 20 MHz. Therefore, the supply voltage requirements for the device are the same as if the part was operating at 24 MHz off of the IMO. The operating voltage requirements are not relaxed until the CPU speed is at 12 MHz or less.

Table 12-2. OSC_CR0[2:0] Bits: CPU Speed

Bits	Internal Main Oscillator	External Clock
000b	3 MHz	EXTCLK/ 8
001b	6 MHz	EXTCLK/ 4
010b	12 MHz	EXTCLK/ 2
011b	24 MHz	EXTCLK/ 1
100b	1.5 MHz	EXTCLK/ 16
101b	750 kHz	EXTCLK/ 32
110b	187.5 kHz	EXTCLK/ 128
111b	93.7 kHz	EXTCLK/ 256

For additional information, refer to the [OSC_CR0 register on page 291](#).

12.3.6 ILO_TR Register

Address	Name	Bit 7	Bit 6	Bit 5	Bit 4	Bit 3	Bit 2	Bit 1	Bit 0	Access
1,E9h	ILO_TR			Bias Trim[1:0]		Freq Trim[3:0]				W : 00

The Internal Low Speed Oscillator Trim Register (ILO_TR) sets the adjustment for the internal low speed oscillator.

The device specific value, placed in the trim bits of this register at boot time, is based on factory testing. ***It is strongly recommended that the user not alter the register value.***

Bits 5 and 4: Bias Trim[1:0]. These two bits are used to set the bias current in the PTAT Current Source. Bit 5 gets inverted, so that a medium bias is selected when both bits are '0'. The bias current is set according to [Table 12-3](#).

Table 12-3. Bias Current in PTAT

Bias Current	Bias Trim [1:0]
Medium Bias	00b
Maximum Bias	01b
Minimum Bias	10b
Not needed *	11b

* About 15% higher than the minimum bias.

Bits 3 to 0: Freq Trim[3:0]. These four bits are used to trim the frequency. Bit 0 is the LSb and bit 3 is the MSb. Bit 3 gets inverted inside the register.

For additional information, refer to the [ILO_TR register on page 299](#).

12.3.7 ECO_TR Register

Address	Name	Bit 7	Bit 6	Bit 5	Bit 4	Bit 3	Bit 2	Bit 1	Bit 0	Access	
1,EBh	ECO_TR	PSSDC[1:0]									W : 00

The External Crystal Oscillator Trim Register (ECO_TR) sets the adjustment for the 32.768 kHz external crystal oscillator.

The value placed in this register is based on factory testing. This register does not adjust the frequency of the external crystal oscillator. ***It is strongly recommended that the user not alter the register value.***

Bits 7 and 6: PSSDC[1:0]. These bits are used to set the sleep duty cycle. These bits should not be altered.

For additional information, refer to the [ECO_TR register on page 301](#).

12.4 Timing Diagrams

12.4.1 Sleep Sequence

The Sleep bit, in the CPU_SCR0 register, is an input into the sleep logic circuit. This circuit is designed to sequence the device into and out of the hardware sleep state. The hardware sequence to put the device to sleep is shown in Figure 12-1 and is defined as follows.

1. Firmware sets the SLEEP bit in the CPU_SCR0 register. The Bus Request (BRQ) signal to the CPU is immediately asserted: This is a request by the system to halt CPU operation at an instruction boundary.
2. The CPU issues a Bus Request Acknowledge (BRA) on the following **positive edge** of the CPU clock.
3. The sleep logic waits for the following **negative edge** of the CPU clock and then asserts a system-wide Power Down (PD) signal. In Figure 12-1, the CPU is halted and the system-wide power down signal is asserted.

The system-wide PD signal controls three major circuit blocks: the Flash memory module, the Internal Main Oscillator (24/48 MHz oscillator that is also called the IMO), and the bandgap voltage reference. These circuits transition into a zero power state. The only operational circuits on the PSoC device are the ILO (or optional ECO), the bandgap refresh circuit, and the supply voltage monitor circuit. Note that the system sleep state does not apply to the analog array. Power down settings for individual analog blocks and references must be done in firmware, prior to executing the sleep instruction.

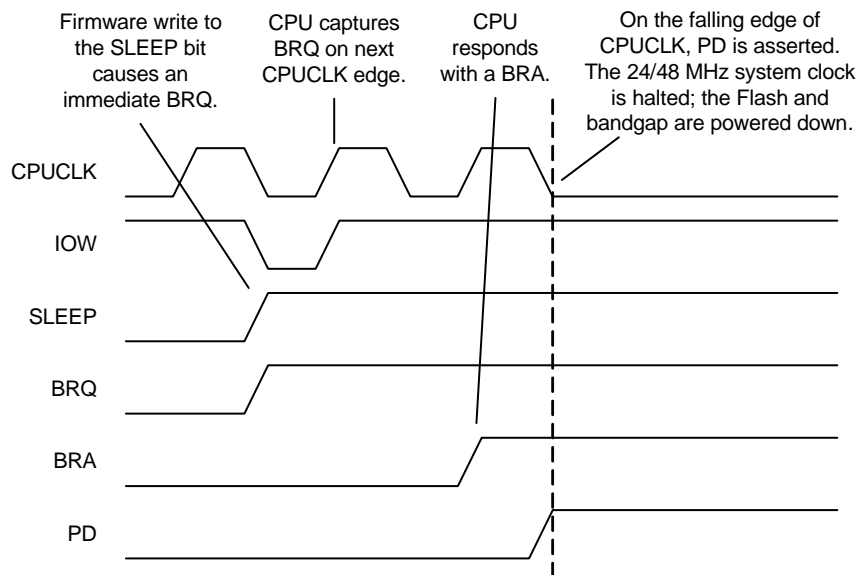

Figure 12-1. Sleep Sequence

12.4.2 Wake Up Sequence

Once asleep, the only event that can wake the system up is an interrupt. The Global Interrupt Enable of the CPU flag register does not need to be set. Any unmasked interrupt will wake the system up. It is optional for the CPU to actually take the interrupt after the wakeup sequence.

The wake up sequence is synchronized to the 32 kHz clock for purposes of sequencing a startup delay, to allow the Flash memory module enough time to power up before the CPU asserts the first read access. Another reason for the delay is to allow the IMO, bandgap, and LVD/POR circuits time to settle before actually being used in the system. As shown in Figure 12-2, the wake up sequence is as follows.

1. The wake up interrupt occurs and is synchronized by the negative edge of the 32 kHz clock.

2. At the following positive edge of the 32 kHz clock, the system-wide PD signal is negated. The Flash memory module, IMO, and bandgap any POR/LVD circuits are all powered up to a normal operating state.
3. At the next positive edge of the 32 kHz clock, the values of the bandgap are settled and sampled.
4. At the following negative edge of the 32 kHz clock (after about 15 μ s, nominal). The values of the POR/LVD signals have settled and are sampled. The BRQ signal is negated by the sleep logic circuit. On the following CPU clock, BRA is negated by the CPU and instruction execution resumes.

The wake up times (interrupt to CPU operational) will range from two to three 32 kHz cycles or 61 - 92 μ s (nominal).

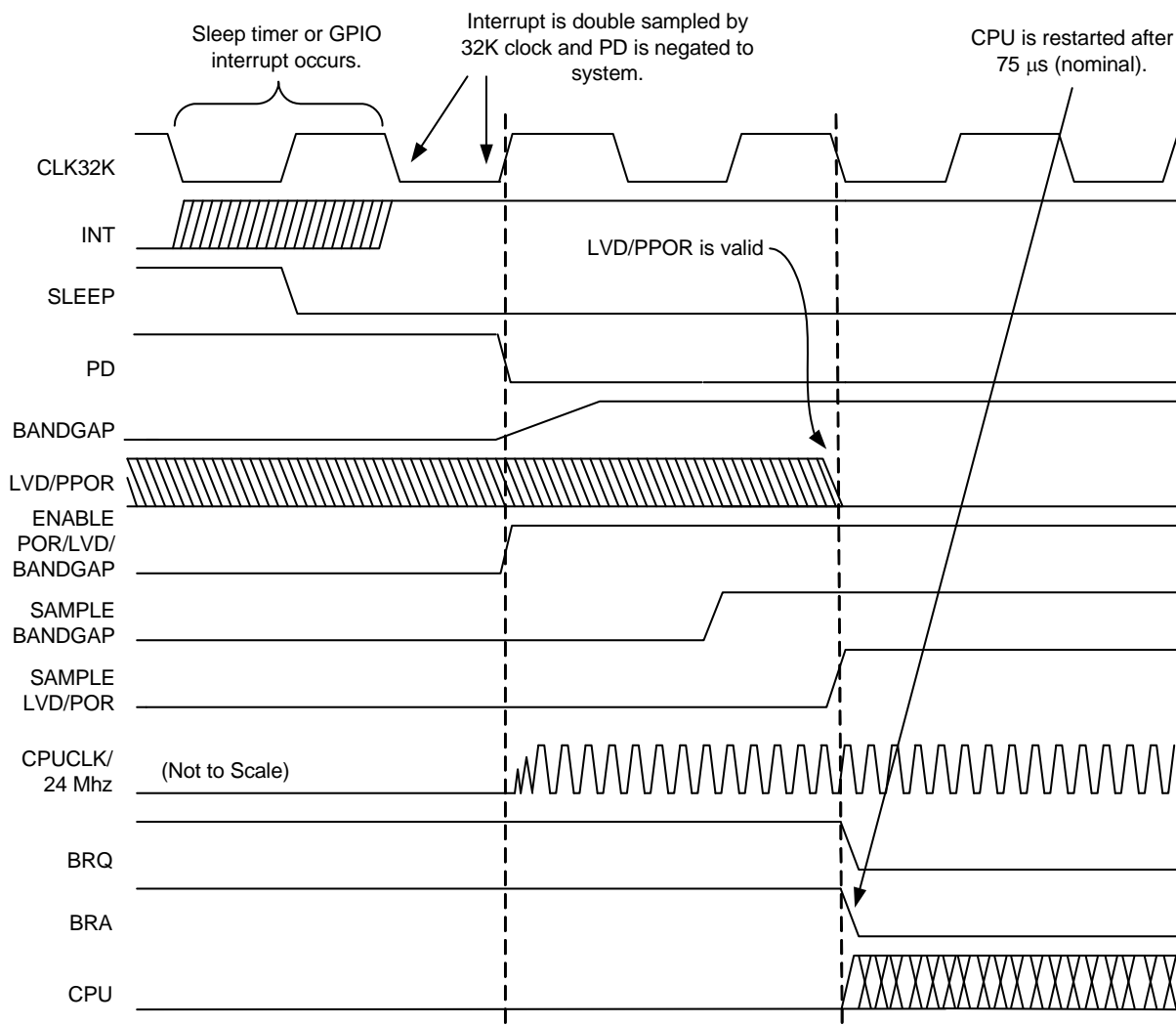

Figure 12-2. Wakeup Sequence

12.4.3 Bandgap Refresh

During normal operation, the bandgap circuit provides a voltage reference (VRef) to the system, for use in the analog blocks, Flash, and **low voltage detect (LVD)** circuitry. Normally, the bandgap output is connected directly to the VRef signal. However, during sleep, the **bandgap reference** generator block and LVD circuits are completely powered down. The bandgap and LVD blocks are periodically re-enabled during sleep, in order to monitor for low voltage conditions. This is accomplished by turning on the bandgap periodically, allowing it time to start up for a full 32 kHz clock period, and connecting it to VRef to refresh the reference voltage for the following 32 kHz clock period as shown in Figure 12-3.

During the second 32 kHz clock period of the refresh cycle, the LVD circuit is allowed to settle during the **high time** of the 32 kHz clock. During the low period of the second 32 kHz clock, the LVD interrupt is allowed to occur.

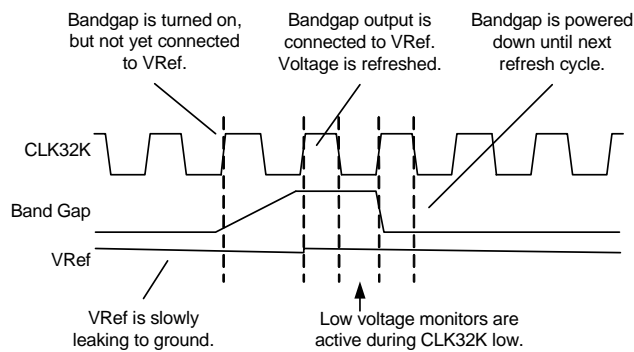

Figure 12-3. Bandgap Refresh Operation

The rate at which the refresh occurs is related to the 32 kHz clock and controlled by the Power System Sleep Duty Cycle (PSSDC), bits [7:6] of the ECO_TR register). Table 12-4 enumerates the available selections. The default setting (256 sleep timer counts) is applicable for many applications, giving a typical average device current under 5 μ A.

Table 12-4. Power System Sleep Duty Cycle Selections

PSSDC	Sleep Timer Counts	Period (Nominal)
00b (default)	256	8 ms
01b	1024	31.2 ms
10b	64	2 ms
11b	16	500 μ s

12.4.4 Watchdog Timer

On device boot up, the Watchdog Timer (WDT) is initially disabled. The PORS bit in the system control register controls the enabling of the WDT. On boot, the PORS bit is initially set to '1', indicating that either a POR or XRES event has occurred. The WDT is enabled by clearing the PORS bit. Once this bit is cleared and the watchdog timer is enabled, it cannot be subsequently disabled. (The PORS bit cannot be set to '1' in firmware; it can only be cleared.)

The only way to disable the Watchdog function, after it is enabled, is through a subsequent POR or XRES. Although the WDT is disabled during the first time through initialization code after a POR or XRES, all code should be written as if it is enabled (that is, the WDT should be cleared periodically). This is because, in the initialization code after a WDR event, the watchdog timer is enabled so all code must be aware of this.

The watchdog timer is three counts of the sleep timer interrupt output. The watchdog interval is three times the selected sleep timer interval. The available selections for the watchdog interval are shown in Table 12-1. When the sleep timer interrupt is asserted, the watchdog timer increments. When the counter reaches three, a terminal count is asserted. This terminal count is registered by the 32 kHz clock. Therefore, the WDR (Watchdog Reset) signal will go high after the following edge of the 32 kHz clock and be held asserted for one cycle (30 μ s nominal). The **flip-flop** that registers the WDT terminal count is not reset by the WDR signal when it is asserted, but is reset by all other resets. This timing is shown in Figure 12-4.

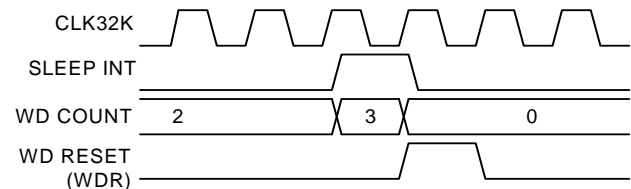

Figure 12-4. Watchdog Reset

Once enabled, the WDT must be periodically cleared in firmware. This is accomplished with a write to the RES_WDT register. This write is data independent, so any write will clear the watchdog timer. (Note that a write of 38h will also clear the sleep timer.) If for any reason the firmware fails to clear the WDT within the selected interval, the circuit will assert WDR to the device. WDR is equivalent in effect to any other reset. All internal registers are set to their reset state, see the table titled "Details of Functionality for Various Resets" on page 507. An important aspect to remember about WDT resets is that RAM initialization can be disabled (IRAMDIS in the CPU_SCR1 register). In this case, the SRAM contents are unaffected; so that when a WDR occurs, program variables are persistent through this reset.

In practical application, it is important to know that the watchdog timer interval can be anywhere between two and

three times the sleep timer interval. The only way to guarantee that the WDT interval is a full three times that of the sleep interval is to clear the sleep timer (write 38h) when clearing the WDT register. However, this is not possible in applications that use the sleep timer as a real-time clock. In the case where firmware clears the WDT register without clearing the sleep timer, this can occur at any point in a given sleep timer interval. If it occurs just before the terminal count of a sleep timer interval, the resulting WDT interval will be just over two times that of the sleep timer interval.

12.5 Power Consumption

Sleep mode power consumption consists of the items in the following tables.

In Table 12-5, the typical block currents shown do not represent maximums. These currents do not include any analog block currents that may be on during Sleep mode.

Table 12-5. Continuous Currents

IPOR	1 μ A
ICLK32K (ILO/ECO)	1 μ A

While the CLK32K can be turned off in Sleep mode, this mode is not useful since it makes it impossible to restart unless an imprecise power on reset (IPOR) occurs. (The Sleep bit can not be cleared without CLK32K.) During the sleep mode buzz, the bandgap is on for two cycles and the LVD circuitry is on for one cycle. Time-averaged currents from periodic sleep mode 'buzz', with periodic count of N, are listed in Table 12-6.

Table 12-6. Time-Averaged Currents

IBG (Bandgap)	$(2/N) * 60 \mu$ A
ILVD (LVD comparators)	$(2/N) * 50 \mu$ A

Table 12-7 lists example currents for N=256 and N=1024. Device leakage currents add to the totals in the table.

Table 12-7. Example Currents

	N=256	N=1024
IPOR	1	1
CLK32K	1	1
IBG	0.46	0.12
ILVD	0.4	0.1
Total	2.9 μ A	2.2 μ A

Section C: Register Reference



The Register Reference section discusses the registers of the PSoC device. It lists all the registers in mapping tables, in address order. For easy reference, each register is linked to the page of a detailed description located in the next chapter. This section encompasses the following chapter:

- [Register Details on page 147](#)

Register General Conventions

The register conventions specific to this section and the Register Details chapter are listed in the following table.

Register Conventions

Convention	Description
Empty, grayed-out table cell	Illustrates a reserved bit or group of bits.
'x' before the comma in an address	Indicates the register exists in register bank 1 and register bank 2.
'x' in a register name	Indicates that there are multiple instances/address ranges of the same register.
R	Read register or bit(s)
W	Write register or bit(s)
L	Logical register or bit(s)
C	Clearable register or bit(s)
#	Access is bit specific

Register Naming Conventions

The register naming convention specific to this section for arrays of PSoC blocks and their registers is:

<Prefix>mn<Suffix>
where m=row index, n=column index

Therefore, ASD13CR3 is a register for an analog PSoC block in row 1 column 3.

Register Mapping Tables

The PSoC device has a total register address space of 512 bytes. The register space is also referred to as IO space and is broken into two parts. The XIO bit in the Flag register (CPU_F) determines which bank the user is currently in. When the XIO bit is set, the user is said to be in the "extended" address space or the "configuration" registers.

The table below presents mapping exceptions for the CY8C21x34, CY8C21x23, CY7C603xx, and CYWUSB6953 PSoC devices. These register exceptions are also tagged with an asterisk (*) in the register mapping tables that follow. The USB CY8C24x94 and CY7C64215 PSoC devices have their own mapping tables after each bank's table.

Mapping Exceptions

Register Name	Exception Name	Description
ACBxxCR1	ACExxCR1	Analog 2 column limited functionality registers that use Type E blocks. Refer to the following register details: "ACExxCR1" on page 192, "ACExxCR2" on page 194, "ASExxCR0" on page 196, and "ASExxCR0" on page 196.
ACBxxCR2	ACExxCR2	
ASCxxCR0	ASE10CR0	
ASDxxCR0	ASE11CR0	

Refer to the individual PSoC device data sheets for device-specific register mapping information.

13. Register Details



This chapter is a reference for all the PSoC device registers in address order, for Bank 0 and Bank 1. The most detailed descriptions of the PSoC registers are in the Register Definitions section of each chapter. The registers that are in both banks are incorporated with the Bank 0 registers, designated with an 'x', rather than a '0' preceding the comma in the address. Bank 0 registers are listed first and begin on page 149. Bank 1 registers are listed second and begin on page 253. A condensed view of all the registers is shown in the "Register Map Bank 0 Table: User Space" on page 142 and the "Register Map Bank 1 Table: Configuration Space" on page 143.

13.1 Maneuvering Around the Registers

For ease-of-use, this chapter has been formatted so that there is one register per page, although some registers use two pages. On each page, from top to bottom, there are four sections:

1. Register name and address (from lowest to highest).
2. Register table showing the bit organization, with reserved bits grayed out.
3. Written description of register specifics or links to additional register information.
4. Detailed register bit descriptions.

Note that some registers are directly related to the digital and analog functions; therefore, these registers might have more than one register table (number 2 above). This is due to the fact that the PSoC devices have different digital row and analog column characteristics which use different bits in the same register. To find out the number of digital rows and analog columns your PSoC device has, refer to the table below. Note that the CY8C21x34, CY8C21x23, CY7C603xx, and CYWUSB6953 PSoC devices have limited functionality for their four analog blocks.

PSoC Device Characteristics

PSoC Part Number	Digital IO	Digital Rows	Digital Blocks	Analog Inputs	Analog Outputs	Analog Columns	Analog Blocks
CY8C29x66 CY8CPLC20 CY8CLED16P01	64	4	16	12	4	4	12
CY8C27x43	44	2	8	12	4	4	12
CY8C24x94	50	1	4	48	2	2	6
CY8C24x23	24	1	4	12	2	2	6
CY8C24x23A	24	1	4	12	2	2	6
CY8C22x13	16	1	4	8	1	1	3
CY8C21x34	28	1	4	28	0	2	4 *
CY8C21x23	16	1	4	8	0	2	4 *
CY7C64215	50	1	4	48	2	2	6
CY7C603xx	28	1	4	28	0	2	4 *
CYWUSB6953	28	1	4	28	0	2	4 *
CY8CNP1xx	33	4	16	12	4	4	12

* Limited analog functionality (designated "2L" in register tables).

Use the register tables, in addition to the detailed register bit descriptions, to determine which bits are reserved for some smaller PSoC devices. Reserved bits are grayed table cells and are not described in the bit description section. Reserved bits should always be written with a value of '0'.

Register Conventions

The following table lists the register conventions that are specific to this chapter.

Register Conventions

Convention	Example	Description
'x' in a register name	ACBxxCR1	Multiple instances/address ranges of the same register
R	R : 00	Read register or bit(s)
W	W : 00	Write register or bit(s)
L	RL : 00	Logical register or bit(s)
C	RC : 00	Clearable register or bit(s)
00	RW : 00	Reset value is 0x00 or 00h
XX	RW : XX	Register is not reset
0,	0,04h	Register is in bank 0
1,	1,23h	Register is in bank 1
x,	x,F7h	Register exists in register bank 0 and register bank 1
2L	2L Column	Register bit table designation for PSoC devices with two column limited functionality
Empty, grayed-out table cell		Reserved bit or group of bits, unless otherwise stated

13.1.1 Register Naming Conventions

There are a few register naming conventions used in this manual to abbreviate repetitious register information by using a lower case 'x' in the register name. The convention to interpret these register names is as follows.

- For all registers, an 'x' before the comma in the address field indicates that the register can be accessed or written to no matter what bank is used. For example, the M8C flag register's (CPU_F) address is 'x,F7h' meaning it is located in bank 0 and bank 1 at F7h.
- For digital block registers, the first 'x' in some register names represents either "B" for basic or "C" for communication. For rows of digital PSoC blocks and their registers, the second 'x' set represents <Prefix>mn<Suffix>, where m=row index, n=column index. Therefore, DCB32CR0 (written DxBxxCR0) is a digital communication register for a digital PSoC block in row 3 column 2.
- For digital row registers, the 'x' in the digital register's name represents the digital row index. For example, the RDIxIS register name encompasses four registers: one for each digital row index and unique address (RDI0IS, RDI1IS, RDI2IS, and RDI3IS).
- For analog column registers, the naming convention for the switched capacitor and continuous time registers and their arrays of PSoC blocks is <Prefix>mn<Suffix>, where m=row index, n=column index. Therefore, ASC21CR2 (written ASCxxCR2) is a register for an analog PSoC block in row 2 column 1

13.2 Bank 0 Registers

The following registers are all in bank 0 and are listed in address order. An 'x' before the comma in the register's address indicates that the register can be accessed independent of the XIO bit in the CPU_F register. Registers that are in both Bank 0 and Bank 1 are listed in address order in Bank 0. For example, the RDIxLT1 register has an address of x,B4h and is in both Bank 0 and Bank 1.

13.2.1 PRTxDR

Port Data Register

Individual Register Names and Addresses:

PRT0DR : 0,00h PRT1DR : 0,04h PRT2DR : 0,08h PRT3DR : 0,0Ch
 PRT4DR : 0,10h PRT5DR : 0,14h PRT6DR : 0,18h PRT7DR : 0,1Ch

	7	6	5	4	3	2	1	0
Access : POR	RW : 00							
Bit Name	Data[7:0]							

This register allows for write or read access of the current logical equivalent of the voltage on the pin.

The CY8C27643 has a 4-bit wide Port 5; the CY8C21x34, CY7C603xx, and CYWUSB6953 have a 4-bit wide Port 3. The upper *nibble* of this register will return the last data bus value when read and should be masked off prior to using this information. For additional information, refer to the "Register Definitions" on page 107 in the GPIO chapter.

Bit	Name	Description
7:0	Data[7:0]	Write value to port or read value from port. Reads return the state of the pin, not the value in the PRTxDR register.

13.2.2 PRTxIE

Port Interrupt Enable Register

Individual Register Names and Addresses:

PRT0IE : 0,01h PRT1IE : 0,05h PRT2IE : 0,09h PRT3IE : 0,0Dh
 PRT4IE : 0,11h PRT5IE : 0,15h PRT6IE : 0,19h PRT7IE : 0,1Dh

	7	6	5	4	3	2	1	0
Access : POR	RW : 00							
Bit Name	Interrupt Enables[7:0]							

This register is used to enable or disable the interrupt enable internal to the GPIO block.

The CY8C27643 has a 4-bit wide Port 5; the CY8C21x34, CY7C603xx, and CYWUSB6953 have a 4-bit wide Port 3. The upper nibble of this register will return the last data bus value when read and should be masked off prior to using this information. For additional information, refer to the “[Register Definitions](#)” on page 107 in the GPIO chapter.

Bit	Name	Description
7:0	Interrupt Enables[7:0]	A bit set in this register will enable the corresponding port pin interrupt. 0 Port pin interrupt disabled for the corresponding pin. 1 Port pin interrupt enabled for the corresponding pin.

13.2.3 PRTxGS

Port Global Select Register

Individual Register Names and Addresses:

PRT0GS : 0,02h PRT1GS : 0,06h PRT2GS : 0,0Ah PRT3GS : 0,0Eh
 PRT4GS : 0,12h PRT5GS : 0,16h PRT6GS : 0,1Ah PRT7GS : 0,1Eh

	7	6	5	4	3	2	1	0
Access : POR	RW : 00							
Bit Name	Global Select[7:0]							

This register is used to select the block for connection to global inputs or outputs.

The CY8C27643 has a 4-bit wide Port 5; the CY8C21x34, CY7C603xx, and CYWUSB6953 have a 4-bit wide Port 3. The upper nibble of this register will return the last data bus value when read and should be masked off prior to using this information. For additional information, refer to the “[Register Definitions](#)” on page 107 in the GPIO chapter.

Bit	Name	Description
7:0	Global Select[7:0]	A bit set in this register will connect the corresponding port pin to an internal global bus. This connection is used to input or output digital signals to or from the digital blocks. 0 Global function disabled. The pin value is determined by the PRTxDR bit value and port configuration registers. 1 Global function enabled. Direction depends on mode bits for the pin (registers PRTxDM0, PRTxDM1, and PRTxDM2).

13.2.4 PRTxDM2

Port Drive Mode Bit 2 Register

Individual Register Names and Addresses:

PRT0DM2 : 0,03h PRT1DM2 : 0,07h PRT2DM2 : 0,0Bh PRT3DM2 : 0,0Fh
 PRT4DM2 : 0,13h PRT5DM2 : 0,17h PRT6DM2 : 0,1Bh PRT7DM2 : 0,1Fh

	7	6	5	4	3	2	1	0
Access : POR	RW : FF							
Bit Name	Drive Mode 2[7:0]							

This register is one of three registers whose combined value determines the unique Drive mode of each bit in a GPIO port.

In this register, there are eight possible drive modes for each port pin. Three mode bits are required to select one of these modes, and these three bits are spread into three different registers (the [PRTxDM0 register on page 253](#), the [PRTxDM1 register on page 254](#), and the PRTxDM2 register). The bit position of the affected port pin (for example, Pin[2] in Port 0) is the same as the bit position of each of the three drive mode register bits that control the Drive mode for that pin (for example: PRT0DM0[2], PRT0DM1[2], and PRT0DM2[2]). The three bits from the three registers are treated as a group. These are referred to as DM2, DM1, and DM0, or together as DM[2:0].

All Drive mode bits are shown in the sub-table below ([210] refers to the combination (in order) of bits in a given bit position); however, this register only controls the **most significant bit (MSb)** of the Drive mode.

The CY8C27643 has a 4-bit wide Port 5; the CY8C21x34, CY7C603xx, and CYWUSB6953 have a 4-bit wide Port 3. The upper nibble of this register will return the last data bus value when read and should be masked off prior to using this information. For additional information, refer to the “[Register Definitions](#)” on page 107 in the GPIO chapter.

The Cy8CNP1xx has a 2 bit wide port 3. MAke certain to mask nonavailable I/O bits while accessing the data register for this port.

Bit	Name	Description																																				
7:0	Drive Mode 2[7:0]	Bit 2 of the Drive mode, for each pin of an 8-bit GPIO port.																																				
		<table border="1"> <thead> <tr> <th>[210]</th> <th>Pin Output High</th> <th>Pin Output Low</th> <th>Notes</th> </tr> </thead> <tbody> <tr> <td>000b</td> <td>Strong</td> <td>Resistive</td> <td></td> </tr> <tr> <td>001b</td> <td>Strong</td> <td>Strong</td> <td></td> </tr> <tr> <td>010b</td> <td>High Z</td> <td>High Z</td> <td>Digital input enabled.</td> </tr> <tr> <td>011b</td> <td>Resistive</td> <td>Strong</td> <td></td> </tr> <tr> <td>100b</td> <td>Slow + strong</td> <td>High Z</td> <td></td> </tr> <tr> <td>101b</td> <td>Slow + strong</td> <td>Slow + strong</td> <td></td> </tr> <tr> <td>110b</td> <td>High Z</td> <td>High Z</td> <td>Reset state. Digital input disabled for zero power.</td> </tr> <tr> <td>111b</td> <td>High Z</td> <td>Slow + strong</td> <td>I2C Compatible mode.</td> </tr> </tbody> </table>	[210]	Pin Output High	Pin Output Low	Notes	000b	Strong	Resistive		001b	Strong	Strong		010b	High Z	High Z	Digital input enabled.	011b	Resistive	Strong		100b	Slow + strong	High Z		101b	Slow + strong	Slow + strong		110b	High Z	High Z	Reset state. Digital input disabled for zero power.	111b	High Z	Slow + strong	I2C Compatible mode.
[210]	Pin Output High	Pin Output Low	Notes																																			
000b	Strong	Resistive																																				
001b	Strong	Strong																																				
010b	High Z	High Z	Digital input enabled.																																			
011b	Resistive	Strong																																				
100b	Slow + strong	High Z																																				
101b	Slow + strong	Slow + strong																																				
110b	High Z	High Z	Reset state. Digital input disabled for zero power.																																			
111b	High Z	Slow + strong	I2C Compatible mode.																																			
		Note A bold digit, in the table above, signifies that the digit is used in this register.																																				

13.2.5 DxBxxDR0

Digital Basic/Communication Type B Block Data Register 0

Individual Register Names and Addresses:

DBB00DR0 : 0,20h	DBB01DR0 : 0,24h	DCB02DR0 : 0,28h	DCB03DR0 : 0,2Ch
DBB10DR0 : 0,30h	DBB11DR0 : 0,34h	DCB12DR0 : 0,38h	DCB13DR0 : 0,3Ch
DBB20DR0 : 0,40h	DBB21DR0 : 0,44h	DCB22DR0 : 0,48h	DCB23DR0 : 0,4Ch
DBB30DR0 : 0,50h	DBB31DR0 : 0,54h	DCB32DR0 : 0,58h	DCB33DR0 : 0,5Ch

	7	6	5	4	3	2	1	0
Access : POR	R : 00							
Bit Name	Data[7:0]							

This register is the data register for a digital block.

The use of this register is dependent on which function is selected for its block. This selection is made in the FN[2:0] bits of the [DxBxxFN register on page 257](#). (For the Timer, Counter, Dead Band, and CRCPRS functions, a read of the DxBxxDR0 register returns 00h and transfers DxBxxDR0 to DxBxxDR2.)

The naming convention for the digital basic/communication and control registers is as follows. The first 'x' in the digital register's name represents either "B" for basic or "C" for communication. For rows of digital PSoC blocks and their registers, the second 'x' set represents [Prefix>mn<Suffix], where m=row index, n=column index. Therefore, DBB21DR0 is a digital basic register for a digital PSoC block in row 2 column 1. Depending on the digital row characteristics of your PSoC device (see the table titled "[PSoC Device Characteristics](#)" on page 307), some addresses may not be available. For additional information, refer to the "[Register Definitions](#)" on page 345 in the Digital Blocks chapter.

Bit	Name	Description																											
7:0	Data[7:0]	Data for selected function.																											
		<table border="0"> <thead> <tr> <th>Block Function</th> <th>Register Function</th> <th>DCB Only</th> </tr> </thead> <tbody> <tr> <td>Timer</td> <td>Count Value</td> <td>No</td> </tr> <tr> <td>Counter</td> <td>Count Value</td> <td>No</td> </tr> <tr> <td>Dead Band</td> <td>Count Value</td> <td>No</td> </tr> <tr> <td>CRCPRS</td> <td>LFSR *</td> <td>No</td> </tr> <tr> <td>SPIM</td> <td>Shifter</td> <td>Yes</td> </tr> <tr> <td>SPIS</td> <td>Shifter</td> <td>Yes</td> </tr> <tr> <td>TXUART</td> <td>Shifter</td> <td>Yes</td> </tr> <tr> <td>RXUART</td> <td>Shifter</td> <td>Yes</td> </tr> </tbody> </table>	Block Function	Register Function	DCB Only	Timer	Count Value	No	Counter	Count Value	No	Dead Band	Count Value	No	CRCPRS	LFSR *	No	SPIM	Shifter	Yes	SPIS	Shifter	Yes	TXUART	Shifter	Yes	RXUART	Shifter	Yes
Block Function	Register Function	DCB Only																											
Timer	Count Value	No																											
Counter	Count Value	No																											
Dead Band	Count Value	No																											
CRCPRS	LFSR *	No																											
SPIM	Shifter	Yes																											
SPIS	Shifter	Yes																											
TXUART	Shifter	Yes																											
RXUART	Shifter	Yes																											
		* <i>Linear Feedback Shift Register (LFSR)</i>																											

13.2.6 DxBxxDR1

Digital Basic/Communication Type B Block Data Register 1

Individual Register Names and Addresses:

DBB00DR1 : 0,21h	DBB01DR1 : 0,25h	DCB02DR1 : 0,29h	DCB03DR1 : 0,2Dh
DBB10DR1 : 0,31h	DBB11DR1 : 0,35h	DCB12DR1 : 0,39h	DCB13DR1 : 0,3Dh
DBB20DR1 : 0,41h	DBB21DR1 : 0,45h	DCB22DR1 : 0,49h	DCB23DR1 : 0,4Dh
DBB30DR1 : 0,51h	DBB31DR1 : 0,55h	DCB32DR1 : 0,59h	DCB33DR1 : 0,5Dh

	7	6	5	4	3	2	1	0
Access : POR	W : 00							
Bit Name	Data[7:0]							

This register is the data register for a digital block.

The use of this register is dependent on which function is selected for its block. This selection is made in the FN[2:0] bits of the [DxBxxFN register on page 257](#). Refer to the [DxBxxDR0 register on page 153](#) for naming convention and digital row availability information. For additional information, refer to the “[Register Definitions](#)” on [page 345](#) in the Digital Blocks chapter.

Bit	Name	Description																											
7:0	Data[7:0]	Data for selected function.																											
		<table border="1"> <thead> <tr> <th>Block Function</th> <th>Register Function</th> <th>DCB Only</th> </tr> </thead> <tbody> <tr> <td>Timer</td> <td>Period</td> <td>No</td> </tr> <tr> <td>Counter</td> <td>Period</td> <td>No</td> </tr> <tr> <td>Dead Band</td> <td>Period</td> <td>No</td> </tr> <tr> <td>CRCPRS</td> <td>Polynomial</td> <td>No</td> </tr> <tr> <td>SPIM</td> <td>TX Buffer</td> <td>Yes</td> </tr> <tr> <td>SPIS</td> <td>TX Buffer</td> <td>Yes</td> </tr> <tr> <td>TXUART</td> <td>TX Buffer</td> <td>Yes</td> </tr> <tr> <td>RXUART</td> <td>Not applicable</td> <td>Yes</td> </tr> </tbody> </table>	Block Function	Register Function	DCB Only	Timer	Period	No	Counter	Period	No	Dead Band	Period	No	CRCPRS	Polynomial	No	SPIM	TX Buffer	Yes	SPIS	TX Buffer	Yes	TXUART	TX Buffer	Yes	RXUART	Not applicable	Yes
Block Function	Register Function	DCB Only																											
Timer	Period	No																											
Counter	Period	No																											
Dead Band	Period	No																											
CRCPRS	Polynomial	No																											
SPIM	TX Buffer	Yes																											
SPIS	TX Buffer	Yes																											
TXUART	TX Buffer	Yes																											
RXUART	Not applicable	Yes																											

13.2.7 DxBxxDR2

Digital Basic/Communication Type B Block Data Register 2

Individual Register Names and Addresses:

DBB00DR2 : 0,22h	DBB01DR2 : 0,26h	DCB02DR2 : 0,2Ah	DCB03DR2 : 0,2Eh
DBB10DR2 : 0,32h	DBB11DR2 : 0,36h	DCB12DR2 : 0,3Ah	DCB13DR2 : 0,3Eh
DBB20DR2 : 0,42h	DBB21DR2 : 0,46h	DCB22DR2 : 0,4Ah	DCB23DR2 : 0,4Eh
DBB30DR2 : 0,52h	DBB31DR2 : 0,56h	DCB32DR2 : 0,5Ah	DCB33DR2 : 0,5Eh

	7	6	5	4	3	2	1	0
Access : POR	RW* : 00							
Bit Name	Data[7:0]							

This register is the data register for a digital block.

The use of this register is dependent on which function is selected for its block. This selection is made in the FN[2:0] bits of the [DxBxxFN register on page 257](#). Refer to the [DxBxxDR0 register on page 153](#) for naming convention and digital row availability information. For additional information, refer to the “[Register Definitions](#)” on [page 345](#) in the Digital Blocks chapter.

* If the block is configured as SPIM, SPIS, or RXUART, this register is read only.

Bit	Name	Description																											
7:0	Data[7:0]	Data for selected function.																											
		<table border="0"> <thead> <tr> <th>Block Function</th> <th>Register Function</th> <th>DCB Only</th> </tr> </thead> <tbody> <tr> <td>Timer</td> <td>Capture/Compare</td> <td>No</td> </tr> <tr> <td>Counter</td> <td>Compare</td> <td>No</td> </tr> <tr> <td>Dead Band</td> <td>Buffer</td> <td>No</td> </tr> <tr> <td>CRCPRS</td> <td>Seed/Residue</td> <td>No</td> </tr> <tr> <td>SPIM</td> <td>RX Buffer</td> <td>Yes</td> </tr> <tr> <td>SPIS</td> <td>RX Buffer</td> <td>Yes</td> </tr> <tr> <td>TXUART</td> <td>Not applicable</td> <td>Yes</td> </tr> <tr> <td>RXUART</td> <td>RX Buffer</td> <td>Yes</td> </tr> </tbody> </table>	Block Function	Register Function	DCB Only	Timer	Capture/Compare	No	Counter	Compare	No	Dead Band	Buffer	No	CRCPRS	Seed/Residue	No	SPIM	RX Buffer	Yes	SPIS	RX Buffer	Yes	TXUART	Not applicable	Yes	RXUART	RX Buffer	Yes
Block Function	Register Function	DCB Only																											
Timer	Capture/Compare	No																											
Counter	Compare	No																											
Dead Band	Buffer	No																											
CRCPRS	Seed/Residue	No																											
SPIM	RX Buffer	Yes																											
SPIS	RX Buffer	Yes																											
TXUART	Not applicable	Yes																											
RXUART	RX Buffer	Yes																											

0,23h

13.2.8 DxBxxCR0 (Timer Control)

Digital Basic/Communication Type B Block Control Register 0

Individual Register Names and Addresses:

DBB00CR0 : 0,23h	DBB01CR0 : 0,27h	DCB02CR0 : 0,2Bh	DCB03CR0 : 0,2Fh
DBB10CR0 : 0,33h	DBB11CR0 : 0,37h	DCB12CR0 : 0,3Bh	DCB13CR0 : 0,3Fh
DBB20CR0 : 0,43h	DBB21CR0 : 0,47h	DCB22CR0 : 0,4Bh	DCB23CR0 : 0,4Fh
DBB30CR0 : 0,53h	DBB31CR0 : 0,57h	DCB32CR0 : 0,5Bh	DCB33CR0 : 0,5Fh

	7	6	5	4	3	2	1	0
Access : POR						RW : 0	RW : 0	RW : 0
Bit Name						TC Pulse Width	Capture Int	Enable

This register is the Control register for a timer, if the [DxBxxFN](#) register is configured as a '000'.

Refer to the [DxBxxDR0](#) register on page 153 for naming convention and digital row availability information. In the table above, note that reserved bits are grayed table cells and are not described in the bit description section below. Reserved bits should always be written with a value of '0'. For additional information, refer to the "Register Definitions" on page 345 in the Digital Blocks chapter.

Bit	Name	Description
2	TC Pulse Width	Primary output 0 Terminal Count pulse width is one-half a block clock. Supports a period value of 00h. 1 Terminal Count pulse width is one full block clock.
1	Capture Int	0 Interrupt is selected with Mode bit 0 in the Function (DxBxxFN) register. 1 Block interrupt is caused by a hardware <i>capture</i> event (overrides Mode bit 0 selection).
0	Enable	0 Timer is not enabled. 1 Timer is enabled.

13.2.9 DxBxxCR0 (Counter Control)

Digital Basic/Communication Type B Block Control Register 0

Individual Register Names and Addresses:

DBB00CR0: 0,23h	DBB01CR0: 0,27h	DCB02CR0: 0,2Bh	DCB03CR0: 0,2Fh
DBB10CR0: 0,33h	DBB11CR0: 0,37h	DCB12CR0: 0,3Bh	DCB13CR0: 0,3Fh
DBB20CR0: 0,43h	DBB21CR0: 0,47h	DCB22CR0: 0,4Bh	DCB23CR0: 0,4Fh
DBB30CR0: 0,53h	DBB31CR0: 0,57h	DCB32CR0: 0,5Bh	DCB33CR0: 0,5Fh

	7	6	5	4	3	2	1	0
Access : POR								RW : 0
Bit Name								Enable

This register is the Control register for a counter, if the [DxBxxFN](#) register is configured as a '001'.

Refer to the [DxBxxDR0](#) register on page 153 for naming convention and digital row availability information. In the table above, note that reserved bits are grayed table cells and are not described in the bit description section below. Reserved bits should always be written with a value of '0'. For additional information, refer to the "Register Definitions" on page 345 in the Digital Blocks chapter.

Bit	Name	Description
0	Enable	0 Counter is not enabled. 1 Counter is enabled.

0,23h

13.2.10 DxBxxCR0 (Dead Band Control) Digital Basic/Communication Type B Block Control Register 0

Individual Register Names and Addresses:

DBB00CR0: 0,23h	DBB01CR0: 0,27h	DCB02CR0: 0,2Bh	DCB03CR0: 0,2Fh
DBB10CR0: 0,33h	DBB11CR0: 0,37h	DCB12CR0: 0,3Bh	DCB13CR0: 0,3Fh
DBB20CR0: 0,43h	DBB21CR0: 0,47h	DCB22CR0: 0,4Bh	DCB23CR0: 0,4Fh
DBB30CR0: 0,53h	DBB31CR0: 0,57h	DCB32CR0: 0,5Bh	DCB33CR0: 0,5Fh

	7	6	5	4	3	2	1	0
Access : POR						RW : 0	RW : 0	RW : 0
Bit Name						Bit Bang Clock	Bit Bang Mode	Enable

This register is the Control register for a dead band, if the [DxBxxFN](#) register is configured as a '100'.

Refer to the [DxBxxDR0](#) register on page 153 for naming convention and digital row availability information. In the table above, note that reserved bits are grayed table cells and are not described in the bit description section below. Reserved bits should always be written with a value of '0'. For additional information, refer to the "Register Definitions" on page 345 in the Digital Blocks chapter.

Bit	Name	Description
2	Bit Bang Clock	When Bit Bang mode is enabled, the output of this register bit is substituted for the PWM reference. This register may be toggled by user firmware to generate PHI1 and PH2 output clocks with the programmed dead time.
1	Bit Bang Mode	0 Dead Band Generator uses the previous block primary output as the input reference. 1 Dead Band Generator uses the Bit Bang Clock register as the input reference.
0	Enable	0 Dead Band Generator is not enabled. 1 Dead Band Generator is enabled.

13.2.11 DxBxxCR0 (CRCPRS Control)

Digital Basic/Communication Type B Block Control Register 0

Individual Register Names and Addresses:

DBB00CR0: 0,23h	DBB01CR0: 0,27h	DCB02CR0: 0,2Bh	DCB03CR0: 0,2Fh
DBB10CR0: 0,33h	DBB11CR0: 0,37h	DCB12CR0: 0,3Bh	DCB13CR0: 0,3Fh
DBB20CR0: 0,43h	DBB21CR0: 0,47h	DCB22CR0: 0,4Bh	DCB23CR0: 0,4Fh
DBB30CR0: 0,53h	DBB31CR0: 0,57h	DCB32CR0: 0,5Bh	DCB33CR0: 0,5Fh

	7	6	5	4	3	2	1	0
Access : POR							RW : 0	RW : 0
Bit Name							Pass Mode	Enable

This register is the Control register for a CRCPRS, if the [DxBxxFN](#) register is configured as a '010'.

Refer to the [DxBxxDR0](#) register on page 153 for naming convention and digital row availability information. In the table above, note that reserved bits are grayed table cells and are not described in the bit description section below. Reserved bits should always be written with a value of '0'. For additional information, refer to the "Register Definitions" on page 345 in the Digital Blocks chapter.

Bit	Name	Description
1	Pass Mode	If selected, the DATA input selection is driven directly to the primary output and the block interrupt output. The CLK input selection is driven directly to the auxiliary output. 0 Normal CRC/PRS outputs. 1 Outputs are overridden.
0	Enable	0 CRC/PRS is not enabled. 1 CRC/PRS is enabled.

0,2Bh

13.2.12 DCBxxCR0 (SPIM Control)

Digital Communication Type B Block Control Register 0

Individual Register Names and Addresses:

DCB02CR0: 0,2Bh DCB22CR0: 0,4Bh DCB03CR0: 0,2Fh DCB23CR0: 0,4Fh
 DCB12CR0: 0,3Bh DCB32CR0: 0,5Bh DCB13CR0: 0,3Fh DCB33CR0: 0,5Fh

	7	6	5	4	3	2	1	0
Access : POR	RW : 0	R : 0	R : 0	R : 1	R : 0	RW : 0	RW : 0	RW : 0
Bit Name	LSb First	Overrun	SPI Complete	TX Reg Empty	RX Reg Full	Clock Phase	Clock Polarity	Enable

This register is the Control register for a SPIM, if the [DxBxxFN](#) register is configured as a '110'.

The LSb First, Clock Phase, and Clock Polarity bits are configuration bits and should never be changed once the block is enabled. They can be set at the same time that the block is enabled. Refer to the [DxBxxDR0](#) register on page 153 for naming convention and digital row availability information. For additional information, refer to the "Register Definitions" on page 345 in the Digital Blocks chapter.

Bit	Name	Description
7	LSb First	This bit should not be changed during an SPI transfer. 0 Data is shifted out MSb first. 1 Data is shifted out LSb first.
6	Overrun	0 No overrun has occurred. 1 Overrun has occurred. Indicates that a new byte is received and loaded into the RX Buffer before the previous one is read. It is cleared on a read of this (CR0) register.
5	SPI Complete	0 Indicates that a byte may still be in the process of shifting out, or no transmission is active. 1 Indicates that a byte is shifted out and all associated clocks are generated. It is cleared on a read of this (CR0) register. Optional interrupt.
4	TX Reg Empty	Reset state and the state when the block is disabled is '1'. 0 Indicates that a byte is currently buffered in the TX register. 1 Indicates that a byte is written to the TX register and cleared on write of the TX Buffer (DR1) register. This is the default interrupt. This status is initially asserted on block enable; however, the TX Reg Empty interrupt will occur only after the first data byte is written and transferred into the shifter.
3	RX Reg Full	0 RX register is empty. 1 A byte is received and loaded into the RX register. It is cleared on a read of the RX Buffer (DR2) register.
2	Clock Phase	0 Data is latched on the leading clock edge. Data changes on the trailing edge (Modes 0, 1). 1 Data changes on the leading clock edge. Data is latched on the trailing edge (Modes 2, 3).
1	Clock Polarity	0 Non-inverted, clock idles low (Modes 0, 2). 1 Inverted, clock idles high (Modes 1, 3).
0	Enable	0 SPI Master is not enabled. 1 SPI Master is enabled.

13.2.13 DCBxxCR0 (SPIS Control)

Digital Communication Type B Block Control Register 0

Individual Register Names and Addresses:

DCB02CR0: 0,2Bh	DCB22CR0: 0,4Bh	DCB03CR0: 0,2Fh	DCB23CR0: 0,4Fh
DCB12CR0: 0,3Bh	DCB32CR0: 0,5Bh	DCB13CR0: 0,3Fh	DCB33CR0: 0,5Fh

	7	6	5	4	3	2	1	0
Access : POR	RW : 0	R : 0	R : 0	R : 1	R : 0	RW : 0	RW : 0	RW : 0
Bit Name	LSb First	Overrun	SPI Complete	TX Reg Empty	RX Reg Full	Clock Phase	Clock Polarity	Enable

This register is the Control register for a SPIS, if the [DxBxxFN](#) register is configured as a '110'.

The LSb First, Clock Phase, and Clock Polarity bits are configuration bits and should never be changed once the block is enabled. They can be set at the same time that the block is enabled. Refer to the [DxBxxDR0](#) register on page 153 for naming convention and digital row availability information. For additional information, refer to the "Register Definitions" on page 345 in the Digital Blocks chapter.

Bit	Name	Description
7	LSb First	This bit should not be changed during an SPI transfer. 0 Data is shifted out MSb first. 1 Data is shifted out LSb first.
6	Overrun	0 No overrun has occurred. 1 Overrun has occurred. Indicates that a new byte is received and loaded into the RX Buffer before the previous one is read. It is cleared on a read of this (CR0) register.
5	SPI Complete	0 Indicates that a byte may still be in the process of shifting out, or no transmission is active. 1 Indicates that a byte is shifted out and all associated clocks are generated. It is cleared on a read of this (CR0) register. Optional interrupt.
4	TX Reg Empty	Reset state and the state when the block is disabled is '1'. 0 Indicates that a byte is currently buffered in the TX register. 1 Indicates that a byte is written to the TX register and cleared on write of the TX Buffer (DR1) register. This is the default interrupt. This status is initially asserted on block enable; however, the TX Reg Empty interrupt will occur only after the first data byte is written and transferred into the shifter.
3	RX Reg Full	0 RX register is empty. 1 A byte is received and loaded into the RX register. It is cleared on a read of the RX Buffer (DR2) register.
2	Clock Phase	0 Data is latched on the leading clock edge. Data changes on the trailing edge (Modes 0, 1). 1 Data changes on the leading clock edge. Data is latched on the trailing edge (Modes 2, 3).
1	Clock Polarity	0 Non-inverted, clock idles low (Modes 0, 2). 1 Inverted, clock idles high (Modes 1, 3).
0	Enable	0 SPI Slave is not enabled. 1 SPI Slave is enabled.

0,2Bh

13.2.14 DCBxxCR0 (UART Transmitter Control)

Digital Communication Type B Block Control Register 0

Individual Register Names and Addresses:

DCB02CR0: 0,2Bh DCB22CR0: 0,4Bh DCB03CR0: 0,2Fh DCB23CR0: 0,4Fh
 DCB12CR0: 0,3Bh DCB32CR0: 0,5Bh DCB13CR0: 0,3Fh DCB33CR0: 0,5Fh

	7	6	5	4	3	2	1	0
Access : POR			R : 0	R : 1		RW : 0	RW : 0	RW : 0
Bit Name			TX Complete	TX Reg Empty		Parity Type	Parity Enable	Enable

This register is the Control register for a UART transmitter, if the [DxBxxFN](#) register is configured as a '101'.

Refer to the [DxBxxDR0](#) register on page 153 for naming convention and digital row availability information. In the table above, note that reserved bits are grayed table cells and are not described in the bit description section below. Reserved bits should always be written with a value of '0'. For additional information, refer to the "Register Definitions" on page 345 in the Digital Blocks chapter. For the Receive mode definition, refer to section 13.2.15 on page 163.

Bit	Name	Description
5	TX Complete	0 Indicates that a byte may still be in the process of shifting out. 1 Indicates that a byte is shifted out and all associated framing bits are generated. Optional interrupt. Cleared on a read of this (CR0) register.
4	TX Reg Empty	Reset state and the state when the block is disabled is '1'. 0 Indicates that a byte is currently buffered in the TX register. 1 Indicates that a byte is written to the TX register and cleared on write of the TX Buffer register. This is the default interrupt. TX Reg Empty interrupt will occur only after the first data byte is written and transferred into the shifter.
2	Parity Type	0 Even parity 1 Odd parity
1	Parity Enable	0 Parity is not enabled. 1 Parity is enabled, frame includes parity bit.
0	Enable	0 Serial Transmitter is not enabled. 1 Serial Transmitter is enabled.

13.2.15 DCBxxCR0 (UART Receiver Control)

Digital Communication Type B Block Control Register 0

Individual Register Names and Addresses:

DCB02CR0: 0,2Bh	DCB22CR0: 0,4Bh	DCB03CR0: 0,2Fh	DCB23CR0: 0,4Fh
DCB12CR0: 0,3Bh	DCB32CR0: 0,5Bh	DCB13CR0: 0,3Fh	DCB33CR0: 0,5Fh

	7	6	5	4	3	2	1	0
Access : POR	R : 0	R : 0	R : 0	R : 0	R : 0	RW : 0	RW : 0	RW : 0
Bit Name	Parity Error	Overrun	Framing Error	RX Active	RX Reg Full	Parity Type	Parity Enable	Enable

This register is the Control register for a UART receiver, if the [DxBxxFN](#) register is configured as a '101'.

Refer to the [DxBxxDR0](#) register on page 153 for naming convention and digital row availability information. For additional information, refer to the "Register Definitions" on page 345 in the Digital Blocks chapter. For the transmit mode definition, refer to section 13.2.14 on page 162.

Bit	Name	Description	
7	Parity Error	0	Indicates that no parity error has occurred.
		1	Valid when RX Reg Full is set, indicating that a parity error has occurred in the received byte and cleared on a read of this (CR0) register.
6	Overrun	0	Indicates that no overrun has occurred.
		1	Valid when RX Reg Full is set, indicating that the byte in the RX Buffer register has not been read before the next byte is loaded. It is cleared on a read of this (CR0) register.
5	Framing Error	0	Indicates no framing error has occurred.
		1	Valid when RX Reg Full is set, indicating that a framing error has occurred (a logic 0 was sampled at the STOP bit, instead of the expected logic 1). It is cleared on a read of this (CR0) register.
4	RX Active	0	Indicates that no reception is in progress.
		1	Indicates that a reception is in progress. It is set by the detection of a START bit and cleared at the <i>sampling</i> of the STOP bit.
3	RX Reg Full	0	Indicates that the RX Buffer register is empty.
		1	Indicates that a byte is received and transferred to the RX Buffer (DR2) register. This bit is cleared when the RX Buffer register (DR2) is read by the CPU. Interrupt source.
2	Parity Type	0	Even parity
		1	Odd parity
1	Parity Enable	0	Parity is not enabled.
		1	Parity is enabled, frame includes parity bit.
0	Enable	0	Serial Receiver is not enabled.
		1	Serial Receiver is enabled.

13.2.16 PMAx_DR

PMA Channel Data Register

Individual Register Names and Addresses:

PMA0_DR : 0,40h PMA1_DR : 0,41h PMA2_DR : 0,42h PMA3_DR : 0,43h
 PMA4_DR : 0,44h PMA5_DR : 0,45h PMA6_DR : 0,46h PMA7_DR : 0,47h

	7	6	5	4	3	2	1	0
Access : POR	RW : 00							
Bit Name	Data[7:0]							

This register is used to read and write to a particular PMA channel by either the USB SIE or the M8C.

This register is only used by the CY8C24x94 and CY7C64215 PSoC devices. For additional information, refer to the “[Register Definitions](#)” on [page 529](#) in the Full-Speed USB chapter.

Bit	Name	Description
7:0	Data[7:0]	<p>For write operations, data is stored in the USB SRAM through this register.</p> <p>For read operations, data is read from the USB SRAM through these registers. Note that the read data has been pre-fetched so it may not represent the current contents of the SRAM. It was loaded immediately following the last read operation to the register (address automatically incremented) or at the last write to the corresponding PMAx_RA register.</p>

13.2.17 USB_SOF0

USB Start of Frame 0 Register

Individual Register Names and Addresses:

USB_SOF0 : 0,48h

	7	6	5	4	3	2	1	0
Access : POR	R : 00							
Bit Name	Frame Number[7:0]							

This register and the USB_SOF1 register comprise the 11-bit SOF frame number.

This register is only used by the CY8C24x94 and CY7C64215 PSoC devices. For additional information, refer to the [“Register Definitions” on page 529](#) in the Full-Speed USB chapter.

Bit	Name	Description
7:0	Frame Number[7:0]	The eight LSb of the most recently received frame number. The three MSb are held in the USB_SOF1 register.

13.2.18 USB_SOF1

USB Start of Frame 1 Register

Individual Register Names and Addresses:

USB_SOF1 : 0,49h

	7	6	5	4	3	2	1	0	
Access : POR							R : 0		
Bit Name							Frame Number[10:8]		

This register and the USB_SOF0 register comprise the 11-bit SOF frame number.

This register is only used by the CY8C24x94 and CY7C64215 PSoC devices. Reserved bits are grayed table cells and are not described in the bit description section below. Reserved bits should always be written with a value of '0'. For additional information, refer to the ["Register Definitions"](#) on page 529 in the Full-Speed USB chapter.

Bit	Name	Description
2:0	Frame Number[10:8]	The three MSb of the most recently received frame number. The eight LSb are held in the USB_SOF0 register.

13.2.19 USB_CR0

USB Control Register 0

Individual Register Names and Addresses:

USB_CR0 : 0,4Ah

	7	6	5	4	3	2	1	0
Access : POR	RW : 0							RW : 00
Bit Name	USB Enable							Device Address[6:0]

This register is used to set the PSoC's USB address and enable the USB system resource. This register is automatically cleared when a USB bus reset condition is detected.

This register is only used by the CY8C24x94 and CY7C64215 PSoC devices. Reserved bits are grayed table cells and are not described in the bit description section below. Reserved bits should always be written with a value of '0'. For additional information, refer to the "Register Definitions" on page 529 in the Full-Speed USB chapter.

Bit	Name	Description
7	USB Enable	This bit enables the PSoC device to respond to USB traffic. 0 USB disabled. Device will not respond to USB traffic. 1 USB enabled and USB input receiver powers up.
6:0	Device Address[6:0]	The USB address assigned to the device by the host. This value must be programmed by firmware when assigned during enumeration. It is not set automatically by the hardware.

13.2.20 USBIO_CR0

USB IO Control Register 0

Individual Register Names and Addresses:

USBIO_CR0 : 0,4Bh

	7	6	5	4	3	2	1	0
Access : POR	RW : 0	RW : 0	RW : 0					R : 0
Bit Name	TEN	TSE0	TD					RD

This register is used for manually transmitting on the USB D+ and D- pins, or reading the differential receiver.

This register is only used by the CY8C24x94 and CY7C64215 PSoC devices. Reserved bits are grayed table cells and are not described in the bit description section below. Reserved bits should always be written with a value of '0'. For additional information, refer to the "Register Definitions" on page 529 in the Full-Speed USB chapter.

Bit	Name	Description
7	TEN	<p>USB Transmit Enable. This is used to manually transmit on the D+ and D- pins. Normally, this bit should be cleared to allow the internal SIE to drive the pins. The most common reason for manually transmitting is to force a resume state on the bus.</p> <p>0 Manual Transmission Off (TSE0 and TD have no effect).</p> <p>1 Manual Transmission Enabled (TSE0 and TD determine the state of the D+ and D- pins).</p>
6	TSE0	<p>Transmit Single-Ended Zero. SE0: both D+ and D- low. No effect if TEN=0.</p> <p>0 Do not force SE0.</p> <p>1 Force SE0 on D+ and D-.</p>
5	TD	<p>Transmit Data. Transmit a USB J or K state on the USB bus. No effect if TEN=0 or TSE0=1.</p> <p>0 Force USB K state (D+ is low, D- is high).</p> <p>1 Force USB J state (D+ is high, D- is low).</p>
0	RD	<p>Received Data. This read only bit gives the state of the USB differential receiver. This bit reads zero unless the USB Enable bit in the USB10_CR0 register is set high.</p> <p>0 D+ < D- or D+ = D- = 0.</p> <p>1 D+ > D-.</p>

13.2.21 USBIO_CR1

USB IO Control Register 1

Individual Register Names and Addresses:

USBIO_CR1 : 0,4Ch

	7	6	5	4	3	2	1	0
Access : POR	RW : 0	RW : 0	RW : 0	RW : 0	RW : 0	RW : 0	R : X	R : X
Bit Name	IOMode	Drive Mode	DPI	DMI	PS2PUEN	USBPUEN	DPO	DMO

This register is used to manually read or write the D+ and D- pins, and to configure them for bit banging and applying internal pull-up resistors.

This register is only used by the CY8C24x94 and CY7C64215 PSoC devices. For additional information, refer to the “[Register Definitions](#)” on page 529 in the Full-Speed USB chapter.

Bit	Name	Description
7	IOMode	USB versus IO Mode. This bit should remain cleared for USB operation. 0 USB Mode. Drive Mode has no effect. 1 Bit Bang Mode. Drive Mode, DMI and DPI determine state of the D+ and D- pins.
6	Drive Mode	If IOMode is set: 0 D+ and D- are in open drain mode. If the DPI or DMI bits are set high, the corresponding D+ or D- pad will be high impedance. 1 D+ and D- are in CMOS drive mode. D+ follows DPI and D- follows DMI.
5	DPI	Manual drive output for the D+ pad. No effect if IOMode=0. Refer to the Drive Mode bit for drive state of pad. 0 Drive D+ pad low. 1 Drive D+ pad high (unless Drive Mode=0).
4	DMI	Manual drive output for the D- pad. No effect if IOMode=0. Refer to the Drive Mode bit for drive state of pad. 0 Drive D- pad low. 1 Drive D- pad high (unless Drive Mode=0).
3	PS2PUEN	PS/2 Pull Up Enable. 0 No effect. 1 Apply 5K pull-ups between Vdd and both D+ and D- pads, independent of the IOMode and Drive Mode bits.
2	USBPUEN	USB Pull Up Enable. Note that the USB transmitter has been optimized for use with this internal pull up. Use of an external pull up on D+ is not recommended. 0 No effect. 1 Apply internal USB pull-up resistor to D+ pad.
1	DPO	Read only state of the D+ pin. 0 D+ pin is low. 1 D+ pin is high.
0	DMO	Read only state of the D- pin. 0 D- pin is low. 1 D- pin is high.

13.2.22 EPx_CNT1

Endpoint Count Register 1

Individual Register Names and Addresses:

EP1_CNT1 : 0,4Eh

EP2_CNT1 : 0,50h

EP3_CNT1 : 0,52h

EP4_CNT1 : 0,54h

	7	6	5	4	3	2	1	0
Access : POR	RW : 0	R : 0						RW : 0
Bit Name	Data Toggle	Data Valid						Count MSb

This register is used for configuring endpoints one through four.

This register is only used by the CY8C24x94 and CY7C64215 PSoC devices. Reserved bits are grayed table cells and are not described in the bit description section below. Reserved bits should always be written with a value of '0'. For additional information, refer to the ["Register Definitions" on page 529](#) in the Full-Speed USB chapter.

Bit	Name	Description
7	Data Toggle	The Data Toggle state for USB data. For IN transactions, firmware sets this bit to the appropriate data toggle state. For OUT transactions, the SIE sets this bit to the received data toggle state. 0 DATA0 1 DATA1
6	Data Valid	This bit indicates whether there were errors during OUT transactions. 0 No errors. 1 Error in CRC, bit stuff, or PID.
0	Count MSb	This bit is the MSb of the 9-bit counter formed with the value of the EPx_CNT register. Refer to the EPx_CNT register on page 171 .

13.2.23 EPx_CNT

Endpoint Count Register

Individual Register Names and Addresses:

EP1_CNT : 0,4Fh EP2_CNT : 0,51h EP3_CNT : 0,53h EP4_CNT : 0,55h

	7	6	5	4	3	2	1	0
Access : POR	RW : 00							
Bit Name	EPx Count[7:0]							

This register is used to set or report the number of bytes in a USB data transfer to the non-control endpoints.

This register is only used by the CY8C24x94 and CY7C64215 PSoC devices. For additional information, refer to the [“Register Definitions” on page 529](#) in the Full-Speed USB chapter.

Bit	Name	Description
7:0	EPx Count[7:0]	<p>The 8 LSb of a 9-bit counter; the Count MSb of the EPx_CR register is the MSb.</p> <p>For IN transactions, firmware loads the count with the number of bytes to be transmitted. Valid values are 0 to 256.</p> <p>For OUT transactions, firmware first loads the count with the maximum number of bytes to be received into the USB SRAM. Valid values are 0x00 for 1 byte through 0xFF for 256 bytes. The count is updated by hardware to the number of data bytes received, plus 2 for the CRC bytes. The CRC bytes are not stored in the USB SRAM, unless the firmware-specified count allows space for them. To get the actual number of bytes received, firmware should decrement the 9-bit count by 2.</p>

13.2.24 EPO_CR

Endpoint 0 Control Register

Individual Register Names and Addresses:

EPO_CR : 0,56h

	7	6	5	4	3	2	1	0
Access : POR	RC : 0	RC : 0	RC : 0	RC : 0	RW : 00			
Bit Name	Setup Received	IN Received	OUT Received	ACK'd Transaction	Mode[3:0]			

This register is used to configure endpoint 0.

Because both firmware and the SIE are allowed to write to the Endpoint 0 Control and Count registers, the SIE provides an interlocking mechanism to prevent accidental overwriting of data. When the SIE writes to these registers they are locked and the processor cannot write to them until after reading them. Writing to this register clears the upper four bits regardless of the value written. “Non-locked writes” in the bit descriptions below mean that the register has been read since it was locked by the SIE, so that it is no longer in the locked state.

This register is only used by the CY8C24x94 and CY7C64215 PSoC devices. For additional information, refer to the “[Register Definitions](#)” on [page 529](#) in the Full-Speed USB chapter.

Bit	Name	Description
7	Setup Received	<p>This bit is set by hardware when a valid SETUP packet is received. It is forced HIGH from the start of the data packet phase of the SETUP transactions until the end of the data phase of a control write transfer and cannot be cleared during this interval. While this bit is set to ‘1’, the CPU cannot write to the EP0_DRx registers. This prevents firmware from overwriting an incoming SETUP transaction before firmware has a chance to read the SETUP data. This bit is cleared by any non-locked writes to the register.</p> <p>0 No SETUP received 1 SETUP received</p>
6	IN Received	<p>When set, this bit indicates a valid IN packet has been received. This bit is updated to ‘1’ after the host acknowledges an IN data packet. When clear, it indicates either no IN has been received or that the host did not acknowledge the IN data by sending ACK handshake. This bit is cleared by any non-locked writes to the register.</p> <p>0 No IN received 1 IN received</p>
5	OUT Received	<p>When set, this bit indicates a valid OUT packet has been received and ACKed. This bit is updated to ‘1’ after the last received packet in an OUT transaction. When clear, it indicates no OUT received. This bit is cleared by any non-locked writes to the register.</p> <p>0 No OUT received 1 OUT received</p>
4	ACK'd Transaction	<p>The ACK'd transaction bit is set whenever the SIE engages in a transaction to the register's endpoint that completes with a ACK packet. This bit is cleared by any non-locked writes to the register</p> <p>0 The transaction does not complete with an ACK. 1 The transaction completes with an ACK.</p>
3:0	Mode[3:0]	<p>The mode controls how the USB SIE responds to traffic and how the USB SIE will change the mode of that endpoint as a result of host packets to the endpoint. Refer to the table titled “Mode Encoding for Control and Non-Control Endpoints” on page 524.</p>

13.2.25 EP0_CNT

Endpoint 0 Count Register

Individual Register Names and Addresses:

EP0_CNT : 0,57h

	7	6	5	4	3	2	1	0
Access : POR	RW : 0	RC : 0				RW : 00		
Bit Name	Data Toggle	Data Valid				Byte Count[3:0]		

This register is used to configure endpoint 0.

Whenever the count updates from a SETUP or OUT transaction, this register locks and can not be written by the CPU. Reading the EP0_CR register unlocks this register. This prevents firmware from overwriting a status update on incoming SETUP or OUT transactions before firmware has a chance to read the data.

This register is only used by the CY8C24x94 and CY7C64215 PSoC devices. Reserved bits are grayed table cells and are not described in the bit description section below. Reserved bits should always be written with a value of '0'. For additional information, refer to the ["Register Definitions"](#) on page 529 in the Full-Speed USB chapter.

Bit	Name	Description
7	Data Toggle	The Data Toggle state for USB data. For IN transactions, firmware sets this bit to the appropriate data toggle state. For OUT or SETUP transactions, the SIE sets this bit to the received data toggle state. 0 DATA0 1 DATA1
6	Data Valid	This bit indicates whether there were errors in OUT or SETUP transactions. 0 No errors. 1 Error in CRC, bit stuff, or PID.
3:0	Byte Count[3:0]	These bits indicate the number of data bytes in a transaction. For IN transactions, firmware loads the count with the number of bytes to be transmitted to the host from the endpoint FIFO. Valid values are 0 to 8. For OUT or SETUP transactions, the count is updated by hardware to the number of data bytes received, plus two for the CRC bytes. Valid values are 2 to 10.

13.2.26 EPO_DRx

Endpoint 0 Data Register

Individual Register Names and Addresses:

EPO_DR0 : 0,58h EPO_DR1 : 0,59h EPO_DR2 : 0,5Ah EPO_DR3 : 0,5Bh
 EPO_DR4 : 0,5Ch EPO_DR5 : 0,5Dh EPO_DR6 : 0,5Eh EPO_DR7 : 0,5Fh

	7	6	5	4	3	2	1	0
Access : POR	RW : 00							
Bit Name	Data Byte[7:0]							

These registers are used to read and write data bits to the USB control endpoint.

These registers have a locking feature that prevents CPU writes during an incoming SETUP packet. Once the SETUP token is decoded, these registers are locked from any CPU writes. They remain locked until the end of the packet, and then the CPU must read the EPO_CR register before these registers can be written. This is to prevent over-writing new SETUP data before firmware knows it has arrived.

These registers are only used by the CY8C24x94 and CY7C64215 PSoC devices. For additional information, refer to the “Register Definitions” on page 529 in the Full-Speed USB chapter.

Bit	Name	Description
7:0	Data Byte[7:0]	Write or read data for the control endpoint 0.

13.2.27 AMX_IN

Analog Input Select Register

Individual Register Names and Addresses:

AMX_IN: 0,60h

4 COLUMN	7	6	5	4	3	2	1	0
Access : POR	RW : 0		RW : 0		RW : 0		RW : 0	
Bit Name	ACI3[1:0]		ACI2[1:0]		ACI1[1:0]		ACI0[1:0]	

2, 1 COLUMN	7	6	5	4	3	2	1	0
Access : POR					RW : 0		RW : 0	
Bit Name					ACI1[1:0]		ACI0[1:0]	

2L* Column	7	6	5	4	3	2	1	0
Access : POR					RW : 0		RW : 0	
Bit Name					ACI1[1:0]		ACI0[1:0]	

* This table shows the two column limited functionality of the CY8C21x34, CY8C21x23, CY7C603xx, and CYWUSB6953 PSoC devices for this register.

This register controls the analog muxes that feed signals in from port pins into the analog column.

Use the register tables above, in addition to the detailed register bit descriptions below, to determine which bits are reserved for some smaller PSoC devices. (To determine how many analog columns are in your PSoC device, see the table titled "PSoC Device Characteristics" on page 371.) Note that reserved bits are grayed table cells and are not described in the bit description section below. Reserved bits should always be written with a value of '0'. For additional information, refer to the "Register Definitions" on page 408 in the Analog Input Configuration chapter.

Bits	Name	Description
7:6	ACI3[1:0]	Selects the Analog Column Mux 3. 00b ACM3 P0[0] 01b ACM3 P0[2] 10b ACM3 P0[4] 11b ACM3 P0[6]
5:4	ACI2[1:0]	Selects the Analog Column Mux 2. 00b ACM2 P0[1] 01b ACM2 P0[3] 10b ACM2 P0[5] 11b ACM2 P0[7] Note ACol2Mux (ABF_CR0, Address 1,62h) 0 AC2 = ACM2 1 AC2 = ACM3
3:2	ACI1[1:0]	Selects the Analog Column Mux 1. For 1 column, these are even inputs. 00b ACM1 P0[0] 01b ACM1 P0[2] 10b ACM1 P0[4] 11b ACM1 P0[6] Note ACol1Mux (ABF_CR0, Address 1,62h) 0 AC1 = ACM1 1 AC1 = ACM0

(continued on next page)

13.2.27 AMX_IN (continued)

1:0	ACI0[1:0]	Selects the Analog Column Mux 0. For 1 column, these are odd inputs.
	00b	ACM0 P0[1]
	01b	ACM0 P0[3]
	10b	ACM0 P0[5]
	11b	ACM0 P0[7]

13.2.28 AMUX_CFG

Analog Mux Configuration Register

Individual Register Names and Addresses:

AMUX_CFG : 0,61h

	7	6	5	4	3	2	1	0
Access : POR	RW : 0	RW : 0	RW : 0		RW : 0		RW : 0	
Bit Name	BCol1Mux	ACol0Mux	INTCAP[1:0]		MUXCLK[2:0]		EN	

This register is used to configure the clocked pre-charge mode of the analog multiplexer system.

This register is only used by the CY8C24x94, CY8C21x34, CY7C64215, CY7C603xx, and CYWUSB6953 PSoC devices. For additional information, refer to the “Register Definitions” on page 521.

Bits	Name	Description
7	BCol1Mux	<p>This bit is only available in the CY8C24x94 and CY7C64215 PSoC devices.</p> <p>0 Set column 1 input to column mux output. (selects among Port 0 pins.</p> <p>1 Set column 1 input to the analog mux bus. If the bus is configured as two nets, the analog mux bus right net connects to column 1.</p>
6	ACol0Mux	<p>This bit is only available in the CY8C24x94 and CY7C64215 PSoC devices.</p> <p>0 Set column 0 input to column 0 mux output. (selects among P0[7,5,3,1]).</p> <p>1 Set column 0 input to the analog mux bus.</p>
5:4	INTCAP[1:0]	<p>Selects pins for static operation, even when the precharge clock is selected with MUXCLK[2:0].</p> <p>The CY8C21x34, CY7C603xx, and CYWUSB6953 use pins P0[3] and P0[1] for this function.</p> <p>00b Both P0[3] and P0[1] are in normal precharge configuration.</p> <p>01b P0[1] pin selected for static mode only.</p> <p>10b P0[3] pin selected for static mode only.</p> <p>11b Both P0[3] and P0[1] are selected for static mode only.</p> <p>The CY8C24x94 and CY7C64215 uses pins P0[7] (connects to Mux Bus Right) and P0[5] (connects to Mux Bus Left) for this function.</p> <p>00b Both P0[7] and P0[5] are in normal precharge configuration.</p> <p>01b P0[5] pin selected for static mode only.</p> <p>10b P0[7] pin selected for static mode only.</p> <p>11b Both P0[7] and P0[5] are selected for static mode only.</p>
3:1	MUXCLK[2:0]	<p>Selects a precharge clock source for analog mux bus connections:</p> <p>000b Precharge clock is off, no switching.</p> <p>001b VC1</p> <p>010b VC2</p> <p>011b Row0 Broadcast</p> <p>100b Analog column clock 0</p> <p>101b Analog column clock 1</p> <p>110b Reserved</p> <p>111b Reserved</p> <p>* In the CY8C24x94 and CY7C64215 PSoC devices, the analog column clock selection is a 1x version of the clock, such as before the divide by four.</p>
0	EN	<p>0 Disable MUXCLK output</p> <p>1 Enable MUXCLK output</p>

13.2.29 PWM_CR

ADC PWM Control Register

Individual Register Names and Addresses:

PWM_CR: 0,62h

2L COLUMN	7	6	5	4	3	2	1	0
Access : POR				RW : 0		RW : 0		RW : 0
Bit Name				HIGH[2:0]		LOW[1:0]		PWMEN

This register controls the parameters for the dedicated ADC PWM. This PWM signal can be selected to gate one or more comparator bus signals (as enabled by bits 7:4 of the DEL_CR0 register).

This register is only used by the CY8C21x34, CY8C21x23, CY7C603xx, and CYWUSB6953 PSoC devices. In the table above, note that reserved bits are grayed table cells and are not described in the bit description section below. Reserved bits should always be written with a value of '0'. For additional information, refer to the "Register Definitions" on page 443 in the Two Column Limited Analog System chapter.

When the HIGH[2:0] bits are configured with a value other than zero, this PWM source overrides the digital block sources for gating as defined by ICLKS3, ICLKS2, ICLKS1, and ICLKS0 in the DEC_CR0 and DEC_CR1 registers.

Bits	Name	Description
5:3	HIGH[2:0]	000b The dedicated PWM is not in use. The gating signal reverts to a digital block output as selected by the ICLKS bits in the DEC_CR0 and DEC_CR1 registers. 001b High time is 1 VC3 period. 010b High time is 2 VC3 periods. 011b High time is 4 VC3 periods. 100b High time is 8 VC3 periods. 101b High time is 16 VC3 periods. 110b Reserved 111b Reserved
2:1	LOW[1:0]	00b No PWM low time, only the terminal count is generated. 01b Low time is 1 VC3 period. 10b Low time is 2 VC3 periods. 11b Low time is 3 VC3 periods.
0	PWMEN	0 Disable the dedicated PWM. 1 Enable the dedicated PWM.

13.2.30 ARF_CR

Analog Reference Control Register

Individual Register Names and Addresses:

ARF_CR: 0,63h

	7	6	5	4	3	2	1	0
Access : POR		RW : 0		RW : 0			RW : 0	
Bit Name		HBE		REF[2:0]			PWR[2:0]	

This register is used to configure various features of the configurable analog references.

This register is not available for the CY8C21x34, CY8C21x23, CY7C603xx, and CYWUSB6953 PSoC devices. In the table above, note that the reserved bit is a gray table cell and is not described in the bit description section below. Reserved bits should always be written with a value of '0'. For additional information, refer to the “Register Definitions” on page 412 in the Analog Reference chapter.

Bits	Name	Description																																																				
6	HBE	Bias level control for opamps. 0 Low bias mode for analog array 1 High bias mode for analog array																																																				
5:3	REF[2:0]	Analog Array Reference Control (values with respect to Vss). These three bits select the sources for analog ground (AGND), the high reference (RefHi), and the low reference (RefLo). The following table applies to 4 and 2 column PSoC devices: <table border="1" style="margin-left: 20px;"> <thead> <tr> <th></th> <th>AGND</th> <th>RefHi</th> <th>RefLo</th> </tr> </thead> <tbody> <tr> <td>000b</td> <td>Vdd/2</td> <td>Vdd/2 + Bandgap</td> <td>Vdd/2 - Bandgap</td> </tr> <tr> <td>001b</td> <td>P2[4]</td> <td>P2[4] + P2[6]</td> <td>P2[4] - P2[6]</td> </tr> <tr> <td>010b</td> <td>Vdd/2</td> <td>Vdd/2 + Vdd/2</td> <td>Vdd/2 - Vdd/2</td> </tr> <tr> <td>011b</td> <td>2 x Bandgap</td> <td>2 x Bandgap + Bandgap</td> <td>2 x Bandgap - Bandgap</td> </tr> <tr> <td>100b</td> <td>2 x Bandgap</td> <td>2 x Bandgap + P2[6]</td> <td>2 x Bandgap - P2[6]</td> </tr> <tr> <td>101b</td> <td>P2[4]</td> <td>P2[4] + Bandgap</td> <td>P2[4] - Bandgap</td> </tr> <tr> <td>110b</td> <td>Bandgap</td> <td>Bandgap + Bandgap</td> <td>Bandgap - Bandgap</td> </tr> <tr> <td>111b</td> <td>1.6 x Bandgap</td> <td>1.6 x Bandgap + 1.6 x Bandgap</td> <td>1.6 x Bandgap - 1.6 x Bandgap</td> </tr> </tbody> </table> The following table applies to a 1 column PSoC device: <table border="1" style="margin-left: 20px;"> <tbody> <tr> <td>000b</td> <td>Invalid Reference</td> </tr> <tr> <td>001b</td> <td>Invalid Reference</td> </tr> <tr> <td>010b</td> <td>Valid Reference: AGND = Vdd/2, RefHi = Vdd, RefLo = Vss.</td> </tr> <tr> <td>011b</td> <td>Invalid Reference</td> </tr> <tr> <td>100b</td> <td>Invalid Reference</td> </tr> <tr> <td>101b</td> <td>Invalid Reference</td> </tr> <tr> <td>110b</td> <td>Invalid Reference</td> </tr> <tr> <td>111b</td> <td>Invalid Reference</td> </tr> </tbody> </table>		AGND	RefHi	RefLo	000b	Vdd/2	Vdd/2 + Bandgap	Vdd/2 - Bandgap	001b	P2[4]	P2[4] + P2[6]	P2[4] - P2[6]	010b	Vdd/2	Vdd/2 + Vdd/2	Vdd/2 - Vdd/2	011b	2 x Bandgap	2 x Bandgap + Bandgap	2 x Bandgap - Bandgap	100b	2 x Bandgap	2 x Bandgap + P2[6]	2 x Bandgap - P2[6]	101b	P2[4]	P2[4] + Bandgap	P2[4] - Bandgap	110b	Bandgap	Bandgap + Bandgap	Bandgap - Bandgap	111b	1.6 x Bandgap	1.6 x Bandgap + 1.6 x Bandgap	1.6 x Bandgap - 1.6 x Bandgap	000b	Invalid Reference	001b	Invalid Reference	010b	Valid Reference: AGND = Vdd/2, RefHi = Vdd, RefLo = Vss.	011b	Invalid Reference	100b	Invalid Reference	101b	Invalid Reference	110b	Invalid Reference	111b	Invalid Reference
	AGND	RefHi	RefLo																																																			
000b	Vdd/2	Vdd/2 + Bandgap	Vdd/2 - Bandgap																																																			
001b	P2[4]	P2[4] + P2[6]	P2[4] - P2[6]																																																			
010b	Vdd/2	Vdd/2 + Vdd/2	Vdd/2 - Vdd/2																																																			
011b	2 x Bandgap	2 x Bandgap + Bandgap	2 x Bandgap - Bandgap																																																			
100b	2 x Bandgap	2 x Bandgap + P2[6]	2 x Bandgap - P2[6]																																																			
101b	P2[4]	P2[4] + Bandgap	P2[4] - Bandgap																																																			
110b	Bandgap	Bandgap + Bandgap	Bandgap - Bandgap																																																			
111b	1.6 x Bandgap	1.6 x Bandgap + 1.6 x Bandgap	1.6 x Bandgap - 1.6 x Bandgap																																																			
000b	Invalid Reference																																																					
001b	Invalid Reference																																																					
010b	Valid Reference: AGND = Vdd/2, RefHi = Vdd, RefLo = Vss.																																																					
011b	Invalid Reference																																																					
100b	Invalid Reference																																																					
101b	Invalid Reference																																																					
110b	Invalid Reference																																																					
111b	Invalid Reference																																																					
2:0	PWR[2:0]	Analog Array Power Control <table border="1" style="margin-left: 20px;"> <thead> <tr> <th></th> <th>Reference</th> <th>CT Block</th> <th>SC Blocks</th> </tr> </thead> <tbody> <tr> <td>000b</td> <td>Off</td> <td>Off</td> <td>Off</td> </tr> <tr> <td>001b</td> <td>Low</td> <td>On</td> <td>Off</td> </tr> <tr> <td>010b</td> <td>Medium</td> <td>On</td> <td>Off</td> </tr> <tr> <td>011b</td> <td>High</td> <td>On</td> <td>Off</td> </tr> <tr> <td>100b</td> <td>Off</td> <td>Off</td> <td>Off</td> </tr> <tr> <td>101b</td> <td>Low</td> <td>On</td> <td>On</td> </tr> <tr> <td>110b</td> <td>Medium</td> <td>On</td> <td>On</td> </tr> <tr> <td>111b</td> <td>High</td> <td>On</td> <td>On</td> </tr> </tbody> </table>		Reference	CT Block	SC Blocks	000b	Off	Off	Off	001b	Low	On	Off	010b	Medium	On	Off	011b	High	On	Off	100b	Off	Off	Off	101b	Low	On	On	110b	Medium	On	On	111b	High	On	On																
	Reference	CT Block	SC Blocks																																																			
000b	Off	Off	Off																																																			
001b	Low	On	Off																																																			
010b	Medium	On	Off																																																			
011b	High	On	Off																																																			
100b	Off	Off	Off																																																			
101b	Low	On	On																																																			
110b	Medium	On	On																																																			
111b	High	On	On																																																			

13.2.31 CMP_CR0

Analog Comparator Bus 0 Register

Individual Register Names and Addresses:

CMP_CR0: 0,64h

4 COLUMN	7	6	5	4	3	2	1	0
Access : POR	R : 0				RW : 0			
Bit Name	COMP[3:0]				AINT[3:0]			

2 COLUMN	7	6	5	4	3	2	1	0
Access : POR			R : 0				RW : 0	
Bit Name			COMP[1:0]				AINT[1:0]	

2L* Column	7	6	5	4	3	2	1	0
Access : POR			R : 0				RW : 0	
Bit Name			COMP[1:0]				AINT[1:0]	

* This table shows the two column limited functionality of the CY8C21x34, CY8C21x23, CY7C603xx, and CYWUSB6953 PSoC devices for this register.

1 COLUMN	7	6	5	4	3	2	1	0
Access : POR			R : 0				RW : 0	
Bit Name			COMP[1]				AINT[1]	

This register is used to poll the analog column comparator bits and select column interrupts.

Use the register tables above, in addition to the detailed register bit descriptions below, to determine which bits are reserved for some smaller PSoC devices. (To determine how many analog columns are in your PSoC device, see the table titled “PSoC Device Characteristics” on page 371.) Note that reserved bits are grayed table cells and are not described in the bit description section below. Reserved bits should always be written with a value of ‘0’. For additional information, refer to the “Register Definitions” on page 386 in the Analog Interface chapter.

Bits	Name	Description
7	COMP[3]	Comparator bus state for column 3. This bit is updated on the <i>rising edge</i> of PHI2, unless the <i>comparator</i> latch disable bits are set (refer to the CLDISx bits in the CMP_CR1 register). If the comparator latch disable bits are set, then this bit is transparent to the comparator bus in the analog array.
6	COMP[2]	Comparator bus state for column 2. This bit is updated on the rising edge of PHI2, unless the comparator latch disable bits are set (refer to the CLDISx bits in the CMP_CR1 register). If the comparator latch disable bits are set, then this bit is transparent to the comparator bus in the analog array.
5	COMP[1]	Comparator bus state for column 1. This bit is updated on the rising edge of PHI2, unless the comparator latch disable bits are set (refer to the CLDISx bits in the CMP_CR1 register). If the comparator latch disable bits are set, then this bit is transparent to the comparator bus in the analog array.
4	COMP[0]	Comparator bus state for column 0. This bit is updated on the rising edge of PHI2, unless the comparator latch disable bits are set (refer to the CLDISx bits in the CMP_CR1 register). If the comparator latch disable bits are set, then this bit is transparent to the comparator bus in the analog array.

(continued on next page)

13.2.31 CMP_CR0 (continued)

3	AINT[3]	Controls the selection of the analog comparator interrupt for column 3. 0 The comparator data bit from the column is the input to the interrupt controller. 1 The falling edge of PHI2 for the column is the input to the interrupt controller.
2	AINT[2]	Controls the selection of the analog comparator interrupt for column 2. 0 The comparator data bit from the column is the input to the interrupt controller. 1 The falling edge of PHI2 for the column is the input to the interrupt controller.
1	AINT[1]	Controls the selection of the analog comparator interrupt for column 1. 0 The comparator data bit from the column is the input to the interrupt controller. 1 The falling edge of PHI2 for the column is the input to the interrupt controller. In 2 column limited analog PSoC devices, this bit selects the terminal count for the dedicated incremental PWM as the interrupt source.
0	AINT[0]	Controls the selection of the analog comparator interrupt for column 0. 0 The comparator data bit from the column is the input to the interrupt controller. 1 The falling edge of PHI2 for the column is the input to the interrupt controller. In 2 column limited analog PSoC devices, this bit selects the terminal count for the dedicated incremental PWM as the interrupt source.

13.2.32 ASY_CR

Analog Synchronization Control Register

Individual Register Names and Addresses:

ASY_CR: 0,65h

4, 2 COLUMN	7	6	5	4	3	2	1	0
Access : POR			W : 0		RW : 0	RW : 0		RW : 0
Bit Name			SARCNT[2:0]		SARSIGN	SARCOL[1:0]		SYNCEN

1 COLUMN	7	6	5	4	3	2	1	0
Access : POR			W : 0		RW : 0	RW : 0		RW : 0
Bit Name			SARCNT[2:0]		SARSIGN	SARCOL[1]		SYNCEN

This register is used to control SAR operation, except for the SYNCEN bit which is associated with analog register write stalling.

Use the register tables above, in addition to the detailed register bit descriptions below, to determine which bits are reserved for some smaller PSoC devices. (To determine how many analog columns are in your PSoC device, see the table titled “PSoC Device Characteristics” on page 371.) Note that reserved bits are grayed table cells and are not described in the bit description section below. Reserved bits should always be written with a value of ‘0’. For additional information, refer to the “Register Definitions” on page 386 in the Analog Interface chapter.

Bits	Name	Description
6:4	SARCNT[2:0]	Initial SAR count. This field is initialized to the number of SAR bits to process. Note Any write to the SARCNT bits, other than ‘0’, will result in a modification of the read back of any analog register in the analog array. These bits must always be zero, except for SAR processing.
3	SARSIGN	This bit adjusts the SAR comparator based on the type of block addressed. In a DAC configuration with more than one analog block (more than 6 bits), this bit should be set to ‘0’ when processing the most significant block. It should be set to ‘1’ when processing the least significant block., because the least significant block is an inverting input to the most significant block.
2:1	SARCOL[1:0]	The selected column corresponds with the position of the SAR comparator block. Note that the comparator and DAC can be in the same block. 00b Analog Column 0 is the source for SAR comparator. 01b Analog Column 1 is the source for SAR comparator. 10b Analog Column 2 is the source for SAR comparator. 11b Analog Column 3 is the source for SAR comparator.
0	SYNCEN	Set to ‘1’, will stall the CPU until the rising edge of PHI1, if a write to a register within an analog Switch Cap block takes place. 0 CPU stalling disabled. 1 CPU stalling enabled.

13.2.33 CMP_CR1

Analog Comparator Bus 1 Register

Individual Register Names and Addresses:

CMP_CR1: 0,66h

4 COLUMN	7	6	5	4	3	2	1	0
Access : POR	RW : 0	RW : 0	RW : 0	RW : 0				
Bit Name	CLDIS[3]	CLDIS[2]	CLDIS[1]	CLDIS[0]				

2, 2L* COLUMN	7	6	5	4	3	2	1	0
Access : POR			RW : 0	RW : 0			RW : 0	RW : 0
Bit Name			CLDIS[1]	CLDIS[0]			CLK1X[1]	CLK1X[0]

* This table also shows the two column limited functionality of CY8C21x34, CY8C21x23, CY7C603xx, and CYWUSB6953 PSoC devices for this register.

1 COLUMN	7	6	5	4	3	2	1	0
Access : POR			RW : 0					
Bit Name			CLDIS[1]					

This register is used to override the analog column comparator synchronization, or select direct column clock synchronization for the CY8C24x94 and CY7C64215 PSoC devices.

By default, the analog comparator bus is synchronized by the column clock and driven to the digital comparator bus for use in the digital array and the interrupt controller. The CLDIS bits are used to bypass the synchronization. This bypass mode can be used in power down operation to wake the device out of sleep, as a result of an analog column interrupt. Most devices update the comparator bus on the rising edge of PHI2. In the case of the two column limited PSoC devices (CY8C21x34, CY8C21x23, CY7C603xx, and CYWUSB6953), 2 phase clocking is not used and therefore the comparator bus is updated to the rising edge of the selected column clock. The CY8C24x94 and CY7C64215 PSoC devices have the option to synchronize using PHI2 or, when the CLK1X bits are set for a given column, 1X rising edge column clock sync is enabled.

Use the register tables above, in addition to the detailed register bit descriptions below, to determine which bits are reserved for some smaller PSoC devices. (To determine how many analog columns are in your PSoC device, see the table titled "PSoC Device Characteristics" on page 371.) Note that reserved bits are grayed table cells and are not described in the bit description section below. Reserved bits should always be written with a value of '0'. For additional information, refer to the "Register Definitions" on page 386 in the Analog Interface chapter.

Bits	Name	Description
7	CLDIS[3]	Controls the comparator output latch, column 3. 0 Comparator bus synchronization is enabled. 1 Comparator bus synchronization is disabled.
6	CLDIS[2]	Controls the comparator output latch, column 2. 0 Comparator bus synchronization is enabled. 1 Comparator bus synchronization is disabled.
5	CLDIS[1]	Controls the comparator output latch, column 1. 0 Comparator bus synchronization is enabled. 1 Comparator bus synchronization is disabled.
4	CLDIS[0]	Controls the comparator output latch, column 0. 0 Comparator bus synchronization is enabled. 1 Comparator bus synchronization is disabled.

(continued on next page)

13.2.33 CMP_CR1 (continued)

1	CLK1X[1]	Controls the digital comparator bus 1 synchronization clock. This bit is only used by the CY8C24x94 and CY7C64215 PSoC devices. 0 Comparator bit is synchronized by rising edge of PHI2. 1 Comparator bit is synchronized directly by selected column clock. (This clock is not divided by 4.)
0	CLK1X[0]	Controls the digital comparator bus 0 synchronization clock. This bit is only used by the CY8C24x94 and CY7C64215 PSoC devices. 0 Comparator bit is synchronized by rising edge of PHI2. 1 Comparator bit is synchronized directly by selected column clock. (This clock is not divided by 4.)

13.2.34 ADCx_CR

ADC Column 0 and Column 1 Configuration Register

Individual Register Names and Addresses:

ADC0_CR : 0,68h ADC1_CR : 0,69h

	7	6	5	4	3	2	1	0
Access : POR	R : 0	RW : 0	RW : 0		RW : 0	RW : 0		RW : 0
Bit Name	CMPST	LOREN	SHEN		CBSRC	AUTO		ADCEN

This register controls the single slope ADC in each column.

This register is only used by the CY8C21x34, CY8C21x23, CY7C603xx, and CYWUSB6953 PSoC devices. ADC0_CR is the ADC column 0 configuration register and ADC1_CR is the ADC column 1 configuration register. Reserved bits are grayed table cells and are not described in the bit description section below. Reserved bits should always be written with a value of '0'. For additional information, refer to the “[Register Definitions](#)” on page 443 in the Two Column Limited Analog System chapter.

Bit	Name	Description
7	CMPST	This bit is the state of the comparator at the end of an ADC conversion period (as defined by the falling edge of the gating PWM). It is read only. 0 The comparator tripped during the previous conversion ramp. 1 The comparator did not trip during the previous conversion ramp.
6	LOREN	This bit controls an approximate 4-to-1 range on the ADC current source. 0 Normal current range 1 Low current range
5	SHEN	Sample and Hold Enable. The sample and hold function is only applicable to the PMUX (positive) comparator input. 0 Disabled 1 Enabled
3	CBSRC	Digital Comparator Bus Source. There are two possible sources for the digital comparator bus in conjunction with ADC operation. 0 Digital comparator bus is driven with synchronized and gated analog comparator output. Implements a Counter Enable interface. 1 Digital comparator bus is driven with the selected PWM terminal count. Implements a Timer Capture interface.
2	AUTO	Auto ADC Mode. The bit allows for a periodic signal to control ADC sequencing. 0 Auto mode off. 1 Auto mode on. Set this bit for ADC operation. The voltage ramp generator and sample and hold circuitry are controlled by the selected PWM signal (digital block or dedicated PWM).
0	ADCEN	Enable. Configures the ADC for operation, power up. 0 Disabled, Powered Down. 1 Enabled

13.2.35 TMP_DRx

Temporary Data Register

Individual Register Names and Addresses:

TMP_DR0 : x,6Ch TMP_DR1 : x,6Dh TMP_DR2 : x,6Eh TMP_DR3 : x,6Fh

	7	6	5	4	3	2	1	0
Access : POR	RW : 00							
Bit Name	Data[7:0]							

This register is used to enhance the performance in multiple SRAM page PSoC devices.

All bits in this register are reserved for PSoC devices with 256 bytes of SRAM. Refer to the table titled “PSoC Device SRAM Availability” on page 85. For additional information, refer to the “Register Definitions” on page 89 in the RAM Paging chapter.

Bit	Name	Description
7:0	Data[7:0]	General purpose register space.

13.2.36 ACBxxCR3

Analog Continuous Time Type B Block Control Register 3

Individual Register Names and Addresses:

ACB00CR3 : x,70h ACB01CR3 : x,74h ACB02CR3 : x,78h ACB03CR3 : x,7Ch

	7	6	5	4	3	2	1	0
Access : POR					RW : 0	RW : 0	RW : 0	RW : 0
Bit Name					LPCMPEN	CMOUT	INSAMP	EXGAIN

This register is one of four registers used to configure a type B continuous time PSoC block.

The register naming convention for arrays of PSoC blocks and their registers is <Prefix>mn<Suffix>, where m=row index, n=column index; therefore, ACB01CR3 is a register for an analog PSoC block in row 0 column 1. Depending on the analog column characteristics of your PSoC device (see the table titled “PSoC Device Characteristics” on page 371), some addresses may not be available. In the table above, note that reserved bits are grayed table cells and are not described in the bit description section below. Reserved bits should always be written with a value of ‘0’. For additional information, refer to the “Register Definitions” on page 417 in the Continuous Time Block chapter.

Bits	Name	Description	
3	LPCMPEN	0	Low power comparator is disabled.
		1	Low power comparator is enabled.
2	CMOUT	0	No connection to column output
		1	Connect Common mode to column output
1	INSAMP	0	Normal mode
		1	Connect amplifiers across column to form an Instrumentation Amp
0	EXGAIN	0	Standard Gain mode
		1	High Gain mode (see the ACBxxCR0 register on page 188)

13.2.37 ACBxxCR0

Analog Continuous Time Type B Block Control Register 0

Individual Register Names and Addresses:

ACB00CR0 : x,71h ACB01CR0 : x,75h ACB02CR0 : x,79h ACB03CR0 : x,7Dh

	7	6	5	4	3	2	1	0
Access : POR	RW : 0			RW : 0		RW : 0		RW : 0
Bit Name	RTapMux[3:0]			Gain		RTopMux		RBotMux[1:0]

This register is one of four registers used to configure a type B continuous time PSoC block.

The register naming convention for arrays of PSoC blocks and their registers is <Prefix>mn<Suffix>, where m=row index, n=column index; therefore, ACB01CR0 is a register for an analog PSoC block in row 0 column 1. Depending on the analog column characteristics of your PSoC device (see the table titled “PSoC Device Characteristics” on page 371), some addresses may not be available. For additional information, refer to the “Register Definitions” on page 417 in the Continuous Time Block chapter.

Bits	Name	Description																																																																																																																		
7:4	RTapMux[3:0]	Encoding for selecting one of 18 resistor taps. The four bits of RTapMux[3:0] allow selection of 16 taps. The two additional tap selections are provided using ACBxxCR3 bit 0, EXGAIN. The EXGAIN bit only affects the RTapMux values 0h and 1h. <table border="1" data-bbox="483 1087 1091 1591"> <thead> <tr> <th>RTap</th> <th>EXGAIN</th> <th>Rf</th> <th>Ri</th> <th>Loss</th> <th>Gain</th> </tr> </thead> <tbody> <tr><td>0h</td><td>1</td><td>47</td><td>1</td><td>0.0208</td><td>48.000</td></tr> <tr><td>1h</td><td>1</td><td>46</td><td>2</td><td>0.0417</td><td>24.000</td></tr> <tr><td>0h</td><td>0</td><td>45</td><td>3</td><td>0.0625</td><td>16.000</td></tr> <tr><td>1h</td><td>0</td><td>42</td><td>6</td><td>0.1250</td><td>8.000</td></tr> <tr><td>2h</td><td>0</td><td>39</td><td>9</td><td>0.1875</td><td>5.333</td></tr> <tr><td>3h</td><td>0</td><td>36</td><td>12</td><td>0.2500</td><td>4.000</td></tr> <tr><td>4h</td><td>0</td><td>33</td><td>15</td><td>0.3125</td><td>3.200</td></tr> <tr><td>5h</td><td>0</td><td>30</td><td>18</td><td>0.3750</td><td>2.667</td></tr> <tr><td>6h</td><td>0</td><td>27</td><td>21</td><td>0.4375</td><td>2.286</td></tr> <tr><td>7h</td><td>0</td><td>24</td><td>24</td><td>0.5000</td><td>2.000</td></tr> <tr><td>8h</td><td>0</td><td>21</td><td>27</td><td>0.5625</td><td>1.778</td></tr> <tr><td>9h</td><td>0</td><td>18</td><td>30</td><td>0.6250</td><td>1.600</td></tr> <tr><td>Ah</td><td>0</td><td>15</td><td>33</td><td>0.6875</td><td>1.455</td></tr> <tr><td>Bh</td><td>0</td><td>12</td><td>36</td><td>0.7500</td><td>1.333</td></tr> <tr><td>Ch</td><td>0</td><td>9</td><td>39</td><td>0.8125</td><td>1.231</td></tr> <tr><td>Dh</td><td>0</td><td>6</td><td>42</td><td>0.8750</td><td>1.143</td></tr> <tr><td>Eh</td><td>0</td><td>3</td><td>45</td><td>0.9375</td><td>1.067</td></tr> <tr><td>Fh</td><td>0</td><td>0</td><td>48</td><td>1.0000</td><td>1.000</td></tr> </tbody> </table>	RTap	EXGAIN	Rf	Ri	Loss	Gain	0h	1	47	1	0.0208	48.000	1h	1	46	2	0.0417	24.000	0h	0	45	3	0.0625	16.000	1h	0	42	6	0.1250	8.000	2h	0	39	9	0.1875	5.333	3h	0	36	12	0.2500	4.000	4h	0	33	15	0.3125	3.200	5h	0	30	18	0.3750	2.667	6h	0	27	21	0.4375	2.286	7h	0	24	24	0.5000	2.000	8h	0	21	27	0.5625	1.778	9h	0	18	30	0.6250	1.600	Ah	0	15	33	0.6875	1.455	Bh	0	12	36	0.7500	1.333	Ch	0	9	39	0.8125	1.231	Dh	0	6	42	0.8750	1.143	Eh	0	3	45	0.9375	1.067	Fh	0	0	48	1.0000	1.000
RTap	EXGAIN	Rf	Ri	Loss	Gain																																																																																																															
0h	1	47	1	0.0208	48.000																																																																																																															
1h	1	46	2	0.0417	24.000																																																																																																															
0h	0	45	3	0.0625	16.000																																																																																																															
1h	0	42	6	0.1250	8.000																																																																																																															
2h	0	39	9	0.1875	5.333																																																																																																															
3h	0	36	12	0.2500	4.000																																																																																																															
4h	0	33	15	0.3125	3.200																																																																																																															
5h	0	30	18	0.3750	2.667																																																																																																															
6h	0	27	21	0.4375	2.286																																																																																																															
7h	0	24	24	0.5000	2.000																																																																																																															
8h	0	21	27	0.5625	1.778																																																																																																															
9h	0	18	30	0.6250	1.600																																																																																																															
Ah	0	15	33	0.6875	1.455																																																																																																															
Bh	0	12	36	0.7500	1.333																																																																																																															
Ch	0	9	39	0.8125	1.231																																																																																																															
Dh	0	6	42	0.8750	1.143																																																																																																															
Eh	0	3	45	0.9375	1.067																																																																																																															
Fh	0	0	48	1.0000	1.000																																																																																																															
3	Gain	Select gain or loss configuration for output tap. 0 Loss 1 Gain																																																																																																																		
2	RTopMux	Encoding for feedback resistor select. 0 Rtop to Vdd 1 Rtop to opamp's output																																																																																																																		

(continued on next page)

13.2.37 ACBxxCR0 (continued)

1:0 RBotMux[1:0]

Encoding for feedback resistor select. Bits [1:0] are overridden if bit 1 of the ACBxxCR3 register is set. In that case, the bottom of the resistor string is connected across columns. Note that available mux inputs vary by individual PSoC block. In the table below, only columns ACB00 and ACB01 are used by the 2 column analog PSoC blocks and all columns are used by the 4 column analog PSoC blocks.

	ACB00	ACB01	ACB02	ACB03
00b	ACB01	ACB00	ACB03	ACB02
01b	AGND	AGND	AGND	AGND
10b	Vss	Vss	Vss	Vss
11b	ASC10	ASD11	ASC12	ASD13

The following table is used by the 1 column analog PSoC blocks.

	ACB01
00b	Reserved
01b	AGND
10b	Vss
11b	ASD11

13.2.38 ACBxxCR1

Analog Continuous Time Type B Block Control Register 1

Individual Register Names and Addresses:

ACB00CR1 : x,72h ACB01CR1 : x,76h ACB02CR1 : x,7Ah ACB03CR1 : x,7Eh

	7	6	5	4	3	2	1	0
Access : POR	RW : 0	RW : 0	RW : 0			RW : 0		
Bit Name	AnalogBus	CompBus	NMux[2:0]			PMux[2:0]		

This register is one of four registers used to configure a type B continuous time PSoC block.

The register naming convention for arrays of PSoC blocks and their registers is <Prefix>mn<Suffix>, where m=row index, n=column index; therefore, ACB01CR1 is a register for an analog PSoC block in row 0 column 1. Depending on the analog column characteristics of your PSoC device (see the table titled “PSoC Device Characteristics” on page 371), some addresses may not be available. For additional information, refer to the “Register Definitions” on page 417 in the Continuous Time Block chapter.

This register is used for all PSoC devices except the two column limited CY8C21x34, CY8C21x23, CY7C603xx, and CYWUSB6953 PSoC devices, which use Type E blocks. For two column limited PSoC devices, refer to the ACExxCR1 register following this register.

Bits	Name	Description																																																															
7	AnalogBus	Enable output to the analog bus. 0 Disable output to analog column bus. 1 Enable output to analog column bus.																																																															
6	CompBus	Enable output to the comparator bus. 0 Disable output to comparator bus. 1 Enable output to comparator bus.																																																															
5:3	NMux[2:0]	Encoding for negative input select. Note that available mux inputs vary by individual PSoC block. In the table below, only columns ACB00 and ACB01 are used by the 2 column analog PSoC blocks and all columns are used by the 4 column analog PSoC blocks. <table border="1"> <thead> <tr> <th></th> <th>ACB00</th> <th>ACB01</th> <th>ACB02</th> <th>ACB03</th> </tr> </thead> <tbody> <tr> <td>000b</td> <td>ACB01</td> <td>ACB00</td> <td>ACB03</td> <td>ACB02</td> </tr> <tr> <td>001b</td> <td>AGND</td> <td>AGND</td> <td>AGND</td> <td>AGND</td> </tr> <tr> <td>010b</td> <td>RefLo</td> <td>RefLo</td> <td>RefLo</td> <td>RefLo</td> </tr> <tr> <td>011b</td> <td>RefHi</td> <td>RefHi</td> <td>RefHi</td> <td>RefHi</td> </tr> <tr> <td>100b</td> <td>FB[#]</td> <td>FB[#]</td> <td>FB[#]</td> <td>FB[#]</td> </tr> <tr> <td>101b</td> <td>ASC10</td> <td>ASD11</td> <td>ASC12</td> <td>ASD13</td> </tr> <tr> <td>110b</td> <td>ASD11</td> <td>ASC10</td> <td>ASD13</td> <td>ASC12</td> </tr> <tr> <td>111b</td> <td>Port Inputs</td> <td>Port Inputs</td> <td>Port Inputs</td> <td>Port Inputs</td> </tr> </tbody> </table> The following table is used by the 1 column analog PSoC blocks. <table border="1"> <thead> <tr> <th></th> <th>ACB01</th> </tr> </thead> <tbody> <tr> <td>000b</td> <td>Reserved</td> </tr> <tr> <td>001b</td> <td>AGND</td> </tr> <tr> <td>010b</td> <td>Vss</td> </tr> <tr> <td>011b</td> <td>Vdd</td> </tr> <tr> <td>100b</td> <td>FB[#]</td> </tr> <tr> <td>101b</td> <td>ASD11</td> </tr> <tr> <td>110b</td> <td>Reserved</td> </tr> <tr> <td>111b</td> <td>Port Inputs</td> </tr> </tbody> </table>		ACB00	ACB01	ACB02	ACB03	000b	ACB01	ACB00	ACB03	ACB02	001b	AGND	AGND	AGND	AGND	010b	RefLo	RefLo	RefLo	RefLo	011b	RefHi	RefHi	RefHi	RefHi	100b	FB [#]	FB [#]	FB [#]	FB [#]	101b	ASC10	ASD11	ASC12	ASD13	110b	ASD11	ASC10	ASD13	ASC12	111b	Port Inputs	Port Inputs	Port Inputs	Port Inputs		ACB01	000b	Reserved	001b	AGND	010b	Vss	011b	Vdd	100b	FB [#]	101b	ASD11	110b	Reserved	111b	Port Inputs
	ACB00	ACB01	ACB02	ACB03																																																													
000b	ACB01	ACB00	ACB03	ACB02																																																													
001b	AGND	AGND	AGND	AGND																																																													
010b	RefLo	RefLo	RefLo	RefLo																																																													
011b	RefHi	RefHi	RefHi	RefHi																																																													
100b	FB [#]	FB [#]	FB [#]	FB [#]																																																													
101b	ASC10	ASD11	ASC12	ASD13																																																													
110b	ASD11	ASC10	ASD13	ASC12																																																													
111b	Port Inputs	Port Inputs	Port Inputs	Port Inputs																																																													
	ACB01																																																																
000b	Reserved																																																																
001b	AGND																																																																
010b	Vss																																																																
011b	Vdd																																																																
100b	FB [#]																																																																
101b	ASD11																																																																
110b	Reserved																																																																
111b	Port Inputs																																																																

[#] Feedback point from tap of the feedback resistor as defined by corresponding CR0 bits [7:4] and CR3 bit 0.

(continued on next page)

13.2.38 ACBxxCR1 (continued)

2:0 PMux[2:0]

Encoding for positive input select. Note that available mux inputs vary by individual PSoC block.

The following table is used by the 4 column analog PSoC blocks.

	ACB00	ACB01	ACB02	ACB03
000b	RefLo	ACB02	ACB01	RefLo
001b	Port Inputs	Port Inputs	Port Inputs	Port Inputs
010b	ACB01	ACB00	ACB03	ACB02
011b	AGND	AGND	AGND	AGND
100b	ASC10	ASD11	ASC12	ASD13
101b	ASD11	ASC10	ASD13	ASC12
110b	ABUS0	ABUS1	ABUS2	ABUS3
111b	FB [#]	FB [#]	FB [#]	FB [#]

The following table is used by the 2 column analog PSoC blocks.

	ACB00	ACB01
000b	RefLo	Vss
001b	Port Inputs	Port Inputs
010b	ACB01	ACB00
011b	AGND	AGND
100b	ASC10	ASD11
101b	ASD11	ASC10
110b	ABUS0	ABUS1
111b	FB [#]	FB [#]

The following table is used by the 1 column analog PSoC blocks.

	ACB01
000b	Vss
001b	Port Inputs
010b	Reserved
011b	AGND
100b	ASD11
101b	Reserved
110b	ABUS1
111b	FB [#]

Feedback point from tap of the feedback resistor as defined by corresponding CR0 bits [7:4] and CR3 bit 0.

13.2.39 ACExxCR1

Analog Continuous Time Type E Block Control Register 1 (Dual Purpose Address, see “Mapping Exceptions” on page 141)

Individual Register Names and Addresses:

ACE00CR1 : x,72h ACE01CR1 : x,76h

2L COLUMN	7	6	5	4	3	2	1	0
Access : POR		RW : 0		RW : 0			RW : 0	
Bit Name		CompBus		NMux[2:0]			PMux[2:0]	

This register is one of two registers used to configure the type E continuous time PSoC block.

This register is only used by the CY8C21x34, CY8C21x23, CY7C603xx, and CYWUSB6953 PSoC devices. The register naming convention for arrays of PSoC blocks and their registers is <Prefix>mn<Suffix>, where m=row index, n=column index; therefore, ACE01CR1 is a register for an analog PSoC block in row 0 column 1. Depending on the analog column configuration of your PSoC device (see the table titled “PSoC Device Characteristics” on page 371), some addresses may not be available.

In the table above, note that reserved bits are grayed table cells and are not described in the bit description section below. Reserved bits should always be written with a value of ‘0’. For additional information, refer to the “Register Definitions” on page 443 in the [Two Column Limited Analog System](#) chapter on page 431.

Bits	Name	Description																																				
6	CompBus	Enable output to the comparator bus. The comparator bus is always driven from the CT block. 0 Disable output to comparator bus. 1 Enable output to comparator bus.																																				
5:3	NMux[2:0]	Encoding for negative input select. Note that available mux inputs vary by individual PSoC block. <table border="0"> <thead> <tr> <th></th> <th>ACE00</th> <th>ACE01</th> <th></th> </tr> </thead> <tbody> <tr> <td>000b</td> <td>ACE01</td> <td>ACE00</td> <td></td> </tr> <tr> <td>001b</td> <td>VBG</td> <td>VBG</td> <td></td> </tr> <tr> <td>010b</td> <td>Switch 5 & 7</td> <td>Switch 5 & 7</td> <td></td> </tr> <tr> <td>011b</td> <td>Mux Bus</td> <td>Mux Bus</td> <td>For the CY8C21x34, CY7C603xx, and CYWUSB6953 only: Chip-wide analog mux bus.</td> </tr> <tr> <td>100b</td> <td>FB#</td> <td>FB#</td> <td></td> </tr> <tr> <td>101b</td> <td>ASE10</td> <td>ASE11</td> <td></td> </tr> <tr> <td>110b</td> <td>ASE11</td> <td>ASE10</td> <td></td> </tr> <tr> <td>111b</td> <td>Port Inputs</td> <td>Port Inputs</td> <td></td> </tr> </tbody> </table> # Feedback. Gain = 1, configuration only.		ACE00	ACE01		000b	ACE01	ACE00		001b	VBG	VBG		010b	Switch 5 & 7	Switch 5 & 7		011b	Mux Bus	Mux Bus	For the CY8C21x34, CY7C603xx, and CYWUSB6953 only: Chip-wide analog mux bus.	100b	FB#	FB#		101b	ASE10	ASE11		110b	ASE11	ASE10		111b	Port Inputs	Port Inputs	
	ACE00	ACE01																																				
000b	ACE01	ACE00																																				
001b	VBG	VBG																																				
010b	Switch 5 & 7	Switch 5 & 7																																				
011b	Mux Bus	Mux Bus	For the CY8C21x34, CY7C603xx, and CYWUSB6953 only: Chip-wide analog mux bus.																																			
100b	FB#	FB#																																				
101b	ASE10	ASE11																																				
110b	ASE11	ASE10																																				
111b	Port Inputs	Port Inputs																																				
2:0	PMux[2:0]	Encoding for positive input select. Note that available mux inputs vary by individual PSoC block. <table border="0"> <thead> <tr> <th></th> <th>ACE00</th> <th>ACE01</th> <th></th> </tr> </thead> <tbody> <tr> <td>000b</td> <td>Reserved</td> <td>V_{TEMP}</td> <td></td> </tr> <tr> <td>001b</td> <td>Port Inputs</td> <td>Port Inputs</td> <td></td> </tr> <tr> <td>010b</td> <td>ACE01</td> <td>ACE00</td> <td></td> </tr> <tr> <td>011b</td> <td>VBG</td> <td>VBG</td> <td></td> </tr> <tr> <td>100b</td> <td>ASE10</td> <td>ASE11</td> <td></td> </tr> <tr> <td>101b</td> <td>ASE11</td> <td>ASE10</td> <td></td> </tr> <tr> <td>110b</td> <td>Switch 1 & 4</td> <td>Switch 1 & 4</td> <td></td> </tr> <tr> <td>111b</td> <td>Mux Bus</td> <td>Mux Bus</td> <td>For the CY8C21x34, CY7C603xx, and CYWUSB6953 only: Chip-wide analog mux bus.</td> </tr> </tbody> </table>		ACE00	ACE01		000b	Reserved	V _{TEMP}		001b	Port Inputs	Port Inputs		010b	ACE01	ACE00		011b	VBG	VBG		100b	ASE10	ASE11		101b	ASE11	ASE10		110b	Switch 1 & 4	Switch 1 & 4		111b	Mux Bus	Mux Bus	For the CY8C21x34, CY7C603xx, and CYWUSB6953 only: Chip-wide analog mux bus.
	ACE00	ACE01																																				
000b	Reserved	V _{TEMP}																																				
001b	Port Inputs	Port Inputs																																				
010b	ACE01	ACE00																																				
011b	VBG	VBG																																				
100b	ASE10	ASE11																																				
101b	ASE11	ASE10																																				
110b	Switch 1 & 4	Switch 1 & 4																																				
111b	Mux Bus	Mux Bus	For the CY8C21x34, CY7C603xx, and CYWUSB6953 only: Chip-wide analog mux bus.																																			

13.2.40 ACBxxCR2

Analog Continuous Time Type B Block Control Register 2

Individual Register Names and Addresses:

ACB00CR2 : x,73h ACB01CR2 : x,77h ACB02CR2 : x,7Bh ACB03CR2 : x,7Fh

	7	6	5	4	3	2	1	0
Access : POR	RW : 0	RW : 0	RW : 0	RW : 0	RW : 0		RW : 0	
Bit Name	CPhase	CLatch	CompCap	TMUXEN	TestMux[1:0]		PWR[1:0]	

This register is one of four registers used to configure a type B continuous time PSoC block.

The register naming convention for arrays of PSoC blocks and their registers is <Prefix>mn<Suffix>, where m=row index, n=column index; therefore, ACB01CR2 is a register for an analog PSoC block in row 0 column 1. Depending on the analog column characteristics of your PSoC device (see the table titled “PSoC Device Characteristics” on page 371), some addresses may not be available. For additional information, refer to the “Register Definitions” on page 417 in the Continuous Time Block chapter.

This register is used for all PSoC devices except the two column limited CY8C21x34, CY8C21x23, CY7C603xx, and CYWUSB6953 PSoC devices, which use Type E blocks. For two column limited PSoC devices, refer to the ACExxCR2 register following this register.

Bits	Name	Description																													
7	CPhase	0 Comparator Control latch is transparent on PHI1. 1 Comparator Control latch is transparent on PHI2.																													
6	CLatch	0 Comparator Control latch is always transparent. 1 Comparator Control latch is active.																													
5	CompCap	0 Comparator Mode 1 Opamp Mode																													
4	TMUXEN	Test Mux 0 Disabled 1 Enabled																													
3:2	TestMux[1:0]	Select block bypass mode. Note that available mux inputs vary by individual PSoC block and TMUXEN must be set. In the table below, column ACB01 is used by the one column PSoC blocks, columns ACB00 and ACB01 are used by the 2 column PSoC blocks, and all columns are used by the 4 column PSoC blocks.																													
		<table border="0"> <thead> <tr> <th></th> <th>ACB00</th> <th>ACB01</th> <th>ACB02</th> <th>ACB03</th> </tr> </thead> <tbody> <tr> <td>00b</td> <td>Positive Input to</td> <td>ABUS0</td> <td>ABUS1</td> <td>ABUS2</td> <td>ABUS3</td> </tr> <tr> <td>01b</td> <td>AGND to</td> <td>ABUS0</td> <td>ABUS1</td> <td>ABUS2</td> <td>ABUS3</td> </tr> <tr> <td>10b</td> <td>RefLo to</td> <td>ABUS0</td> <td>ABUS1</td> <td>ABUS2</td> <td>ABUS3</td> </tr> <tr> <td>11b</td> <td>RefHi to</td> <td>ABUS0</td> <td>ABUS1</td> <td>ABUS2</td> <td>ABUS3</td> </tr> </tbody> </table>		ACB00	ACB01	ACB02	ACB03	00b	Positive Input to	ABUS0	ABUS1	ABUS2	ABUS3	01b	AGND to	ABUS0	ABUS1	ABUS2	ABUS3	10b	RefLo to	ABUS0	ABUS1	ABUS2	ABUS3	11b	RefHi to	ABUS0	ABUS1	ABUS2	ABUS3
	ACB00	ACB01	ACB02	ACB03																											
00b	Positive Input to	ABUS0	ABUS1	ABUS2	ABUS3																										
01b	AGND to	ABUS0	ABUS1	ABUS2	ABUS3																										
10b	RefLo to	ABUS0	ABUS1	ABUS2	ABUS3																										
11b	RefHi to	ABUS0	ABUS1	ABUS2	ABUS3																										
1:0	PWR[1:0]	Encoding for selecting one of four power levels. High Bias mode doubles the power at each of these settings. See bit 6 in the ARF_CR register on page 179. 00b Off 01b Low 10b Medium 11b High																													

13.2.41 ACExxCR2

Analog Continuous Time Type E Block Control Register 2 (Dual Purpose Address, see “Mapping Exceptions” on page 141)

Individual Register Names and Addresses:

ACE00CR2 : x,73h ACE01CR2 : x,77h

2L COLUMN	7	6	5	4	3	2	1	0
Access : POR							RW : 0	RW : 0
Bit Name							FullRange	PWR

This register is one of two registers used to configure the type E continuous time PSoC block.

This register is only used by the CY8C21x34, CY8C21x23, CY7C603xx, and CYWUSB6953 PSoC devices. The register naming convention for arrays of PSoC blocks and their registers is <Prefix>mn<Suffix>, where m=row index, n=column index; therefore, ACB01CR2 is a register for an analog PSoC block in row 0 column 1. Depending on the analog column configuration of your PSoC device (see the table titled “PSoC Device Characteristics” on page 371), some addresses may not be available.

In the table above, note that reserved bits are grayed table cells and are not described in the bit description section below. Reserved bits should always be written with a value of ‘0’. For additional information, refer to the “Register Definitions” on page 443 in the [Two Column Limited Analog System](#) chapter on page 431.

Bits	Name	Description	
1	FullRange	0	Input range includes Vss but not Vdd.
		1	Rail-to-rail input range, with approximately 10 μ A additional cell current.
0	PWR	0	Powers off both the CT and SC blocks in the column.
		1	Enables the column’s analog blocks.

13.2.42 ASCxxCR0

Analog Switch Cap Type C Block Control Register 0

Individual Register Names and Addresses:

ASC10CR0 : x,80h ASC12CR0 : x,88h ASC21CR0 : x,94h ASC23CR0 : x,9Ch

	7	6	5	4	3	2	1	0
Access : POR	RW : 0	RW : 0	RW : 0			RW : 00		
Bit Name	FCap	ClockPhase	ASign			ACap[4:0]		

This register is one of four registers used to configure a type C switch capacitor PSoC block.

The register naming convention for arrays of PSoC blocks and their registers is <Prefix>mn<Suffix>, where m=row index, n=column index; therefore, ASC12CR0 is a register for an analog PSoC block in row 1 column 2. Depending on the analog column characteristics of your PSoC device (see the table titled “PSoC Device Characteristics” on page 371), some addresses may not be available. For additional information, refer to the “Register Definitions” on page 424 in the Switched Capacitor Block chapter.

This register is used for all PSoC devices except the two column limited CY8C21x34, CY8C21x23, CY7C603xx, and CYWUSB6953 PSoC devices, which use Type E blocks. For two column limited PSoC devices, refer to the ASExxCR0 register following this register.

Bits	Name	Description
7	FCap	F Capacitor value selection bit. 0 16 capacitor units 1 32 capacitor units
6	ClockPhase	The ClockPhase controls the clock phase of the comparator within the switched cap blocks, as well as the clock phase of the switches. 0 Switch phasing is Internal PHI1 = External PHI1. Comparator Capture Point Event is triggered by Falling PHI2 and Comparator Output Point Event is triggered by Rising PHI1. 1 Switch phasing is Internal PHI1 = External PHI2. Comparator Capture Point Event is triggered by Falling PHI1 and Comparator Output Point Event is triggered by Rising PHI2.
5	ASign	0 Input sampled on Internal PHI1. Reference Input sampled on Internal PHI2. Positive gain. 1 Input sampled on Internal PHI2. Reference Input sampled on Internal PHI1. Negative gain.
4:0	ACap[4:0]	Binary encoding for 32 possible capacitor sizes for capacitor ACap.

13.2.43 ASExxCR0

Analog Switch Cap Type E Block Control Register 0 (Dual Purpose Address, see “Mapping Exceptions” on page 141)

Individual Register Names and Addresses:

ASE10CR0 : x,80h ASE11CR0 : x,84h

2L COLUMN	7	6	5	4	3	2	1	0
Access : POR	RW : 0							
Bit Name	FVal							

This register is used to configure a type E switched capacitor PSoC block.

This register is only used by the CY8C21x34, CY8C21x23, CY7C603xx, and CYWUSB6953 PSoC devices. In the table above, note that reserved bits are grayed table cells and are not described in the bit description section below. Reserved bits should always be written with a value of '0'. For additional information, refer to the “Register Definitions” on page 443 in the Two Column Limited Analog System chapter on page 431.

Bits	Name	Description
7	FVal	F Capacitor value selection bit. 0 Slower integration in the SC block (higher accuracy) 1 Faster integration (lower accuracy)

13.2.44 ASCxxCR1

Analog Switch Cap Type C Block Control Register 1

Individual Register Names and Addresses:

ASC10CR1 : x,81h ASC12CR1 : x,89h ASC21CR1 : x,95h ASC23CR1 : x,9Dh

	7	6	5	4	3	2	1	0
Access : POR	RW : 0			RW : 00				
Bit Name	ACMux[2:0]			BCap[4:0]				

This register is one of four registers used to configure a type C switch capacitor PSoC block.

The register naming convention for arrays of PSoC blocks and their registers is <Prefix>mn<Suffix>, where m=row index, n=column index; therefore, ASC12CR1 is a register for an analog PSoC block in row 1 column 2. Depending on the analog column characteristics of your PSoC device (see the table titled “PSoC Device Characteristics” on page 371), some addresses may not be available. For additional information, refer to the “Register Definitions” on page 424 in the Switched Capacitor Block chapter.

Bits	Name	Description																																																																																																																																																																										
7:5	ACMux[2:0]	Encoding to select A and C inputs. (Note that available mux inputs vary by individual block.) For 4 Column Analog PSoC Blocks: <table border="0" style="margin-left: 20px;"> <thead> <tr> <th></th> <th colspan="2">ASC10</th> <th colspan="2">ASC21</th> <th colspan="2">ASC12</th> <th colspan="2">ASC23</th> </tr> <tr> <th></th> <th>A Inputs</th> <th>C Inputs</th> <th>A Inputs</th> <th>C Inputs</th> <th>A Inputs</th> <th>C Inputs</th> <th>A Inputs</th> <th>C Inputs</th> </tr> </thead> <tbody> <tr><td>000b</td><td>ACB00</td><td>ACB00</td><td>ASD11</td><td>ASD11</td><td>ACB02</td><td>ACB02</td><td>ASD13</td><td>ASD13</td></tr> <tr><td>001b</td><td>ASD11</td><td>ACB00</td><td>ASD20</td><td>ASD11</td><td>ASD13</td><td>ACB02</td><td>ASD22</td><td>ASD13</td></tr> <tr><td>010b</td><td>RefHi</td><td>ACB00</td><td>RefHi</td><td>ASD11</td><td>RefHi</td><td>ACB02</td><td>RefHi</td><td>ASD13</td></tr> <tr><td>011b</td><td>ASD20</td><td>ACB00</td><td>Vtemp</td><td>ASD11</td><td>ASD22</td><td>ACB02</td><td>ABUS3</td><td>ASD13</td></tr> <tr><td>100b</td><td>ACB01</td><td>ASD20</td><td>ASC10</td><td>ASD11</td><td>ACB03</td><td>ASD22</td><td>ASC12</td><td>ASD13</td></tr> <tr><td>101b</td><td>ACB00</td><td>ASD20</td><td>ASD20</td><td>ASD11</td><td>ACB02</td><td>ASD22</td><td>ASD22</td><td>ASD13</td></tr> <tr><td>110b</td><td>ASD11</td><td>ASD20</td><td>ABUS1</td><td>ASD11</td><td>ASD13</td><td>ASD22</td><td>ABUS3</td><td>ASD13</td></tr> <tr><td>111b</td><td>P2[1]</td><td>ASD20</td><td>ASD22</td><td>ASD11</td><td>ASD11</td><td>ASD22</td><td>P2[2]</td><td>ASD13</td></tr> </tbody> </table> For 2 Column Analog PSoC Blocks: <table border="0" style="margin-left: 20px;"> <thead> <tr> <th></th> <th colspan="2">ASC10</th> <th colspan="2">ASC21</th> </tr> <tr> <th></th> <th>A Inputs</th> <th>C Inputs</th> <th>A Inputs</th> <th>C Inputs</th> </tr> </thead> <tbody> <tr><td>000b</td><td>ACB00</td><td>ACB00</td><td>ASD11</td><td>ASD11</td></tr> <tr><td>001b</td><td>ASD11</td><td>ACB00</td><td>ASD20</td><td>ASD11</td></tr> <tr><td>010b</td><td>RefHi</td><td>ACB00</td><td>RefHi</td><td>ASD11</td></tr> <tr><td>011b</td><td>ASD20</td><td>ACB00</td><td>Vtemp</td><td>ASD11</td></tr> <tr><td>100b</td><td>ACB01</td><td>ASD20</td><td>ASC10</td><td>ASD11</td></tr> <tr><td>101b</td><td>ACB00</td><td>ASD20</td><td>ASD20</td><td>ASD11</td></tr> <tr><td>110b</td><td>ASD11</td><td>ASD20</td><td>ABUS1</td><td>ASD11</td></tr> <tr><td>111b</td><td>P2[1]</td><td>ASD20</td><td>P2[2]</td><td>ASD11</td></tr> </tbody> </table> For 1 Column Analog PSoC Blocks: <table border="0" style="margin-left: 20px;"> <thead> <tr> <th></th> <th colspan="2">ASC21</th> </tr> <tr> <th></th> <th>A Inputs</th> <th>C Inputs</th> </tr> </thead> <tbody> <tr><td>000b</td><td>ASD11</td><td>ASD11</td></tr> <tr><td>001b</td><td>Reserved</td><td>Reserved</td></tr> <tr><td>010b</td><td>Vdd</td><td>ASD11</td></tr> <tr><td>011b</td><td>Vtemp</td><td>ASD11</td></tr> <tr><td>100b</td><td>Reserved</td><td>Reserved</td></tr> <tr><td>101b</td><td>Reserved</td><td>Reserved</td></tr> <tr><td>110b</td><td>ABUS1</td><td>ASD11</td></tr> <tr><td>111b</td><td>Reserved</td><td>Reserved</td></tr> </tbody> </table>		ASC10		ASC21		ASC12		ASC23			A Inputs	C Inputs	A Inputs	C Inputs	A Inputs	C Inputs	A Inputs	C Inputs	000b	ACB00	ACB00	ASD11	ASD11	ACB02	ACB02	ASD13	ASD13	001b	ASD11	ACB00	ASD20	ASD11	ASD13	ACB02	ASD22	ASD13	010b	RefHi	ACB00	RefHi	ASD11	RefHi	ACB02	RefHi	ASD13	011b	ASD20	ACB00	Vtemp	ASD11	ASD22	ACB02	ABUS3	ASD13	100b	ACB01	ASD20	ASC10	ASD11	ACB03	ASD22	ASC12	ASD13	101b	ACB00	ASD20	ASD20	ASD11	ACB02	ASD22	ASD22	ASD13	110b	ASD11	ASD20	ABUS1	ASD11	ASD13	ASD22	ABUS3	ASD13	111b	P2[1]	ASD20	ASD22	ASD11	ASD11	ASD22	P2[2]	ASD13		ASC10		ASC21			A Inputs	C Inputs	A Inputs	C Inputs	000b	ACB00	ACB00	ASD11	ASD11	001b	ASD11	ACB00	ASD20	ASD11	010b	RefHi	ACB00	RefHi	ASD11	011b	ASD20	ACB00	Vtemp	ASD11	100b	ACB01	ASD20	ASC10	ASD11	101b	ACB00	ASD20	ASD20	ASD11	110b	ASD11	ASD20	ABUS1	ASD11	111b	P2[1]	ASD20	P2[2]	ASD11		ASC21			A Inputs	C Inputs	000b	ASD11	ASD11	001b	Reserved	Reserved	010b	Vdd	ASD11	011b	Vtemp	ASD11	100b	Reserved	Reserved	101b	Reserved	Reserved	110b	ABUS1	ASD11	111b	Reserved	Reserved
	ASC10		ASC21		ASC12		ASC23																																																																																																																																																																					
	A Inputs	C Inputs	A Inputs	C Inputs	A Inputs	C Inputs	A Inputs	C Inputs																																																																																																																																																																				
000b	ACB00	ACB00	ASD11	ASD11	ACB02	ACB02	ASD13	ASD13																																																																																																																																																																				
001b	ASD11	ACB00	ASD20	ASD11	ASD13	ACB02	ASD22	ASD13																																																																																																																																																																				
010b	RefHi	ACB00	RefHi	ASD11	RefHi	ACB02	RefHi	ASD13																																																																																																																																																																				
011b	ASD20	ACB00	Vtemp	ASD11	ASD22	ACB02	ABUS3	ASD13																																																																																																																																																																				
100b	ACB01	ASD20	ASC10	ASD11	ACB03	ASD22	ASC12	ASD13																																																																																																																																																																				
101b	ACB00	ASD20	ASD20	ASD11	ACB02	ASD22	ASD22	ASD13																																																																																																																																																																				
110b	ASD11	ASD20	ABUS1	ASD11	ASD13	ASD22	ABUS3	ASD13																																																																																																																																																																				
111b	P2[1]	ASD20	ASD22	ASD11	ASD11	ASD22	P2[2]	ASD13																																																																																																																																																																				
	ASC10		ASC21																																																																																																																																																																									
	A Inputs	C Inputs	A Inputs	C Inputs																																																																																																																																																																								
000b	ACB00	ACB00	ASD11	ASD11																																																																																																																																																																								
001b	ASD11	ACB00	ASD20	ASD11																																																																																																																																																																								
010b	RefHi	ACB00	RefHi	ASD11																																																																																																																																																																								
011b	ASD20	ACB00	Vtemp	ASD11																																																																																																																																																																								
100b	ACB01	ASD20	ASC10	ASD11																																																																																																																																																																								
101b	ACB00	ASD20	ASD20	ASD11																																																																																																																																																																								
110b	ASD11	ASD20	ABUS1	ASD11																																																																																																																																																																								
111b	P2[1]	ASD20	P2[2]	ASD11																																																																																																																																																																								
	ASC21																																																																																																																																																																											
	A Inputs	C Inputs																																																																																																																																																																										
000b	ASD11	ASD11																																																																																																																																																																										
001b	Reserved	Reserved																																																																																																																																																																										
010b	Vdd	ASD11																																																																																																																																																																										
011b	Vtemp	ASD11																																																																																																																																																																										
100b	Reserved	Reserved																																																																																																																																																																										
101b	Reserved	Reserved																																																																																																																																																																										
110b	ABUS1	ASD11																																																																																																																																																																										
111b	Reserved	Reserved																																																																																																																																																																										
4:0	BCap[4:0]	Binary encoding for 32 possible capacitor sizes of the capacitor BCap.																																																																																																																																																																										

13.2.45 ASCxxCR2

Analog Switch Cap Type C Block Control Register 2

Individual Register Names and Addresses:

ASC10CR2 : x,82h

ASC12CR2 : x,8Ah

ASC21CR2 : x,96h

ASC23CR2 : x,9Eh

	7	6	5	4	3	2	1	0
Access : POR	RW : 0	RW : 0	RW : 0			RW : 00		
Bit Name	AnalogBus	CompBus	AutoZero			CCap[4:0]		

This register is one of four registers used to configure a type C switch capacitor PSoC block.

The register naming convention for arrays of PSoC blocks and their registers is <Prefix>mn<Suffix>, where m=row index, n=column index; therefore, ASC12CR2 is a register for an analog PSoC block in row 1 column 2. Depending on the analog column characteristics of your PSoC device (see the table titled “PSoC Device Characteristics” on page 371), some addresses may not be available. For additional information, refer to the “Register Definitions” on page 424 in the Switched Capacitor Block chapter.

Bits	Name	Description
7	AnalogBus	Enable output to the analog bus. Note that ClockPhase in the ASCxxCR0 register on page 195 , bit 6, also affects this bit: Sample + Hold mode is allowed only if ClockPhase = 0. 0 Disable output to analog column bus. 1 Enable output to analog column bus.
6	CompBus	Enable output to the comparator bus. 0 Disable output to comparator bus. 1 Enable output to comparator bus.
5	AutoZero	Bit for controlling gated switches. 0 Shorting switch is not active. Input cap branches shorted to opamp input. 1 Shorting switch is enabled during Internal PHI1. Input cap branches shorted to analog ground during Internal PHI1 and to opamp input during Internal PHI2.
4:0	CCap[4:0]	Binary encoding for 32 possible capacitor sizes of the capacitor CCap.

13.2.46 ASCxxCR3

Analog Switch Cap Type C Block Control Register 3

Individual Register Names and Addresses:

ASC10CR3 : x,83h

ASC12CR3 : x,8Bh

ASC21CR3 : x,97h

ASC23CR3 : x,9Fh

	7	6	5	4	3	2	1	0
Access : POR	RW : 0		RW : 0	RW : 0	RW : 0		RW : 0	
Bit Name	ARefMux[1:0]		FSW1	FSW0	BMuxSC[1:0]		PWR[1:0]	

This register is one of four registers used to configure a type C switch capacitor PSoC block.

The register naming convention for arrays of PSoC blocks and their registers is <Prefix>mn<Suffix>, where m=row index, n=column index; therefore, ASC12CR3 is a register for an analog PSoC block in row 1 column 2. Depending on the analog column characteristics of your PSoC device (see the table titled “PSoC Device Characteristics” on page 371), some addresses may not be available. For additional information, refer to the “Register Definitions” on page 424 in the Switched Capacitor Block chapter.

Bits	Name	Description																																																		
7:6	ARefMux[1:0]	Encoding for selecting reference input. 00b Analog ground is selected. 01b RefHi input selected. 10b RefLo input selected. 11b Reference selection is driven by the comparator. (When output comparator node is set high, the input is set to RefHi. When set low, the input is set to RefLo.)																																																		
5	FSW1	Bit for controlling the FSW1 switch. 0 Switch is disabled. 1 If the FSW1 bit is set to '1', the state of the switch is determined by the AutoZero bit. If the AutoZero bit is '0', the switch is enabled at all times. If the AutoZero bit is '1', the switch is enabled only when the Internal PHI2 is high.																																																		
4	FSW0	Bit for controlling the FSW0 switch. 0 Switch is disabled. 1 Switch is enabled when PHI1 is high.																																																		
3:2	BMuxSC[1:0]	Encoding for selecting B inputs. Note that the available mux inputs vary by individual PSoC block. For 4 Column Analog PSoC Blocks: <table border="0"> <thead> <tr> <th></th> <th>ASC10</th> <th>ASC21</th> <th>ASC12</th> <th>ASC23</th> </tr> </thead> <tbody> <tr> <td>00b</td> <td>ACB00</td> <td>ASD11</td> <td>ACB02</td> <td>ASD13</td> </tr> <tr> <td>01b</td> <td>ASD11</td> <td>ASD20</td> <td>ASD13</td> <td>ASD22</td> </tr> <tr> <td>10b</td> <td>P2[3]</td> <td>ASD22</td> <td>ASD11</td> <td>P2[0]</td> </tr> <tr> <td>11b</td> <td>ASD20</td> <td>TrefGND</td> <td>ASD22</td> <td>ABUS3</td> </tr> </tbody> </table> For 2 Column Analog PSoC Blocks: <table border="0"> <thead> <tr> <th></th> <th>ASC10</th> <th>ASC21</th> </tr> </thead> <tbody> <tr> <td>00b</td> <td>ACB00</td> <td>ASD11</td> </tr> <tr> <td>01b</td> <td>ASD11</td> <td>ASD20</td> </tr> <tr> <td>10b</td> <td>P2[3]</td> <td>P2[0]</td> </tr> <tr> <td>11b</td> <td>ASD20</td> <td>TrefGND</td> </tr> </tbody> </table> For 1 Column Analog PSoC Blocks: <table border="0"> <thead> <tr> <th></th> <th>ASC21</th> </tr> </thead> <tbody> <tr> <td>00b</td> <td>ASD11</td> </tr> <tr> <td>01b</td> <td>Reserved</td> </tr> <tr> <td>10b</td> <td>Reserved</td> </tr> <tr> <td>11b</td> <td>TrefGND</td> </tr> </tbody> </table>		ASC10	ASC21	ASC12	ASC23	00b	ACB00	ASD11	ACB02	ASD13	01b	ASD11	ASD20	ASD13	ASD22	10b	P2[3]	ASD22	ASD11	P2[0]	11b	ASD20	TrefGND	ASD22	ABUS3		ASC10	ASC21	00b	ACB00	ASD11	01b	ASD11	ASD20	10b	P2[3]	P2[0]	11b	ASD20	TrefGND		ASC21	00b	ASD11	01b	Reserved	10b	Reserved	11b	TrefGND
	ASC10	ASC21	ASC12	ASC23																																																
00b	ACB00	ASD11	ACB02	ASD13																																																
01b	ASD11	ASD20	ASD13	ASD22																																																
10b	P2[3]	ASD22	ASD11	P2[0]																																																
11b	ASD20	TrefGND	ASD22	ABUS3																																																
	ASC10	ASC21																																																		
00b	ACB00	ASD11																																																		
01b	ASD11	ASD20																																																		
10b	P2[3]	P2[0]																																																		
11b	ASD20	TrefGND																																																		
	ASC21																																																			
00b	ASD11																																																			
01b	Reserved																																																			
10b	Reserved																																																			
11b	TrefGND																																																			
1:0	PWR[1:0]	Encoding for selecting one of four power levels. 00b Off 01b Low 10b Medium 11b High																																																		

13.2.47 ASDxxCR0

Analog Switch Cap Type D Block Control Register 0

Individual Register Names and Addresses:

ASD11CR0 : x,84h

ASD13CR0 : x,8Ch

ASD20CR0 : x,90h

ASD22CR0 : x,98h

	7	6	5	4	3	2	1	0
Access : POR	RW : 0	RW : 0	RW : 0			RW : 00		
Bit Name	FCap	ClockPhase	ASign			ACap[4:0]		

This register is one of four registers used to configure a type D switch capacitor PSoC block.

The register naming convention for arrays of PSoC blocks and their registers is <Prefix>mn<Suffix>, where m=row index, n=column index; therefore, ASD13CR0 is a register for an analog PSoC block in row 1 column 3. Depending on the analog column characteristics of your PSoC device (see the table titled “PSoC Device Characteristics” on page 371), some addresses may not be available. For additional information, refer to the “Register Definitions” on page 424 in the Switched Capacitor Block chapter.

This register is used for all PSoC devices except the two column limited CY8C21x34, CY8C21x23, CY7C603xx, and CYWUSB6953 PSoC devices, which use Type E blocks. For two column limited PSoC devices, refer to the [ASExxCR0 register](#) on page 196.

Bits	Name	Description
7	FCap	F Capacitor value selection bit. 0 16 capacitor units 1 32 capacitor units
6	ClockPhase	The ClockPhase controls the clock phase of the comparator within the switched cap blocks, as well as the clock phase of the switches. 0 Switch phasing is Internal PHI1 = External PHI1. Comparator Capture Point Event is triggered by Falling PHI2 and Comparator Output Point Event is triggered by Rising PHI1. 1 Switch phasing is Internal PHI1 = External PHI2. Comparator Capture Point Event is triggered by Falling PHI1 and Comparator Output Point Event is triggered by Rising PHI2.
5	ASign	0 Input sampled on Internal PHI1. Reference Input sampled on Internal PHI2. Positive gain. 1 Input sampled on Internal PHI2. Reference Input sampled on Internal PHI1. Negative gain.
4:0	ACap[4:0]	Binary encoding for 32 possible capacitor sizes for capacitor ACap.

13.2.48 ASDxxCR1

Analog Switch Cap Type D Block Control Register 1

Individual Register Names and Addresses:

ASD11CR1 : x,85h ASD13CR1 : x,8Dh ASD20CR1 : x,91h ASD22CR1 : x,99h

	7	6	5	4	3	2	1	0
Access : POR	RW : 0			RW : 00				
Bit Name	AMux[2:0]			BCap[4:0]				

This register is one of four registers used to configure a type D switch capacitor PSoC block.

The register naming convention for arrays of PSoC blocks and their registers is <Prefix>mn<Suffix>, where m=row index, n=column index; therefore, ASD13CR1 is a register for an analog PSoC block in row 1 column 3. Depending on the analog column characteristics of your PSoC device (see the table titled “PSoC Device Characteristics” on page 371), some addresses may not be available. For additional information, refer to the “Register Definitions” on page 424 in the Switched Capacitor Block chapter.

Bits	Name	Description																																																																																										
7:5	AMux[2:0]	<p>Encoding for selecting A and C inputs for C Type blocks and A inputs for D Type blocks. (Note that available mux inputs vary by individual PSoC block.) In the table below, only columns ASD20 and ASD11 are used by the 2 column analog PSoC blocks and all columns are used by the 4 column analog PSoC blocks.</p> <table border="1"> <thead> <tr> <th></th> <th>ASD20</th> <th>ASD11</th> <th>ASD22</th> <th>ASD13</th> </tr> </thead> <tbody> <tr><td>000b</td><td>ASC10</td><td>ACB01</td><td>ASC12</td><td>ACB03</td></tr> <tr><td>001b</td><td>P2[1]</td><td>ASC12</td><td>ASC21</td><td>P2[2]</td></tr> <tr><td>010b</td><td>ASC21</td><td>ASC10</td><td>ASC23</td><td>ASC12</td></tr> <tr><td>011b</td><td>ABUS0</td><td>ASC21</td><td>ABUS2</td><td>ASC23</td></tr> <tr><td>100b</td><td>RefHi</td><td>RefHi</td><td>RefHi</td><td>RefHi</td></tr> <tr><td>101b</td><td>ASD11</td><td>ACB00</td><td>ASD13</td><td>ACB02</td></tr> <tr><td>110b</td><td>Reserved</td><td>Reserved</td><td>Reserved</td><td>Reserved</td></tr> <tr><td>111b</td><td>Reserved</td><td>Reserved</td><td>Reserved</td><td>Reserved</td></tr> </tbody> </table> <p>The following table is used by the 2 column analog PSoC blocks.</p> <table border="1"> <thead> <tr> <th></th> <th>ASD20</th> <th>ASD11</th> </tr> </thead> <tbody> <tr><td>000b</td><td>ASC10</td><td>ACB01</td></tr> <tr><td>001b</td><td>P2[1]</td><td>P2[2]</td></tr> <tr><td>010b</td><td>ASC21</td><td>ASC10</td></tr> <tr><td>011b</td><td>ABUS0</td><td>ASC21</td></tr> <tr><td>100b</td><td>RefHi</td><td>RefHi</td></tr> <tr><td>101b</td><td>ASD11</td><td>ACB00</td></tr> <tr><td>110b</td><td>Reserved</td><td>Reserved</td></tr> <tr><td>111b</td><td>Reserved</td><td>Reserved</td></tr> </tbody> </table> <p>The following table is used by the 1 column analog PSoC blocks.</p> <table border="1"> <thead> <tr> <th></th> <th>ASD11</th> </tr> </thead> <tbody> <tr><td>000b</td><td>ACB01</td></tr> <tr><td>001b</td><td>Reserved</td></tr> <tr><td>010b</td><td>Reserved</td></tr> <tr><td>011b</td><td>ASC21</td></tr> <tr><td>100b</td><td>Vdd</td></tr> <tr><td>101b</td><td>Reserved</td></tr> <tr><td>110b</td><td>Reserved</td></tr> <tr><td>111b</td><td>Reserved</td></tr> </tbody> </table>		ASD20	ASD11	ASD22	ASD13	000b	ASC10	ACB01	ASC12	ACB03	001b	P2[1]	ASC12	ASC21	P2[2]	010b	ASC21	ASC10	ASC23	ASC12	011b	ABUS0	ASC21	ABUS2	ASC23	100b	RefHi	RefHi	RefHi	RefHi	101b	ASD11	ACB00	ASD13	ACB02	110b	Reserved	Reserved	Reserved	Reserved	111b	Reserved	Reserved	Reserved	Reserved		ASD20	ASD11	000b	ASC10	ACB01	001b	P2[1]	P2[2]	010b	ASC21	ASC10	011b	ABUS0	ASC21	100b	RefHi	RefHi	101b	ASD11	ACB00	110b	Reserved	Reserved	111b	Reserved	Reserved		ASD11	000b	ACB01	001b	Reserved	010b	Reserved	011b	ASC21	100b	Vdd	101b	Reserved	110b	Reserved	111b	Reserved
	ASD20	ASD11	ASD22	ASD13																																																																																								
000b	ASC10	ACB01	ASC12	ACB03																																																																																								
001b	P2[1]	ASC12	ASC21	P2[2]																																																																																								
010b	ASC21	ASC10	ASC23	ASC12																																																																																								
011b	ABUS0	ASC21	ABUS2	ASC23																																																																																								
100b	RefHi	RefHi	RefHi	RefHi																																																																																								
101b	ASD11	ACB00	ASD13	ACB02																																																																																								
110b	Reserved	Reserved	Reserved	Reserved																																																																																								
111b	Reserved	Reserved	Reserved	Reserved																																																																																								
	ASD20	ASD11																																																																																										
000b	ASC10	ACB01																																																																																										
001b	P2[1]	P2[2]																																																																																										
010b	ASC21	ASC10																																																																																										
011b	ABUS0	ASC21																																																																																										
100b	RefHi	RefHi																																																																																										
101b	ASD11	ACB00																																																																																										
110b	Reserved	Reserved																																																																																										
111b	Reserved	Reserved																																																																																										
	ASD11																																																																																											
000b	ACB01																																																																																											
001b	Reserved																																																																																											
010b	Reserved																																																																																											
011b	ASC21																																																																																											
100b	Vdd																																																																																											
101b	Reserved																																																																																											
110b	Reserved																																																																																											
111b	Reserved																																																																																											
4:0	BCap[4:0]	Binary encoding for 32 possible capacitor sizes for capacitor BCap.																																																																																										

13.2.49 ASDxxCR2

Analog Switch Cap Type D Block Control Register 2

Individual Register Names and Addresses:

ASD11CR2 : x,86h

ASD13CR2 : x,8Eh

ASD20CR2 : x,92h

ASD22CR2 : x,9Ah

	7	6	5	4	3	2	1	0
Access : POR	RW : 0	RW : 0	RW : 0			RW : 00		
Bit Name	AnalogBus	CompBus	AutoZero			CCap[4:0]		

This register is one of four registers used to configure a type D switch capacitor PSoC block.

The register naming convention for arrays of PSoC blocks and their registers is <Prefix>mn<Suffix>, where m=row index, n=column index; therefore, ASD13CR2 is a register for an analog PSoC block in row 1 column 3. Depending on the analog column characteristics of your PSoC device (see the table titled “PSoC Device Characteristics” on page 371), some addresses may not be available. For additional information, refer to the “Register Definitions” on page 424 in the Switched Capacitor Block chapter.

Bits	Name	Description
7	AnalogBus	Enable output to the analog bus. Note that ClockPhase in ASDxxCR0 register, bit 6, also effect this bit: Sample + Hold mode is allowed only if ClockPhase = 0. 0 Disable output to analog column bus. 1 Enable output to analog column bus.
6	CompBus	Enable output to the comparator bus. 0 Disable output to comparator bus. 1 Enable output to comparator bus.
5	AutoZero	Bit for controlling the AutoZero switch. 0 Shorting switch is not active. Input cap branches shorted to opamp input. 1 Shorting switch is enabled during Internal PHI1. Input cap branches shorted to analog ground during Internal PHI1 and to opamp input during Internal PHI2.
4:0	CCap[4:0]	Binary encoding for 32 possible capacitor sizes for capacitor CCap.

13.2.50 ASDxxCR3

Analog Switch Cap Type D Block Control Register 3

Individual Register Names and Addresses:

ASD11CR3 : x,87h

ASD13CR3 : x,8Fh

ASD20CR3 : x,93h

ASD22CR3 : x,9Bh

	7	6	5	4	3	2	1	0
Access : POR	RW : 0	RW : 0	RW : 0	RW : 0	RW : 0	RW : 0	RW : 0	RW : 0
Bit Name	ARefMux[1:0]	FSW1	FSW0	BSW	BMuxSD	PWR[1:0]		

This register is one of four registers used to configure a type D switch capacitor PSoC block.

The register naming convention for arrays of PSoC blocks and their registers is <Prefix>mn<Suffix>, where m=row index, n=column index; therefore, ASD13CR3 is a register for an analog PSoC block in row 1 column 3. Depending on the analog column characteristics of your PSoC device (see the table titled “PSoC Device Characteristics” on page 371), some addresses may not be available. For additional information, refer to the “Register Definitions” on page 424 in the Switched Capacitor Block chapter.

Bits	Name	Description																					
7:6	ARefMux[1:0]	Encoding for selecting reference input. 00b Analog ground is selected. 01b RefHi input selected. (This is usually the high reference.) 10b RefLo input selected. (This is usually the low reference.) 11b Reference selection is driven by the comparator. (When output comparator node is set high, the input is set to RefHi. When set low, the input is set to RefLo.)																					
5	FSW1	Bit for controlling gated switches. 0 Switch is disabled. 1 If the FSW1 bit is set to '1', the state of the switch is determined by the AutoZero bit. If the AutoZero bit is '0', the switch is enabled at all times. If the AutoZero bit is '1', the switch is enabled only when the Internal PHI2 is high.																					
4	FSW0	Bits for controlling gated switches. 0 Switch is disabled. 1 Switch is enabled when PHI1 is high.																					
3	BSW	Enable switching in branch. 0 B branch is a continuous time path. 1 B branch is switched with Internal PHI2 sampling.																					
2	BMuxSD	Encoding for selecting B inputs. (Note that the available mux inputs vary by individual PSoC block.) In the table below, only columns ASD20 and ASD11 are used by the 2 column analog PSoC blocks and all columns are used by the 4 column analog PSoC blocks. <table border="1" style="margin-left: 40px;"> <thead> <tr> <th></th> <th>ASD20</th> <th>ASD11</th> <th>ASD22</th> <th>ASD13</th> </tr> </thead> <tbody> <tr> <td>0</td> <td>ASD11</td> <td>ACB00</td> <td>ASD13</td> <td>ACB02</td> </tr> <tr> <td>1</td> <td>ASC10</td> <td>ACB01</td> <td>ASC12</td> <td>ACB03</td> </tr> </tbody> </table> The following table is used by the 1 column analog PSoC blocks. <table border="1" style="margin-left: 40px;"> <thead> <tr> <th></th> <th>ASD11</th> </tr> </thead> <tbody> <tr> <td>0</td> <td>Reserved</td> </tr> <tr> <td>1</td> <td>ACB01</td> </tr> </tbody> </table>		ASD20	ASD11	ASD22	ASD13	0	ASD11	ACB00	ASD13	ACB02	1	ASC10	ACB01	ASC12	ACB03		ASD11	0	Reserved	1	ACB01
	ASD20	ASD11	ASD22	ASD13																			
0	ASD11	ACB00	ASD13	ACB02																			
1	ASC10	ACB01	ASC12	ACB03																			
	ASD11																						
0	Reserved																						
1	ACB01																						
1:0	PWR[1:0]	Encoding for selecting one of four power levels. 00b Off 01b Low 10b Medium 11b High																					

13.2.51 MULx_X

Multiply Input X Register

Individual Register Names and Addresses:

MUL1_X : 0,A8h MUL0_X : 0,E8h

	7	6	5	4	3	2	1	0
Access : POR	W : XX							
Bit Name	Data[7:0]							

This register is one of two multiplicand registers for the signed 8-bit multiplier in the PSoC MAC.

This register is for 2 MAC block PSoC devices only. For additional information, refer to the “[Register Definitions](#)” on page 470 in the Multiply Accumulate chapter.

Bit	Name	Description
7:0	Data[7:0]	X multiplicand for MAC 8-bit multiplier.

13.2.52 MULx_Y

Multiply Input Y Register

Individual Register Names and Addresses:

MUL1_Y : 0,A9h MULO_Y : 0,E9h

	7	6	5	4	3	2	1	0	
Access : POR								W : XX	
Bit Name								Data[7:0]	

This register is one of two multiplicand registers for the signed 8-bit multiplier in the PSoC MAC.

This register is for 2 MAC block PSoC devices only. For additional information, refer to the “[Register Definitions](#)” on page 470 in the Multiply Accumulate chapter.

Bit	Name	Description
7:0	Data[7:0]	Y multiplicand for MAC 8-bit multiplier.

13.2.53 MULx_DH

Multiply Result High Byte Register

Individual Register Names and Addresses:

MUL1_DH : 0,AAh MUL0_DH : 0,EAh

	7	6	5	4	3	2	1	0
Access : POR	R : XX							
Bit Name	Data[7:0]							

This register holds the most significant byte of the 16-bit product.

This register is for 2 MAC block PSoC devices only. For additional information, refer to the “[Register Definitions](#)” on page 470 in the Multiply Accumulate chapter.

Bit	Name	Description
7:0	Data[7:0]	High byte of MAC multiplier 16-bit product.

13.2.54 MULx_DL

Multiply Result Low Byte Register

Individual Register Names and Addresses:

MUL1_DL : 0,ABh MUL0_DL : 0,EBh

	7	6	5	4	3	2	1	0
Access : POR	R : XX							
Bit Name	Data[7:0]							

This register holds the least significant byte of the 16-bit product.

This register is for 2 MAC block PSoC devices only. For additional information, refer to the [“Register Definitions” on page 470](#) in the Multiply Accumulate chapter.

Bit	Name	Description
7:0	Data[7:0]	Low byte of MAC multiplier 16-bit product.

0,ACh

13.2.55 MACx_X/ACCx_DR1

Accumulator Data Register 1

Individual Register Names and Addresses:

MAC1_X/ACC1_DR1 : 0,ACh MAC0_X/ACC0_DR1 : 0,ECh

	7	6	5	4	3	2	1	0
Access : POR	RW : 00							
Bit Name	Data[7:0]							

This is the multiply accumulate X register and the second byte of the accumulated value.

This register is for 2 MAC block PSoC devices only. For additional information, refer to the [“Register Definitions” on page 470](#) in the Multiply Accumulate chapter.

Bit	Name	Description	
7:0	Data[7:0]	Read	Returns the 2nd byte of the 32-bit accumulated value. The 2nd byte is next to the least significant byte for the accumulated value.
		Write	X multiplicand for the MAC 16-bit multiply and 32-bit accumulator.

13.2.56 MACx_Y/ACCx_DR0

Accumulator Data Register 0

Individual Register Names and Addresses:

MAC1_Y/ACC1_DR0 : 0,ADh MAC0_Y/ACC0_DR0 : 0,EDh

	7	6	5	4	3	2	1	0	
Access : POR								RW : 00	
Bit Name								Data[7:0]	

This is the multiply accumulate Y register and the first byte of the accumulated value.

This register is for 2 MAC block PSoC devices only. For additional information, refer to the “[Register Definitions](#)” on page 470 in the Multiply Accumulate chapter.

Bit	Name	Description	
7:0	Data[7:0]	Read	Returns the 1st byte of the 32-bit accumulated value. The 1st byte is the least significant byte for the accumulated value.
		Write	Y multiplicand for the MAC 16-bit multiply and 32-bit accumulate.

0,AEh

13.2.57 MACx_CL0/ACCx_DR3

Accumulator Data Register 3

Individual Register Names and Addresses:

MAC1_CL0/ACC1_DR3 : 0,AEh MAC0_CL0/ACC0_DR3 : 0,EEh

	7	6	5	4	3	2	1	0
Access : POR	RW : 00							
Bit Name	Data[7:0]							

This is an accumulator clear register and the fourth byte of the accumulated value.

This register is for 2 MAC block PSoC devices only. For additional information, refer to the “[Register Definitions](#)” on page 470 in the Multiply Accumulate chapter.

Bit	Name	Description
7:0	Data[7:0]	<p>Read Returns the 4th byte of the 32-bit accumulated value. The 4th byte is the most significant byte (MSB) for the accumulated value.</p> <p>Write Writing any value to this address will clear all four bytes of the Accumulator.</p>

13.2.58 MACx_CL1/ACCx_DR2

Accumulator Data Register 2

Individual Register Names and Addresses:

MAC1_CL1/ACC1_DR2 : 0,AFh MAC0_CL1/ACC0_DR2 : 0,EFh

	7	6	5	4	3	2	1	0	
Access : POR								RW : 00	
Bit Name								Data[7:0]	

This is an accumulator clear register and the third byte of the accumulated value.

This register is for 2 MAC block PSoC devices only. For additional information, refer to the “[Register Definitions](#)” on page 470 in the Multiply Accumulate chapter.

Bit	Name	Description	
7:0	Data[7:0]	Read	Returns the 3rd byte of the 32-bit accumulated value. The 3rd byte is the next to most significant byte for the accumulated value.
		Write	Writing any value to this address will clear all four bytes of the Accumulator.

13.2.59 RDIXRI

Row Digital Interconnect Row Input Register

Individual Register Names and Addresses:

RD10RI : x,B0h RD11RI : x,B8h RD12RI : x,C0h RD13RI : x,C8h

	7	6	5	4	3	2	1	0
Access : POR	RW : 0		RW : 0		RW : 0		RW : 0	
Bit Name	RI3[1:0]		RI2[1:0]		RI1[1:0]		RI0[1:0]	

This register is used to control the input mux that determines which global inputs will drive the row inputs.

The 'x' in the digital register's name represents the digital row index. Depending on the digital row characteristics of your PSoC device (see the table titled "PSoC Device Characteristics" on page 307), some addresses may not be available. For additional information, refer to the "Register Definitions" on page 329 in the Row Digital Interconnect chapter.

Bit	Name	Description
7:6	RI3[1:0]	Select source for row input 3. 00b GIE[3] 01b GIE[7] 10b GIO[3] 11b GIO[7]
5:4	RI2[1:0]	Select source for row input 2. 00b GIE[2] 01b GIE[6] 10b GIO[2] 11b GIO[6]
3:2	RI1[1:0]	Select source for row input 1. 00b GIE[1] 01b GIE[5] 10b GIO[1] 11b GIO[5]
1:0	RI0[1:0]	Select source for row input 0. 00b GIE[0] 01b GIE[4] 10b GIO[0] 11b GIO[4]

13.2.60 RDixSYN

Row Digital Interconnect Synchronization Register

Individual Register Names and Addresses:

RDIOSYN : x,B1h

RDI1SYN : x,B9h

RDI2SYN : x,C1h

RDI3SYN : x,C9h

	7	6	5	4	3	2	1	0
Access : POR					RW : 0	RW : 0	RW : 0	RW : 0
Bit Name					RI3SYN	RI2SYN	RI1SYN	RIOSYN

This register is used to control the input synchronization.

The 'x' in the digital register's name represents the digital row index. Depending on the digital row characteristics of your PSoC device (see the table titled "PSoC Device Characteristics" on page 307), some addresses may not be available. In the table above, note that reserved bits are grayed table cells and are not described in the bit description section below. Reserved bits should always be written with a value of '0'. For additional information, refer to the "Register Definitions" on page 329 in the Row Digital Interconnect chapter.

Bit	Name	Description	
3	RI3SYN	0	Row input 3 is synchronized to the SYSCLK system clock.
		1	Row input 3 is passed without synchronization.
2	RI2SYN	0	Row input 2 is synchronized to the SYSCLK system clock.
		1	Row input 2 is passed without synchronization.
1	RI1SYN	0	Row input 1 is synchronized to the SYSCLK system clock.
		1	Row input 1 is passed without synchronization.
0	RIOSYN	0	Row input 0 is synchronized to the SYSCLK system clock.
		1	Row input 0 is passed without synchronization.

13.2.61 RDIXIS

Row Digital Interconnect Input Select Register

Individual Register Names and Addresses:

RDIXIS : x,B2h RDI1IS : x,BAh RDI2IS : x,C2h RDI3IS : x,CAh

	7	6	5	4	3	2	1	0
Access : POR			RW : 0	RW : 0	RW : 0	RW : 0	RW : 0	RW : 0
Bit Name			BCSEL[1:0]	IS3	IS2	IS1	IS0	IS0

This register is used to configure the inputs to the digital row LUTS and select a broadcast driver from another row if present. The 'x' in the digital register's name represents the digital row index. Depending on the digital row characteristics of your PSoC device (see the table titled "PSoC Device Characteristics" on page 307), some addresses may not be available. In the table above, note that reserved bits are grayed table cells and are not described in the bit description section below. Reserved bits should always be written with a value of '0'. For additional information, refer to the "Register Definitions" on page 329 in the Row Digital Interconnect chapter.

Bit	Name	Description
5:4	BCSEL[1:0]	<p>When the BCSEL value is equal to the row number, the tri-state buffer that drives the row broadcast net from the input select mux is disabled, so that one of the row's blocks may drive the local row broadcast net.</p> <p>00b Row 0 drives row broadcast net. 01b Row 1 drives row broadcast net. Reserved for 1 row PSoC devices. 10b Row 2 drives row broadcast net. Reserved for 1 and 2 row PSoC devices. 11b Row 3 drives row broadcast net. Reserved for 1, 2, and 3 row PSoC devices.</p>
3	IS3	<p>0 The 'A' input of LUT3 is RO[3]. 1 The 'A' input of LUT3 is RI[3].</p>
2	IS2	<p>0 The 'A' input of LUT2 is RO[2]. 1 The 'A' input of LUT2 is RI[2].</p>
1	IS1	<p>0 The 'A' input of LUT1 is RO[1]. 1 The 'A' input of LUT1 is RI[1].</p>
0	IS0	<p>0 The 'A' input of LUT0 is RO[0]. 1 The 'A' input of LUT0 is RI[0].</p>

13.2.62 RDlxLT0

Row Digital Interconnect Logic Table Register 0

Individual Register Names and Addresses:

RDl0LT0 : x,B3h

RDl1LT0 : x,BBh

RDl2LT0 : x,C3h

RDl3LT0 : x,CBh

	7	6	5	4	3	2	1	0
Access : POR	RW : 0				RW : 0			
Bit Name	LUT1[3:0]				LUT0[3:0]			

This register is used to select the logic function of the digital row LUTS.

The 'x' in the digital register's name represents the digital row index. Depending on the digital row characteristics of your PSoC device (see the table titled "PSoC Device Characteristics" on page 307), some addresses may not be available. For additional information, refer to the "Register Definitions" on page 329 in the Row Digital Interconnect chapter.

Bit	Name	Description
7:4	LUT1[3:0]	Select logic function for LUT1. Function 0h FALSE 1h A AND B 2h A AND \bar{B} 3h A 4h \bar{A} AND B 5h B 6h A XOR B 7h A OR B 8h A NOR B 9h \bar{A} XNOR B Ah \bar{B} Bh \bar{A} OR \bar{B} Ch \bar{A} Dh \bar{A} OR B Eh A NAND B Fh TRUE
3:0	LUT0[3:0]	Select logic function for LUT0. Function 0h FALSE 1h A AND B 2h A AND \bar{B} 3h A 4h \bar{A} AND B 5h B 6h A XOR B 7h A OR B 8h A NOR B 9h \bar{A} XNOR B Ah \bar{B} Bh \bar{A} OR \bar{B} Ch \bar{A} Dh \bar{A} OR B Eh A NAND B Fh TRUE

13.2.63 RDixLT1

Row Digital Interconnect Logic Table Register 1

Individual Register Names and Addresses:

RD10LT1 :x,B4h RD11LT1 :x,BCh RD12LT1 :x,C4h RD13LT1 :x,CCh

	7	6	5	4	3	2	1	0
Access : POR	RW : 0				RW : 0			
Bit Name	LUT3[3:0]				LUT2[3:0]			

This register is used to select the logic function of the digital row LUTS.

The 'x' in the digital register's name represents the digital row index. Depending on the digital row characteristics of your PSoC device (see the table titled "PSoC Device Characteristics" on page 307), some addresses may not be available. For additional information, refer to the "Register Definitions" on page 329 in the Row Digital Interconnect chapter.

Bit	Name	Description
7:4	LUT3[3:0]	Select logic function for LUT3. <div style="margin-left: 20px;"> Function 0h FALSE 1h A AND B 2h A AND \bar{B} 3h \bar{A} 4h \bar{A} AND B 5h B 6h A XOR B 7h A OR B 8h A NOR B 9h A XNOR B Ah \bar{B} Bh \bar{A} OR \bar{B} Ch \bar{A} Dh \bar{A} OR B Eh A NAND B Fh TRUE </div>
3:0	LUT2[3:0]	Select logic function for LUT2. <div style="margin-left: 20px;"> Function 0h FALSE 1h A AND \bar{B} 2h A AND B 3h \bar{A} 4h \bar{A} AND B 5h B 6h A XOR B 7h A OR B 8h A NOR B 9h A XNOR B Ah \bar{B} Bh \bar{A} OR \bar{B} Ch \bar{A} Dh \bar{A} OR B Eh A NAND B Fh TRUE </div>

13.2.64 RDixRO0

Row Digital Interconnect Row Output Register 0

Individual Register Names and Addresses:

RDI0RO0 : x,B5h

RDI1RO0 : x,BDh

RDI2RO0 : x,C5h

RDI3RO0 : x,CDh

	7	6	5	4	3	2	1	0
Access : POR	RW : 0	RW : 0	RW : 0	RW : 0	RW : 0	RW : 0	RW : 0	RW : 0
Bit Name	GOO5EN	GOO1EN	GOE5EN	GOE1EN	GOO4EN	GOO0EN	GOE4EN	GOE0EN

This register is used to select the global nets that the row outputs drive.

The 'x' in the digital register's name represents the digital row index. Depending on the digital row characteristics of your PSoC device (see the table titled "PSoC Device Characteristics" on page 307), some addresses may not be available. For additional information, refer to the "Register Definitions" on page 329 in the Row Digital Interconnect chapter.

Bit	Name	Description
7	GOO5EN	0 Disable Row's LUT1 output to global output.
		1 Enable Row's LUT1 output to GOO[5].
6	GOO1EN	0 Disable Row's LUT1 output to global output.
		1 Enable Row's LUT1 output to GOO[1].
5	GOE5EN	0 Disable Row's LUT1 output to global output.
		1 Enable Row's LUT1 output to GOE[5].
4	GOE1EN	0 Disable Row's LUT1 output to global output.
		1 Enable Row's LUT1 output to GOE[1].
3	GOO4EN	0 Disable Row's LUT0 output to global output.
		1 Enable Row's LUT0 output to GOO[4].
2	GOO0EN	0 Disable Row's LUT0 output to global output.
		1 Enable Row's LUT0 output to GOO[0].
1	GOE4EN	0 Disable Row's LUT0 output to global output.
		1 Enable Row's LUT0 output to GOE[4].
0	GOE0EN	0 Disable Row's LUT0 output to global output.
		1 Enable Row's LUT0 output to GOE[0].

13.2.65 RDIxRO1

Row Digital Interconnect Row Output Register 1

Individual Register Names and Addresses:

RDI0RO1 : x,B6h

RDI1RO1 : x,BEh

RDI2RO1 : x,C6h

RDI3RO1 : x,CEh

	7	6	5	4	3	2	1	0
Access : POR	RW : 0	RW : 0	RW : 0	RW : 0	RW : 0	RW : 0	RW : 0	RW : 0
Bit Name	GOO7EN	GOO3EN	GOE7EN	GOE3EN	GOO6EN	GOO2EN	GOE6EN	GOE2EN

This register is used to select the global nets that the row outputs drive.

The 'x' in the digital register's name represents the digital row index. Depending on the digital row characteristics of your PSoC device (see the table titled "PSoC Device Characteristics" on page 307), some addresses may not be available. For additional information, refer to the "Register Definitions" on page 329 in the Row Digital Interconnect chapter.

Bit	Name	Description
7	GOO7EN	0 Disable Row's LUT3 output to global output.
		1 Enable Row's LUT3 output to GOO[7].
6	GOO3EN	0 Disable Row's LUT3 output to global output.
		1 Enable Row's LUT3 output to GOO[3].
5	GOE7EN	0 Disable Row's LUT3 output to global output.
		1 Enable Row's LUT3 output to GOE[7].
4	GOE3EN	0 Disable Row's LUT3 output to global output.
		1 Enable Row's LUT3 output to GOE[3].
3	GOO6EN	0 Disable Row's LUT2 output to global output.
		1 Enable Row's LUT2 output to GOO[6].
2	GOO2EN	0 Disable Row's LUT2 output to global output.
		1 Enable Row's LUT2 output to GOO[2].
1	GOE6EN	0 Disable Row's LUT2 output to global output.
		1 Enable Row's LUT2 output to GOE[6].
0	GOE2EN	0 Disable Row's LUT2 output to global output.
		1 Enable Row's LUT2 output to GOE[2].

13.2.66 CUR_PP

Current Page Pointer Register

Individual Register Names and Addresses:

CUR_PP: 0,D0h

	7	6	5	4	3	2	1	0
Access : POR						RW : 0		
Bit Name						Page Bits[2:0]		

This register is used to set the effective SRAM page for normal memory accesses in a multi-SRAM page PSoC device.

This register is only used when a device has more than one page of SRAM, see the table titled “PSoC Device SRAM Availability” on page 85. In the table above, note that reserved bits are grayed table cells and are not described in the bit description section below. Reserved bits should always be written with a value of ‘0’. For additional information, refer to the “Register Definitions” on page 89 in the RAM Paging chapter.

Bit	Name	Description
2:0	Page Bits[2:0]	These bits determine which SRAM Page is used for generic SRAM access. See the RAM Paging chapter on page 85 for more information.
		000b SRAM Page 0
		001b SRAM Page 1
		010b SRAM Page 2
		011b SRAM Page 3
		100b SRAM Page 4
		101b SRAM Page 5
		110b SRAM Page 6
		111b SRAM Page 7

Note A value beyond the available SRAM, for a specific PSoC device, should not be set.

0,D1h

13.2.67 STK_PP

Stack Page Pointer Register

Individual Register Names and Addresses:

STK_PP: 0,D1h

	7	6	5	4	3	2	1	0
Access : POR								RW : 0
Bit Name								Page Bits[2:0]

This register is used to set the effective SRAM page for stack memory accesses in a multi-SRAM page PSoC device.

This register is only used when a device has more than one page of SRAM, see the table titled “PSoC Device SRAM Availability” on page 85. In the table above, note that reserved bits are grayed table cells and are not described in the bit description section below. Reserved bits should always be written with a value of ‘0’. For additional information, refer to the “Register Definitions” on page 89 in the RAM Paging chapter.

Bit	Name	Description
2:0	Page Bits[2:0]	These bits determine which SRAM Page is used to hold the stack. See the RAM Paging chapter on page 85 for more information.
	000b	SRAM Page 0
	001b	SRAM Page 1
	010b	SRAM Page 2
	011b	SRAM Page 3
	100b	SRAM Page 4
	101b	SRAM Page 5
	110b	SRAM Page 6
	111b	SRAM Page 7

Note A value beyond the available SRAM, for a specific PSoC device, should not be set.

13.2.68 IDX_PP

Indexed Memory Access Page Pointer Register

Individual Register Names and Addresses:

IDX_PP: 0,D3h

	7	6	5	4	3	2	1	0
Access : POR						RW : 0		
Bit Name						Page Bits[2:0]		

This register is used to set the effective SRAM page for indexed memory accesses in a multi-SRAM page PSoC device.

This register is only used when a device has more than one page of SRAM, see the table titled “PSoC Device SRAM Availability” on page 85. In the table above, note that reserved bits are grayed table cells and are not described in the bit description section below. Reserved bits should always be written with a value of ‘0’. For additional information, refer to the “Register Definitions” on page 89 in the RAM Paging chapter.

Bit	Name	Description
2:0	Page Bits[2:0]	<p>These bits determine which SRAM Page an indexed memory access operates on. See the “Register Definitions” on page 89 for more information on when this register is active.</p> <p>000b SRAM Page 0 001b SRAM Page 1 010b SRAM Page 2 011b SRAM Page 3 100b SRAM Page 4 101b SRAM Page 5 110b SRAM Page 6 111b SRAM Page 7</p>

Note A value beyond the available SRAM, for a specific PSoC device, should not be set.

13.2.69 MVR_PP

MVI Read Page Pointer Register

Individual Register Names and Addresses:

MVR_PP: 0,D4h

	7	6	5	4	3	2	1	0
Access : POR							RW : 0	
Bit Name							Page Bits[2:0]	

This register is used to set the effective SRAM page for MVI read memory accesses in a multi-SRAM page PSoC device.

This register is only used when a device has more than one page of SRAM, see the table titled “PSoC Device SRAM Availability” on page 85. In the table above, note that reserved bits are grayed table cells and are not described in the bit description section below. Reserved bits should always be written with a value of ‘0’. For additional information, refer to the “Register Definitions” on page 89 in the RAM Paging chapter.

Bit	Name	Description
2:0	Page Bits[2:0]	These bits determine which SRAM Page a MVI Read instruction operates on.
		000b SRAM Page 0
		001b SRAM Page 1
		010b SRAM Page 2
		011b SRAM Page 3
		100b SRAM Page 4
		101b SRAM Page 5
		110b SRAM Page 6
		111b SRAM Page 7

Note A value beyond the available SRAM, for a specific PSoC device, should not be set.

13.2.70 MVW_PP

MVI Write Page Pointer Register

Individual Register Names and Addresses:

MVW_PP: 0,D5h

	7	6	5	4	3	2	1	0
Access : POR						RW : 0		
Bit Name						Page Bits[2:0]		

This register is used to set the effective SRAM page for MVI write memory accesses in a multi-SRAM page PSoC device.

This register is only used when a device has more than one page of SRAM, see the table titled “PSoC Device SRAM Availability” on page 85. In the table above, note that reserved bits are grayed table cells and are not described in the bit description section below. Reserved bits should always be written with a value of ‘0’. For additional information, refer to the “Register Definitions” on page 89 in the RAM Paging chapter.

Bit	Name	Description
2:0	Page Bits[2:0]	<p>These bits determine which SRAM Page a MVI Write instruction operates on.</p> <p>000b SRAM Page 0</p> <p>001b SRAM Page 1</p> <p>010b SRAM Page 2</p> <p>011b SRAM Page 3</p> <p>100b SRAM Page 4</p> <p>101b SRAM Page 5</p> <p>110b SRAM Page 6</p> <p>111b SRAM Page 7</p> <p>Note A value beyond the available SRAM, for a specific PSoC device, should not be set.</p>

13.2.71 I2C_CFG

I²C Configuration Register

Individual Register Names and Addresses:

I2C_CFG: 0,D6h

	7	6	5	4	3	2	1	0
Access : POR		RW : 0	RW : 0	RW : 0	RW : 0		RW : 0	RW : 0
Bit Name		PSelect	Bus Error IE	Stop IE	Clock Rate[1:0]		Enable Master	Enable Slave

This register is used to set the basic operating modes, baud rate, and selection of interrupts.

In the table above, note that reserved bits are grayed table cells and are not described in the bit description section below. Reserved bits should always be written with a value of '0'. For additional information, refer to the “[Register Definitions](#)” on [page 486](#) in the I2C chapter.

Bit	Name	Description
6	PSelect	I2C Pin Select 0 P1[5] and P1[7] 1 P1[0] and P1[1] Note Read the I2C chapter for a discussion of the side effects of choosing the P1[0] and P1[1] pair of pins.
5	Bus Error IE	Bus Error Interrupt Enable 0 Disabled 1 Enabled. An interrupt is generated on the detection of a Bus Error.
4	Stop IE	Stop Interrupt Enable 0 Disabled 1 Enabled. An interrupt is generated on the detection of a Stop Condition.
3:2	Clock Rate[1:0]	00b 100K Standard Mode 01b 400K Fast Mode 10b 50K Standard Mode 11b Reserved
1	Enable Master	Writing a '0' to both the Enable Master and Enable Slave bits will hold the I2C hardware in reset. 0 Disabled 1 Enabled
0	Enable Slave	Writing a '0' to both the Enable Master and Enable Slave bits will hold the I2C hardware in reset. 0 Disabled 1 Enabled

13.2.72 I2C_SCR

I²C Status and Control Register

Individual Register Names and Addresses:

I2C_SCR: 0,D7h

	7	6	5	4	3	2	1	0
Access : POR	RC : 0	RC : 0	RC : 0	RW : 0	RC : 0	RW : 0	RC : 0	RC : 0
Bit Name	Bus Error	Lost Arb	Stop Status	ACK	Address	Transmit	LRB	Byte Complete

This register is used by both master and slave to control the flow of data bytes and to keep track of the bus state during a transfer.

Bits in this register are held in reset until one of the enable bits in I2C_CFG is set. For additional information, refer to the “[Register Definitions](#)” on page 486 in the I2C chapter.

Bit	Name	Description
7	Bus Error	0 This status bit must be cleared by firmware by writing a ‘0’ to the bit position. It is never cleared by the hardware.
		1 A misplaced Start or Stop condition was detected.
6	Lost Arb	0 This bit is set immediately on lost arbitration; however, it does not cause an interrupt. This status may be checked after the following Byte Complete interrupt. Any Start detect or a write to the Start or Restart generate bits (I2C_MSCR register), when operating in Master mode, will also clear the bit.
		1 Lost Arbitration
5	Stop Status	0 This status bit must be cleared by firmware with write of ‘0’ to the bit position. It is never cleared by the hardware.
		1 A Stop condition was detected.
4	ACK	Acknowledge Out. This bit is automatically cleared by hardware on a Byte Complete event.
		0 NACK the last received byte. 1 ACK the last received byte
3	Address	0 This status bit must be cleared by firmware with write of ‘0’ to the bit position.
		1 The received byte is a slave address.
2	Transmit	Transmit bit is set by firmware to define the direction of the byte transfer. Any Start detect or a write to the Start or Restart generate bits, when operating in Master mode, will also clear the bit.
		0 Receive mode 1 Transmit mode
1	LRB	Last Received Bit. The value of the 9 th bit in a Transmit sequence, which is the acknowledge bit from the receiver. Any Start detect or a write to the Start or Restart generate bits, when operating in Master mode, will also clear the bit.
		0 Last transmitted byte was ACK’ed by the receiver. 1 Last transmitted byte was NACK’ed by the receiver.

(continued on next page)

13.2.72 I2C_SCR (continued)

0 Byte Complete

Transmit/Receive Mode:

0 No completed transmit/receive since last cleared by firmware. Any Start detect or a write to the Start or Restart generate bits, when operating in Master mode, will also clear the bit.

Transmit Mode:

1 Eight bits of data have been transmitted and an ACK or NACK has been received.

Receive Mode:

1 Eight bits of data have been received.

13.2.73 I2C_DR

I²C Data Register

Individual Register Names and Addresses:

I2C_DR: 0,D8h

	7	6	5	4	3	2	1	0	
Access : POR								RW : 00	
Bit Name								Data[7:0]	

This register provides read/write access to the Shift register.

This register is read only for received data and write only for transmitted data. For additional information, refer to the “Register Definitions” on page 486 in the I2C chapter.

Bit	Name	Description
7:0	Data[7:0]	Read received data or write data to transmit.

13.2.74 I2C_MSCR

I²C Master Status and Control Register

Individual Register Names and Addresses:

I2C_MSCR: 0,D9h

	7	6	5	4	3	2	1	0
Access : POR					R : 0	R : 0	RW : 0	RW : 0
Bit Name					Bus Busy	Master Mode	Restart Gen	Start Gen

This register implements I2C framing controls and provides Bus Busy status.

Bits in this register are held in reset until one of the enable bits in I2C_CFG is set. In the table above, note that reserved bits are grayed table cells and are not described in the bit description section below. Reserved bits should always be written with a value of '0'. For additional information, refer to the [“Register Definitions” on page 486](#) in the I2C chapter.

Bit	Name	Description
3	Bus Busy	This bit is set to the following. 0 When a Stop condition is detected (from any bus master). 1 When a Start condition is detected (from any bus master).
2	Master Mode	This bit is set/cleared by hardware when the device is operating as a master. 0 Stop condition detected, generated by this device. 1 Start condition detected, generated by this device.
1	Restart Gen	This bit is cleared by hardware when the Restart generation is complete. 0 Restart generation complete. 1 Generate a Restart condition.
0	Start Gen	This bit is cleared by hardware when the Start generation is complete. 0 Start generation complete. 1 Generate a Start condition and send a byte (address) to the I2C bus, if bus is not busy.

13.2.75 INT_CLR0

Interrupt Clear Register 0

Individual Register Names and Addresses:

INT_CLR0: 0,DAh

4 COLUMN	7	6	5	4	3	2	1	0
Access : POR	RW : 0	RW : 0	RW : 0	RW : 0	RW : 0	RW : 0	RW : 0	RW : 0
Bit Name	VC3	Sleep	GPIO	Analog 3	Analog 2	Analog 1	Analog 0	V Monitor

2 COLUMN	7	6	5	4	3	2	1	0
Access : POR	RW : 0	RW : 0	RW : 0			RW : 0	RW : 0	RW : 0
Bit Name	VC3	Sleep	GPIO			Analog 1	Analog 0	V Monitor

1 COLUMN	7	6	5	4	3	2	1	0
Access : POR	RW : 0	RW : 0	RW : 0			RW : 0		RW : 0
Bit Name	VC3	Sleep	GPIO			Analog 1		V Monitor

This register is used to enable the individual interrupt sources' ability to clear posted interrupts.

When bits in this register are read, a '1' will be returned for every bit position that has a corresponding posted interrupt. When bits in this register are written with a '0' and ENSWINT is not set, posted interrupts will be cleared at the corresponding bit positions. If there was not a posted interrupt, there is no effect. When bits in this register are written with a '1' and ENSWINT is set, an interrupt is posted in the interrupt controller. Note that the ENSWINT bit is in the [INT_MSK3 register on page 236](#).

Use the register tables above, in addition to the detailed register bit descriptions below, to determine which bits are reserved for some smaller PSoC devices. Note that reserved bits are grayed table cells and are not described in the bit description section. Reserved bits should always be written with a value of '0'. For additional information, refer to the ["Register Definitions" on page 98](#) in the Interrupt Controller chapter.

Bit	Name	Description
7	VC3	Read 0 No posted interrupt for Variable Clock 3. Read 1 Posted interrupt present for Variable Clock 3. Write 0 AND ENSWINT = 0 Clear posted interrupt if it exists. Write 1 AND ENSWINT = 0 No effect. Write 0 AND ENSWINT = 1 No effect. Write 1 AND ENSWINT = 1 Post an interrupt for Variable Clock 3.
6	Sleep	Read 0 No posted interrupt for sleep timer. Read 1 Posted interrupt present for sleep timer. Write 0 AND ENSWINT = 0 Clear posted interrupt if it exists. Write 1 AND ENSWINT = 0 No effect. Write 0 AND ENSWINT = 1 No effect. Write 1 AND ENSWINT = 1 Post an interrupt for sleep timer.
5	GPIO	Read 0 No posted interrupt for general purpose inputs and outputs (pins). Read 1 Posted interrupt present for GPIO (pins). Write 0 AND ENSWINT = 0 Clear posted interrupt if it exists. Write 1 AND ENSWINT = 0 No effect. Write 0 AND ENSWINT = 1 No effect. Write 1 AND ENSWINT = 1 Post an interrupt for general purpose inputs and outputs (pins).

(continued on next page)

13.2.75 INT_CLR0 (continued)

4	Analog 3	Read 0	No posted interrupt for analog columns.
		Read 1	Posted interrupt present for analog columns
		Write 0 AND ENSWINT = 0	Clear posted interrupt if it exists.
		Write 1 AND ENSWINT = 0	No effect.
		Write 0 AND ENSWINT = 1	No effect.
		Write 1 AND ENSWINT = 1	Post an interrupt for analog columns.
3	Analog 2	Read 0	No posted interrupt for analog columns.
		Read 1	Posted interrupt present for analog columns
		Write 0 AND ENSWINT = 0	Clear posted interrupt if it exists.
		Write 1 AND ENSWINT = 0	No effect.
		Write 0 AND ENSWINT = 1	No effect.
		Write 1 AND ENSWINT = 1	Post an interrupt for analog columns.
2	Analog 1	Read 0	No posted interrupt for analog columns.
		Read 1	Posted interrupt present for analog columns
		Write 0 AND ENSWINT = 0	Clear posted interrupt if it exists.
		Write 1 AND ENSWINT = 0	No effect.
		Write 0 AND ENSWINT = 1	No effect.
		Write 1 AND ENSWINT = 1	Post an interrupt for analog columns.
1	Analog 0	Read 0	No posted interrupt for analog columns.
		Read 1	Posted interrupt present for analog columns
		Write 0 AND ENSWINT = 0	Clear posted interrupt if it exists.
		Write 1 AND ENSWINT = 0	No effect.
		Write 0 AND ENSWINT = 1	No effect.
		Write 1 AND ENSWINT = 1	Post an interrupt for analog columns.
0	V Monitor	Read 0	No posted interrupt for supply voltage monitor.
		Read 1	Posted interrupt present for supply voltage monitor.
		Write 0 AND ENSWINT = 0	Clear posted interrupt if it exists.
		Write 1 AND ENSWINT = 0	No effect.
		Write 0 AND ENSWINT = 1	No effect.
		Write 1 AND ENSWINT = 1	Post an interrupt for supply voltage monitor.

13.2.76 INT_CLR1

Interrupt Clear Register 1

Individual Register Names and Addresses:

INT_CLR1: 0,DBh

4, 2 Rows	7	6	5	4	3	2	1	0
Access : POR	RW : 0	RW : 0	RW : 0	RW : 0	RW : 0	RW : 0	RW : 0	RW : 0
Bit Name	DCB13	DCB12	DBB11	DBB10	DCB03	DCB02	DBB01	DBB00

1 Row	7	6	5	4	3	2	1	0
Access : POR					RW : 0	RW : 0	RW : 0	RW : 0
Bit Name					DCB03	DCB02	DBB01	DBB00

This register is used to clear posted interrupts for digital blocks or generate interrupts.

When bits in this register are read, a '1' will be returned for every bit position that has a corresponding posted interrupt. When bits in this register are written with a '0' and ENSWINT is not set, posted interrupts will be cleared at the corresponding bit positions. If there was not a posted interrupt, there is no effect. When bits in this register are written with a '1' and ENSWINT is set, an interrupt is posted in the interrupt controller. Note that the ENSWINT bit is in the [INT_MSK3 register on page 236](#).

Use the register tables above, in addition to the detailed register bit descriptions below, to determine which bits are reserved for some smaller PSoC devices. Note that reserved bits are grayed table cells and are not described in the bit description section. Reserved bits should always be written with a value of '0'. For additional information, refer to the "Register Definitions" on [page 98](#) in the Interrupt Controller chapter.

Bit	Name	Description
7	DCB13	Digital Communications Block type B, row 1, position 3. Read 0 No posted interrupt. Read 1 Posted interrupt present. Write 0 AND ENSWINT = 0 Clear posted interrupt if it exists. Write 1 AND ENSWINT = 0 No effect. Write 0 AND ENSWINT = 1 No effect. Write 1 AND ENSWINT = 1 Post an interrupt.
6	DCB12	Digital Communications Block type B, row 1, position 2. Read 0 No posted interrupt. Read 1 Posted interrupt present. Write 0 AND ENSWINT = 0 Clear posted interrupt if it exists. Write 1 AND ENSWINT = 0 No effect. Write 0 AND ENSWINT = 1 No effect. Write 1 AND ENSWINT = 1 Post an interrupt.
5	DBB11	Digital Basic Block type B, row 1, position 1. Read 0 No posted interrupt. Read 1 Posted interrupt present. Write 0 AND ENSWINT = 0 Clear posted interrupt if it exists. Write 1 AND ENSWINT = 0 No effect. Write 0 AND ENSWINT = 1 No effect. Write 1 AND ENSWINT = 1 Post an interrupt.

(continued on next page)

13.2.76 INT_CLR1 (continued)

4	DBB10	<p>Digital Basic Block type B, row 1, position 0.</p> <p>Read 0 No posted interrupt. Read 1 Posted interrupt present. Write 0 AND ENSWINT = 0 Clear posted interrupt if it exists. Write 1 AND ENSWINT = 0 No effect. Write 0 AND ENSWINT = 1 No effect. Write 1 AND ENSWINT = 1 Post an interrupt.</p>
3	DCB03	<p>Digital Communications Block type B, row 0, position 3.</p> <p>Read 0 No posted interrupt. Read 1 Posted interrupt present. Write 0 AND ENSWINT = 0 Clear posted interrupt if it exists. Write 1 AND ENSWINT = 0 No effect. Write 0 AND ENSWINT = 1 No effect. Write 1 AND ENSWINT = 1 Post an interrupt.</p>
2	DCB02	<p>Digital Communications Block type B, row 0, position 2.</p> <p>Read 0 No posted interrupt. Read 1 Posted interrupt present. Write 0 AND ENSWINT = 0 Clear posted interrupt if it exists. Write 1 AND ENSWINT = 0 No effect. Write 0 AND ENSWINT = 1 No effect. Write 1 AND ENSWINT = 1 Post an interrupt.</p>
1	DBB01	<p>Digital Basic Block type B, row 0, position 1.</p> <p>Read 0 No posted interrupt. Read 1 Posted interrupt present. Write 0 AND ENSWINT = 0 Clear posted interrupt if it exists. Write 1 AND ENSWINT = 0 No effect. Write 0 AND ENSWINT = 1 No effect. Write 1 AND ENSWINT = 1 Post an interrupt.</p>
0	DBB00	<p>Digital Basic Block type B, row 0, position 0.</p> <p>Read 0 No posted interrupt. Read 1 Posted interrupt present. Write 0 AND ENSWINT = 0 Clear posted interrupt if it exists. Write 1 AND ENSWINT = 0 No effect. Write 0 AND ENSWINT = 1 No effect. Write 1 AND ENSWINT = 1 Post an interrupt.</p>

13.2.77 INT_CLR2

Interrupt Clear Register 2

Individual Register Names and Addresses:

INT_CLR2: 0,DCh

	7	6	5	4	3	2	1	0
Access : POR	RW : 0	RW : 0	RW : 0	RW : 0	RW : 0	RW : 0	RW : 0	RW : 0
Bit Name	DCB33	DCB32	DBB31	DBB30	DCB23	DCB22	DBB21	DBB20
USB Bit Name	Wakeup Interrupt	Endpoint 4	Endpoint 3	Endpoint 2	Endpoint 1	Endpoint 0	Start of Frame	Bus Reset

This register is used to enable the individual interrupt sources' ability to clear posted interrupts for digital blocks.

This register is a dual purpose register: It is for 4 row digital PSoC devices and for the USB PSoC device (CY8C24x94 and CY7C64215). The USB device details are listed last in each bit description.

When bits in this register are read, a '1' will be returned for every bit position that has a corresponding posted interrupt. When bits in this register are written with a '0' and ENSWINT is not set, posted interrupts will be cleared at the corresponding bit positions. If there was not a posted interrupt, there is no effect. When bits in this register are written with a '1' and ENSWINT is set, an interrupt is posted in the interrupt controller. Note that the ENSWINT bit is in the [INT_MSK3 register on page 236](#). For additional information, refer to the ["Register Definitions" on page 98](#) in the Interrupt Controller chapter.

Bit	Name	Description
7	DCB33	Digital Communications Block type B, row 3, position 3. Read 0 No posted interrupt. Read 1 Posted interrupt present. Write 0 AND ENSWINT = 0 Clear posted interrupt if it exists. Write 1 AND ENSWINT = 0 No effect. Write 0 AND ENSWINT = 1 No effect. Write 1 AND ENSWINT = 1 Post an interrupt.
	Wakeup Interrupt	USB Wakeup Interrupt for the CY8C24x94 and CY7C64215.
6	DCB32	Digital Communications Block type B, row 3, position 2. Read 0 No posted interrupt. Read 1 Posted interrupt present. Write 0 AND ENSWINT = 0 Clear posted interrupt if it exists. Write 1 AND ENSWINT = 0 No effect. Write 0 AND ENSWINT = 1 No effect. Write 1 AND ENSWINT = 1 Post an interrupt.
	Endpoint 4	USB Endpoint 4 for the CY8C24x94 and CY7C64215.
5	DBB31	Digital Basic Block type B, row 3, position 1. Read 0 No posted interrupt. Read 1 Posted interrupt present. Write 0 AND ENSWINT = 0 Clear posted interrupt if it exists. Write 1 AND ENSWINT = 0 No effect. Write 0 AND ENSWINT = 1 No effect. Write 1 AND ENSWINT = 1 Post an interrupt.
	Endpoint 3	USB Endpoint 3 for the CY8C24x94 and CY7C64215.

(continued on next page)

13.2.77 INT_CLR2 (continued)

4	DBB30	<p>Digital Basic Block type B, row 3, position 0.</p> <p>Read 0 No posted interrupt. Read 1 Posted interrupt present. Write 0 AND ENSWINT = 0 Clear posted interrupt if it exists. Write 1 AND ENSWINT = 0 No effect. Write 0 AND ENSWINT = 1 No effect. Write 1 AND ENSWINT = 1 Post an interrupt.</p> <p>Endpoint 2 USB Endpoint 2 for the CY8C24x94 and CY7C64215.</p>
3	DCB23	<p>Digital Communications Block type B, row 2, position 3.</p> <p>Read 0 No posted interrupt. Read 1 Posted interrupt present. Write 0 AND ENSWINT = 0 Clear posted interrupt if it exists. Write 1 AND ENSWINT = 0 No effect. Write 0 AND ENSWINT = 1 No effect. Write 1 AND ENSWINT = 1 Post an interrupt.</p> <p>Endpoint 1 USB Endpoint 1 for the CY8C24x94 and CY7C64215.</p>
2	DCB22	<p>Digital Communications Block type B, row 2, position 2.</p> <p>Read 0 No posted interrupt. Read 1 Posted interrupt present. Write 0 AND ENSWINT = 0 Clear posted interrupt if it exists. Write 1 AND ENSWINT = 0 No effect. Write 0 AND ENSWINT = 1 No effect. Write 1 AND ENSWINT = 1 Post an interrupt.</p> <p>Endpoint 0 USB Endpoint 0 for the CY8C24x94 and CY7C64215.</p>
1	DBB21	<p>Digital Basic Block type B, row 2, position 1.</p> <p>Read 0 No posted interrupt. Read 1 Posted interrupt present. Write 0 AND ENSWINT = 0 Clear posted interrupt if it exists. Write 1 AND ENSWINT = 0 No effect. Write 0 AND ENSWINT = 1 No effect. Write 1 AND ENSWINT = 1 Post an interrupt.</p> <p>Start of Frame USB Start of Frame (SOF) for the CY8C24x94 and CY7C64215.</p>
0	DBB20	<p>Digital Basic Block type B, row 2, position 0.</p> <p>Read 0 No posted interrupt. Read 1 Posted interrupt present. Write 0 AND ENSWINT = 0 Clear posted interrupt if it exists. Write 1 AND ENSWINT = 0 No effect. Write 0 AND ENSWINT = 1 No effect. Write 1 AND ENSWINT = 1 Post an interrupt.</p> <p>Bus Reset USB Bus Reset for the CY8C24x94 and CY7C64215.</p>

13.2.78 INT_CLR3

Interrupt Clear Register 3

Individual Register Names and Addresses:

INT_CLR3: 0,DDh

	7	6	5	4	3	2	1	0
Access : POR								RW : 0
Bit Name								I2C

This register is used to enable the I2C interrupt sources' ability to clear posted interrupts.

When bits in this register are read, a '1' will be returned for every bit position that has a corresponding posted interrupt. When bits in this register are written with a '0' and ENSWINT is cleared, any posted interrupt will be cleared. If there was not a posted interrupt, there is no effect. When bits in this register are written with a '1' and ENSWINT is set, an interrupt is posted in the interrupt controller. In the table above, note that reserved bits are grayed table cells and are not described in the bit description section below. Reserved bits should always be written with a value of '0'. For additional information, refer to the "Register Definitions" on page 98 in the Interrupt Controller chapter.

Bit	Name	Description
0	I2C	Read 0 No posted interrupt for I2C. Read 1 Posted interrupt present for I2C. Write 0 AND ENSWINT = 0 Clear posted interrupt if it exists. Write 1 AND ENSWINT = 0 No effect. Write 0 AND ENSWINT = 1 No effect. Write 1 AND ENSWINT = 1 Post an interrupt for I2C.

13.2.79 INT_MSK3

Interrupt Mask Register 3

Individual Register Names and Addresses:

INT_MSK3: 0,DEh

	7	6	5	4	3	2	1	0
Access : POR	RW : 0							RW : 0
Bit Name	ENSWINT							I2C

This register is used to enable the I2C's ability to create pending interrupts and enable software interrupts.

When an interrupt is masked off, the mask bit is '0'. The interrupt will still post in the interrupt controller. Therefore, clearing the mask bit only prevents a posted interrupt from becoming a pending interrupt. In the table above, note that reserved bits are grayed table cells and are not described in the bit description section below. Reserved bits should always be written with a value of '0'. For additional information, refer to the ["Register Definitions"](#) on page 98 in the Interrupt Controller chapter.

Bit	Name	Description	
7	ENSWINT	0	Disable software interrupts.
		1	Enable software interrupts.
0	I2C	0	Mask I2C interrupt
		1	Unmask I2C interrupt

13.2.80 INT_MSK2

Interrupt Mask Register 2

Individual Register Names and Addresses:

INT_MSK2: 0,DFh

	7	6	5	4	3	2	1	0
Access : POR	RW : 0	RW : 0	RW : 0	RW : 0	RW : 0	RW : 0	RW : 0	RW : 0
Bit Name	DCB33	DCB32	DBB31	DBB30	DCB23	DCB22	DBB21	DBB20
USB Bit Name	Wakeup Interrupt	Endpoint 4	Endpoint 3	Endpoint 2	Endpoint 1	Endpoint 0	Start of Frame	Bus Reset

This register is used to enable the individual sources' ability to create pending interrupts for digital blocks.

This register is a dual purpose register: It is for 4 column analog PSoC devices and for the USB PSoC device (CY8C24x94 and CY7C64215). The USB device details are listed last in each bit description.

When an interrupt is masked off in this register, the mask bit is '0'. The interrupt will still post in the interrupt controller. Therefore, clearing the mask bit only prevents a posted interrupt from becoming a pending interrupt. For additional information, refer to the "Register Definitions" on page 98 in the Interrupt Controller chapter.

Bit	Name	Description
7	DCB33	0 Mask Digital Communication Block, row 3, position 3 interrupt.
		1 Unmask Digital Communication Block, row 3, position 3 interrupt.
	Wakeup Interrupt	USB Wakeup Interrupt for the CY8C24x94 and CY7C64215.
6	DCB32	0 Mask Digital Communication Block, row 3, position 2 interrupt.
		1 Unmask Digital Communication Block, row 3, position 2 interrupt.
	Endpoint 4	USB Endpoint 4 for the CY8C24x94 and CY7C64215.
5	DBB31	0 Mask Digital Basic Block, row 3, position 1 interrupt.
		1 Unmask Digital Basic Block, row 3, position 1 interrupt.
	Endpoint 3	USB Endpoint 3 for the CY8C24x94 and CY7C64215.
4	DBB30	0 Mask Digital Basic Block, row 3, position 0 interrupt.
		1 Unmask Digital Basic Block, row 3, position 0 interrupt.
	Endpoint 2	USB Endpoint 2 for the CY8C24x94 and CY7C64215.
3	DCB23	0 Mask Digital Communication Block, row 2, position 3 interrupt.
		1 Unmask Digital Communication Block, row 2, position 3 interrupt.
	Endpoint 1	USB Endpoint 1 for the CY8C24x94 and CY7C64215.
2	DCB22	0 Mask Digital Communication Block, row 2, position 2 interrupt.
		1 Unmask Digital Communication Block, row 2, position 2 interrupt.
	Endpoint 0	USB Endpoint 0 for the CY8C24x94 and CY7C64215.
1	DBB21	0 Mask Digital Basic Block, row 2, position 1 interrupt.
		1 Unmask Digital Basic Block, row 2, position 1 interrupt.
	Start of Frame	USB Start of Frame (SOF) for the CY8C24x94 and CY7C64215.

(continued on next page)

0,DFh**13.2.80 INT_MSK2 (continued)**

0	DBB20	0	Mask Digital Basic Block, row 2, position 0 interrupt.
		1	Unmask Digital Basic Block, row 2, position 0 interrupt.
	Bus Reset		USB Bus Reset for the CY8C24x94 and CY7C64215.

13.2.81 INT_MSK0

Interrupt Mask Register 0

Individual Register Names and Addresses:

INT_MSK0: 0,E0h

4 COLUMN	7	6	5	4	3	2	1	0
Access : POR	RW : 0	RW : 0	RW : 0	RW : 0	RW : 0	RW : 0	RW : 0	RW : 0
Bit Name	VC3	Sleep	GPIO	Analog 3	Analog 2	Analog 1	Analog 0	V Monitor

2 COLUMN	7	6	5	4	3	2	1	0
Access : POR	RW : 0	RW : 0	RW : 0			RW : 0	RW : 0	RW : 0
Bit Name	VC3	Sleep	GPIO			Analog 1	Analog 0	V Monitor

1 COLUMN	7	6	5	4	3	2	1	0
Access : POR	RW : 0	RW : 0	RW : 0			RW : 0		RW : 0
Bit Name	VC3	Sleep	GPIO			Analog 1		V Monitor

This register is used to enable the individual sources' ability to create pending interrupts.

This register is used to enable the individual sources' ability to create pending interrupts. When an interrupt is masked off, the mask bit is '0'. The interrupt will still post in the interrupt controller. Therefore, clearing the mask bit only prevents a posted interrupt from becoming a pending interrupt. Use the register tables above, in addition to the detailed register bit descriptions below, to determine which bits are reserved for some smaller PSoC devices. Note that reserved bits are grayed table cells and are not described in the bit description section. Reserved bits should always be written with a value of '0'. For additional information, refer to the ["Register Definitions" on page 98](#) in the Interrupt Controller chapter.

Bit	Name	Description
7	VC3	0 Mask VC3 interrupt.
		1 Unmask VC3 interrupt.
6	Sleep	0 Mask sleep interrupt.
		1 Unmask sleep interrupt.
5	GPIO	0 Mask GPIO interrupt.
		1 Unmask GPIO interrupt.
4	Analog 3	0 Mask analog interrupt, column 3.
		1 Unmask analog interrupt.
3	Analog 2	0 Mask analog interrupt, column 2.
		1 Unmask analog interrupt.
2	Analog 1	0 Mask analog interrupt, column 1.
		1 Unmask analog interrupt.
1	Analog 0	0 Mask analog interrupt, column 0.
		1 Unmask analog interrupt.
0	V Monitor	0 Mask voltage monitor interrupt.
		1 Unmask voltage monitor interrupt.

13.2.82 INT_MSK1

Interrupt Mask Register 1

Individual Register Names and Addresses:

INT_MSK1: 0,E1h

4, 2 COLUMN	7	6	5	4	3	2	1	0
Access : POR	RW : 0	RW : 0	RW : 0	RW : 0	RW : 0	RW : 0	RW : 0	RW : 0
Bit Name	DCB13	DCB12	DBB11	DBB10	DCB03	DCB02	DBB01	DBB00

1 COLUMN	7	6	5	4	3	2	1	0
Access : POR					RW : 0	RW : 0	RW : 0	RW : 0
Bit Name					DCB03	DCB02	DBB01	DBB00

This register is used to enable the individual sources' ability to create pending interrupts for digital blocks.

When an interrupt is masked off, the mask bit is '0'. The interrupt will still post in the interrupt controller. Therefore, clearing the mask bit only prevents a posted interrupt from becoming a pending interrupt. Use the register tables above, in addition to the detailed register bit descriptions below, to determine which bits are reserved for some smaller PSoC devices. Note that reserved bits are grayed table cells and are not described in the bit description section. Reserved bits should always be written with a value of '0'. For additional information, refer to the ["Register Definitions"](#) on page 98 in the Interrupt Controller chapter.

Bit	Name	Description
7	DCB13	0 Mask Digital Communication Block, row 1, position 3 interrupt. 1 Unmask Digital Communication Block, row 1, position 3 interrupt.
6	DCB12	0 Mask Digital Communication Block, row 1, position 2 interrupt. 1 Unmask Digital Communication Block, row 1, position 2 interrupt.
5	DBB11	0 Mask Digital Basic Block, row 1, position 1 interrupt. 1 Unmask Digital Basic Block, row 1, position 1 interrupt.
4	DBB10	0 Mask Digital Basic Block, row 1, position 0 interrupt. 1 Unmask Digital Basic Block, row 1, position 0 interrupt.
3	DCB03	0 Mask Digital Communication Block, row 0, position 3 off. 1 Unmask Digital Communication Block, row 0, position 3.
2	DCB02	0 Mask Digital Communication Block, row 0, position 2 off. 1 Unmask Digital Communication Block, row 0, position 2.
1	DBB01	0 Mask Digital Basic Block, row 0, position 1 off. 1 Unmask Digital Basic Block, row 0, position 1.
0	DBB00	0 Mask Digital Basic Block, row 0, position 0 off. 1 Unmask Digital Basic Block, row 0, position 0.

13.2.83 INT_VC

Interrupt Vector Clear Register

Individual Register Names and Addresses:

INT_VC: 0,E2h

	7	6	5	4	3	2	1	0
Access : POR	RC : 00							
Bit Name	Pending Interrupt[7:0]							

This register returns the next pending interrupt and clears all pending interrupts when written.

For additional information, refer to the [“Register Definitions”](#) on page 98 in the Interrupt Controller chapter.

Bit	Name	Description	
7:0	Pending Interrupt[7:0]	Read	Returns vector for highest priority pending interrupt.
		Write	Clears all pending and posted interrupts.

13.2.84 RES_WDT

Reset Watchdog Timer Register

Individual Register Names and Addresses:

RES_WDT: 0,E3h

	7	6	5	4	3	2	1	0
Access : POR	W : 00							
Bit Name	WDSL_Clear[7:0]							

This register is used to clear the watchdog timer and clear both the watchdog timer and the sleep timer.

For additional information, refer to the [“Register Definitions”](#) on page 131 in the Sleep and Watchdog chapter.

Bit	Name	Description
7:0	WDSL_Clear[7:0]	Any write clears the watchdog timer. A write of 38h clears both the watchdog and sleep timers.

13.2.85 DEC_DH

Decimator Data High Register

Individual Register Names and Addresses:

DEC_DH: 0,E4h

	7	6	5	4	3	2	1	0
Access : POR	RC : XX							
Bit Name	Data High Byte[7:0]							

This register is a dual purpose register and is used to read the high byte of the decimator's output or clear the decimator.

When a hardware reset occurs, the internal state of the decimator is reset, but the output data registers (DEC_DH and DEC_DL) are not. For additional information, refer to the "Register Definitions" on page 479 in the Decimator chapter.

Bit	Name	Description	
7:0	Data High Byte[7:0]	Read	Returns the high byte of the decimator.
		Write	Clears the 16-bit accumulator values. Either the DEC_DH or DEC_DL register may be written to clear the accumulators (that is, it is not necessary to write both).

13.2.86 DEC_DL

Decimator Data Low Register

Individual Register Names and Addresses:

DEC_DL: 0,E5h

	7	6	5	4	3	2	1	0
Access : POR	RC : XX							
Bit Name	Data Low Byte[7:0]							

This register is a dual purpose register and is used to read the low byte of the decimator's output or clear the decimator.

When a hardware reset occurs, the internal state of the decimator is reset, but the output data registers (DEC_DH and DEC_DL) are not. For additional information, refer to the "Register Definitions" on page 479 in the Decimator chapter.

Bit	Name	Description	
7:0	Data Low Byte[7:0]	Read	Returns the low byte of the decimator.
		Write	Clears the 16-bit accumulator values. Either the DEC_DH or DEC_DL register may be written to clear the accumulators (that is, it is not necessary to write both).

13.2.87 DEC_CR0

Decimator Control Register 0

Individual Register Names and Addresses:

DEC_CR0: 0,E6h

4 COLUMN	7	6	5	4	3	2	1	0
Access : POR	RW : 0			RW : 0		RW : 0		RW : 0
Bit Name	IGEN[3:0]			ICLKS0		DCOL[1:0]		DCLKS0

2 COLUMN	7	6	5	4	3	2	1	0
Access : POR			RW : 0		RW : 0		RW : 0	
Bit Name			IGEN[1:0]		ICLKS0		DCOL[1:0]	

2L* Column	7	6	5	4	3	2	1	0
Access : POR			RW : 0		RW : 0			
Bit Name			IGEN[1:0]		ICLKS0			

* This table shows the two column limited functionality of the CY8C21x34, CY8C21x23, CY7C603xx, and CYWUSB6953 PSoC devices for this register.

This register contains control bits to access hardware support for ADC operation.

This register is for 4 and 2 column PSoC devices only. In the table above, note that reserved bits are grayed table cells and are not described in the bit description section. Reserved bits should always be written with a value of '0'. For additional information, refer to the "Register Definitions" on page 479 in the Decimator chapter.

Bits	Name	Description
7:4	IGEN[3:0]	Incremental/SSADC Gate Enable. Selects on a column basis which comparator outputs will be gated with the SSADC selected PWM source. 1h Analog Column 0 2h Analog Column 1 4h Analog Column 2. Reserved for the CY8C21x23, CY8C21x34, and CY8C24xxx. 8h Analog Column 3. Reserved for the CY8C21x23, CY8C21x34, and CY8C24xxx.
3	ICLKS0	Incremental/SSADC Gate Source. Along with bits ICLKS3, ICLKS2, and ICLKS1 in the DEC_CR1 register, this bit selects any one of the digital blocks in your device. The bit value for a digital block number that does not exist in a specific PSoC should be considered reserved. For example, a PSoC device with 2 rows may choose any block numbered 0x or 1x, but not a block numbered 2x or 3x. Note The CY8C21xxx PSoC devices also contain a dedicated ADC PWM. When this PWM source is configured, it overrides the ICLKS0 through ICLKS3 digital block source.

(continued on next page)

13.2.87 DEC_CR0 (continued)

3	(cont.)	<p>ICLKS3, ICLKS2, ICLKS1 (see the DEC_CR1 register), ICLKS0</p> <p>0000b Digital block 02 0001b Digital block 12 0010b Digital block 01 0011b Digital block 11 0100b Digital block 00 0101b Digital block 10 0110b Digital block 03 0111b Digital block 13 1000b Digital block 22 1001b Digital block 32 1010b Digital block 21 1011b Digital block 31 1100b Digital block 20 1101b Digital block 30 1110b Digital block 23 1111b Digital block 33</p>
2:1	DCOL[1:0]	<p>Decimator Column Source. Selects the analog comparator column as a data source for the decimator.</p> <p>00b Analog Column 0 01b Analog Column 1 10b Analog Column 2 11b Analog Column 3</p>
0	DCLKS0	<p>Decimator Latch Select. Along with bits DCLKS3, DCLKS2, and DCLKS1 in the DEC_CR1 register, this bit selects any one of the digital blocks in your device. The bit value for a digital block number that does not exist in a specific PSoC should be considered reserved. For example, a PSoC device with 2 rows may choose any block numbered 0x or 1x, but not a block numbered 2x or 3x.</p> <p>DCLKS3, DCLKS2, DCLKS1 (see the DEC_CR1 register), DCLKS0</p> <p>0000b Digital block 02 0001b Digital block 12 0010b Digital block 01 0011b Digital block 11 0100b Digital block 00 0101b Digital block 10 0110b Digital block 03 0111b Digital block 13 1000b Digital block 22 1001b Digital block 32 1010b Digital block 21 1011b Digital block 31 1100b Digital block 20 1101b Digital block 30 1110b Digital block 23 1111b Digital block 33</p>

13.2.88 DEC_CR1

Decimator Control Register 1

Individual Register Names and Addresses:

DEC_CR1: 0,E7h

4 COLUMN	7	6	5	4	3	2	1	0
Access : POR		RW : 0	RW : 0	RW : 0	RW : 0	RW : 0	RW : 0	RW : 0
Bit Name		IDEC	ICLKS3	ICLKS2	ICLKS1	DCLKS3	DCLKS2	DCLKS1

2 COLUMN	7	6	5	4	3	2	1	0
Access : POR	RW : 0	RW : 0	RW : 0	RW : 0	RW : 0	RW : 0	RW : 0	RW : 0
Bit Name	ECNT	IDEC	ICLKS3	ICLKS2	ICLKS1	DCLKS3	DCLKS2	DCLKS1

2L* Column	7	6	5	4	3	2	1	0
Access : POR				RW : 0	RW : 0			
Bit Name				ICLKS2	ICLKS1			

* This table shows the two column limited functionality of the CY8C21x34, CY8C21x23, CY7C603xx, and CYWUSB6953 PSoC devices for this register.

This register is used to configure signals for ADC operation.

This register is for 4 and 2 column PSoC devices only. Note that the DEC_CR1 register's bit 7 (ECNT) is only available in PSoC devices with a type 1 decimator and is reserved in PSoC devices with a type 2 decimator. Refer to the table titled "[Decimator Availability for PSoC Devices](#)" on page 475 to determine which type of decimator your PSoC device uses. Note that reserved bits are grayed table cells and are not described in the bit description section. Reserved bits should always be written with a value of '0'. For additional information, refer to the "[Register Definitions](#)" on page 479 in the Decimator chapter.

Bits	Name	Description
7	ECNT	0 Disable Decimator as a counter for incremental ADC. Configure for delta sigma operation. 1 Enable Decimator as a counter for incremental ADC operation.
6	IDEC	Invert the Digital Block Latch Control (selected by DCLKS3, DCLKS2, DCLKS1, and DCLKS0). 0 Non-inverted 1 Inverted
5:3	ICLKSx	Incremental/SSADC Gate Source. Along with ICLKS0 in DEC_CR0, selects any one of the digital blocks in your device. The bit value for a digital block number that does not exist in a specific PSoC should be considered reserved. For example, a PSoC device with 2 rows may choose any block numbered 0x or 1x, but not a block numbered 2x or 3x. Note The CY8C21xxx PSoC devices also contain a dedicated ADC PWM. When this PWM source is configured, it overrides the ICLKS0 through ICLKS3 digital block source.

(continued on next page)

13.2.88 DEC_CR1 (continued)

5:3 ICLKSx **ICLKS3, ICLKS2, ICLKS1, ICLKS0 (see the DEC_CR0 register)**
(cont.)

0000b Digital block 02 *
 0001b Digital block 12 *
 0010b Digital block 01 *
 0011b Digital block 11 *
 0100b Digital block 00
 0101b Digital block 10
 0110b Digital block 03
 0111b Digital block 13
 1000b Digital block 22
 1001b Digital block 32
 1010b Digital block 21
 1011b Digital block 31
 1100b Digital block 20
 1101b Digital block 30
 1110b Digital block 23
 1111b Digital block 33

* For Silicon Rev A of the CY8C27x43 PSoC device, only digital blocks 01, 02, 11, and 12 are valid.

2:0 DCLKSx

Decimator Latch Select. Along with DCLKS0 in DEC_CR0, selects any one of the digital blocks in your device. The bit value for a digital block number that does not exist in a specific PSoC should be considered reserved. For example, a PSoC device with 2 rows may choose any block numbered 0x or 1x, but not a block numbered 2x or 3x.

DCLKS3, DCLKS2, DCLKS1, DCLKS0 (see the DEC_CR0 register)

0000b Digital block 02
 0001b Digital block 12
 0010b Digital block 01
 0011b Digital block 11
 0100b Digital block 00
 0101b Digital block 10
 0110b Digital block 03
 0111b Digital block 13
 1000b Digital block 22
 1001b Digital block 32
 1010b Digital block 21
 1011b Digital block 31
 1100b Digital block 20
 1101b Digital block 30
 1110b Digital block 23
 1111b Digital block 33

13.2.89 CPU_F

M8C Flag Register

Individual Register Names and Addresses:

CPU_F: x,F7h

	7	6	5	4	3	2	1	0
Access : POR	RL : 0			RL : 0		RL : 0	RL : 0	RL : 0
Bit Name	PgMode[1:0]			XIO		Carry	Zero	GIE

This register provides read access to the M8C flags.

The AND f, expr; OR f, expr; and XOR f, expr flag instructions can be used to modify this register. In the table above, note that reserved bits are grayed table cells and are not described in the bit description section below. Reserved bits should always be written with a value of '0'. For additional information, refer to the [“Register Definitions” on page 72](#) in the M8C chapter and the [“Register Definitions” on page 98](#) in the Interrupt Controller chapter.

Bit	Name	Description
7:6	PgMode[1:0]	<p>00b Direct Address mode and Indexed Address mode operands are referred to RAM Page 0, regardless of the values of CUR_PP and IDX_PP. Note that this condition prevails on entry to an Interrupt Service Routine when the CPU_F register is cleared.</p> <p>01b Direct Address mode instructions are referred to page 0. Indexed Address mode instructions are referred to the RAM page specified by the stack page pointer, STK_PP.</p> <p>10b Direct Address mode instructions are referred to the RAM page specified by the current page pointer, CUR_PP. Indexed Address mode instructions are referred to the RAM page specified by the index page pointer, IDX_PP.</p> <p>11b Direct Address mode instructions are referred to the RAM page specified by the current page pointer, CUR_PP. Indexed Address mode instructions are referred to the RAM page specified by the stack page pointer, STK_PP.</p>
4	XIO	<p>0 Normal register address space</p> <p>1 Extended register address space. Primarily used for configuration.</p>
2	Carry	<p>Set by the M8C CPU Core to indicate whether there has been a carry in the previous logical/arithmetic operation.</p> <p>0 No carry</p> <p>1 Carry</p>
1	Zero	<p>Set by the M8C CPU Core to indicate whether there has been a zero result in the previous logical/arithmetic operation.</p> <p>0 Not equal to zero</p> <p>1 Equal to zero</p>
0	GIE	<p>0 M8C will not process any interrupts.</p> <p>1 Interrupt processing enabled.</p>

0,FDh

13.2.90 DAC_D

Analog Mux DAC Data Register

Individual Register Names and Addresses:

MXDACD : 0,FDh

	7	6	5	4	3	2	1	0
Access : POR	RW : 00							
Bit Name	DACDATA[7:0]							

This register specifies the 8-bit multiplying factor that determines the output DAC current.

This register is only used by the CY8C24x94, CY8C21x34, CY7C64215, CY7C603xx, and CYWUSB6953 PSoC devices. For additional information, refer to the ["Register Definitions"](#) on page 521 in the IO Analog Multiplexer chapter.

Bits	Name	Description
7:0	DACDATA[7:0]	<p>This 8-bit value selects the number of current units that combine to form the DAC current. This current then drives the analog mux bus when DAC mode is enabled in the MXDACCR register. For example, a setting of 80h means that the charging current will be 128 current units.</p> <p>The current unit size depends on the range setting in the MXDACCR register.</p>

13.2.91 CPU_SCR1

System Status and Control Register 1

Individual Register Names and Addresses:

CPU_SCR1: x,FEh

	7	6	5	4	3	2	1	0
Access : POR	R : 0			RW : 0	R : 0	RW : 0		RW : 0
Bit Name	IRESS			SLIMO	ECO EXW	ECO EX		IRAMDIS

This register is used to convey the status and control of events related to internal resets and watchdog reset.

In the table above, note that reserved bits are grayed table cells and are not described in the bit description section. Reserved bits should always be written with a value of '0'. For additional information, refer to the “[Register Definitions](#)” on page 78 in the SROM chapter or “[Register Definitions](#)” on page 121 of the External Crystal Oscillator (ECO) chapter.

Notes

1. Refer to the “[PSoC Device Distinctions](#)” on page 113, in the Internal Main Oscillator chapter, for more information on bit 4, SLIMO.
2. Bits 3 and 2 (ECO EXW and ECO EX, respectively) cannot be used by the CY8C27x43 for silicon revision A, and by the CY8C24x23 and CY8C22x13 PSoC devices.

Bit	Name	Description
7	IRESS	This bit is read only. 0 Boot phase only executed once. 1 Boot phase occurred multiple times.
4	SLIMO	Reduces frequency of the internal main oscillator (IMO). This bit is reserved on PSoC devices that do not support the slow IMO (see the “ Architectural Description ” on page 113). 0 IMO produces 24 MHz 1 Slow IMO (6 MHz)
3	ECO EXW	ECO Exists Written. 1 The ECO Exists Written bit has been written with a '1' or '0' and is now locked. 0 The ECO Exists Written bit has never been written in User mode.
2	ECO EX	ECO Exists (write once – see the explanation in “ Register Definitions ” on page 131). 1 ECO operation exists (set/reset OSC_CR[7] to enable/disable). 0 ECO operation does not exist. 32 kHz clock source is locked to operate from the ILO.
0	IRAMDIS	0 SRAM is initialized to 00h after POR, XRES, and WDR. 1 Address 03h - D7h of SRAM Page 0 are not modified by WDR.

13.2.92 CPU_SCR0

System Status and Control Register 0

Individual Register Names and Addresses:

CPU_SCR0: x,FFh

	7	6	5	4	3	2	1	0
Access : POR	R : 0		RC : 0	RC : 1	RW : 0			RW : 0
Bit Name	GIES		WDRS	PORS	Sleep			STOP

This register is used to convey the status and control of events for various functions of a PSoC device.

In the table above, note that reserved bits are grayed table cells and are not described in the bit description section. Reserved bits should always be written with a value of '0'. For additional information, refer to the "Register Definitions" on page 131 in the Sleep and Watchdog chapter.

Bit	Name	Description
7	GIES	Global interrupt enable status. It is recommended that the user read the Global Interrupt Enable Flag bit from the CPU_F register on page 249 . This bit is Read Only for GIES. Its use is discouraged, as the Flag register is now readable at address x,F7h (read only).
5	WDRS	Watchdog Reset Status. This bit may not be set by user code; however, it may be cleared by writing it with a '0'. 0 No Watchdog Reset has occurred. 1 Watchdog Reset has occurred.
4	PORS	Power On Reset Status. This bit may not be set by user code; however, it may be cleared by writing it with a '0'. 0 Power On Reset has not occurred and watchdog timer is enabled. 1 Will be set after external reset or Power On Reset.
3	Sleep	Set by the user to enable the CPU sleep state. CPU will remain in Sleep mode until any interrupt is pending. 0 Normal operation 1 Sleep
0	STOP	0 M8C is free to execute code. 1 M8C is halted. Can only be cleared by POR, XRES, or WDR.

13.3 Bank 1 Registers

The following registers are all in bank 1 and are listed in address order. Registers that are in both Bank 0 and Bank 1 are listed in address order in the section titled “Bank 0 Registers” on page 149.

13.3.1 PRTxDM0

Port Drive Mode Bit Register 0

Individual Register Names and Addresses:

PRT0DM0 : 1,00h PRT1DM0 : 1,04h PRT2DM0 : 1,08h PRT3DM0 : 1,0Ch
 PRT4DM0 : 1,10h PRT5DM0 : 1,14h PRT6DM0 : 1,18h PRT7DM0 : 1,1Ch

	7	6	5	4	3	2	1	0
Access : POR	RW : 00							
Bit Name	Drive Mode 0[7:0]							

This register is one of three registers whose combined value determines the unique Drive mode of each bit in a GPIO port.

In register PRTxDM0 there are eight possible drive modes for each port pin. Three mode bits are required to select one of these modes, and these three bits are spread into three different registers (PRTxDM0, “PRTxDM1” on page 254, and “PRTxDM2” on page 152). The bit position of the effected port pin (for example, Pin[2] in Port 0) is the same as the bit position of each of the three Drive Mode register bits that control the Drive mode for that pin (for example, Bit[2] in PRT0DM0, bit[2] in PRT0DM1, and bit[2] in PRT0DM2). The three bits from the three registers are treated as a group. These are referred to as DM2, DM1, and DM0, or together as DM[2:0].

All Drive mode bits are shown in the sub-table below ([210] refers to the combination (in order) of bits in a given bit position); however, this register only controls the **least significant bit (LSb)** of the Drive mode.

Note that the CY8C27643 has a 4-bit wide Port 5 and the CY8C21x34, CY7C603xx, and CYWUSB6953 have a 4-bit wide Port 3. The upper nibble of this register will return the last data bus value when read and should be masked off prior to using this information. For additional information, refer to the “Register Definitions” on page 107 in the GPIO chapter.

The CY8CNP1xx has a 2 bit wide port 3. Make certain to mask nonavailable I/O bits while accessing the data register for this port

Bit	Name	Description																																				
7:0	Drive Mode 0[7:0]	Bit 0 of the Drive mode, for each of 8-port pins, for a GPIO port.																																				
		<table border="1"> <thead> <tr> <th>[210]</th> <th>Pin Output High</th> <th>Pin Output Low</th> <th>Notes</th> </tr> </thead> <tbody> <tr> <td>000b</td> <td>Strong</td> <td>Resistive</td> <td></td> </tr> <tr> <td>001b</td> <td>Strong</td> <td>Strong</td> <td></td> </tr> <tr> <td>010b</td> <td>High Z</td> <td>High Z</td> <td>Digital input enabled.</td> </tr> <tr> <td>011b</td> <td>Resistive</td> <td>Strong</td> <td></td> </tr> <tr> <td>100b</td> <td>Slow + strong</td> <td>High Z</td> <td></td> </tr> <tr> <td>101b</td> <td>Slow + strong</td> <td>Slow + strong</td> <td></td> </tr> <tr> <td>110b</td> <td>High Z</td> <td>High Z</td> <td>Reset state. Digital input disabled for zero power.</td> </tr> <tr> <td>111b</td> <td>High Z</td> <td>Slow + strong</td> <td>I2C Compatible mode.</td> </tr> </tbody> </table> <p>Note A bold digit, in the table above, signifies that the digit is used in this register.</p>	[210]	Pin Output High	Pin Output Low	Notes	000b	Strong	Resistive		001b	Strong	Strong		010b	High Z	High Z	Digital input enabled.	011b	Resistive	Strong		100b	Slow + strong	High Z		101b	Slow + strong	Slow + strong		110b	High Z	High Z	Reset state. Digital input disabled for zero power.	111b	High Z	Slow + strong	I2C Compatible mode.
[210]	Pin Output High	Pin Output Low	Notes																																			
000b	Strong	Resistive																																				
001b	Strong	Strong																																				
010b	High Z	High Z	Digital input enabled.																																			
011b	Resistive	Strong																																				
100b	Slow + strong	High Z																																				
101b	Slow + strong	Slow + strong																																				
110b	High Z	High Z	Reset state. Digital input disabled for zero power.																																			
111b	High Z	Slow + strong	I2C Compatible mode.																																			

13.3.2 PRTxDM1

Port Drive Mode Bit Register 1

Individual Register Names and Addresses:

PRT0DM1 : 1,01h PRT1DM1 : 1,05h PRT2DM1 : 1,09h PRT3DM1 : 1,0Dh
 PRT4DM1 : 1,11h PRT5DM1 : 1,15h PRT6DM1 : 1,19h PRT7DM1 : 1,1Dh

	7	6	5	4	3	2	1	0
Access : POR	RW : FF							
Bit Name	Drive Mode 1[7:0]							

This register is one of three registers whose combined value determines the unique Drive mode of each bit in a GPIO port.

In register PRTxDM1 there are eight possible drive modes for each port pin. Three mode bits are required to select one of these modes, and these three bits are spread into three different registers (“PRTxDM0” on page 253, PRTxDM1, and “PRTxDM2” on page 152). The bit position of the effected port pin (for example, Pin[2] in Port 0) is the same as the bit position of each of the three Drive Mode register bits that control the Drive mode for that pin (for example, Bit[2] in PRT0DM0, bit[2] in PRT0DM1, and bit[2] in PRT0DM2). The three bits from the three registers are treated as a group. These are referred to as DM2, DM1, and DM0, or together as DM[2:0].

All Drive mode bits are shown in the sub-table below ([210] refers to the combination (in order) of bits in a given bit position); however, this register only controls the middle bit of the Drive mode.

Note that the CY8C27643 has a 4-bit wide Port 5 and the CY8C21x34, CY7C603xx, and CYWUSB6953 have a 4-bit wide Port 3. The upper nibble of this register will return the last data bus value when read and should be masked off prior to using this information. For additional information, refer to the “Register Definitions” on page 107 in the GPIO chapter.

The CY8CNP1xx has a 2 bit wide port 3. Make certain to mask nonavailable I/O bits while accessing the data register for this port

Bit	Name	Description																																				
7:0	Drive Mode 1[7:0]	Bit 1 of the Drive mode, for each of 8-port pins, for a GPIO port.																																				
		<table border="1"> <thead> <tr> <th>[210]</th> <th>Pin Output High</th> <th>Pin Output Low</th> <th>Notes</th> </tr> </thead> <tbody> <tr> <td>000b</td> <td>Strong</td> <td>Resistive</td> <td></td> </tr> <tr> <td>001b</td> <td>Strong</td> <td>Strong</td> <td></td> </tr> <tr> <td>010b</td> <td>High Z</td> <td>High Z</td> <td>Digital input enabled.</td> </tr> <tr> <td>011b</td> <td>Resistive</td> <td>Strong</td> <td></td> </tr> <tr> <td>100b</td> <td>Slow + strong</td> <td>High Z</td> <td></td> </tr> <tr> <td>101b</td> <td>Slow + strong</td> <td>Slow + strong</td> <td></td> </tr> <tr> <td>110b</td> <td>High Z</td> <td>High Z</td> <td>Reset state. Digital input disabled for zero power.</td> </tr> <tr> <td>111b</td> <td>High Z</td> <td>Slow + strong</td> <td>I2C Compatible mode.</td> </tr> </tbody> </table> <p>Note A bold digit, in the table above, signifies that the digit is used in this register.</p>	[210]	Pin Output High	Pin Output Low	Notes	000b	Strong	Resistive		001b	Strong	Strong		010b	High Z	High Z	Digital input enabled.	011b	Resistive	Strong		100b	Slow + strong	High Z		101b	Slow + strong	Slow + strong		110b	High Z	High Z	Reset state. Digital input disabled for zero power.	111b	High Z	Slow + strong	I2C Compatible mode.
[210]	Pin Output High	Pin Output Low	Notes																																			
000b	Strong	Resistive																																				
001b	Strong	Strong																																				
010b	High Z	High Z	Digital input enabled.																																			
011b	Resistive	Strong																																				
100b	Slow + strong	High Z																																				
101b	Slow + strong	Slow + strong																																				
110b	High Z	High Z	Reset state. Digital input disabled for zero power.																																			
111b	High Z	Slow + strong	I2C Compatible mode.																																			

13.3.3 PRTxIC0

Port Interrupt Control Register 0

Individual Register Names and Addresses:

PRT0IC0 : 1,02h PRT1IC0 : 1,06h PRT2IC0 : 1,0Ah PRT3IC0 : 1,0Eh
 PRT4IC0 : 1,12h PRT5IC0 : 1,16h PRT6IC0 : 1,1Ah PRT7IC0 : 1,1Eh

	7	6	5	4	3	2	1	0
Access : POR	RW : 00							
Bit Name	Interrupt Control 0[7:0]							

This register is one of two registers whose combined value determine the unique Interrupt mode of each bit in a GPIO port.

In register PRTxIC0 there are four possible interrupt modes for each port pin. Two mode bits are required to select one of these modes and these two bits are spread into two different registers (PRTxIC0 and “PRTxIC1” on page 256). The bit position of the effected port pin (for example, Pin[2] in Port 0) is the same as the bit position of each of the interrupt control register bits that control the Interrupt mode for that pin (for example, Bit[2] in PRT0IC0 and bit[2] in PRT0IC1). The two bits from the two registers are treated as a group. In the sub-table below, “[0]” refers to the combination (in order) of bits in a given position, one bit from PRTxIC1 and one bit from PRTxIC0.

Note that the CY8C27643 has a 4-bit wide Port 5 and the CY8C21x34, CY7C603xx, and CYWUSB6953 have a 4-bit wide Port 3. The upper nibble of this register will return the last data bus value when read and should be masked off prior to using this information. For additional information, refer to the “Register Definitions” on page 107 in the GPIO chapter.

The CY8CNP1xx has a 2 bit wide port 3. Make certain to mask nonavailable I/O bits while accessing the data register for this port

Bit	Name	Description										
7:0	Interrupt Control 0[7:0]	<table border="0"> <tr> <td>[10]</td> <td>Interrupt Type</td> </tr> <tr> <td>00b</td> <td>Disabled</td> </tr> <tr> <td>01b</td> <td>Low</td> </tr> <tr> <td>10b</td> <td>High</td> </tr> <tr> <td>11b</td> <td>Change from last read</td> </tr> </table>	[10]	Interrupt Type	00b	Disabled	01b	Low	10b	High	11b	Change from last read
[10]	Interrupt Type											
00b	Disabled											
01b	Low											
10b	High											
11b	Change from last read											

Note A bold digit, in the table above, signifies that the digit is used in this register.

13.3.4 PRTxIC1

Port Interrupt Control Register 1

Individual Register Names and Addresses:

PRT0IC1 : 1,03h PRT1IC1 : 1,07h PRT2IC1 : 1,0Bh PRT3IC1 : 1,0Fh
 PRT4IC1 : 1,13h PRT5IC1 : 1,17h PRT6IC1 : 1,1Bh PRT7IC1 : 1,1Fh

	7	6	5	4	3	2	1	0
Access : POR	RW : 00							
Bit Name	Interrupt Control 1[7:0]							

This register is one of two registers whose combined value determine the unique Interrupt mode of each bit in a GPIO port.

In register PRTxIC1 there are four possible interrupt modes for each port pin. Two mode bits are required to select one of these modes and these two bits are spread into two different registers (“PRTxIC0” on page 255 and PRTxIC1). The bit position of the effected port pin (for example, Pin[2] in Port 0) is the same as the bit position of each of the interrupt control register bits that control the Interrupt mode for that pin (for example, Bit[2] in PRT0IC0 and bit[2] in PRT0IC1). The two bits from the two registers are treated as a group. In the sub-table below, “[1]” refers to the combination (in order) of bits in a given position, one bit from PRTxIC1 and one bit from PRTxIC0.

Note that the CY8C27643 has a 4-bit wide Port 5 and the CY8C21x34, CY7C603xx, and CYWUSB6953 have a 4-bit wide Port 3. The upper nibble of this register will return the last data bus value when read and should be masked off before using this information. For additional information, refer to the “Register Definitions” on page 107 in the GPIO chapter.

The CY8CNP1xx has a 2 bit wide port 3. Make certain to mask nonavailable I/O bits while accessing the data register for this port

Bit	Name	Description
7:0	Interrupt Control 1[7:0]	<p>[10] Interrupt Type</p> <p>00b Disabled</p> <p>01b Low</p> <p>10b High</p> <p>11b Change from last read</p>

Note A bold digit, in the table above, signifies that the digit is used in this register.

13.3.5 DxBxxFN

Digital Basic/Communications Type B Block Function Register

Individual Register Names and Addresses:

DBB00FN : 1,20h	DBB01FN : 1,24h	DCB02FN : 1,28h	DCB03FN : 1,2Ch
DBB10FN : 1,30h	DBB11FN : 1,34h	DCB12FN : 1,38h	DCB13FN : 1,3Ch
DBB20FN : 1,40h	DBB21FN : 1,44h	DCB22FN : 1,48h	DCB23FN : 1,4Ch
DBB30FN : 1,50h	DBB31FN : 1,54h	DCB32FN : 1,58h	DCB33FN : 1,5Ch

	7	6	5	4	3	2	1	0
Access : POR	RW : 0	RW : 0	RW : 0	RW : 0		RW : 0		
Bit Name	Data Invert	BCEN	End Single	Mode[1:0]		Function[2:0]		

This register contains the primary Mode and Function bits that determine the function of the block.

Before changing any of the configuration registers (DxBxxFN, DxBxxIN, and DxBxxOU), disable the corresponding digital block by setting bit 0 in the CR0 or DxBxxCR0 register to '0'. The values in the DxBxxFN register should not be changed while the block is enabled. After all configuration changes are made, enable the block by setting bit 0 in the DxBxxCR0 register to '1'.

The naming convention for this register is as follows. The first 'x' in the digital register's name represents either "B" for basic or "C" for communication. For rows of digital PSoC blocks and their registers, the second 'x' set represents <Prefix>mn<Suffix>, where m=row index, n=column index. Therefore, DCB12FN is a digital communication register for a digital PSoC block in row 1 column 2. Depending on the digital row characteristics of your PSoC device, some addresses may not be available. For additional information, refer to the "Register Definitions" on page 345 in the Digital Blocks chapter.

Bit	Name	Description
7	Data Invert	0 Data input is non-inverted. 1 Data input is inverted.
6	BCEN	Enable Primary Function Output to drive the broadcast net. 0 Disable 1 Enable
5	End Single	0 Block is not the end of a chained function or the function is not chainable. 1 Block is the end of a chained function or a standalone block in a chainable function.
4:3	Mode[1:0]	These bits are function dependent and are described by function as follows.
	Timer or Counter:	Mode[0] signifies the interrupt type. 0 Interrupt on Terminal Count 1 Interrupt on Compare True Mode[1] signifies the compare type. 0 Compare on Less Than or Equal 1 Compare on Less Than
	CRCPRS:	Mode[1:0] are encoded as the Compare Type. 00b Compare on Equal 01b Compare on Less Than or Equal 10b Reserved 11b Compare on Less Than

(continued on next page)

13.3.5 DxBxxFN (continued)

4:3 (cont.)	Dead Band:	Mode[1:0] are encoded as the Kill Type. 00b Synchronous Restart KILL mode 01b Disable KILL mode 10b Asynchronous KILL mode 11b Reserved
	UART:	Mode[0] signifies the Direction. 0 Receiver 1 Transmitter Mode[1] signifies the Interrupt Type. 0 Interrupt on TX Reg Empty 1 Interrupt on TX Complete
	SPI:	Mode[0] signifies the Type. 0 Master 1 Slave Mode[1] signifies the Interrupt Type. 0 Interrupt on TX Reg Empty 1 Interrupt on SPI Complete
2:0	Function[2:0]	000b Timer (chainable) 001b Counter (chainable) 010b CRCPRS (chainable) 011b Reserved 100b Dead Band 101b UART (DCBxx blocks only) 110b SPI (DCBxx blocks only) 111b Reserved

13.3.6 DxBxxIN

Digital Basic/Communications Type B Block Input Register

Individual Register Names and Addresses:

DBB00IN : 1,21h	DBB01IN : 1,25h	DCB02IN : 1,29h	DCB03IN : 1,2Dh
DBB10IN : 1,31h	DBB11IN : 1,35h	DCB12IN : 1,39h	DCB13IN : 1,3Dh
DBB20IN : 1,41h	DBB21IN : 1,45h	DCB22IN : 1,49h	DCB23IN : 1,4Dh
DBB30IN : 1,51h	DBB31IN : 1,55h	DCB32IN : 1,59h	DCB33IN : 1,5Dh

	7	6	5	4	3	2	1	0
Access : POR	RW : 0				RW : 0			
Bit Name	Data Input[3:0]				Clock Input[3:0]			

These registers are used to select the data and clock inputs.

Before changing any of the configuration registers (DxBxxFN, DxBxxIN, and DxBxxOU), disable the corresponding digital block by setting bit 0 in the CR0 or DxBxxCR0 register to '0'. The values in this register should not be changed while the block is enabled. After all configuration changes are made, enable the block by setting bit 0 in the CR0 register to '1'.

The naming convention for this register is as follows. The first 'x' in the digital register's name represents either "B" for basic or "C" for communication. For rows of digital PSoC blocks and their registers, the second 'x' set represents <Prefix>mn<Suffix>, where m=row index, n=column index. Therefore, DCB12IN is a digital communication register for a digital PSoC block in row 1 column 2. Depending on the digital row characteristics of your PSoC device, some addresses may not be available. For additional information, refer to the "Register Definitions" on page 345 in the Digital Blocks chapter.

Bit	Name	Description
7:4	Data Input[3:0]	0h Low (0) 1h High (1) 2h Row broadcast net 3h Chain function to previous block (low (0) in block DBB00IN) 4h Analog column comparator 0 5h Analog column comparator 1 6h Analog column comparator 2 7h Analog column comparator 3 8h Row output 0 9h Row output 1 Ah Row output 2 Bh Row output 3 Ch Row input 0 Dh Row input 1 Eh Row input 2 Fh Row input 3

(continued on next page)

13.3.6 DxBxxIN (continued)

3:0	Clock Input[3:0]	0h	Clock disabled (low)
		1h	VC3
		2h	Row broadcast net
		3h	Previous block primary output (low for DBB00)
		4h	SYSCLKX2
		5h	VC1
		6h	VC2
		7h	CLK32K
		8h	Row output 0
		9h	Row output 1
		Ah	Row output 2
		Bh	Row output 3
		Ch	Row input 0
		Dh	Row input 1
		Eh	Row input 2
		Fh	Row input 3

13.3.7 DxBxxOU

Digital Basic/Communications Type B Block Output Register

Individual Register Names and Addresses:

DBB00OU : 1,22h	DBB01OU : 1,26h	DCB02OU : 1,2Ah	DCB03OU : 1,2Eh
DBB10OU : 1,32h	DBB11OU : 1,36h	DCB12OU : 1,3Ah	DCB13OU : 1,3Eh
DBB20OU : 1,42h	DBB21OU : 1,46h	DCB22OU : 1,4Ah	DCB23OU : 1,4Eh
DBB30OU : 1,52h	DBB31OU : 1,56h	DCB32OU : 1,5Ah	DCB33OU : 1,5Eh

	7	6	5	4	3	2	1	0
Access : POR	RW : 0		RW : 0	RW : 0		RW : 0	RW : 0	
Bit Name	AUXCLK		AUXEN	AUX IO Select[1:0]		OUTEN	Output Select[1:0]	

This register is used to control the connection of digital block outputs to the available row interconnect and control clock resynchronization.

Before changing any of the configuration registers (DxBxxFN, DxBxxIN, and DxBxxOU), disable the corresponding digital block by setting bit 0 in the CR0 or DxBxxCR0 register to '0'. The values in this register should not be changed while the block is enabled. After all configuration changes are made, enable the block by setting bit 0 in the DxBxxCR0 register to '1'.

The naming convention for this register is as follows. The first 'x' in the digital register's name represents either "B" for basic or "C" for communication. For rows of digital PSoC blocks and their registers, the second 'x' set represents <Prefix>mn<Suffix>, where m=row index, n=column index. Therefore, DBB12OU is a digital basic register for a digital PSoC block in row 1 column 2. Depending on the digital row characteristics of your PSoC device, some addresses may not be available. For additional information, refer to the "Register Definitions" on page 345 in the Digital Blocks chapter.

Bit	Name	Description
7:6	AUXCLK	00b No sync 16-to-1 clock mux output
		01b Synchronize Output of 16-to-1 clock mux to SYSCLK
		10b Synchronize Output of 16-to-1 clock mux to SYSCLKX2
		11b SYSCLK Directly connect SYSCLK to block clock input
5	AUXEN	Auxiliary IO Enable (function dependent)
		All Functions except SPI Slave: Enable Auxiliary Output Driver
		0 Disabled 1 Enabled
		SPI Slave: Input Source for SS_
		0 Row Input [3:0], as selected by the AUX IO Select bits
		1 Force SS_ Active
4:3	AUX IO Select[1:0]	Auxiliary IO Select Function Output (function dependent)
		All Functions except SPI Slave: Row Output Select
		00b Row Output 0
		01b Row Output 1
		10b Row Output 2
		11b Row Output 3
		SPI Slave Source for SS_ Input if AUXEN =0.
		00b Row Input 0
		01b Row Input 1
		10b Row Input 2
11b Row Input 3		

(continued on next page)

13.3.7 DxBxxOU (continued)

4:3 (cont.)	AUX IO Select[1:0]	SPI Slave Source for SS_ Input if AUXEN =1. 00b Force SS_ Active 01b Reserved 10b Reserved 11b Reserved
2	OUTEN	Enable Primary Function Output Driver 0 Disabled 1 Enabled
1:0	Output Select[1:0]	Row Output Select for Primary Function Output 00b Row Output 0 01b Row Output 1 10b Row Output 2 11b Row Output 3

13.3.8 PMAx_WA

PMA Write Address Register

Individual Register Names and Addresses:

PMA0_WA : 1,40h	PMA1_WA : 1,41h	PMA2_WA : 1,42h	PMA3_WA : 1,43h
PMA4_WA : 1,44h	PMA5_WA : 1,45h	PMA6_WA : 1,46h	PMA7_WA : 1,47h

	7	6	5	4	3	2	1	0
Access : POR	RW : 00							
Bit Name	Address[7:0]							

This register is used to set the beginning SRAM address for the PMA channel.

This register is only used by the CY8C24x94 and CY7C64215 PSoC devices. For additional information, refer to the “[Register Definitions](#)” on page 529 in the Full-Speed USB chapter.

Bit	Name	Description
7:0	Address[7:0]	Sets the starting address for writes to the corresponding PMA channel.

13.3.9 PMAx_RA

PMA Read Address Register

Individual Register Names and Addresses:

PMA0_RA : 1,50h PMA1_RA : 1,51h PMA2_RA : 1,52h PMA3_RA : 1,53h
 PMA4_RA : 1,54h PMA5_RA : 1,55h PMA6_RA : 1,56h PMA7_RA : 1,57h

	7	6	5	4	3	2	1	0
Access : POR	RW : 00							
Bit Name	Address[7:0]							

This register is used to set the beginning address for the PMA channel.

This register is only used by the CY8C24x94 and CY7C64215 PSoC devices. For additional information, refer to the “[Register Definitions](#)” on [page 529](#) in the Full-Speed USB chapter.

Bit	Name	Description
7:0	Address[7:0]	Sets the starting address for reads to the corresponding PMA channel and prefetches the first data byte.

13.3.10 CLK_CR0

Analog Column Clock Control Register 0

Individual Register Names and Addresses:

CLK_CR0: 1,60h

4 COLUMN	7	6	5	4	3	2	1	0
Access : POR	RW : 0		RW : 0		RW : 0		RW : 0	
Bit Name	AColumn3[1:0]		AColumn2[1:0]		AColumn1[1:0]		AColumn0[1:0]	

2, 2L* COLUMN	7	6	5	4	3	2	1	0
Access : POR					RW : 0		RW : 0	
Bit Name					AColumn1[1:0]		AColumn0[1:0]	

* This table also shows the two column limited functionality of the CY8C21x34, CY8C21x23, CY7C603xx, and CYWUSB6953 PSoC devices for this register.

1 COLUMN	7	6	5	4	3	2	1	0
Access : POR					RW : 0			
Bit Name					AColumn1[1:0]			

This register is used to select the clock source for an individual analog column.

Each column has two bits that select the column clock input source. The resulting column clock frequency is the selected input clock frequency divided by four, except in the two column analog system for the CY8C21x34, CY8C21x23, CY7C603xx, and CYWUSB6953 PSoC devices where clock dividing is controlled by the [CLK_CR3](#) register. Use the register tables above, in addition to the detailed register bit descriptions below, to determine which bits are reserved for some smaller PSoC devices. Note that reserved bits are grayed table cells and are not described in the bit description section. Reserved bits should always be written with a value of '0'. For additional information, refer to the "Register Definitions" on page 386 in the Analog Interface chapter.

Bits	Name	Description
7:6	AColumn3[1:0]	Clock selection for column 3. 00b Variable Clock 1 (VC1) 01b Variable Clock 2 (VC2) 10b Analog Clock 0 (ACLK0) 11b Analog Clock 1 (ACLK1)
5:4	AColumn2[1:0]	Clock selection for column 2. 00b Variable Clock 1 (VC1) 01b Variable Clock 2 (VC2) 10b Analog Clock 0 (ACLK0) 11b Analog Clock 1 (ACLK1)
3:2	AColumn1[1:0]	Clock selection for column 1. 00b Variable Clock 1 (VC1) 01b Variable Clock 2 (VC2) 10b Analog Clock 0 (ACLK0) 11b Analog Clock 1 (ACLK1)
1:0	AColumn0[1:0]	Clock selection for column 0. 00b Variable Clock 1 (VC1) 01b Variable Clock 2 (VC2) 10b Analog Clock 0 (ACLK0) 11b Analog Clock 1 (ACLK1)

13.3.11 CLK_CR1

Analog Clock Source Control Register 1

Individual Register Names and Addresses:

CLK_CR1: 1,61h

4, 2 COLUMN	7	6	5	4	3	2	1	0
Access : POR		RW : 0		RW : 0			RW : 0	
Bit Name		SHDIS		ACLK1[2:0]			ACLK0[2:0]	

2L* Column	7	6	5	4	3	2	1	0
Access : POR					RW : 0			RW : 0
Bit Name					ACLK1[1:0]			ACLK0[1:0]

* This table shows the two column limited functionality of the CY8C21x34, CY8C21x23, CY7C603xx, and CYWUSB6953 PSoC devices for this register.

This register is used to select the clock source for an individual analog column.

This register is for 4 and 2 column PSoC devices only. There are two ranges of Digital PSoC blocks shown. The range is set by bits ACLK0R and ACLK1R in register [CLK_CR2](#). In the table above, note that reserved bits are grayed table cells and are not described in the bit description section below. Reserved bits should always be written with a value of '0'. For additional information, refer to the "Register Definitions" on [page 386](#) in the Analog Interface chapter.

Bits	Name	Description
6	SHDIS	Sample and hold disable. 0 Enabled 1 Disabled
5:3	ACLK1[2:0]	Select the Digital Block whose primary output is the clocking source for Analog Clock 1. 000b Digital Basic Block 00 001b Digital Basic Block 01 010b Digital Communication Block 02 011b Digital Communication Block 03 100b Digital Basic Block 10, Reserved for CY8C21x23 101b Digital Basic Block 11, Reserved for CY8C21x23 110b Digital Communication Block 12, Reserved for CY8C21x23 111b Digital Communication Block 13, Reserved for CY8C21x23
2:0	ACLK0[2:0]	Select the clocking source for Analog Clock 0. 000b Digital Basic Block 00 001b Digital Basic Block 01 010b Digital Communication Block 02 011b Digital Communication Block 03 100b Digital Basic Block 10, Reserved for CY8C21x23 101b Digital Basic Block 11, Reserved for CY8C21x23 110b Digital Communication Block 12, Reserved for CY8C21x23 111b Digital Communication Block 13, Reserved for CY8C21x23

13.3.12 ABF_CR0

Analog Output Buffer Control Register 0

Individual Register Names and Addresses:

ABF_CR0: 1,62h

4 COLUMN	7	6	5	4	3	2	1	0
Access : POR	RW : 0	RW : 0	RW : 0	RW : 0	RW : 0	RW : 0	RW : 0	RW : 0
Bit Name	ACol1Mux	ACol2Mux	ABUF1EN	ABUF2EN	ABUF0EN	ABUF3EN	Bypass	PWR

2 COLUMN	7	6	5	4	3	2	1	0
Access : POR	RW : 0		RW : 0		RW : 0		RW : 0	RW : 0
Bit Name	ACol1Mux		ABUF1EN		ABUF0EN		Bypass	PWR

2L* Column	7	6	5	4	3	2	1	0
Access : POR	RW : 0							
Bit Name	ACol1Mux							

* This table shows the two column limited functionality of the CY8C21x34, CY8C21x23, CY7C603xx, and CYWUSB6953 PSoC devices for this register.

1 COLUMN	7	6	5	4	3	2	1	0
Access : POR	RW : 0		RW : 0				RW : 0	RW : 0
Bit Name	ACol1Mux		ABUF1EN				Bypass	PWR

This register controls analog input muxes from Port 0.

In the tables above, note that reserved bits are grayed table cells and are not described in the bit description section below. Reserved bits should always be written with a value of '0'. For additional information, refer to the "Register Definitions" on page 112 in the Analog Output Drivers chapter or the "Register Definitions" on page 408 in the Analog Input Configuration chapter.

Bits	Name	Description
7	ACol1Mux	0 Set column 1 input to column 1 input mux output. (1 Column: selects among P0[6,4,2,0]) 1 Set column 1 input to column 0 input mux output. (1 Column: selects among P0[7,5,3,1])
6	ACol2Mux	0 Set column 2 input to column 2 input mux output. 1 Set column 2 input to column 3 input mux output.
5	ABUF1EN	Enables the analog output buffer for Analog Column 1 (Pin P0[5]). 0 Disable analog output buffer. 1 Enable analog output buffer.
4	ABUF2EN	Enables the analog output buffer for Analog Column 2 (Pin P0[4]). 0 Disable analog output buffer. 1 Enable analog output buffer.
3	ABUF0EN	Enables the analog output buffer for Analog Column 0 (Pin P0[3]). (1 Column: AGND) 0 Disable analog output buffer. 1 Enable analog output buffer.

(continued on next page)

13.3.12 ABF_CR0 (continued)

2	ABUF3EN	Enables the analog output buffer for Analog Column 3 (Pin P0[2]). 0 Disable analog output buffer. 1 Enable analog output buffer.
1	Bypass	Connects the positive input of the amplifier(s) directly to the output(s). Amplifiers must be disabled when in Bypass mode. 0 Disable 1 Enable
0	PWR	Determines power level of all output buffers. 0 Low output power 1 High output power

13.3.13 AMD_CR0

Analog Modulation Control Register 0

Individual Register Names and Addresses:

AMD_CR0: 1,63h

4 COLUMN	7	6	5	4	3	2	1	0
Access : POR			RW : 0			RW : 0		
Bit Name		AMOD2[2:0]					AMOD0[2:0]	

2 COLUMN	7	6	5	4	3	2	1	0
Access : POR						RW : 0		
Bit Name						AMOD0[2:0]		

2L* Column	7	6	5	4	3	2	1	0
Access : POR					RW : 0			
Bit Name					AMOD0[3:0]			

* This table shows the two column limited functionality of the CY8C21x34, CY8C21x23, CY7C603xx, and CYWUSB6953 PSoC devices for this register.

This register is used to select the modulator bits used with each column.

This register is only for 4 and 2 column analog PSoC devices. Use the register tables above, in addition to the detailed register bit descriptions below, to determine which bits are reserved for some smaller PSoC devices. In the table above, note that reserved bits are grayed table cells and are not described in the bit description section below. Reserved bits should always be written with a value of '0'. For additional information, refer to the "Register Definitions" on page 386 in the Analog Interface chapter.

Bits	Name	Description
6:4	AMOD2[2:0]	Analog modulation control signal selection for column 2. 000b Zero (off) 001b Global Output Bus, even bus bit 1 (GOE[1]) 010b Global Output Bus, even bus bit 0 (GOE[0]) 011b Row 0 Broadcast Bus 100b Analog Column Comparator 0 101b Analog Column Comparator 1 110b Analog Column Comparator 2 111b Analog Column Comparator 3
2:0	AMOD0[2:0]	Analog modulation control signal selection for column 0. 000b Zero (off) 001b Global Output Bus, even bus bit 1 (GOE[1]) 010b Global Output Bus, even bus bit 0 (GOE[0]) 011b Row 0 Broadcast Bus 100b Analog Column Comparator 0 101b Analog Column Comparator 1 110b Analog Column Comparator 2 111b Analog Column Comparator 3

(continued on next page)

13.3.13 AMD_CR0 (continued)

3:0	AMOD0[3:0]	<p>These bits are specific to the CY8C21x34, CY8C21x23, CY7C603xx, and CYWUSB6953 PSoC devices. These devices are two column limited analog devices.</p> <p>0000b Zero (off)</p> <p>0001b Global Output Bus, even bus bit 1 (GOE[1])</p> <p>0010b Global Output Bus, even bus bit 0 (GOE[0])</p> <p>0011b Row 0 Broadcast Bus</p> <p>0100b Analog Column Comparator 0</p> <p>0101b Analog Column Comparator 1</p> <p>0110b Analog Column Comparator 2</p> <p>0111b Analog Column Comparator 3</p> <p>1000b Reserved</p> <p>1001b Reserved</p> <p>1010b Reserved</p> <p>1011b Reserved</p> <p>1100b Analog Column Comparator 0, single synchronized</p> <p>1101b Analog Column Comparator 1, single synchronized</p> <p>1110b Reserved</p> <p>1111b Reserved</p>
------------	-------------------	---

13.3.14 CMP_GO_EN

Comparator Bus to Global Outputs Enable Register

Individual Register Names and Addresses:

CMP_GO_EN: 1,64h

2L* Column	7	6	5	4	3	2	1	0
Access : POR	RW : 0	RW : 0	RW : 0		RW : 0	RW : 0	RW : 0	
Bit Name	GOO5	GOO1	SEL1[1:0]		GOO4	GOO0	SEL0[1:0]	

* This table shows the two column limited functionality of the CY8C21x34, CY8C21x23, CY7C603xx, and CYWUSB6953 PSoC devices and the two column analog functionality of the CY8C24x94 and CY&c64215 PSoC devices.

This register controls options for driving the analog comparator bus and column clock to the global bus.

This register is only used by the CY8C24x94, CY8C21x34, CY8C21x23, CY7C64215, CY7C603xx, and CYWUSB6953 PSoC devices. For additional information, refer to the “[Register Definitions](#)” on page 443 in the Two Column Limited Analog System chapter.

Bits	Name	Description
7	GOO5	Drives the selected column 1 signal to GOO5.
6	GOO1	Drives the selected column 1 signal to GOO1.
5:4	SEL1[1:0]	Selects the column 1 signal to output. Two Column Limited Analog 00b Comparator bus output 01b Column clock 10b Comparator output after single sync 11b Column clock gated with the synchronized comparator bus USB Two Column Analog 00b Comparator bus output 01b PHI1 column clock 10b PHI2 column clock 11b Selected column clock direct (1X)
3	GOO4	Drives the selected column 0 signal to GOO4.
2	GOO0	Drives the selected column 0 signal to GOO0.
1:0	SEL0[1:0]	Selects the column 0 signal to output. Two Column Limited Analog 00b Comparator bus output 01b Column clock 10b ADC PWM output 11b Column clock gated with the synchronized comparator bus USB Two Column Analog 00b Comparator bus output 01b PHI1 column clock 10b PHI2 column clock 11b Selected column clock direct (1X)

1,65h

13.3.15 CMP_GO_EN1

Comparator Bus to Global Outputs Enable Register 1

Individual Register Names and Addresses:

CMP_GO_EN1: 1,65h

	7	6	5	4	3	2	1	0
Access : POR	RW : 0	RW : 0	RW : 0		RW : 0	RW : 0	RW : 0	
Bit Name	GOO7	GOO3	SEL3[1:0]		GOO6	GOO2	SEL2[1:0]	

This register controls options for driving the analog comparator bus and column clock to the global bus.

This register is only used by the CY8C24x94 and CY7C64215 PSoC devices. For additional information, refer to the “Register Definitions” on page 386 in the Analog Interface chapter.

Bits	Name	Description
7	GOO7	Drives the selected column 3 signal to GOO7.
6	GOO3	Drives the selected column 3 signal to GOO3.
5:4	SEL3[1:0]	Selects the column 3 signal to output. 00b Comparator bus output. (Tied low in the CY8C24x94 and CY7C64215.) 01b PHI1 column clock. 10b PHI2 column clock. 11b PHI1 unsynchronized comparator bus.
3	GOO6	Drives the selected column 2 signal to GOO6.
2	GOO2	Drives the selected column 2 signal to GOO2.
1:0	SEL2[1:0]	Selects the column 2 signal to output. 00b Comparator bus output. (Tied low in the CY8C24x94 and CY7C64215.) 01b PHI1 column clock. 10b PHI2 column clock. 11b PHI1 unsynchronized comparator bus.

13.3.16 AMD_CR1

Analog Modulation Control Register 1

Individual Register Names and Addresses:

AMD_CR1: 1,66h

4 COLUMN	7	6	5	4	3	2	1	0
Access : POR			RW : 0				RW : 0	
Bit Name			AMOD3[2:0]				AMOD1[2:0]	

2 COLUMN	7	6	5	4	3	2	1	0
Access : POR							RW : 0	
Bit Name							AMOD1[2:0]	

2L* Column	7	6	5	4	3	2	1	0
Access : POR							RW : 0	
Bit Name							AMOD1[3:0]	

* This table shows the two column limited functionality of the CY8C21x34, CY8C21x23, CY7C603xx, and CYWUSB6953 PSoC devices for this register.

This register is used to select the modulator bits used with each column.

This register is only for 4 and 2 column analog PSoC devices. Use the register tables above, in addition to the detailed register bit descriptions below, to determine which bits are reserved for some smaller PSoC devices. Note that reserved bits are grayed table cells and are not described in the bit description section. Reserved bits should always be written with a value of '0'. For additional information, refer to the "Register Definitions" on page 386 in the Analog Interface chapter.

Bits	Name	Description
6:4	AMOD3[2:0]	Analog modulation control signal selection for column 3. 000b Zero (off) 001b Global Output Bus, even bus bit 1 (GOE[1]) 010b Global Output Bus, even bus bit 0 (GOE[0]) 011b Row 0 Broadcast Bus 100b Analog Column Comparator 0 101b Analog Column Comparator 1 110b Analog Column Comparator 2 111b Analog Column Comparator 3
2:0	AMOD1[2:0]	Analog modulation control signal selection for column 1. 000b Zero (off) 001b Global Output Bus, even bus bit 1 (GOE[1]) 010b Global Output Bus, even bus bit 0 (GOE[0]) 011b Row 0 Broadcast Bus 100b Analog Column Comparator 0 101b Analog Column Comparator 1 110b Analog Column Comparator 2 111b Analog Column Comparator 3

(continued on next page)

13.3.16 AMD_CR1 (continued)

3:0	AMOD1[3:0]	<p>These bits are specific to the CY8C21x34, CY8C21x23, CY7C603xx, and CYWUSB6953 PSoC devices. These devices are two column limited analog devices.</p> <p>0000b Zero (off)</p> <p>0001b Global Output Bus, even bus bit 1 (GOE[1])</p> <p>0010b Global Output Bus, even bus bit 0 (GOE[0])</p> <p>0011b Row 0 Broadcast Bus</p> <p>0100b Analog Column Comparator 0</p> <p>0101b Analog Column Comparator 1</p> <p>0110b Analog Column Comparator 2</p> <p>0111b Analog Column Comparator 3</p> <p>1000b Reserved</p> <p>1001b Reserved</p> <p>1010b Reserved</p> <p>1011b Reserved</p> <p>1100b Analog Column Comparator 0, single synchronized</p> <p>1101b Analog Column Comparator 1, single synchronized</p> <p>1110b Reserved</p> <p>1111b Reserved</p>
------------	-------------------	---

13.3.17 ALT_CR0

Analog LUT Control Register 0

Individual Register Names and Addresses:

ALT_CR0: 1,67h

4, 2 COLUMN	7	6	5	4	3	2	1	0
Access : POR	RW : 0				RW : 0			
Bit Name	LUT1[3:0]				LUT0[3:0]			

2L* Column	7	6	5	4	3	2	1	0
Access : POR	RW : 0				RW : 0			
Bit Name	LUT1[3:0]				LUT0[3:0]			

* This table shows the two column limited functionality of the CY8C21x34, CY8C21x23, CY7C603xx, and CYWUSB6953 PSoC devices for this register.

1 COLUMN	7	6	5	4	3	2	1	0
Access : POR	RW : 0							
Bit Name	LUT1[3:0]							

This register is used to select the logic function.

Use the register tables above, in addition to the detailed register bit descriptions below, to determine which bits are reserved for some smaller PSoC devices. Note that reserved bits are grayed table cells and are not described in the bit description section. Reserved bits should always be written with a value of '0'. For additional information, refer to the "Register Definitions" on page 386 in the Analog Interface chapter.

Bits	Name	Description																																		
7:4	LUT1[3:0]	Select 1 of 16 logic functions for output of comparator bus 1. For a 1 column device, LUT input B=0. <table border="0" style="margin-left: 20px;"> <thead> <tr> <th colspan="2">Function</th> </tr> </thead> <tbody> <tr><td>0h</td><td>FALSE</td></tr> <tr><td>1h</td><td>A AND B</td></tr> <tr><td>2h</td><td>A AND \bar{B}</td></tr> <tr><td>3h</td><td>A</td></tr> <tr><td>4h</td><td>\bar{A} AND B</td></tr> <tr><td>5h</td><td>B</td></tr> <tr><td>6h</td><td>A XOR B</td></tr> <tr><td>7h</td><td>A OR B</td></tr> <tr><td>8h</td><td>A NOR B</td></tr> <tr><td>9h</td><td>\bar{A} XNOR B</td></tr> <tr><td>Ah</td><td>\bar{B}</td></tr> <tr><td>Bh</td><td>A OR \bar{B}</td></tr> <tr><td>Ch</td><td>\bar{A}</td></tr> <tr><td>Dh</td><td>\bar{A} OR B</td></tr> <tr><td>Eh</td><td>A NAND B</td></tr> <tr><td>Fh</td><td>TRUE</td></tr> </tbody> </table>	Function		0h	FALSE	1h	A AND B	2h	A AND \bar{B}	3h	A	4h	\bar{A} AND B	5h	B	6h	A XOR B	7h	A OR B	8h	A NOR B	9h	\bar{A} XNOR B	Ah	\bar{B}	Bh	A OR \bar{B}	Ch	\bar{A}	Dh	\bar{A} OR B	Eh	A NAND B	Fh	TRUE
Function																																				
0h	FALSE																																			
1h	A AND B																																			
2h	A AND \bar{B}																																			
3h	A																																			
4h	\bar{A} AND B																																			
5h	B																																			
6h	A XOR B																																			
7h	A OR B																																			
8h	A NOR B																																			
9h	\bar{A} XNOR B																																			
Ah	\bar{B}																																			
Bh	A OR \bar{B}																																			
Ch	\bar{A}																																			
Dh	\bar{A} OR B																																			
Eh	A NAND B																																			
Fh	TRUE																																			

(continued on next page)

13.3.17 ALT_CR0 (continued)

3:0 LUT0[3:0] Select 1 of 16 logic functions for output of comparator bus 0.

	Function
0h	FALSE
1h	A AND B
2h	A AND B
3h	A
4h	\bar{A} AND B
5h	B
6h	A XOR B
7h	A OR B
8h	A NOR B
9h	A XNOR B
Ah	\bar{B}
Bh	\bar{A} OR \bar{B}
Ch	\bar{A}
Dh	\bar{A} OR B
Eh	A NAND B
Fh	TRUE

13.3.18 ALT_CR1

Analog LUT Control Register 1

Individual Register Names and Addresses:

ALT_CR1: 1,68h

4 COLUMN	7	6	5	4	3	2	1	0
Access : POR	RW : 0				RW : 0			
Bit Name	LUT3[3:0]				LUT2[3:0]			

This register is used to select the logic function performed by the LUT for each analog column.

This register is for 4 column PSoC devices only. For additional information, refer to the “[Register Definitions](#)” on page 386 in the Analog Interface chapter.

Bits	Name	Description
7:4	LUT3[3:0]	Select 1 of 16 logic functions for output of comparator bus 3. Function 0h FALSE 1h A AND B 2h A AND \bar{B} 3h \bar{A} 4h \bar{A} AND B 5h B 6h A XOR B 7h A OR B 8h A NOR B 9h \bar{A} XNOR B Ah \bar{B} Bh \bar{A} OR \bar{B} Ch \bar{A} Dh \bar{A} OR B Eh A NAND B Fh TRUE
3:0	LUT2[3:0]	Select 1 of 16 logic functions for output of comparator bus 2. Function 0h FALSE 1h A AND B 2h A AND \bar{B} 3h \bar{A} 4h \bar{A} AND B 5h B 6h A XOR B 7h A OR B 8h A NOR B 9h \bar{A} XNOR B Ah \bar{B} Bh \bar{A} OR \bar{B} Ch \bar{A} Dh \bar{A} OR B Eh A NAND B Fh TRUE

13.3.19 CLK_CR2

Analog Clock Source Control Register 2

Individual Register Names and Addresses:

CLK_CR2: 1,69h

4 COLUMN	7	6	5	4	3	2	1	0
Access : POR					RW : 0			RW : 0
Bit Name					ACLK1R			ACLK0R

This register, in conjunction with the CLK_CR1 and CLK_CR0 registers, selects a digital block as a source for analog column clocking.

This register is for 4 column PSoC devices only. These bits extend the range of the Digital PSoC blocks that may be selected for the analog clock source in CLK_CR1 from eight to 16. In the table above, note that reserved bits are grayed table cells and are not described in the bit description section below. Reserved bits should always be written with a value of '0'. For additional information, refer to the ["Register Definitions"](#) on page 386 in the Analog Interface chapter.

Bits	Name	Description
3	ACLK1R	Analog Clock 1 Selection Range 0 Select Digital PSoC Block, from row 0 and 1 (00-13). 1 Select Digital PSoC Block, from row 2 and 3 (20-33).
0	ACLK0R	Analog Clock 0 Selection Range 0 Select Digital PSoC Block, from row 0 and 1 (00-13). 1 Select Digital PSoC Block, from row 2 and 3 (20-33).

13.3.20 CLK_CR3

Analog Clock Source Control Register 3

Individual Register Names and Addresses:

CLK_CR3: 1,6Bh

2L* Column	7	6	5	4	3	2	1	0
Access : POR		RW : 0		RW : 0		RW : 0		RW : 0
Bit Name		SYS1		DIVCLK1[1:0]		SYS0		DIVCLK0[1:0]

* This table shows the two column limited functionality of the CY8C21x34, CY8C21x23, CY7C603xx, and CYWUSB6953 PSoC devices for this register.

This register controls additional options for analog column clock generation.

This register is only used by the CY8C21x34, CY8C21x23, CY7C603xx, and CYWUSB6953 PSoC devices. In the table above, note that reserved bits are grayed table cells and are not described in the bit description section below. Reserved bits should always be written with a value of '0'. For additional information, refer to the “[Register Definitions](#)” on page 443 in the Two Column Limited Analog System chapter.

Bits	Name	Description
6	SYS1	0 Column 1 clock selection is controlled by CLK_CR0. 1 Column 1 clock selection is SYSCLK direct.
5:4	DIVCLK1[1:0]	00b No divide on selected column 1 clock. 01b Divide by 2 on selected column 1 clock. 10b Divide by 4 on selected column 1 clock. 11b Divide by 8 on selected column 1 clock.
2	SYS0	0 Column 0 clock selection is controlled by CLK_CR0. 1 Column 0 clock selection is SYSCLK direct.
1:0	DIVCLK0[1:0]	00b No divide on selected column 0 clock. 01b Divide by 2 on selected column 0 clock. 10b Divide by 4 on selected column 0 clock. 11b Divide by 8 on selected column 0 clock.

13.3.21 AMUX_CLK

Analog Mux Clock Register

Individual Register Names and Addresses:

AMUX_CLK: 1,AFh

2 Column	7	6	5	4	3	2	1	0
Access : POR							RW : 0	
Bit Name							CLKSYNC[1:0]	

This register is used to adjust the phase of the clock to the analog mux bus.

This register is only used by the CY8C24x94 and CY7C64215 PSoC devices. In the table above, note that reserved bits are grayed table cells and are not described in the bit description section below. Reserved bits should always be written with a value of '0'. For additional information, refer to the “[Register Definitions](#)” on page 443 in the Two Column Limited Analog System chapter.

Bits	Name	Description
1:0	CLKSYNC[1:0]	<p>Synchronizes the MUXCLK. The MUXCLK that drives switching on the analog mux can be synchronized to one of four phases, as listed below. These settings can be used to optimize noise performance by varying the analog mux sampling point relative to the system clock.</p> <p>00b Synchronize to SYSCLK rising edge 01b Synchronize to delayed (approximately 5 ns) SYSCLK rising edge 10b Synchronize to SYSCLK falling edge 11b Synchronize to early (approximately 5 ns) SYSCLK rising edge</p>

13.3.22 USB_CR1

USB Control Register 1

Individual Register Names and Addresses:

USB_CR1 : 1,C1h

	7	6	5	4	3	2	1	0
Access : POR						RC : 0	RW : 0	RW : 0
Bit Name						BusActivity	EnableLock	RegEnable

This register is used to configure the internal regulator and the oscillator tuning capability.

This register is only used by the CY8C24x94 and CY7C64215 PSoC devices. Reserved bits are grayed table cells and are not described in the bit description section below. Reserved bits should always be written with a value of '0'. For additional information, refer to the "Register Definitions" on page 529 in the Full-Speed USB chapter.

Bit	Name	Description
2	BusActivity	Monitors activity on USB bus. This bit can only be set by the hardware. Writing a '0' clears this bit. Writing a '1' preserves its present state. 0 No activity. 1 Non-idle activity (D+ = Low) was detected since the last time the bit was cleared.
1	EnableLock	Controls the automatic tuning of the internal oscillator. Hardware will lock the internal oscillator based on the frequency of incoming USB data when this bit is set. Normally, this should be set unless an accurate external clock is used. 0 Locking disabled. 1 Locking enabled.
0	RegEnable	Configures USB regulator for appropriate power supply range. 0 Pass-through mode. Use for Vdd = 3.3V range. (Vdd ≤ 3.6V) 1 Regulating mode. Use for Vdd = 5V range. (Vdd > 4.5V) This is normally used for bus-powered settings.

13.3.23 EPx_CR0

Endpoint Control Register 0

Individual Register Names and Addresses:

EP1_CR0 : 1,C4h

EP2_CR0 : 1,C5h

EP3_CR0 : 1,C6h

EP4_CR0 : 1,C7h

	7	6	5	4	3	2	1	0
Access : POR	RW : 0		RW : 0	RC : 0				RW : 00
Bit Name	Stall		NAK Int Enable	ACK'd Transaction				Mode[3:0]

This register is used for status and configuration of the non-control endpoints.

This register is only used by the CY8C24x94 and CY7C64215 PSoC devices. Reserved bits are grayed table cells and are not described in the bit description section below. Reserved bits should always be written with a value of '0'. For additional information, refer to the "Register Definitions" on page 529 in the Full-Speed USB chapter.

Bit	Name	Description
7	Stall	This bit is used to issue a stall on certain USB transactions. 0 Do not issue a stall on the conditions listed below. 1 Stall an OUT packet if mode bits are set to ACK-OUT, or Stall an IN packet if mode bits are set to ACK-IN.
5	NAK Int Enable	Determines if NAKs on this endpoint will assert an interrupt. 0 Do not issue an interrupt on NAK. 1 Interrupt on NAK.
4	ACK'd Transaction	This bit is set by the SIE whenever a transaction to the endpoint completes with an ACK. This bit is cleared by any writes to the register. 0 No ACK'd transactions since bit was last cleared. 1 Indicates a transaction ended with an ACK.
3:0	Mode[3:0]	The mode controls how the USB SIE responds to traffic and how the USB SIE will change the mode of that endpoint as a result of host packets to the endpoint. Refer to the table titled "Mode Encoding for Control and Non-Control Endpoints" on page 524.

13.3.24 GDI_O_IN

Global Digital Interconnect Odd Inputs Register

Individual Register Names and Addresses:

GDI_O_IN: 1,D0h

	7	6	5	4	3	2	1	0
Access : POR	RW : 0	RW : 0	RW : 0	RW : 0	RW : 0	RW : 0	RW : 0	RW : 0
Bit Name	GIONOUT7	GIONOUT6	GIONOUT5	GIONOUT4	GIONOUT3	GIONOUT2	GIONOUT1	GIONOUT0

This register is used to configure a global input to drive a global output.

For additional information, refer to the “[Register Definitions](#)” on [page 323](#) in the Global Digital Interconnect chapter.

Bit	Name	Description
7	GIONOUT7	0 GIO[7] does not drive GOO[7].
		1 GIO[7] drives its value on to GOO[7].
6	GIONOUT6	0 GIO[6] does not drive GOO[6].
		1 GIO[6] drives its value on to GOO[6].
5	GIONOUT5	0 GIO[5] does not drive GOO[5].
		1 GIO[5] drives its value on to GOO[5].
4	GIONOUT4	0 GIO[4] does not drive GOO[4].
		1 GIO[4] drives its value on to GOO[4].
3	GIONOUT3	0 GIO[3] does not drive GOO[3].
		1 GIO[3] drives its value on to GOO[3].
2	GIONOUT2	0 GIO[2] does not drive GOO[2].
		1 GIO[2] drives its value on to GOO[2].
1	GIONOUT1	0 GIO[1] does not drive GOO[1].
		1 GIO[1] drives its value on to GOO[1].
0	GIONOUT0	0 GIO[0] does not drive GOO[0].
		1 GIO[0] drives its value on to GOO[0].

13.3.25 GDI_E_IN

Global Digital Interconnect Even Inputs Register

Individual Register Names and Addresses:

GDI_E_IN: 1,D1h

	7	6	5	4	3	2	1	0
Access : POR	RW : 0	RW : 0	RW : 0	RW : 0	RW : 0	RW : 0	RW : 0	RW : 0
Bit Name	GIENOUT7	GIENOUT6	GIENOUT5	GIENOUT4	GIENOUT3	GIENOUT2	GIENOUT1	GIENOUT0

This register is used to configure a global input to drive a global output.

For additional information, refer to the “[Register Definitions](#)” on page 323 in the Global Digital Interconnect chapter.

Bit	Name	Description
7	GIENOUT7	0 GIE[7] does not drive GOE[7]. 1 GIE[7] drives its value on to GOE [7].
6	GIENOUT6	0 GIE[6] does not drive GOE[6]. 1 GIE[6] drives its value on to GOE [6].
5	GIENOUT5	0 GIE[5] does not drive GOE[5]. 1 GIE[5] drives its value on to GOE [5].
4	GIENOUT4	0 GIE[4] does not drive GOE[4]. 1 GIE[4] drives its value on to GOE [4].
3	GIENOUT3	0 GIE[3] does not drive GOE[3]. 1 GIE[3] drives its value on to GOE [3].
2	GIENOUT2	0 GIE[2] does not drive GOE[2]. 1 GIE[2] drives its value on to GOE [2].
1	GIENOUT1	0 GIE[1] does not drive GOE[1]. 1 GIE[1] drives its value on to GOE [1].
0	GIENOUT0	0 GIE[0] does not drive GOE[0]. 1 GIE[0] drives its value on to GOE [0].

13.3.26 GDI_O_OU

Global Digital Interconnect Odd Outputs Register

Individual Register Names and Addresses:

GDI_O_OU: 1,D2h

	7	6	5	4	3	2	1	0
Access : POR	RW : 0	RW : 0	RW : 0	RW : 0	RW : 0	RW : 0	RW : 0	RW : 0
Bit Name	GOOUTIN7	GOOUTIN6	GOOUTIN5	GOOUTIN4	GOOUTIN3	GOOUTIN2	GOOUTIN1	GOOUTIN0

This register is used to configure a global output to drive a global input.

For additional information, refer to the “[Register Definitions](#)” on page 323 in the Global Digital Interconnect chapter.

Bit	Name	Description	
7	GOOUTIN7	0	GOO[7] does not drive GIO[7].
		1	GOO[7] drives its value on to GIO[7].
6	GOOUTIN6	0	GOO[6] does not drive GIO[6].
		1	GOO[6] drives its value on to GIO[6].
5	GOOUTIN5	0	GOO[5] does not drive GIO[5].
		1	GOO[5] drives its value on to GIO[5].
4	GOOUTIN4	0	GOO[4] does not drive GIO[4].
		1	GOO[4] drives its value on to GIO[4].
3	GOOUTIN3	0	GOO[3] does not drive GIO[3].
		1	GOO[3] drives its value on to GIO[3].
2	GOOUTIN2	0	GOO[2] does not drive GIO[2].
		1	GOO[2] drives its value on to GIO[2].
1	GOOUTIN1	0	GOO[1] does not drive GIO[1].
		1	GOO[1] drives its value on to GIO[1].
0	GOOUTIN0	0	GOO[0] does not drive GIO[0].
		1	GOO[0] drives its value on to GIO[0].

13.3.27 GDI_E_OU

Global Digital Interconnect Even Outputs Register

Individual Register Names and Addresses:

GDI_E_OU: 1,D3h

	7	6	5	4	3	2	1	0
Access : POR	RW : 0	RW : 0	RW : 0	RW : 0	RW : 0	RW : 0	RW : 0	RW : 0
Bit Name	GOEUTIN7	GOEUTIN6	GOEUTIN5	GOEUTIN4	GOEUTIN3	GOEUTIN2	GOEUTIN1	GOEUTIN0

This register is used to configure a global output to drive a global input.

For additional information, refer to the “[Register Definitions](#)” on page 323 in the Global Digital Interconnect chapter.

Bit	Name	Description
7	GOEUTIN7	0 GOE[7] does not drive GIE[7]. 1 GOE[7] drives its value on to GIE[7].
6	GOEUTIN6	0 GOE[6] does not drive GIE[6]. 1 GOE[6] drives its value on to GIE[6].
5	GOEUTIN5	0 GOE[5] does not drive GIE[5]. 1 GOE[5] drives its value on to GIE[5].
4	GOEUTIN4	0 GOE[4] does not drive GIE[4]. 1 GOE[4] drives its value on to GIE[4].
3	GOEUTIN3	0 GOE[3] does not drive GIE[3]. 1 GOE[3] drives its value on to GIE[3].
2	GOEUTIN2	0 GOE[2] does not drive GIE[2]. 1 GOE[2] drives its value on to GIE[2].
1	GOEUTIN1	0 GOE[1] does not drive GIE[1]. 1 GOE[1] drives its value on to GIE[1].
0	GOEUTIN0	0 GOE[0] does not drive GIE[0]. 1 GOE[0] drives its value on to GIE[0].

13.3.28 MUX_CRx

Analog Mux Port Bit Enables Register

Individual Register Names and Addresses:

MUX_CR0 : 1,D8h MUX_CR1 : 1,D9h MUX_CR2 : 1,DAh MUX_CR3 : 1,DBh
 MUX_CR4 : 1,ECh MUX_CR5 : 1,EDh

	7	6	5	4	3	2	1	0
Access : POR	RW : 00							
Bit Name	ENABLE[7:0]							

This register is used to control the connection between the analog mux bus and the corresponding pin.

This register is only used by the CY8C24x94, CY8C21x34, CY7C64215, CY7C603xx, and CYWUSB6953 PSoC devices. The CY8C21x34, CY7C603xx, and CYWUSB6953 have a 4-bit wide Port 3 and the upper 4 bits of the MUX_CR3 register are reserved and will return zeros when read. The MUX_CRx registers with addresses 1,ECh and 1,EDh are used by the CY8C24x94 and CY7C64215 PSoC devices. For additional information, refer to the “Register Definitions” on page 521 in the IO Analog Multiplexer chapter.

Bits	Name	Description
7:0	ENABLE[7:0]	Each bit controls the connection between the analog mux bus and the corresponding port pin. For example, MUX_CR2[3] controls the connection to bit 3 in Port 2. Any number of pins may be connected at the same time. Note that if a precharge clock is selected in the AMUX_CFG register, the connection to the mux bus will be switched on and off under hardware control. 0 No connection between port pin and analog mux bus. 1 Connect port pin to analog mux bus.

13.3.29 OSC_GO_EN

Oscillator to Global Outputs Enable Register

Individual Register Names and Addresses:

OSC_GO_EN: 1,DDh

	7	6	5	4	3	2	1	0
Access : POR	RW : 0	RW : 0	RW : 0	RW : 0	RW : 0	RW : 0	RW : 0	RW : 0
Bit Name	SLPINT	VC3	VC2	VC1	SYCLKX2	SYCLK	CLK24M	CLK32K

This register is used to enable tri-state buffers that connect specific system clocks to specific global output even nets.

For additional information, refer to the “[Register Definitions](#)” on page 463 in the Digital Clocks chapter. Also refer to the “[PSoC Device Distinctions](#)” on page 462, in the Digital Clocks chapter, for more information on availability of the OSC_GO_EN register bits.

Bit	Name	Description
7	SLPINT	0 The sleep interrupt is not driven onto a global net. 1 The sleep interrupt is driven onto GOE[7].
6	VC3	0 The VC3 clock is not driven onto a global net 1 The VC3 clock is driven onto GOE[6]
5	VC2	0 The VC2 clock is not driven onto a global net 1 The VC2 clock is driven onto GOE[5]
4	VC1	0 The VC1 clock is not driven onto a global net 1 The VC1 clock is driven onto GOE[4]
3	SYCLKX2	0 The 2 times system clock is not driven onto a global net 1 The 2 times system clock is driven onto GOE[3]
2	SYCLK	0 The system clock is not driven onto a global net 1 The system clock is driven onto GOE[2]
1	CLK24M	0 The 24 MHz clock is not driven onto a global net 1 The 24 MHz system clock is driven onto GOE[1]
0	CLK32K	0 The 32 kHz clock is not driven onto a global net 1 The 32 kHz system clock is driven onto GOE[0]

13.3.30 OSC_CR4

Oscillator Control Register 4

Individual Register Names and Addresses:

OSC_CR4: 1,DEh

	7	6	5	4	3	2	1	0
Access : POR							RW : 0	
Bit Name							VC3 Input Select[1:0]	

This register selects the input clock to variable clock 3 (VC3).

In the table above, note that reserved bits are grayed table cells and are not described in the bit description section below. Reserved bits should always be written with a value of '0'. For additional information, refer to the "Register Definitions" on page 463 in the Digital Clocks chapter.

Bit	Name	Description
1:0	VC3 Input Select[1:0]	Selects the clocking source for the VC3 Clock Divider. 00b SYSCLK 01b VC1 10b VC2 11b SYSCLKX2

13.3.31 OSC_CR3

Oscillator Control Register 3

Individual Register Names and Addresses:

OSC_CR3: 1,DFh

	7	6	5	4	3	2	1	0
Access : POR	RW : 00							
Bit Name	VC3 Divider[7:0]							

This register selects the divider value for variable clock 3 (VC3).

The output frequency of the VC3 Clock Divider is the input frequency divided by the value in this register, plus one. For example, if this register contains 07h, the clock frequency output from the VC3 Clock Divider will be one eighth the input frequency. For additional information, refer to the “[Register Definitions](#)” on page 463 in the Digital Clocks chapter.

Bit	Name	Description
7:0	VC3 Divider[7:0]	Refer to the OSC_CR4 register. 00h Input Clock 01h Input Clock / 2 02h Input Clock / 3 03h Input Clock / 4 ... FCh Input Clock / 253 FDh Input Clock / 254 FEh Input Clock / 255 FFh Input Clock / 256

13.3.32 OSC_CR0

Oscillator Control Register 0

Individual Register Names and Addresses:

OSC_CR0: 1,E0h

	7	6	5	4	3	2	1	0
Access : POR	RW : 0	RW : 0	RW : 0	RW : 0		RW : 0		
Bit Name	32k Select	PLL Mode	No Buzz	Sleep[1:0]		CPU Speed[2:0]		

This register is used to configure various features of internal clock sources and clock nets.

Bits 7 and 6 in this register cannot be used by the CY8C21xxx, CY8C24x94, and CY7C64215 PSoC devices. For additional information, refer to the “Register Definitions” on page 463 in the Digital Clocks chapter.

Bit	Name	Description		
7	32k Select	0 Internal low precision 32 kHz oscillator		
		1 External crystal 32.768 kHz oscillator		
6	PLL Mode	0 Disabled		
		1 Enabled. Internal main oscillator is frequency locked to External Crystal Oscillator.		
5	No Buzz	0 BUZZ bandgap during power down.		
		1 Bandgap is always powered even during sleep.		
4:3	Sleep[1:0]	Sleep Interval		
		00b 1.95 ms (512 Hz)		
		01b 15.6 ms (64 Hz)		
		10b 125 ms (8 Hz)		
		11b 1 s (1 Hz)		
2:0	CPU Speed[2:0]	These bits set the CPU clock speed, based on the system clock (SYSCLK). SYSCLK is 24 MHz by default, but it can optionally be set to 6 MHz on some PSoC devices (see the “Architectural Description” on page 113), or driven from an external clock.		
		6 MHz IMO 24 MHz IMO External Clock		
		000b 750 kHz 3 MHz EXTCLK / 8		
		001b 1.5 MHz 6 MHz EXTCLK / 4		
		010b 3 MHz 12 MHz EXTCLK / 2		
		011b 6 MHz 24 MHz EXTCLK / 1		
		100b 375 kHz 1.5 MHz EXTCLK / 16		
		101b 187.5 kHz 750 kHz EXTCLK / 32		
		110b 46.9 kHz 187.5 kHz EXTCLK / 128		
		111b 23.4 kHz 93.7 kHz EXTCLK / 256		
				Not available for CY7C603xx due to lower operating voltage.

13.3.33 OSC_CR1

Oscillator Control Register 1

Individual Register Names and Addresses:

OSC_CR1: 1,E1h

	7	6	5	4	3	2	1	0
Access : POR	RW : 0				RW : 0			
Bit Name	VC1 Divider[3:0]				VC2 Divider[3:0]			

This register selects the divider value for variable clocks 1 and 2 (VC1 and VC2).

For additional information, refer to the “[Register Definitions](#)” on page 463 in the Digital Clocks chapter.

Bit	Name	Description
7:4	VC1 Divider[3:0]	Internal Main Oscillator
		0h 24 MHz
		1h 12 MHz
		2h 8 MHz
		3h 6 MHz
		4h 4.8 MHz
		5h 4 MHz
		6h 3.43 MHz
		7h 3 MHz
		8h 2.67 MHz
		9h 2.40 MHz
		Ah 2.18 MHz
		Bh 2.00 MHz
		Ch 1.85 MHz
		Dh 1.71 MHz
		Eh 1.6 MHz
Fh 1.5 MHz		
3:0	VC2 Divider[3:0]	Internal Main Oscillator
		0h $(24 / (\text{OSC_CR1}[7:4]+1)) / 1$
		1h $(24 / (\text{OSC_CR1}[7:4]+1)) / 2$
		2h $(24 / (\text{OSC_CR1}[7:4]+1)) / 3$
		3h $(24 / (\text{OSC_CR1}[7:4]+1)) / 4$
		4h $(24 / (\text{OSC_CR1}[7:4]+1)) / 5$
		5h $(24 / (\text{OSC_CR1}[7:4]+1)) / 6$
		6h $(24 / (\text{OSC_CR1}[7:4]+1)) / 7$
		7h $(24 / (\text{OSC_CR1}[7:4]+1)) / 8$
		8h $(24 / (\text{OSC_CR1}[7:4]+1)) / 9$
		9h $(24 / (\text{OSC_CR1}[7:4]+1)) / 10$
		Ah $(24 / (\text{OSC_CR1}[7:4]+1)) / 11$
		Bh $(24 / (\text{OSC_CR1}[7:4]+1)) / 12$
		Ch $(24 / (\text{OSC_CR1}[7:4]+1)) / 13$
		Dh $(24 / (\text{OSC_CR1}[7:4]+1)) / 14$
		Eh $(24 / (\text{OSC_CR1}[7:4]+1)) / 15$
Fh $(24 / (\text{OSC_CR1}[7:4]+1)) / 16$		
		External Clock
		EXTCLK / 1
		EXTCLK / 2
		EXTCLK / 3
		EXTCLK / 4
		EXTCLK / 5
		EXTCLK / 6
		EXTCLK / 7
		EXTCLK / 8
		EXTCLK / 9
		EXTCLK / 10
		EXTCLK / 11
		EXTCLK / 12
		EXTCLK / 13
		EXTCLK / 14
		EXTCLK / 15
		EXTCLK / 16

13.3.34 OSC_CR2

Oscillator Control Register 2

Individual Register Names and Addresses:

OSC_CR2: 1,E2h

	7	6	5	4	3	2	1	0
Access : POR	RW : 0					RW : 0	RW : 0	RW : 0
Bit Name	PLLGAIN					EXTCLKEN	IMODIS	SYSCLKX2DIS

This register is used to configure various features of internal clock sources and clock nets.

In OCD mode (OCDM=1), bits [1:0] have no effect. In the table above, note that reserved bits are grayed table cells and are not described in the bit description section below. Reserved bits should always be written with a value of '0'. For additional information, refer to the “Register Definitions” on page 463 in the Digital Clocks chapter.

Bit	Name	Description
7	PLLGAIN	Phase-locked loop gain. 0 Recommended value, normal gain. 1 Reduced gain to make PLL more tolerant to noisy or jittery crystal input.
2	EXTCLKEN	External clock mode enable. 0 Disabled. Operate from internal main oscillator. 1 Enabled. Operate from clock supplied at port P1[4].
1	IMODIS	Internal oscillator disable. Can be set to save power when using an external clock on P1[4]. 0 Enabled. Internal oscillator enabled. 1 Disabled, if SYSCLKX2DIS is set (1).
0	SYSCLKX2DIS	48 MHz clock source disable. 0 Enabled. If enabled, system clock net is forced on. 1 Disabled for power reduction.

13.3.35 VLT_CR

Voltage Monitor Control Register

Individual Register Names and Addresses:

VLT_CR: 1,E3h

4, 2 COLUMN	7	6	5	4	3	2	1	0
Access : POR	RW : 0		RW : 0		RW : 0		RW : 0	
Bit Name	SMP		PORLEV[1:0]		LVDTBEN		VM[2:0]	

1 COLUMN	7	6	5	4	3	2	1	0
Access : POR			RW : 0		RW : 0		RW : 0	
Bit Name			PORLEV[1:0]		LVDTBEN		VM[2:0]	

This register is used to set the trip points for POR, LVD, and the supply pump.

Use the register tables above, in addition to the detailed register bit descriptions below, to determine which bits are reserved for some smaller PSoC devices. Note that reserved bits are grayed table cells and are not described in the bit description section. Reserved bits should always be written with a value of '0'. For additional information, refer to the "Register Definitions" on page 513 in the POR and LVD chapter.

Bit	Name	Description
7	SMP	Switch Mode Pump disable for those PSoC devices with this feature. 0 SMP enabled. 1 SMP disabled.
5:4	PORLEV[1:0]	Sets the POR level per the DC electrical specifications in the PSoC device data sheet. See the table titled "PSoC Device Distinctions" on page 23 for PSoC device specific distinctions. 00b POR level for 2.4 V or 3V operation (refer to the PSoC device data sheet) 01b POR level for 3.0V or 4.5V operation (refer to the PSoC device data sheet) 10b POR level for 4.75V operation 11b Reserved
3	LVDTBEN	Enables reset of CPU speed register by LVD comparator output. 0 Disables CPU speed throttle-back. 1 Enables CPU speed throttle-back.
2:0	VM[2:0]	Sets the LVD and pump levels per the DC electrical specifications in the PSoC device data sheet, for those PSoC devices with this feature. 000b Lowest voltage setting 001b 010b . 011b . 100b . 101b 110b 111b Highest voltage setting

13.3.36 VLT_CMP

Voltage Monitor Comparators Register

Individual Register Names and Addresses:

VLT_CMP: 1,E4h

4, 2 COLUMN	7	6	5	4	3	2	1	0
Access : POR						R : 0	R : 0	R : 0
Bit Name						PUMP	LVD	PPOR

2L* Column	7	6	5	4	3	2	1	0
Access : POR					R : 0	R : 0	R : 0	R : 0
Bit Name					NoWrite	PUMP	LVD	PPOR

* The CY8C24x23A, CY8C21x34, CY8C21x23, CY7C603xx, and CYWUSB6953 PSoC devices use the two column limited functionality set of bits for this register.

1 COLUMN	7	6	5	4	3	2	1	0
Access : POR							R : 0	R : 0
Bit Name							LVD	PPOR

This register is used to read the state of internal supply voltage monitors.

Use the register tables above, in addition to the detailed register bit descriptions below, to determine which bits are reserved for some smaller PSoC devices. In the table above, note that reserved bits are grayed table cells and are not described in the bit description section. Reserved bits should always be written with a value of '0'. For additional information, refer to the “[Register Definitions](#)” on page 513 in the POR and LVD chapter.

Bit	Name	Description
3	NoWrite	This bit is only used in the CY8C24x23A, CY8C21x34, CY8C21x23, CY7C603xx, and CYWUSB6953 PSoC devices: devices with a 2.4V minimum POR. It reads the state of the Flash write voltage monitor. 0 Sufficient voltage for Flash write. 1 Insufficient voltage for Flash write.
2	PUMP	Read state of pump comparator. 0 Vdd is above trip point. 1 Vdd is below trip point.
1	LVD	Reads state of LVD comparator. 0 Vdd is above LVD trip point. 1 Vdd is below LVD trip point.
0	PPOR	Reads state of Precision POR comparator (only useful with PPOR reset disabled, with PORLEV[1:0] in VLT_CR register set to 11b). 0 Vdd is above PPOR trip voltage. 1 Vdd is below PPOR trip voltage.

13.3.37 ADCx_TR

ADC Column 0 and Column 1 Trim Register

Individual Register Names and Addresses:

ADC0_TR : 1,E5h ADC1_TR : 1,E6h

2L* Column	7	6	5	4	3	2	1	0
Access : POR	RW : 00							
Bit Name	CAPVAL_[7:0]							

* This table shows the two column limited functionality of the CY8C21x34, CY8C21x23, CY7C603xx, CYWUSB6953 PSoC devices for this register.

This register controls a combination of capacitor and current values that determine the slope of the ADC voltage ramp.

This register is only used by the CY8C21x34, CY8C21x23, CY7C603xx, and CYWUSB6953 PSoC devices. ADC0_TR is the ADC column 0 trim register and ADC1_TR is the ADC column 1 trim register. For additional information, refer to the “[Register Definitions](#)” on [page 443](#) in the Two Column Limited Analog System chapter.

Bits	Name	Description
7:0	CAPVAL_[7:0]	<p>Controls, in binary weighted segments, the capacitor trim for ADC and general analog operation. This trim has a 16-1 range. By default (0000b), all capacitors are switched into the circuit, which is the maximum capacitance.</p> <p>0 Switches that binary weighted capacitor segment into the circuit (more capacitance).</p> <p>1 Switches that binary weighted capacitor segment out of the circuit (less capacitance).</p>

13.3.38 DEC_CR2

Decimator Control Register 2

Individual Register Names and Addresses:

DEC_CR2: 1,E7h

	7	6	5	4	3	2	1	0
Access : POR	RW : 0		RW : 0		RW : 0	RW : 0		
Bit Name	Mode[1:0]		Data Out Shift[1:0]		Data Format	Decimation Rate[2:0]		

This register is used to configure the decimator before use.

This register is only for the CY8CPLC20, CY8CLED16P01, CY8C29x66, CY8C24x94, CY8CNP1xx, and CY7C64215 PSoC devices with the Type 2 Decimator. For additional information, refer to the “[Register Definitions](#)” on page 479 in the Decimator chapter.

Bits	Name	Description
7:6	Mode[1:0]	00b Backward compatibility mode for type 1 decimator blocks. 01b Incremental mode for type 2 decimator blocks. 10b Full mode for type 2 decimator blocks. 11b Reserved
5:4	Data Out Shift[1:0]	00b No shifting of bits. 01b Shift all bits to the right by one bit. 10b Shift all bits to the right by two bits. 11b Shift all bits to the right by four bits.
3	Data Format	Controls how the input data stream is interpreted by the integrator. 0 A 0/1 input is interpreted as -1/+1. 1 A 0/1 input is interpreted as 0/+1.
2:0	Decimation Rate[2:0]	000b Off (Use with an External Timer and the CY8CPLC20, CY8CLED16P01, CY8CNP1xx, or CY8C29x66 PSoC device.) 001b 32 010b 50 011b 64 100b 125 101b 128 110b 250 111b 256

13.3.39 IMO_TR

Internal Main Oscillator Trim Register

Individual Register Names and Addresses:

IMO_TR: 1,E8h

	7	6	5	4	3	2	1	0
Access : POR	W : 00							
Bit Name	Trim[7:0]							

This register is used to manually center the oscillator's output to a target frequency.

It is strongly recommended that the user not alter this register's values. The value in this register should not be changed. For additional information, refer to the "Register Definitions" on page 115 in the Internal Main Oscillator chapter.

Bit	Name	Description
7:0	Trim[7:0]	<p>The value of this register is used to trim the Internal Main Oscillator. Its value is set to the best value for the device during boot.</p> <p><i>The value of these bits should not be changed.</i></p> <p>00h Lowest frequency setting 01h 7Fh 80h Design center setting 81h FEh FFh Highest frequency setting</p>

13.3.40 ILO_TR

Internal Low Speed Oscillator Trim Register

Individual Register Names and Addresses:

ILO_TR: 1,E9h

	7	6	5	4	3	2	1	0
Access : POR			W : 0		W : 0			
Bit Name			Bias Trim[1:0]		Freq Trim[3:0]			

This register sets the adjustment for the Internal Low Speed Oscillator (ILO).

It is strongly recommended that the user not alter this register's values. The trim bits are set to factory specifications and should not be changed. In the table above, note that reserved bits are grayed table cells and are not described in the bit description section below. Reserved bits should always be written with a value of '0'. For additional information, refer to the "Register Definitions" on page 117 in the Internal Low Speed Oscillator chapter.

Bit	Name	Description
5:4	Bias Trim[1:0]	<p>The value of this register is used to trim the Internal Low Speed Oscillator. Its value is set to the device specific, best value during boot.</p> <p>The value of these bits should not be changed.</p> <p>00b Medium bias 01b Maximum bias (recommended) 10b Minimum bias 11b Intermediate Bias *</p> <p>* About 15% higher than the minimum bias.</p>
3:0	Freq Trim[3:0]	<p>The value of this register is used to trim the Internal Low Speed Oscillator. Its value is set to the device specific, best value during boot.</p> <p>The value of these bits should not be changed.</p>

13.3.41 BDG_TR

Bandgap Trim Register

Individual Register Names and Addresses:

BDG_TR: 1,EAh

4, 2 COLUMN	7	6	5	4	3	2	1	0
Access : POR		RW : 0		RW : 1				RW : 8
Bit Name		AGNDBYP		TC[1:0]				V[3:0]

2L*, 1 COLUMN	7	6	5	4	3	2	1	0
Access : POR				RW : 1				RW : 8
Bit Name				TC[1:0]				V[3:0]

* The CY8C21x23 has limited 2 column functionality. In this register, the CY8C21x23 has the same functionality as the 1 column device.

This register is used to adjust the bandgap and add an RC filter to AGND.

The CY8C27x43 PSoC device cannot read this register. Use the register tables above, in addition to the detailed register bit descriptions below, to determine which bits are reserved for some smaller PSoC devices. Note that reserved bits are grayed table cells and are not described in the bit description section. Reserved bits should always be written with a value of '0'. For additional information, refer to the ["Register Definitions"](#) on page 499 in the Internal Voltage Reference chapter.

Bit	Name	Description
6	AGNDBYP	If set, an external bypass capacitor on AGND may be connected to Port 2[4]. 0 Disable 1 Enable
5:4	TC[1:0]	The value of these bits is used to trim the temperature coefficient. Their value is set to the best value for the device during boot. The value of these bits should not be changed.
3:0	V[3:0]	The value of these bits is used to trim the bandgap reference. Their value is set to the best value for the device during boot. The value of these bits should not be changed.

13.3.42 ECO_TR

External Crystal Oscillator Trim Register

Individual Register Names and Addresses:

ECO_TR: 1,EBh

	7	6	5	4	3	2	1	0
Access : POR	W : 0							
Bit Name	PSSDC[1:0]							

This register sets the adjustment for the 32.768 kHz External Crystal Oscillator.

The value in this register should not be changed. The value is used to trim the 32.768 kHz external crystal oscillator and is set to the device specific, best value during boot. In the table above, note that reserved bits are grayed table cells and are not described in the bit description section below. Reserved bits should always be written with a value of '0'. For additional information, refer to the "Register Definitions" on page 121 in the External Crystal Oscillator (ECO) chapter.

Bit	Name	Description
7:6	PSSDC[1:0]	Sleep duty cycle. Controls the ratios (in numbers of 32.768 kHz clock periods) of "on" time versus "off" time for PORLVD, Bandgap reference, and pspump. These bits should not be changed.
		00b 1 / 128
		01b 1 / 512
		10b 1 / 32
		11b 1 / 8

13.3.43 IMO_TR1

Internal Main Oscillator Trim Register 1

Individual Register Names and Addresses:

IMO_TR1: 1,EEh

	7	6	5	4	3	2	1	0
Access : POR						RW : 0		
Bit Name						Fine Trim[2:0]		

This register is used to fine tune the IMO frequency. It is only used in the CY8C24x94 PSoC device by the IMO lock circuit for USB operation.

It is strongly recommended that the user not alter this register's values. In the table above, note that reserved bits are grayed table cells and are not described in the bit description section. Reserved bits should always be written with a value of '0'. For additional information, refer to the "Register Definitions" on page 529 in the Full-Speed USB chapter.

Bit	Name	Description
2:0	Fine Trim[2:0]	<p>The value in these bits varies the IMO frequency: approximately 7.5 kHz/step when the gain trim in the IMO_TR2 register is set correctly. When the EnableLock bit is set in the USB_CR1 register, firmware writes to this register are disabled.</p> <p>000b Lowest Frequency</p> <p>001b Approximately 7.5 kHz Faster</p> <p>...</p> <p>111b Highest Frequency</p>

13.3.44 IMO_TR2

Internal Main Oscillator Trim Register 2

Individual Register Names and Addresses:

IMO_TR2: 1,EFh

	7	6	5	4	3	2	1	0
Access : POR								
Bit Name								

This register is used to set the gain of the IMO. It is only used in the CY8C24x94 PSoC device.

It is strongly recommended that the user not alter this register's values. In the table above, note that reserved bits are grayed table cells and are not described in the bit description section. Reserved bits should always be written with a value of '0'. For additional information, refer to the "Register Definitions" on page 529 in the Full-Speed USB chapter.

Bit	Name	Description
5:0	Gain Trim[5:0]	<p>The Gain Trim value varies the gain of the IMO in the CY8C24x94 PSoC device. For oscillator locking to full-speed USB traffic, the value should be set so that each step of the IMO_TR register changes the IMO frequency by about 60 kHz.</p> <p>000000b Lowest Gain – least kHz/step 111111b Highest Gain – most kHz/step</p> <p>The Gain is reset to a non-zero value so that the initial frequency of the oscillator is high enough for the Flash pump clock.</p> <p>Simulated best setting to achieve Gain = 60 kHz/step:</p> <p>3Eh Slow Corner 2Ch Typical Corner 25h Fast Corner</p>

13.3.45 FLS_PR1

Flash Program Register 1

Individual Register Names and Addresses:

FLS_PR1: 1,FAh

	7	6	5	4	3	2	1	0
Access : POR							RW : 0	
Bit Name							Bank[1:0]	

This register is used to specify which Flash bank should be used for SROM operations.

In the table above, note that reserved bits are grayed table cells and are not described in the bit description section below. Reserved bits should always be written with a value of '0'. For additional information, refer to the [Supervisory ROM \(SROM\) chapter on page 73](#).

Bit	Name	Description
1:0	Bank[1:0]	<p>Selects the active Flash bank for supervisory operations. No affect in User mode.</p> <p>00b Flash Bank 0</p> <p>01b Flash Bank 1</p> <p>10b Flash Bank 2</p> <p>11b Flash Bank 3</p>

13.3.46 DAC_CR

Analog Mux DAC Control Register

Individual Register Names and Addresses:

DAC_CR : 1,FDh

	7	6	5	4	3	2	1	0
Access : POR	RW : 0	RW : 0			RW : 0		RW : 0	RW : 0
Bit Name	SplitMux	MuxClkGE			IRANGE		OSCMODE[1:0]	ENABLE

This register contains the control bits for the DAC current that drives the analog mux bus and for selecting the split configuration for the CY8C24x94 and CY7C64215 PSoC devices.

This register is only used by the CY8C24x94, CY8C21x34, CY7C64215, CY7C603xx, and CYWUSB6953 PSoC devices. In the table above, note that reserved bits are grayed table cells and are not described in the bit description section below. Reserved bits should always be written with a value of '0'. For additional information, refer to the ["Register Definitions"](#) on page 521.

Bits	Name	Description
7	SplitMux	Configures the analog mux bus for the CY8C24x94 and CY7C64215 PSoC devices. Left side connects to odd pins (P0[1], P5[5]) and right side connects to even pins (P0[2], P5[6]) with one exception: P0[7] is a right side pin. 0 Single analog mux bus. 1 Split analog mux bus: left side pins connect to Analog Mux Bus Left and right side pins connect to Analog Mux Bus Right.
6	MuxClkGE	Global enable connection for MUXCLK in the CY8C24x94 and CY7C64215 PSoC devices. 0 Analog mux bus clock not connected to global. 1 Connect analog mux bus clock to global GOO[6].
3	IRANGE	Sets the DAC range. Note that the value for the unit current is found in the PSoC data sheet. 0 Low range 1 High range (16 times low range)
2:1	OSCMODE[1:0]	When set, these bits enable the analog mux bus to reset to Vss whenever the comparator trip point is reached. 00b No automatic reset. 01b Reset whenever GOO[4] is high. 10b Reset whenever GOO[5] is high. 11b Reset whenever either GOO[4] or GOO[5] is high.
0	ENABLE	0 DAC function disabled (no DAC current). 1 DAC function enabled. The DAC current charges the analog mux bus. In the CY8C24x94 and CY7C64215, if the SplitMux is set high, the charging current only charges the mux bus right.

Section D: Digital System



The configurable Digital System section discusses the digital components of the PSoC device and the registers associated with those components. This section encompasses the following chapters:

- Global Digital Interconnect (GDI) on page 313
- Array Digital Interconnect (ADI) on page 325
- Row Digital Interconnect (RDI) on page 327
- Digital Blocks on page 335

Top Level Digital Architecture

The figure below displays the top level architecture of the PSoC's digital system. Each component of the figure is discussed at length in this section.

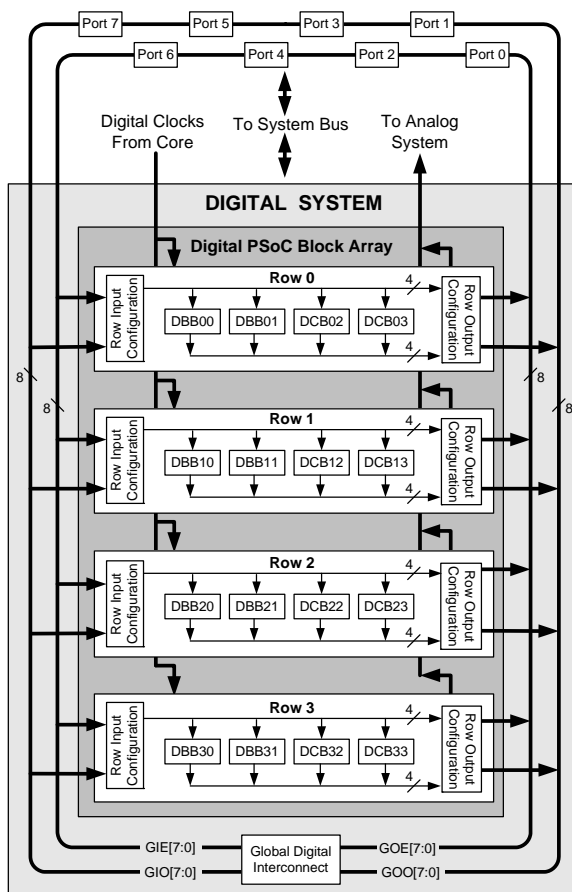

PSoC Digital System Block Diagram

Interpreting the Digital Documentation

Information in this section covers all PSoC devices with a base part number of CY8C2xxxx (except for the CY8C25122 and CY8C26xxx PSoC devices). It also applies to CY7C64215, CY7C603xx, CY8CNP1xx, and CYWUSB6953. The primary digital distinction between these devices is the number of digital rows. This can be either 1, 2, or 4 rows. The following table lists the resources available for specific device groups. While reading the digital system section, determine and keep in mind the number of digital rows that are in your device, to accurately interpret this documentation.

PSoC Device Characteristics

PSoC Part Number	Digital IO (max)	Digital Rows	Digital Blocks	Analog Inputs	Analog Outputs	Analog Columns	Analog Blocks
CY8C29x66 CY8CPLC20 CY8CLED16P01	64	4	16	12	4	4	12
CY8C27x43	44	2	8	12	4	4	12
CY8C24x94	50	1	4	48	2	2	6
CY8C24x23	24	1	4	12	2	2	6
CY8C24x23A	24	1	4	12	2	2	6
CY8C22x13	16	1	4	10	1	1	3
CY8C21x34	28	1	4	28	0	2	4*
CY8C21x23	16	1	4	8	0	2	4*
CY7C64215	50	1	4	48	2	2	6
CY7C603xx	28	1	4	28	0	2	4*
CYWUSB6953	28	1	4	28	0	2	4*
CY8CNP1xx	33	4	16	12	4	4	12

* Limited analog functionality.

Digital Register Summary

The table below lists all the PSoC registers for the digital system in address order (Add. column) within their system resource configuration. The bits that are grayed out are reserved bits. If these bits are written, they should always be written with a value of '0'. The naming conventions for the digital row registers and the digital block registers are detailed in their respective table title rows.

Note that all PSoC devices with a base part number of CY8C2xxxx (except for the CY8C25122 and CY8C26xxx PSoC devices), fall into one of the following categories with respect to their digital PSoC rows: 4 row device, 2 row device, or 1 row device. It also applies to CY7C64215, CY7C603xx, and CYWUSB6953. The “PSoC Digital System Block Diagram” at the beginning of this section illustrates this.

In the table below, the third column from the left titled “Digital Rows” indicates which of the three PSoC device categories the register falls into. To determine the number of digital rows in your PSoC device, refer to the table titled “PSoC Device Characteristics” on page 307.

Summary Table of the Digital Registers

Add.	Name	Digital Rows	Bit 7	Bit 6	Bit 5	Bit 4	Bit 3	Bit 2	Bit 1	Bit 0	Access		
GLOBAL DIGITAL INTERCONNECT (GDI) REGISTERS (page 323)													
1,D0h	GDI_O_IN	4, 3, 2, 1	GIONOUT7	GIONOUT6	GIONOUT5	GIONOUT4	GIONOUT3	GIONOUT2	GIONOUT1	GIONOUT0	RW : 00		
1,D1h	GDI_E_IN	4, 3, 2, 1	GIENOUT7	GIENOUT6	GIENOUT5	GIENOUT4	GIENOUT3	GIENOUT2	GIENOUT1	GIENOUT0	RW : 00		
1,D2h	GDI_O_OU	4, 3, 2, 1	GOOUTIN7	GOOUTIN6	GOOUTIN5	GOOUTIN4	GOOUTIN3	GOOUTIN2	GOOUTIN1	GOOUTIN0	RW : 00		
1,D3h	GDI_E_OU	4, 3, 2, 1	GOEUTIN7	GOEUTIN6	GOEUTIN5	GOEUTIN4	GOEUTIN3	GOEUTIN2	GOEUTIN1	GOEUTIN0	RW : 00		
DIGITAL ROW REGISTERS (page 329)													
x,B0h	RDI0RI	4, 3, 2, 1	RI3[1:0]		RI2[1:0]		RI1[1:0]		RI0[1:0]		RW : 00		
x,B1h	RDI0SYN	4, 3, 2, 1					RI3SYN	RI2SYN	RI1SYN	RI0SYN	RW : 00		
x,B2h	RDI0IS	4, 3, 2, 1					BCSEL[1:0]		IS3	IS2	IS1	IS0	RW : 00
x,B3h	RDI0LT0	4, 3, 2, 1	LUT1[3:0]				LUT0[3:0]				RW : 00		
x,B4h	RDI0LT1	4, 3, 2, 1	LUT3[3:0]				LUT2[3:0]				RW : 00		
x,B5h	RDI0RO0	4, 3, 2, 1	GOO5EN	GOO1EN	GOE5EN	GOE1EN	GOO4EN	GOO0EN	GOE4EN	GOE0EN	RW : 00		
x,B6h	RDI0RO1	4, 3, 2, 1	GOO7EN	GOO3EN	GOE7EN	GOE3EN	GOO6EN	GOO2EN	GOE6EN	GOE2EN	RW : 00		
x,B8h	RDI1RI	4, 3, 2	RI3[1:0]		RI2[1:0]		RI1[1:0]		RI0[1:0]		RW : 00		
x,B9h	RDI1SYN	4, 3, 2					RI3SYN	RI2SYN	RI1SYN	RI0SYN	RW : 00		
x,BAh	RDI1IS	4, 3, 2					BCSEL[1:0]		IS3	IS2	IS1	IS0	RW : 00
x,BBh	RDI1LT0	4, 3, 2	LUT1[3:0]				LUT0[3:0]				RW : 00		
x,BCh	RDI1LT1	4, 3, 2	LUT3[3:0]				LUT2[3:0]				RW : 00		
x,BDh	RDI1RO0	4, 3, 2	GOO5EN	GOO1EN	GOE5EN	GOE1EN	GOO4EN	GOO0EN	GOE4EN	GOE0EN	RW : 00		
x,BEh	RDI1RO1	4, 3, 2	GOO7EN	GOO3EN	GOE7EN	GOE3EN	GOO6EN	GOO2EN	GOE6EN	GOE2EN	RW : 00		
x,C0h	RDI2RI	4, 3	RI3[1:0]		RI2[1:0]		RI1[1:0]		RI0[1:0]		RW : 00		
x,C1h	RDI2SYN	4, 3					RI3SYN	RI2SYN	RI1SYN	RI0SYN	RW : 00		
x,C2h	RDI2IS	4, 3					BCSEL[1:0]		IS3	IS2	IS1	IS0	RW : 00
x,C3h	RDI2LT0	4, 3	LUT1[3:0]				LUT0[3:0]				RW : 00		
x,C4h	RDI2LT1	4, 3	LUT3[3:0]				LUT2[3:0]				RW : 00		
x,C5h	RDI2RO0	4, 3	GOO5EN	GOO1EN	GOE5EN	GOE1EN	GOO4EN	GOO0EN	GOE4EN	GOE0EN	RW : 00		
x,C6h	RDI2RO1	4, 3	GOO7EN	GOO3EN	GOE7EN	GOE3EN	GOO6EN	GOO2EN	GOE6EN	GOE2EN	RW : 00		
x,C8h	RDI3RI	4	RI3[1:0]		RI2[1:0]		RI1[1:0]		RI0[1:0]		RW : 00		
x,C9h	RDI3SYN	4					RI3SYN	RI2SYN	RI1SYN	RI0SYN	RW : 00		
x,CAh	RDI3IS	4					BCSEL[1:0]		IS3	IS2	IS1	IS0	RW : 00
x,CBh	RDI3LT0	4	LUT1[3:0]				LUT0[3:0]				RW : 00		
x,CCh	RDI3LT1	4	LUT3[3:0]				LUT2[3:0]				RW : 00		
x,CDh	RDI3RO0	4	GOO5EN	GOO1EN	GOE5EN	GOE1EN	GOO4EN	GOO0EN	GOE4EN	GOE0EN	RW : 00		
x,CEh	RDI3RO1	4	GOO7EN	GOO3EN	GOE7EN	GOE3EN	GOO6EN	GOO2EN	GOE6EN	GOE2EN	RW : 00		

Summary Table of the Digital Registers (continued)

Addr.	Name	Digital Rows	Bit 7	Bit 6	Bit 5	Bit 4	Bit 3	Bit 2	Bit 1	Bit 0	Access	
DIGITAL BLOCK REGISTERS (page 345)												
Digital Block Data and Control Registers (page 345)												
0,20h	DBB00DR0	4, 3, 2, 1	Data[7:0]									# : 00
0,21h	DBB00DR1	4, 3, 2, 1	Data[7:0]									W : 00
0,22h	DBB00DR2	4, 3, 2, 1	Data[7:0]									# : 00
0,23h	DBB00CR0	4, 3, 2, 1	Function control/status bits for selected function[6:0]								Enable	# : 00
1,20h	DBB00FN	4, 3, 2, 1	Data Invert	BCEN	End Single	Mode[1:0]		Function[2:0]			RW : 00	
1,21h	DBB00IN	4, 3, 2, 1	Data Input[3:0]				Clock Input[3:0]					RW : 00
1,22h	DBB00OU	4, 3, 2, 1	AUXCLK		AUXEN	AUX IO Select[1:0]		OUTEN	Output Select[1:0]		RW : 00	
0,24h	DBB01DR0	4, 3, 2, 1	Data[7:0]									# : 00
0,25h	DBB01DR1	4, 3, 2, 1	Data[7:0]									W : 00
0,26h	DBB01DR2	4, 3, 2, 1	Data[7:0]									# : 00
0,27h	DBB01CR0	4, 3, 2, 1	Function control/status bits for selected function[6:0]								Enable	# : 00
1,24h	DBB01FN	4, 3, 2, 1	Data Invert	BCEN	End Single	Mode[1:0]		Function[2:0]			RW : 00	
1,25h	DBB01IN	4, 3, 2, 1	Data Input[3:0]				Clock Input[3:0]					RW : 00
1,26h	DBB01OU	4, 3, 2, 1	AUXCLK		AUXEN	AUX IO Select[1:0]		OUTEN	Output Select[1:0]		RW : 00	
0,28h	DCB02DR0	4, 3, 2, 1	Data[7:0]									# : 00
0,29h	DCB02DR1	4, 3, 2, 1	Data[7:0]									W : 00
0,2Ah	DCB02DR2	4, 3, 2, 1	Data[7:0]									# : 00
0,2Bh	DCB02CR0	4, 3, 2, 1	Function control/status bits for selected function[6:0]								Enable	# : 00
1,28h	DCB02FN	4, 3, 2, 1	Data Invert	BCEN	End Single	Mode[1:0]		Function[2:0]			RW : 00	
1,29h	DCB02IN	4, 3, 2, 1	Data Input[3:0]				Clock Input[3:0]					RW : 00
1,2Ah	DCB02OU	4, 3, 2, 1	AUXCLK		AUXEN	AUX IO Select[1:0]		OUTEN	Output Select[1:0]		RW : 00	
0,2Ch	DCB03DR0	4, 3, 2, 1	Data[7:0]									# : 00
0,2Dh	DCB03DR1	4, 3, 2, 1	Data[7:0]									W : 00
0,2Eh	DCB03DR2	4, 3, 2, 1	Data[7:0]									# : 00
0,2Fh	DCB03CR0	4, 3, 2, 1	Function control/status bits for selected function[6:0]								Enable	# : 00
1,2Ch	DCB03FN	4, 3, 2, 1	Data Invert	BCEN	End Single	Mode[1:0]		Function[2:0]			RW : 00	
1,2Dh	DCB03IN	4, 3, 2, 1	Data Input[3:0]				Clock Input[3:0]					RW : 00
1,2Eh	DCB03OU	4, 3, 2, 1	AUXCLK		AUXEN	AUX IO Select[1:0]		OUTEN	Output Select[1:0]		RW : 00	
0,30h	DBB10DR0	4, 3, 2	Data[7:0]									# : 00
0,31h	DBB10DR1	4, 3, 2	Data[7:0]									W : 00
0,32h	DBB10DR2	4, 3, 2	Data[7:0]									# : 00
0,33h	DBB10CR0	4, 3, 2	Function control/status bits for selected function[7:1]								Enable	# : 00
1,30h	DBB10FN	4, 3, 2	Data Invert	BCEN	End Single	Mode[1:0]		Function[2:0]			RW : 00	
1,31h	DBB10IN	4, 3, 2	Data Input[3:0]				Clock Input[3:0]					RW : 00
1,32h	DBB10OU	4, 3, 2	AUXCLK		AUXEN	AUX IO Select[1:0]		OUTEN	Output Select[1:0]		RW : 00	
0,34h	DBB11DR0	4, 3, 2	Data[7:0]									# : 00
0,35h	DBB11DR1	4, 3, 2	Data[7:0]									W : 00
0,36h	DBB11DR2	4, 3, 2	Data[7:0]									# : 00
0,37h	DBB11CR0	4, 3, 2	Function control/status bits for selected function[7:1]								Enable	# : 00
1,34h	DBB11FN	4, 3, 2	Data Invert	BCEN	End Single	Mode[1:0]		Function[2:0]			RW : 00	
1,35h	DBB11IN	4, 3, 2	Data Input[3:0]				Clock Input[3:0]					RW : 00
1,36h	DBB11OU	4, 3, 2	AUXCLK		AUXEN	AUX IO Select[1:0]		OUTEN	Output Select[1:0]		RW : 00	
0,38h	DCB12DR0	4, 3, 2	Data[7:0]									# : 00
0,39h	DCB12DR1	4, 3, 2	Data[7:0]									W : 00
0,3Ah	DCB12DR2	4, 3, 2	Data[7:0]									# : 00
0,3Bh	DCB12CR0	4, 3, 2	Function control/status bits for selected function[7:1]								Enable	# : 00
1,38h	DCB12FN	4, 3, 2	Data Invert	BCEN	End Single	Mode[1:0]		Function[2:0]			RW : 00	
1,39h	DCB12IN	4, 3, 2	Data Input[3:0]				Clock Input[3:0]					RW : 00

Summary Table of the Digital Registers (continued)

Addr.	Name	Digital Rows	Bit 7	Bit 6	Bit 5	Bit 4	Bit 3	Bit 2	Bit 1	Bit 0	Access	
1,3Ah	DCB12OU	4, 3, 2	AUXCLK		AUXEN	AUX IO Select[1:0]		OUTEN	Output Select[1:0]		RW : 00	
0,3Ch	DCB13DR0	4, 3, 2	Data[7:0]									# : 00
0,3Dh	DCB13DR1	4, 3, 2	Data[7:0]									W : 00
0,3Eh	DCB13DR2	4, 3, 2	Data[7:0]									# : 00
0,3Fh	DCB13CR0	4, 3, 2	Function control/status bits for selected function[7:1]								Enable	# : 00
1,3Ch	DCB13FN	4, 3, 2	Data Invert	BCEN	End Single	Mode[1:0]		Function[2:0]			RW : 00	
1,3Dh	DCB13IN	4, 3, 2	Data Input[3:0]				Clock Input[3:0]				RW : 00	
1,3Eh	DCB13OU	4, 3, 2	AUXCLK		AUXEN	AUX IO Select[1:0]		OUTEN	Output Select[1:0]		RW : 00	
0,40h	DBB20DR0	4, 3	Data[7:0]									# : 00
0,41h	DBB20DR1	4, 3	Data[7:0]									W : 00
0,42h	DBB20DR2	4, 3	Data[7:0]									# : 00
0,43h	DBB20CR0	4, 3	Function control/status bits for selected function[7:1]								Enable	# : 00
1,40h	DBB20FN	4, 3	Data Invert	BCEN	End Single	Mode[1:0]		Function[2:0]			RW : 00	
1,41h	DBB20IN	4, 3	Data Input[3:0]				Clock Input[3:0]				RW : 00	
1,42h	DBB20OU	4, 3	AUXCLK		AUXEN	AUX IO Select[1:0]		OUTEN	Output Select[1:0]		RW : 00	
0,44h	DBB21DR0	4, 3	Data[7:0]									# : 00
0,45h	DBB21DR1	4, 3	Data[7:0]									W : 00
0,46h	DBB21DR2	4, 3	Data[7:0]									# : 00
0,47h	DBB21CR0	4, 3	Function control/status bits for selected function[7:1]								Enable	# : 00
1,44h	DBB21FN	4, 3	Data Invert	BCEN	End Single	Mode[1:0]		Function[2:0]			RW : 00	
1,45h	DBB21IN	4, 3	Data Input[3:0]				Clock Input[3:0]				RW : 00	
1,46h	DBB21OU	4, 3	AUXCLK		AUXEN	AUX IO Select[1:0]		OUTEN	Output Select[1:0]		RW : 00	
0,48h	DCB22DR0	4, 3	Data[7:0]									# : 00
0,49h	DCB22DR1	4, 3	Data[7:0]									W : 00
0,4Ah	DCB22DR2	4, 3	Data[7:0]									# : 00
0,4Bh	DCB22CR0	4, 3	Function control/status bits for selected function[7:1]								Enable	# : 00
1,48h	DCB22FN	4, 3	Data Invert	BCEN	End Single	Mode[1:0]		Function[2:0]			RW : 00	
1,49h	DCB22IN	4, 3	Data Input[3:0]				Clock Input[3:0]				RW : 00	
1,4Ah	DCB22OU	4, 3	AUXCLK		AUXEN	AUX IO Select[1:0]		OUTEN	Output Select[1:0]		RW : 00	
0,4Ch	DCB23DR0	4, 3	Data[7:0]									# : 00
0,4Dh	DCB23DR1	4, 3	Data[7:0]									W : 00
0,4Eh	DCB23DR2	4, 3	Data[7:0]									# : 00
0,4Fh	DCB23CR0	4, 3	Function control/status bits for selected function[7:1]								Enable	# : 00
1,4Ch	DCB23FN	4, 3	Data Invert	BCEN	End Single	Mode[1:0]		Function[2:0]			RW : 00	
1,4Dh	DCB23IN	4, 3	Data Input[3:0]				Clock Input[3:0]				RW : 00	
1,4Eh	DCB23OU	4, 3	AUXCLK		AUXEN	AUX IO Select[1:0]		OUTEN	Output Select[1:0]		RW : 00	
0,50h	DBB30DR0	4	Data[7:0]									# : 00
0,51h	DBB30DR1	4	Data[7:0]									W : 00
0,52h	DBB30DR2	4	Data[7:0]									# : 00
0,53h	DBB30CR0	4	Function control/status bits for selected function[7:1]								Enable	# : 00
1,50h	DBB30FN	4	Data Invert	BCEN	End Single	Mode[1:0]		Function[2:0]			RW : 00	
1,51h	DBB30IN	4	Data Input[3:0]				Clock Input[3:0]				RW : 00	
1,52h	DBB30OU	4	AUXCLK		AUXEN	AUX IO Select[1:0]		OUTEN	Output Select[1:0]		RW : 00	
0,54h	DBB31DR0	4	Data[7:0]									# : 00
0,55h	DBB31DR1	4	Data[7:0]									W : 00
0,56h	DBB31DR2	4	Data[7:0]									# : 00
0,57h	DBB31CR0	4	Function control/status bits for selected function[7:1]								Enable	# : 00
1,54h	DBB31FN	4	Data Invert	BCEN	End Single	Mode[1:0]		Function[2:0]			RW : 00	
1,55h	DBB31IN	4	Data Input[3:0]				Clock Input[3:0]				RW : 00	
1,56h	DBB31OU	4	AUXCLK		AUXEN	AUX IO Select[1:0]		OUTEN	Output Select[1:0]		RW : 00	

Summary Table of the Digital Registers (continued)

Add.	Name	Digital Rows	Bit 7	Bit 6	Bit 5	Bit 4	Bit 3	Bit 2	Bit 1	Bit 0	Access		
0,58h	DCB32DR0	4	Data[7:0]									# : 00	
0,59h	DCB32DR1	4	Data[7:0]									W : 00	
0,5Ah	DCB32DR2	4	Data[7:0]									# : 00	
0,5Bh	DCB32CR0	4	Function control/status bits for selected function[7:1]									Enable	# : 00
1,58h	DCB32FN	4	Data Invert	BCEN	End Single	Mode[1:0]		Function[2:0]			RW : 00		
1,59h	DCB32IN	4	Data Input[3:0]				Clock Input[3:0]				RW : 00		
1,5Ah	DCB32OU	4	AUXCLK		AUXEN	AUX IO Select[1:0]		OUTEN	Output Select[1:0]		RW : 00		
0,5Ch	DCB33DR0	4	Data[7:0]									# : 00	
0,5Dh	DCB33DR1	4	Data[7:0]									W : 00	
0,5Eh	DCB33DR2	4	Data[7:0]									# : 00	
0,5Fh	DCB33CR0	4	Function control/status bits for selected function[7:1]									Enable	# : 00
1,5Ch	DCB33FN	4	Data Invert	BCEN	End Single	Mode[1:0]		Function[2:0]			RW : 00		
1,5Dh	DCB33IN	4	Data Input[3:0]				Clock Input[3:0]				RW : 00		
1,5Eh	DCB33OU	4	AUXCLK		AUXEN	AUX IO Select[1:0]		OUTEN	Output Select[1:0]		RW : 00		
Digital Block Interrupt Mask Registers (page 351)													
0,DFh	INT_MSK2	4, 3	DCB33	DCB32	DBB31	DBB30	DCB23	DCB22	DBB21	DBB20	RW : 00		
0,E1h	INT_MSK1	4, 3, 2	DCB13	DCB12	DBB11	DBB10	DCB03	DCB02	DBB01	DBB00	RW : 00		
		1					DCB03	DCB02	DBB01	DBB00			

LEGEND

- x An 'x' before the comma in the address field indicates that this register can be read or written to no matter what bank is used. R: Read register or bit(s).
- # Access is bit specific. Refer to the [Register Details chapter on page 147](#) for additional information.
- R Read register or bit(s).
- W Write register or bit(s).

14. Global Digital Interconnect (GDI)



This chapter discusses the Global Digital Interconnect (GDI) and its associated registers. All PSoC CY8C2xxxx devices (except for the CY8C25122 and CY8C26xxx PSoC devices) have the exact same global digital interconnect options, varying only in the number of 8-bit ports connected to the globals. For a complete table of the GDI registers, refer to the “[Summary Table of the Digital Registers](#)” on page 308. For a quick reference of all PSoC registers in address order, refer to the [Register Details](#) chapter on page 147.

14.1 Architectural Description

Global Digital Interconnect (GDI) consists of four 8-bit buses (refer to the figures that follow). Two of the buses are input buses, which allow signals to pass from the device pins to the core of the PSoC device. These buses are called Global Input Odd (GIO[7:0]) and Global Input Even (GIE[7:0]). The other two buses are output buses that allow signals to pass from the core of the PSoC device to the device pins. They are called Global Output Odd (GOO[7:0]) and Global Output Even (GOE[7:0]). The word “odd” or “even” in the bus name indicates which device ports the bus connects to. Buses with odd in their name connect to all odd numbered ports. Buses with even in their name connect to all even numbered ports.

There are two ends to the global digital interconnect core signals and port pins. An end may be configured as a source or a destination. For example, a GPIO pin may be configured to drive a global input or receive a global output and drive it to the package pin. Globals cannot “loop through” a GPIO. Currently, there are two types of core signals connected to the global buses. The digital blocks, which may be a source or a destination for a global *net*, and system clocks, which may only drive global nets.

Many of the digital clocks may also be driven on to the global bus to allow the clocks to route directly to IO pins. This is shown in the global interconnect block diagrams on the following pages. For more information on this feature, see the [Digital Clocks](#) chapter on page 459.

Each global input and global output has a *keeper* on it. The keeper sets the value of the global to ‘1’ on system reset and holds the last driven value of the global should it become un-driven.

The primary goal, of the architectural block diagrams that follow, is to communicate the relationship between global buses (GOE, GOO, GIE, GIO) and pins. Note that any global input may be connected to its corresponding global output, using the tri-state buffers located in the corners of the figures. Also, global outputs may be shorted to global inputs using these tri-state buffers. The rectangle in the center of the figure represents the array of digital PSoC blocks.

14.1.1 8-Pin Global Interconnect

For 8-pin PSoC devices, there are two 8-bit ports. Therefore, there is one port connected to the even global buses and one port connected to the odd global buses. Table 14-1 lists the mapping between global buses and ports.

Table 14-1. 8-Pin Global Bus to Port Mapping

Global Bus	Ports
GIO[1:0], GOO[1:0]	P1
GIE[5:2], GOE[5:2]	P0

Because only one port is connected to each global input/output pair, the 8-pin PSoC device does not have the one-to-many relationship between globals and port pins that other devices have. In fact, not every global can be connected to a port pin, but they can be used for internal signal routing. For example, if GIO[1] is used to bring an input signal into a digital PSoC block, only pin P1[1] may be used. The same is true for the outputs. For example, if GOE[3] is used to carry a signal from a digital PSoC block to a port pin, only P0[3] may be used.

To determine the number of digital rows and digital blocks in your PSoC device, refer to the table titled “PSoC Device Characteristics” on page 307.

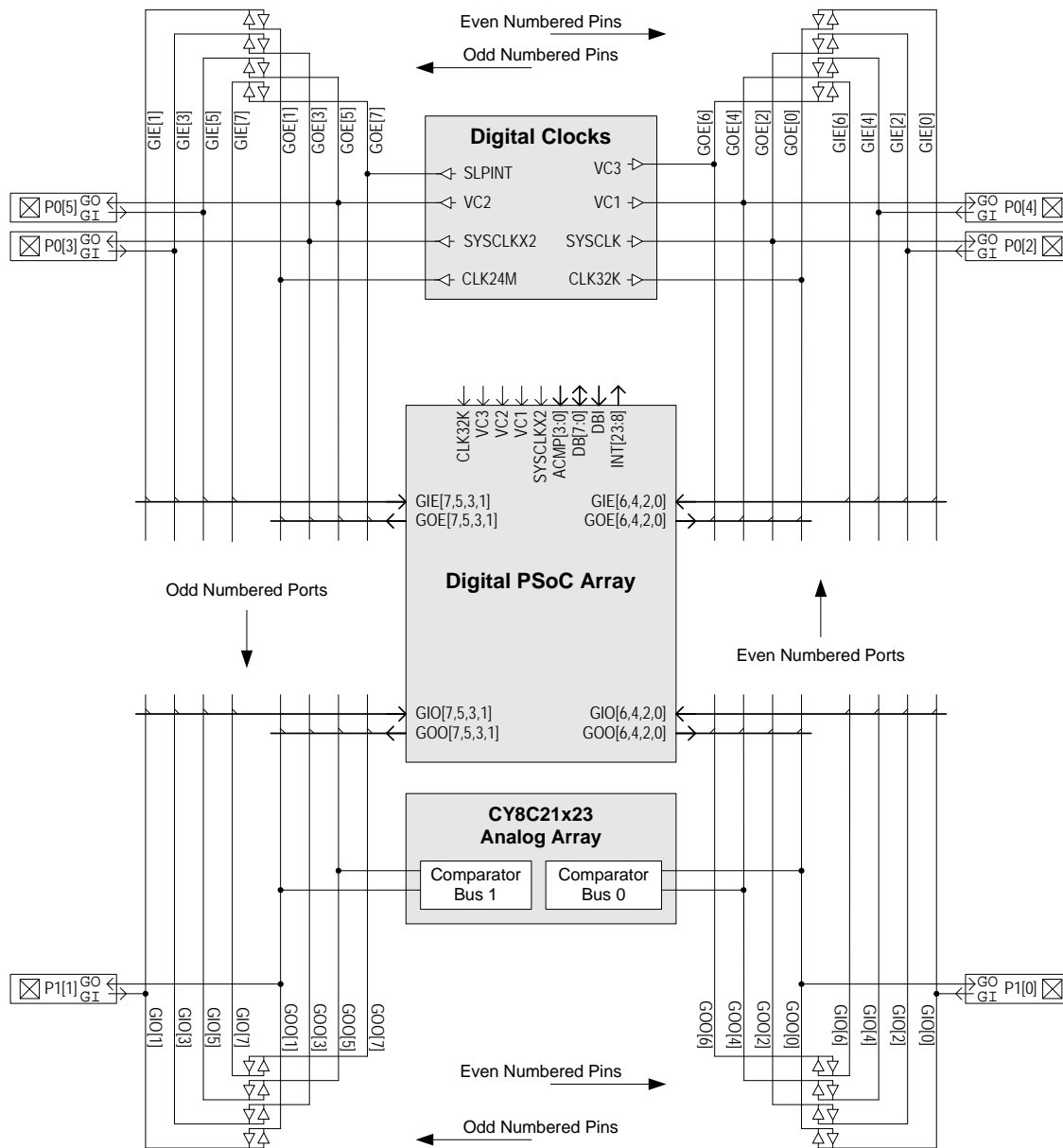

Figure 14-1. Global Interconnect Block Diagram for an 8-Pin Package

14.1.2 16-Pin Global Interconnect

For 16-pin PSoC devices, there are two 8-bit ports: one port connected to the even global buses and one port connected to the odd global buses. Table 14-2 lists the mapping between global buses and ports. Note that the 16-pin package is only available for the CY8C21x34, CY8C21x23, CY7C603xx, and CYWUSB6953 PSoC devices.

Table 14-2. 16-Pin Global Bus to Port Mapping

Global Bus	Ports
GIO[4, 2:0], GOO[4, 2:0]	P1
GIE[7:0], GOE[7:0]	P0

Because only one port is connected to each global input/output pair, the 16-pin PSoC device does not have the one-to-many relationship between globals and port pins that other devices have. For example, if GIO[1] is used to bring an input signal into a digital PSoC block, only pin P1[1] may be used. The same is true for the outputs. For example, if GOE[3] is used to carry a signal from a digital PSoC block to a port pin, only P0[3] may be used.

To determine the number of digital rows and digital blocks in your PSoC device, refer to the table titled “PSoC Device Characteristics” on page 307.

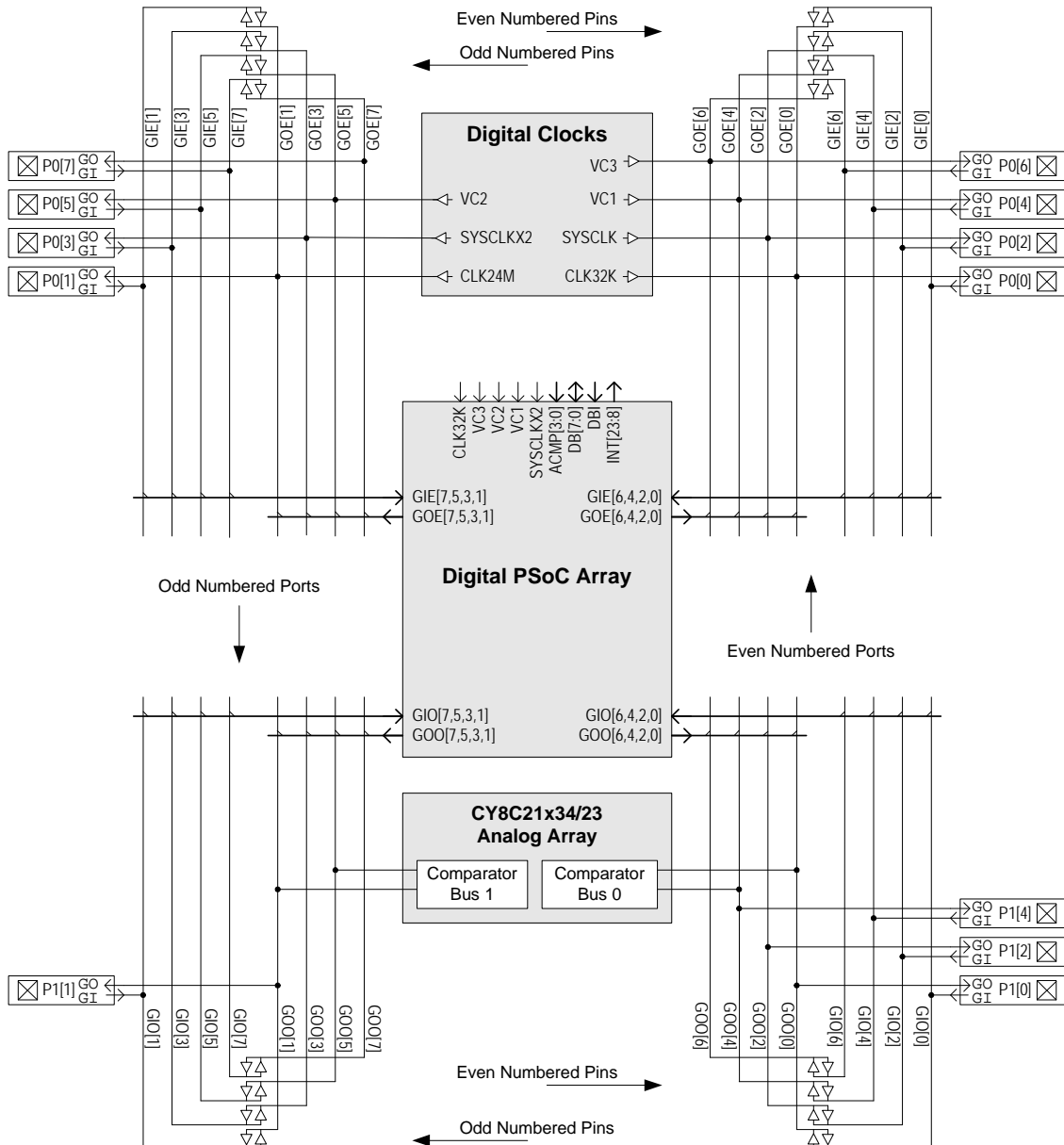

Figure 14-2. Global Interconnect Block Diagram for the CY8C21x34/23, CY7C603xx, and CYWUSB6953 16-Pin Package

14.1.3 20- to 24-Pin Global Interconnect

For 20- to 24-pin PSoC devices, there are two 8-bit ports. Therefore, there is one port connected to the even global buses and one port connected to the odd global buses. Table 14-3 lists the mapping between global buses and ports.

Table 14-3. 20- to 24-Pin Global Bus to Port Mapping

Global Bus	Ports
GIO[7:0], GOO[7:0]	P1
GIE[7:0], GOE[7:0]	P0

Because only one port is connected to each global input/output pair, the 20- to 24-pin PSoC device does not have the one-to-many relationship between globals and port pins that other devices have. For example, if GIO[1] is used to bring an input signal into a digital PSoC block, only pin P1[1] may be used. The same is true for the outputs. For example, if GOE[3] is used to carry a signal from a digital PSoC block to a port pin, only P0[3] may be used.

To determine the number of digital rows and digital blocks in your PSoC device, refer to the table titled “PSoC Device Characteristics” on page 307.

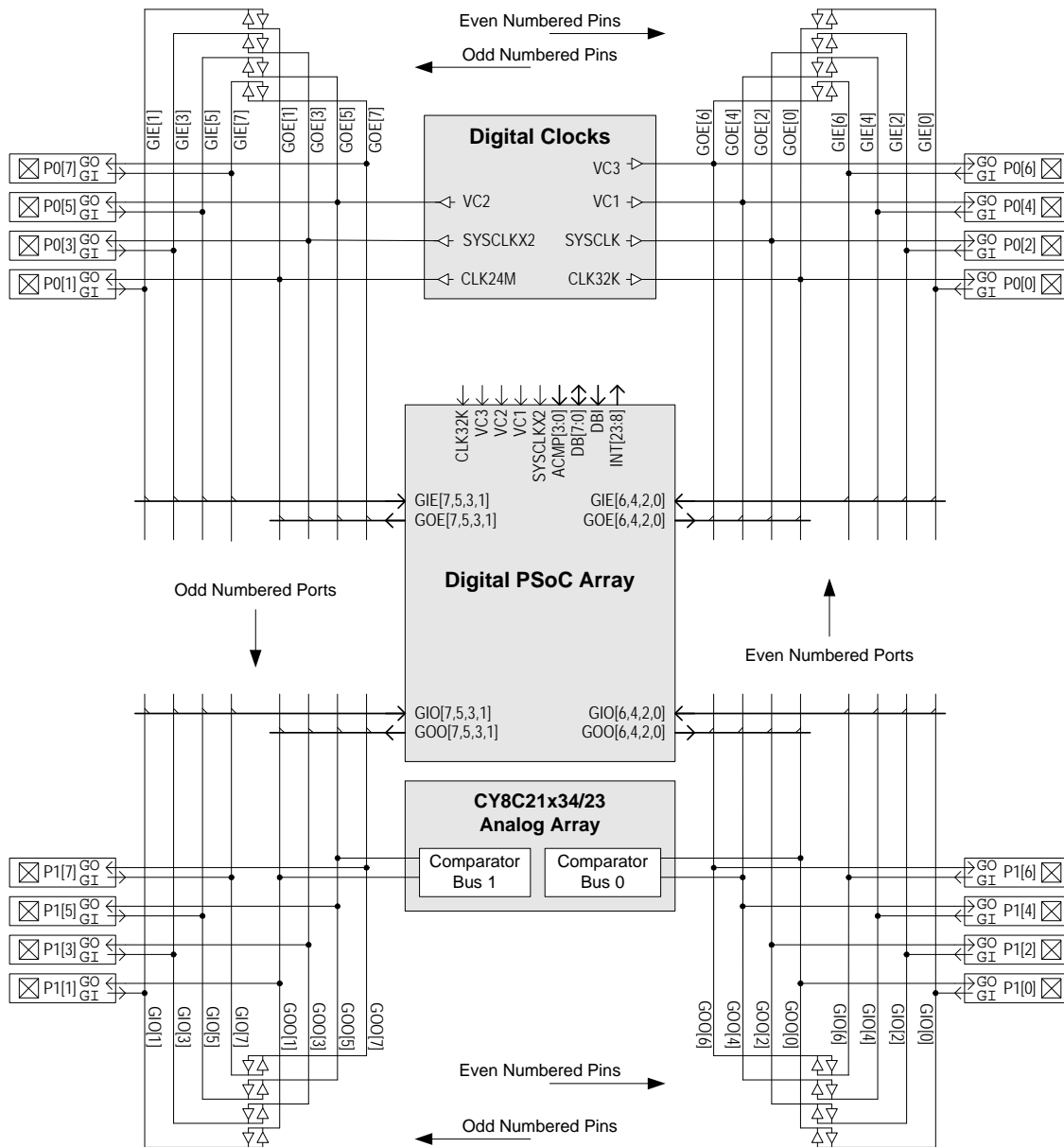

Figure 14-3. Global Interconnect Block Diagram for a 20- to 24-Pin Package

14.1.4 28- to 32-Pin Global Interconnect

For 28- to 32-pin PSoC devices (except for the CY8C21x34, CY7C603xx, and CYWUSB6953 described on the next page), there are three 8-bit ports. Therefore, there are two ports connected to the even global buses and one port connected to the odd global buses. [Table 14-4](#) lists the mapping between global buses and ports.

Table 14-4. 28- to 32-Pin Global Bus to Port Mapping

Global Bus	Ports
GIO[7:0], GOO[7:0]	P1
GIE[7:0], GOE[7:0]	P0, P2

Because up to two ports are connected to a single global bus, there is a one-to-many mapping between individual

nets in a global bus and port pins. For example, if GIE[1] is used to bring an input signal into a digital PSoC block, either pin P0[1] or P2[1] may be used. The same is true for the outputs. For example, if GOE[3] is used to carry a signal from a digital PSoC block to a port pin, either or both of the following pins may be used: P0[3] or P2[3]. Only Port 1 pins connect to the GIO/GOO globals in these 28- and 32-pin PSoC devices.

Note that the CY8C21x34, CY7C603xx, and CYWUSB6953 32-pin packages are different from other 32-pin PSoC packages and are illustrated in [Figure 14-5](#).

To determine the number of digital rows and digital blocks in your PSoC device, refer to the table titled “PSoC Device Characteristics” on page 307.

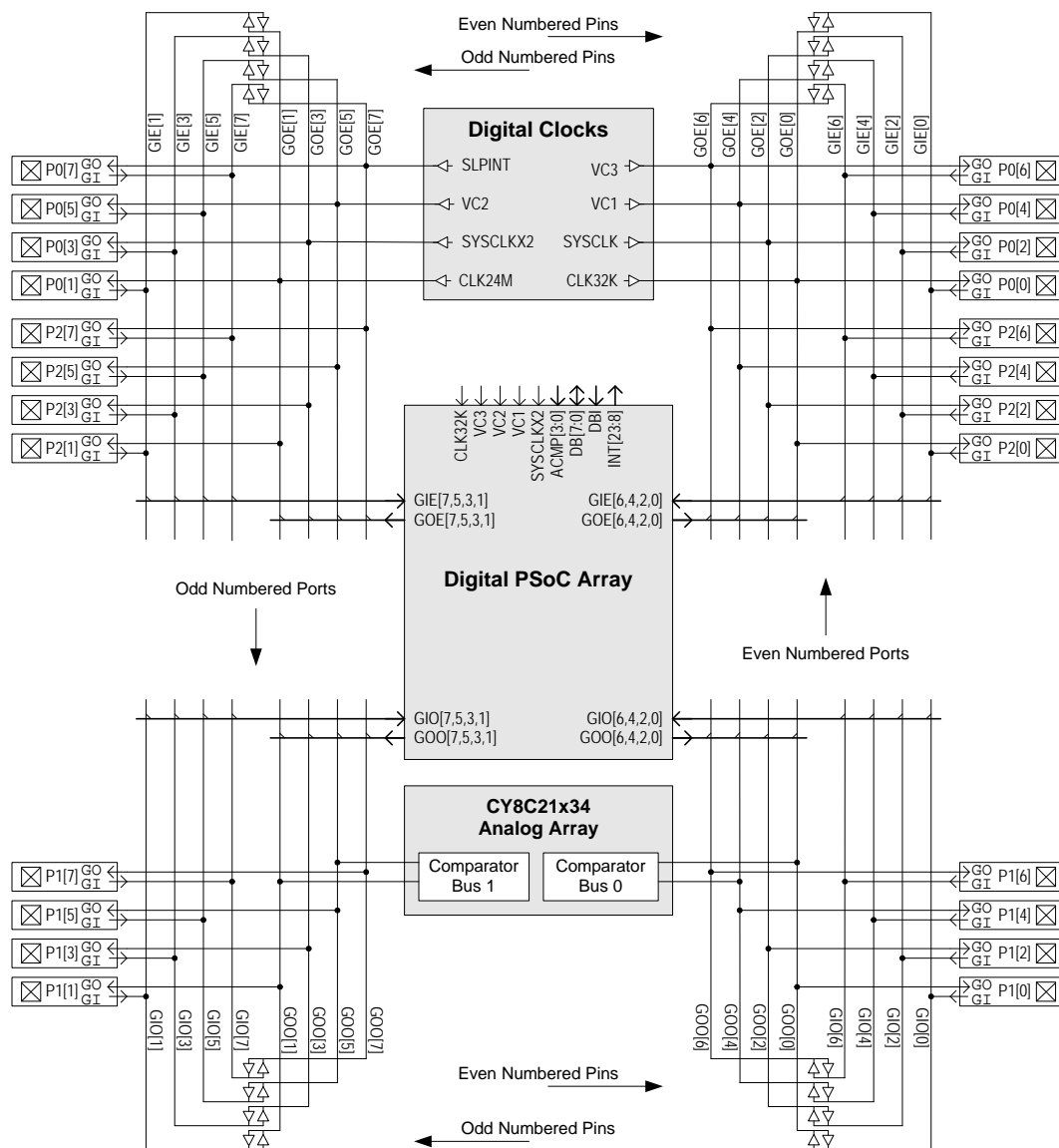

Figure 14-4. Global Interconnect Block Diagram for a 28- to 32-Pin Package

14.1.4.1 32-Pin GDI for the CY8C21x34, CY7C603xx, and CYWUSB6953

For the CY8C21x34, CY7C603xx, and CYWUSB6953 32-pin PSoC devices, there are three and a half 8-bit ports. Therefore, there are two ports connected to the even global buses and one port connected to the odd global buses. Table 14-5 lists the mapping between global buses and ports.

Table 14-5. 32-Pin Global Bus to Port Mapping for the CY8C21x34, CY7C603xx, and CYWUSB6953

Global Bus	Ports
GIO[7:0], GOO[7:0]	P1, P3
GIE[7:0], GOE[7:0]	P0, P2

Because up to two ports are connected to a single global bus, there is a one-to-many mapping between individual nets in a global bus and port pins. For example, if GIO[1] is used to bring an input signal into a digital PSoC block, either pin P1[1] or P3[1] may be used. The same is true for the outputs. For example, if GOE[3] is used to carry a signal from a digital PSoC block to a port pin, either or both of the following pins may be used: P0[3] or P2[3].

To determine the number of digital rows and digital blocks in your PSoC device, refer to the table titled “PSoC Device Characteristics” on page 307.

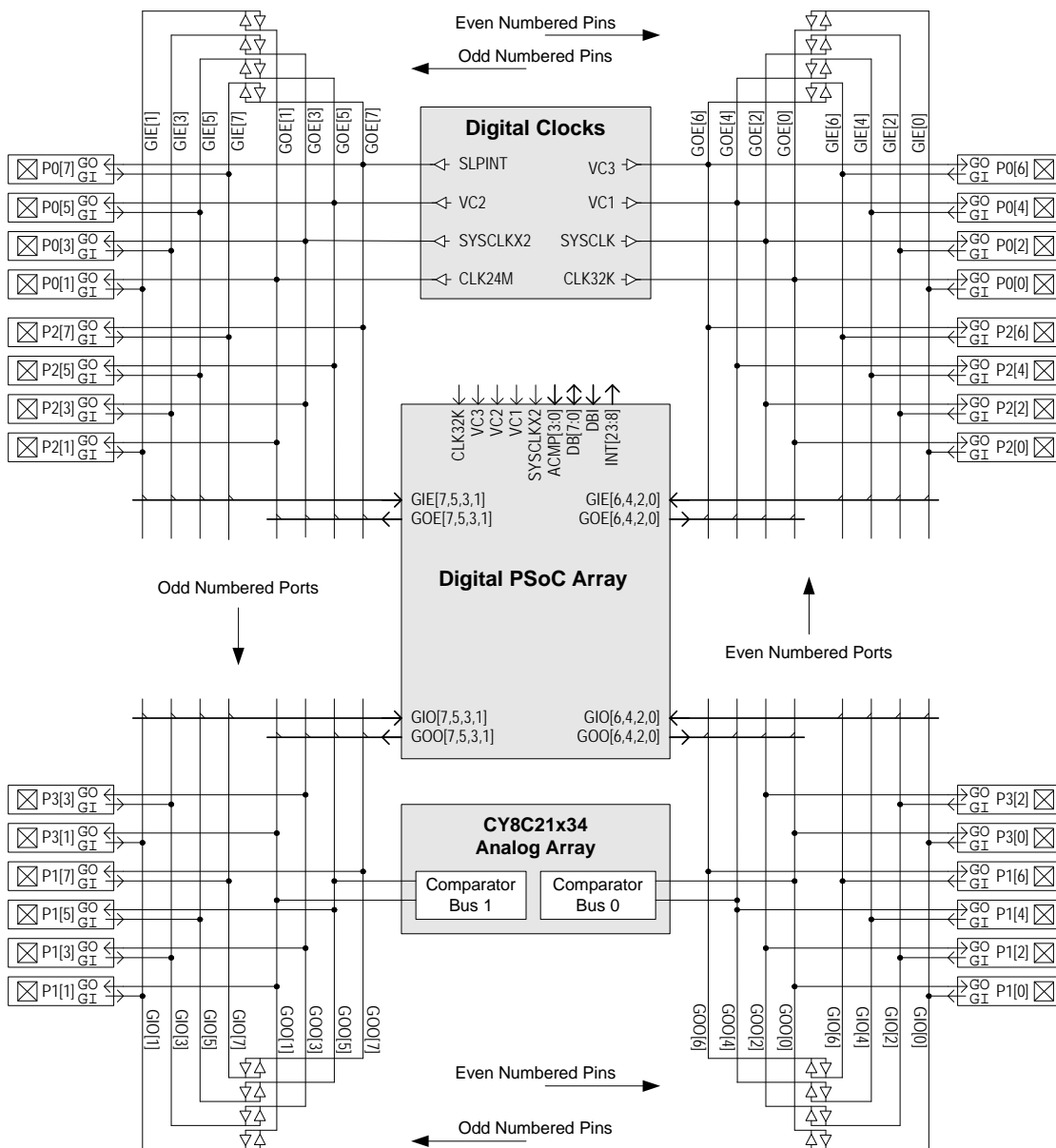

Figure 14-5. Global Interconnect Block Diagram for CY8C21x34, CY7C603xx, and CYWUSB6953 32-Pin Packages

14.1.5 44-Pin Global Interconnect

For 44-pin PSoC devices, there are five 8-bit ports. Therefore, there are up to three ports connected to the even global buses and two ports connected to the odd global buses. Table 14-6 lists the mapping between global buses and ports.

Table 14-6. 44-Pin Global Bus to Port Mapping

Global Bus	Ports
GIO[7:0], GOO[7:0]	P1, P3
GIE[7:0], GOE[7:0]	P0, P2, P4

Because several ports are connected to a single global bus, there is a one-to-many mapping between individual nets in a global bus and port pins. For example, if GIO[1] is used to bring an input signal into a digital PSoC block, either pin P1[1] or P3[1] may be used. The same is true for the outputs. For example, if GOE[3] is used to carry a signal from a digital PSoC block to a port pin, any or all of the following pins may be used: P0[3], P2[3], or P4[3].

To determine the number of digital rows and digital blocks in your PSoC device, refer to the table titled "PSoC Device Characteristics" on page 307.

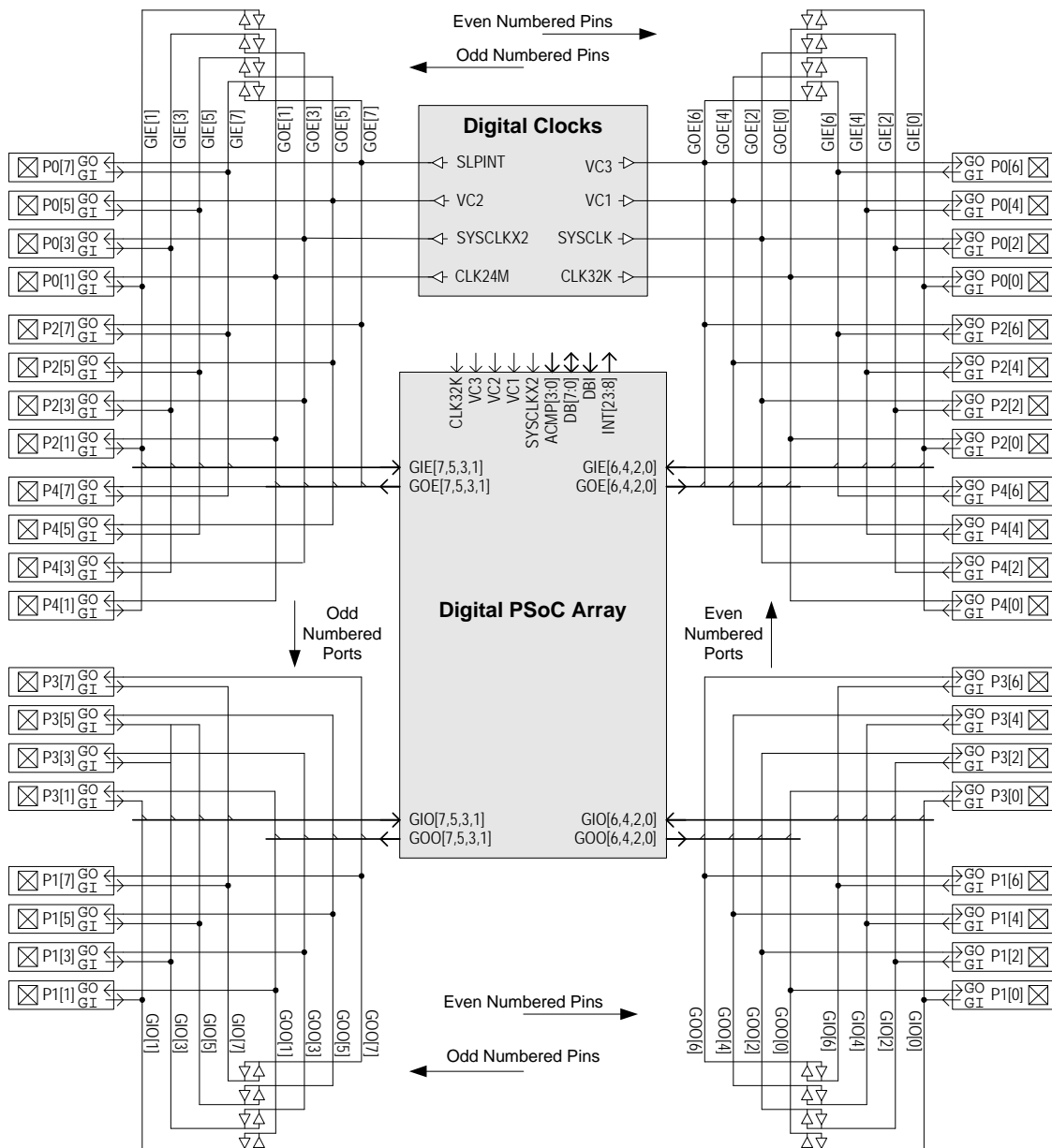

Figure 14-6. Global Interconnect Block Diagram for a 44-Pin Package

14.1.6 48-Pin Global Interconnect

For 48-pin PSoC devices, there are five and a half 8-bit ports. Therefore, there are up to three ports connected to the even global buses and up to three ports connected to the odd global buses. Table 14-7 lists the mapping between global buses and ports.

Table 14-7. 48-Pin Global Bus to Port Mapping

Global Bus	Ports
GIO[7:0], GOO[7:0]	P1, P3, P5
GIE[7:0], GOE[7:0]	P0, P2, P4

Because several ports are connected to a single global bus, there is a one-to-many mapping between individual nets in a global bus and port pins. For example, if GIO[1] is used to bring an input signal into a digital PSoC block, either pin P1[1], P3[1], or P5[1] may be used. The same is true for the outputs. For example, if GOE[3] is used to carry a signal from a digital PSoC block to a port pin, any or all of the following pins may be used: P0[3], P2[3], or P4[3].

To determine the number of digital rows and digital blocks in your PSoC device, refer to the table titled “PSoC Device Characteristics” on page 307.

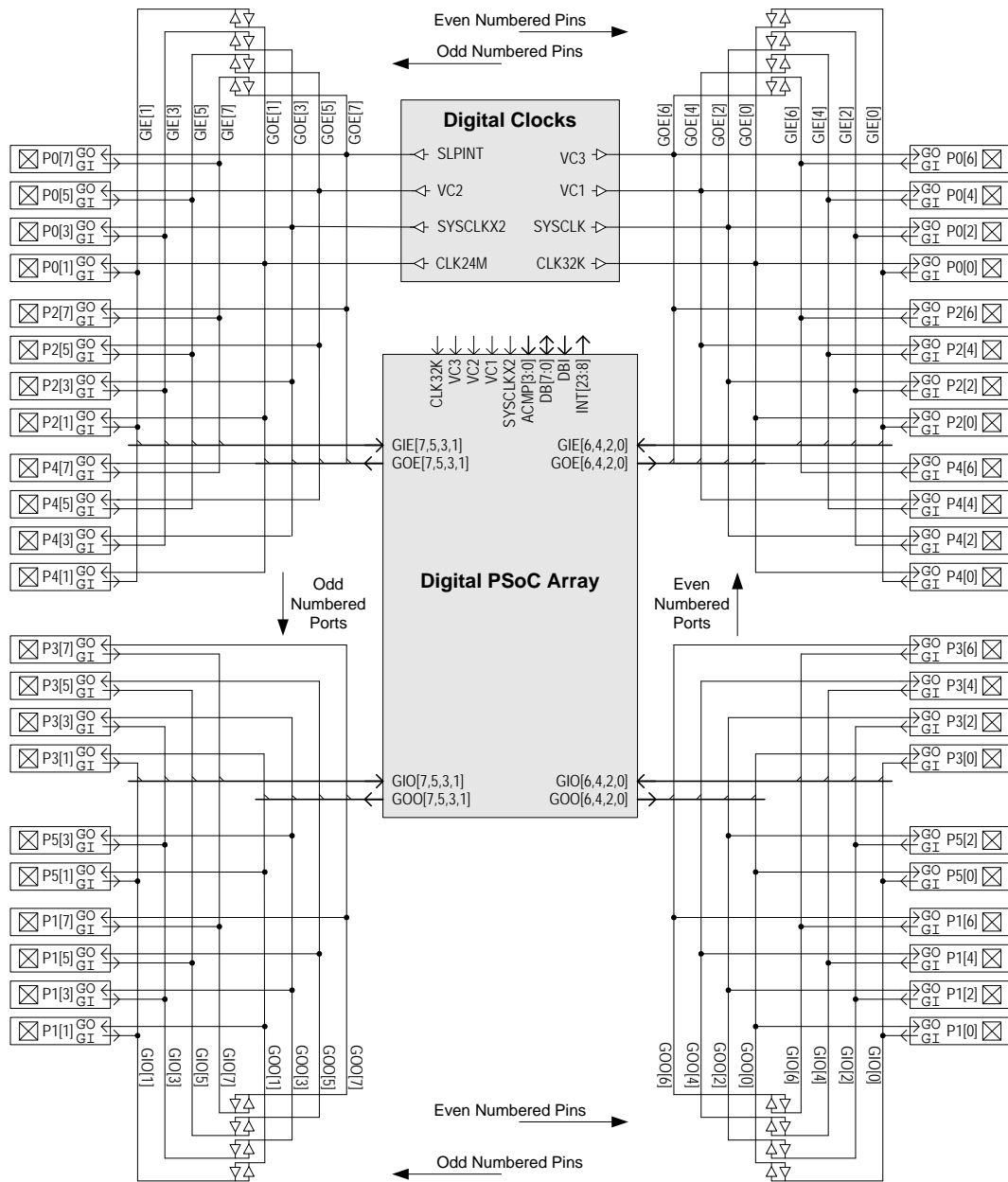

Figure 14-7. Global Interconnect Block Diagram for a 48-Pin Package

14.1.7 56-Pin Global Interconnect for the CY8C24x94 and CY7C64215

The CY8C24x94 and CY7C64215 56-pin PSoC devices have six full 8-bit ports and a partial Port 7. Therefore, there are up to three ports connected to the even global buses and up to four ports connected to the odd global buses. Table 14-7 lists the mapping between global buses and ports.

Table 14-8. 48-Pin Global Bus to Port Mapping

Global Bus	Ports
GIO[7:0], GOO[7:0]	P1, P3, P5, P7
GIE[7:0], GOE[7:0]	P0, P2, P4

Because several ports are connected to a single global bus, there is a one-to-many mapping between individual nets in a global bus and port pins. For example, if GIO[1] is used to bring an input signal into a digital PSoC block, either pin P1[1], P3[1], or P5[1] may be used. The same is true for the outputs. For example, if GOE[3] is used to carry a signal from a digital PSoC block to a port pin, any or all of the following pins may be used: P0[3], P2[3], or P4[3].

To determine the number of digital rows and digital blocks in your PSoC device, refer to the table titled “PSoC Device Characteristics” on page 307.

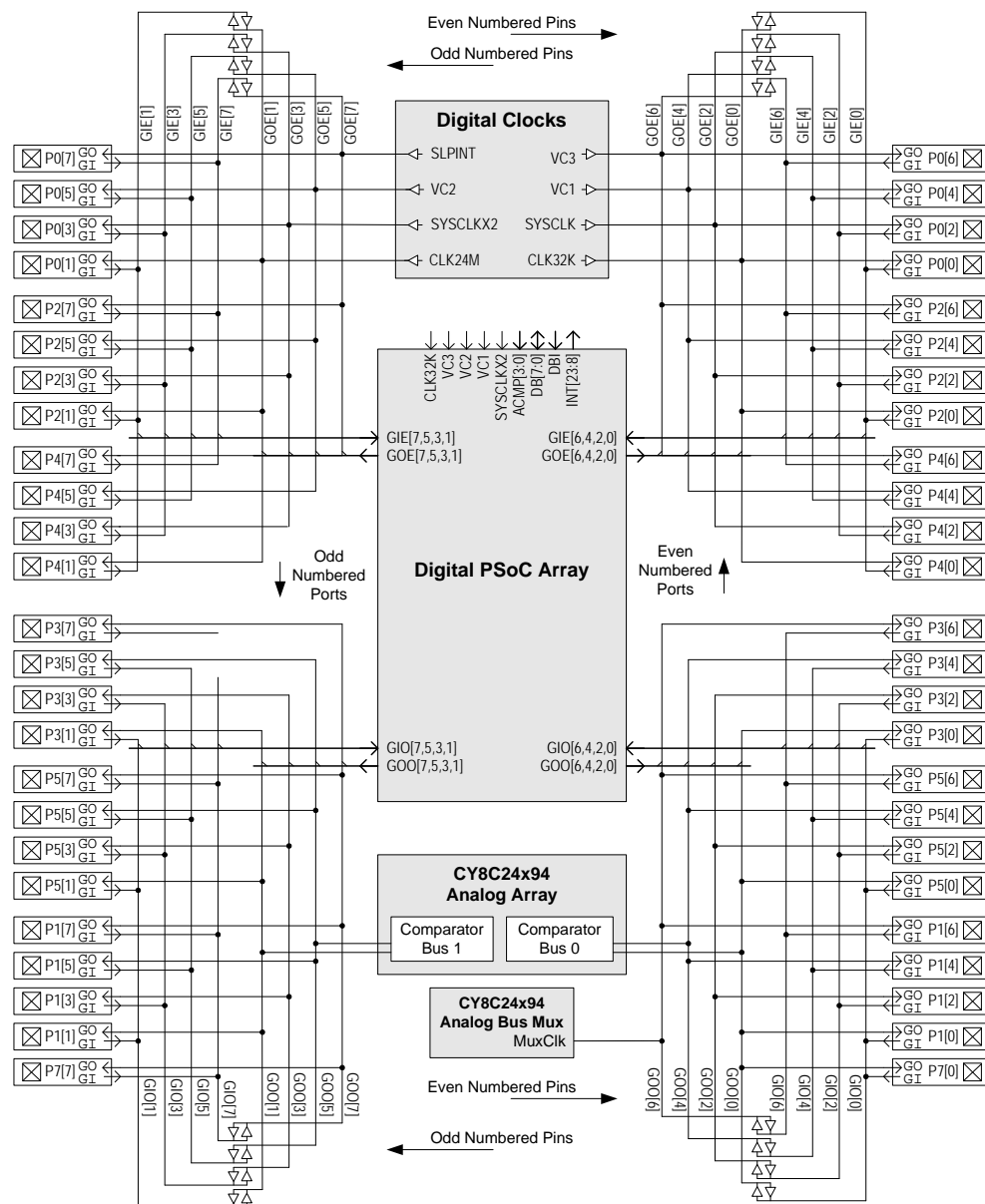

Figure 14-8. Global Interconnect Block Diagram for the CY8C24x94 and CY7C64215 56-Pin Package

14.1.8 100-Pin Global Interconnect

For 100-pin PSoC devices, there are eight 8-bit ports. Therefore, there are four ports connected to the even global buses and four ports connected to the odd global buses. Table 14-9 lists the mapping between global buses and ports.

Table 14-9. 100-Pin Global Bus to Port Mapping

Global Bus	Ports
GIO[7:0], GOO[7:0]	P1, P3, P5, P7
GIE[7:0], GOE[7:0]	P0, P2, P4, P6

Because several ports are connected to a single global bus, there is a one-to-many mapping between individual nets in a global bus and port pins. For example, if GIO[1] is used to bring an input signal into a digital PSoC block, either pin P1[1], P3[1], P5[1], or P7[1] may be used. The same is true for the outputs. For example, if GOE[3] is used to carry a signal from a digital PSoC block to a port pin, any or all of the following pins may be used: P0[3], P2[3], P4[3], or P6[3].

To determine the number of digital rows and digital blocks in your PSoC device, refer to the table titled “PSoC Device Characteristics” on page 307.

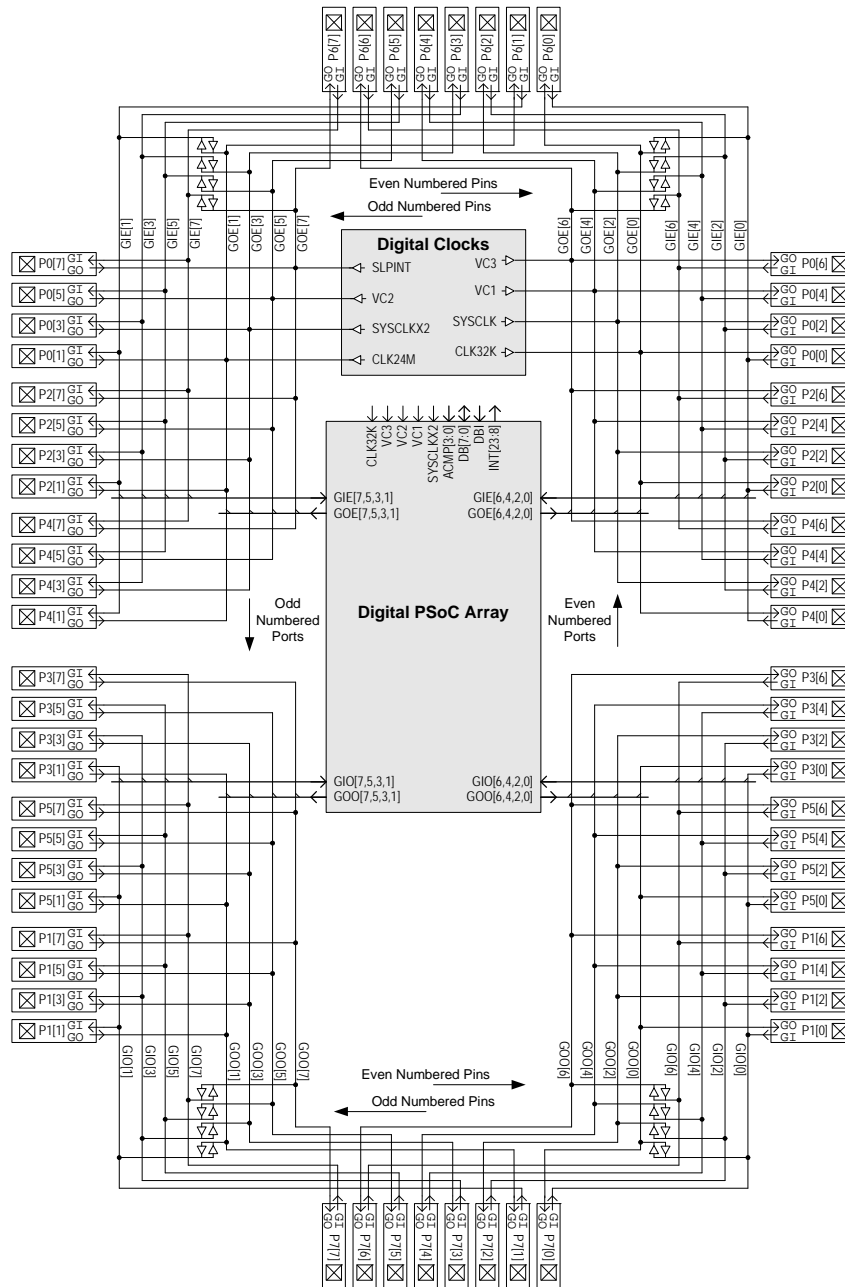

Figure 14-9. Global Interconnect Block Diagram for a 100-Pin Package

14.2 Register Definitions

The following registers are associated with the Global Digital Interconnect and are listed in address order. Each register description has an associated register table showing the bit structure for that register. For a complete table of GDI registers, refer to the “Summary Table of the Digital Registers” on page 308.

In the PSoC device with two digital rows, the configurable GDI is used to resynchronize the **feedback** between two digital PSoC blocks. This is accomplished by connecting a digital PSoC block’s output to a global output that has been configured to drive its corresponding global input. The global input is chosen to drive one of the row inputs. The row input is configured to synchronize the signal to the device’s 24 MHz system clock. Finally, the row input is used by the second digital PSoC block.

14.2.1 GDI_x_IN Registers

Addr.	Name	Rows	Bit 7	Bit 6	Bit 5	Bit 4	Bit 3	Bit 2	Bit 1	Bit 0	Access
1,D0h	GDI_O_IN	4, 3, 2, 1	GIONOUT7	GIONOUT6	GIONOUT5	GIONOUT4	GIONOUT3	GIONOUT2	GIONOUT1	GIONOUT0	RW : 00
1,D1h	GDI_E_IN	4, 3, 2, 1	GIENOUT7	GIENOUT6	GIENOUT5	GIENOUT4	GIENOUT3	GIENOUT2	GIENOUT1	GIENOUT0	RW : 00

The Global Digital Interconnect Odd and Even Input Registers (GDI_x_IN) are used to configure a global input to drive a global output.

The PSoC device has a configurable Global Digital Interconnect (GDI). Note that the GDI_x_IN and GDI_x_OU registers should never have the same bits connected. This would result in multiple drivers of one bus.

Bits 7 to 0: GlxNOUTx. Using the configuration bits in the GDI_x_IN registers, a global input net may be configured to drive its corresponding global output net. For example,

$$GIE[7] \rightarrow GOE[7]$$

The configurability of the GDI does not allow odd and even nets or nets with different indexes to be connected. The following are examples of connections that are not possible in the PSoC devices.

$$GOE[7] \nrightarrow GIO[7]$$

$$GOE[0] \nrightarrow GIE[7]$$

There are a total of 16 bits that control the ability of global inputs to drive global outputs. These bits are in the GDI_x_IN registers. Table 14-10 enumerates the meaning of each bit position in either of the GDI_O_IN or GDI_E_IN registers.

Table 14-10. GDI_x_IN Register

GDI_x_IN[0]	0: No connection between Glx[0] to GOx[0] 1: Allow Glx[0] to drive GOx[0]
GDI_x_IN[1]	0: No connection between Glx[1] to GOx[1] 1: Allow Glx[1] to drive GOx[1]
GDI_x_IN[2]	0: No connection between Glx[2] to GOx[2] 1: Allow Glx[2] to drive GOx[2]
GDI_x_IN[3]	0: No connection between Glx[3] to GOx[3] 1: Allow Glx[3] to drive GOx[3]
GDI_x_IN[4]	0: No connection between Glx[4] to GOx[4] 1: Allow Glx[4] to drive GOx[4]
GDI_x_IN[5]	0: No connection between Glx[5] to GOx[5] 1: Allow Glx[5] to drive GOx[5]
GDI_x_IN[6]	0: No connection between Glx[6] to GOx[6] 1: Allow Glx[6] to drive GOx[6]
GDI_x_IN[7]	0: No connection between Glx[7] to GOx[7] 1: Allow Glx[7] to drive GOx[7]

For additional information, refer to the GDI_O_IN register on page 283 and the GDI_E_IN register on page 284.

14.2.2 GDI_x_OU Registers

Addr.	Name	Rows	Bit 7	Bit 6	Bit 5	Bit 4	Bit 3	Bit 2	Bit 1	Bit 0	Access
1,D2h	GDI_O_OU	4, 3, 2, 1	GOOUTIN7	GOOUTIN6	GOOUTIN5	GOOUTIN4	GOOUTIN3	GOOUTIN2	GOOUTIN1	GOOUTIN0	RW : 00
1,D3h	GDI_E_OU	4, 3, 2, 1	GOEUTIN7	GOEUTIN6	GOEUTIN5	GOEUTIN4	GOEUTIN3	GOEUTIN2	GOEUTIN1	GOEUTIN0	RW : 00

The Global Digital Interconnect Odd and Even Output Registers (GDI_x_OU) are used to configure a global output to drive a global input.

The PSoC device has a configurable Global Digital Interconnect (GDI). Note that the GDI_x_IN and GDI_x_OU registers should never have the same bits connected. This would result in multiple drivers of one bus.

Bits 7 to 0: GOxUTINx. Using the configuration bits in the GDI_x_OU registers, a global output net may be configured to drive its corresponding global input. For example,

$$GOE[7] \rightarrow GIE[7]$$

The configurability of the GDI does not allow odd and even nets or nets with different indexes to be connected. The following are examples of connections that are not possible in the PSoC devices.

$$GOE[7] \nrightarrow GIO[7]$$

$$GOE[0] \nrightarrow GIE[7]$$

There are a total of 16 bits that control the ability of global outputs to drive global inputs. These bits are in the GDI_x_OU registers. [Table 14-11](#) enumerates the meaning of each bit position in either of the GDI_O_OU or GDI_E_OU registers.

Table 14-11. GDI_x_OU Register

GDI_x_OU[0]	0: No connection between Glx[0] to GOx[0] 1: Allow GOx[0] to drive Glx[0]
GDI_x_OU[1]	0: No connection between Glx[1] to GOx[1] 1: Allow GOx[1] to drive Glx[1]
GDI_x_OU[2]	0: No connection between Glx[2] to GOx[2] 1: Allow GOx[2] to drive Glx[2]
GDI_x_OU[3]	0: No connection between Glx[3] to GOx[3] 1: Allow GOx[3] to drive Glx[3]
GDI_x_OU[4]	0: No connection between Glx[4] to GOx[4] 1: Allow GOx[4] to drive Glx[4]
GDI_x_OU[5]	0: No connection between Glx[0] to GOx[5] 1: Allow GOx[5] to drive Glx[5]
GDI_x_OU[6]	0: No connection between Glx[6] to GOx[6] 1: Allow GOx[6] to drive Glx[6]
GDI_x_OU[7]	0: No connection between Glx[7] to GOx[7] 1: Allow GOx[7] to drive Glx[7]

For additional information, refer to the [GDI_O_OU register](#) on page 285 and the [GDI_E_OU register](#) on page 286.

15. Array Digital Interconnect (ADI)



This chapter presents the Array Digital Interconnect (ADI). The digital PSoC array uses a scalable architecture that is designed to support from one to four digital PSoC rows, as defined in the [Row Digital Interconnect \(RDI\)](#) chapter on page 327. The digital PSoC array does not have any configurable interconnect; therefore, there are no associated registers in this chapter.

15.1 Architectural Description

The Array Digital Interconnect (ADI) is shown in [Figure 15-1](#). The array structure varies depending on the number of digital rows your PSoC device has (see the table titled “PSoC Device Characteristics” on page 307). The ADI is not configurable; therefore, the information in this chapter is provided to improve the reader’s understanding of the structure.

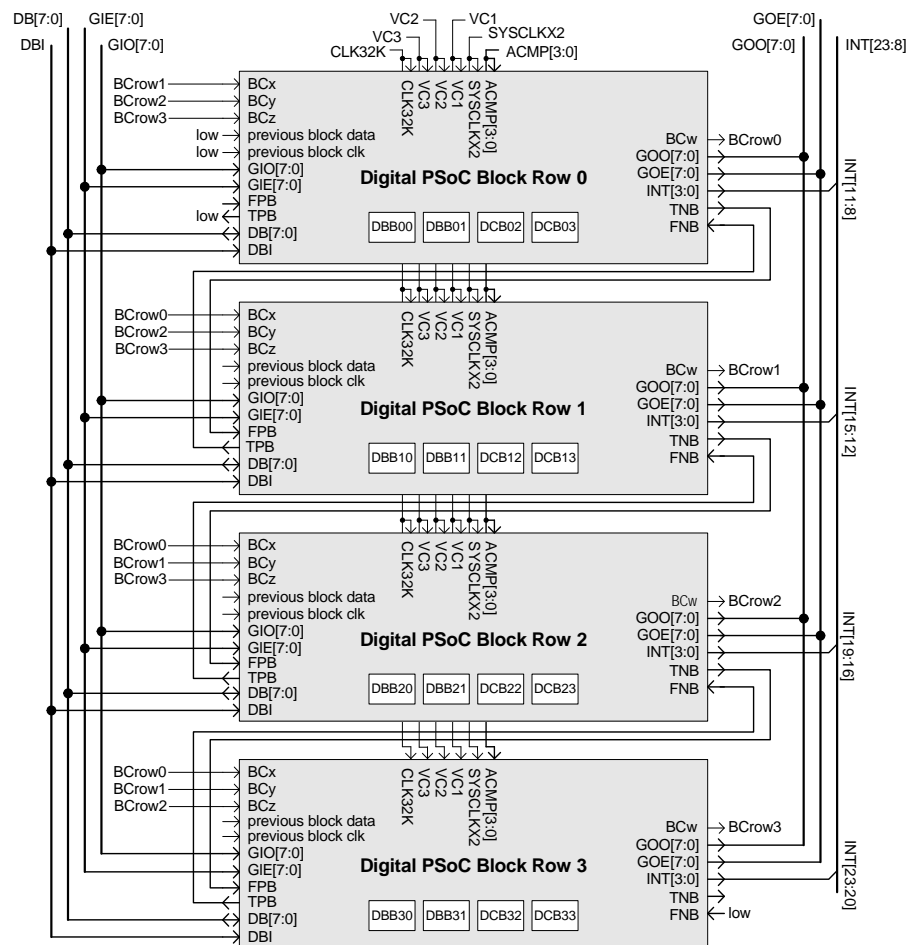

Figure 15-1. Digital PSoC Block Array Structure

In [Figure 15-1](#), the detailed view of a Digital PSoC block row has been replaced by a box labeled digital PSoC block row x. The rest of this figure illustrates how all rows are connected to the same globals, clocks, and so on. The figure also illustrates how the broadcast clock nets (BCrowx) are connected between rows.

The different PSoC CY8C2xxxx devices (except for the CY8C25122 and CY8C26xxx PSoC devices) have varying numbers of digital PSoC blocks in the digital array. These blocks are arranged into rows and the ADI provides a regular interconnect architecture between the Global Digital Interconnect (GDI) and the Row Digital Interconnect (RDI), regardless of the number of rows available in a particular device. The most important aspect of the ADI and the digital PSoC rows is that all digital PSoC rows have the same connections to global inputs and outputs. The connections that make a row's position unique are explained as follows.

- **Register Address:** Rows and the blocks within them need to have unique register addresses.
- **Interrupt Priority:** Each digital PSoC block has its own interrupt priority and vector. A row's position in the array determines the relative priority of the digital PSoC blocks within the row. The lower the row number, the higher the interrupt priority, and the lower the interrupt vector address.
- **Broadcast:** Each digital PSoC row has an internal **broadcast net** that may be either driven internally, by one of the four digital PSoC blocks, or driven externally. In the case where the broadcast net is driven externally, the source may be any one of the other rows in the array. Therefore, depending on the row's position in the array, it will have different options for driving its broadcast net.
- **Chaining Position:** Rows in the array form a string of digital blocks equal in length to the number of rows multiplied by four. The first block in the first row and the last block in the last row are not connected; therefore, the array does not form a loop. The first row in the array has its previous **chaining** inputs tied low. If there is a second row in the array, the next chaining outputs are connected to the next row. For the last row in the array, the next inputs are tied low.

16. Row Digital Interconnect (RDI)



This chapter explains the Row Digital Interconnect (RDI) and its associated registers. This chapter discusses a single digital PSoC block row. It does not discuss the functions, inputs, or outputs for individual digital PSoC blocks; nor does it cover specific instances of multiple rows in a single part. Therefore, the information contained here is valid for 4, 2, and 1 row configurations. Information about individual digital PSoC blocks is covered in the [Digital Blocks](#) chapter on page 335. For a complete table of the RDI registers, refer to the [“Summary Table of the Digital Registers”](#) on page 308. For a quick reference of all PSoC registers in address order, refer to the [Register Details](#) chapter on page 147.

16.1 Architectural Description

Many signals pass through the digital PSoC block row on their way to or from individual **digital blocks**. However, only a small number of signals pass through configurable circuits on their way to and from digital blocks. The configurable circuits allow for greater flexibility in the connections between digital blocks and global buses. What follows is a discussion of the signals that are configurable by way of the registers listed in the [“Register Definitions”](#) on page 329.

In [Figure 16-1](#), within a digital PSoC block row, there are four digital PSoC Blocks. The first two blocks are of the type basic (DBB). The second two are of the type communication

(DCB). This figure shows the connections between digital blocks within a row. Only the signals that pass outside the gray background box in [Figure 16-1](#) are shown at the next level of hierarchy in [Figure 16-2](#) on page 328.

In [Figure 16-2](#), the detailed view shown in [Figure 16-1](#) of the four PSoC block grouping, has been replaced by the box in the center of the figure labeled [“4 PSoC Block Grouping.”](#) The rest of the configurable nature of the Row Inputs (RI), Row Outputs (RO), and Broadcast clock net (BC) is shown for the next level of hierarchy.

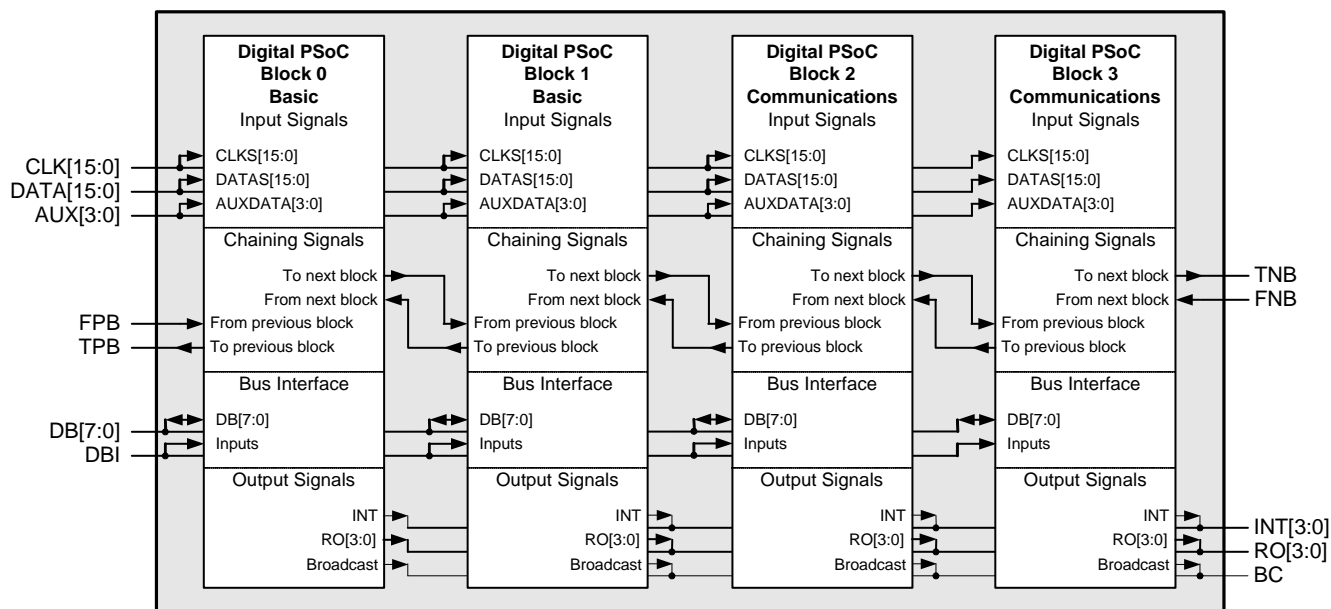

Figure 16-1. Detailed View of Four PSoC Block Grouping

As shown in Figure 16-2, there is a **keeper** connected to the row **broadcast net** and each of the row outputs. The keeper sets the value of these nets to '1' on system reset and holds the value of the net should it become un-driven.

output of these muxes are Row Inputs (RI[x]). Because there are four 4-to-1 muxes, each with a unique set of inputs, a row has access to every global input line in a PSoC device.

Notice on the left side of Figure 16-2 that global inputs (GIE[n] and GIO[n]) are inputs to 4-to-1 multiplexers. The

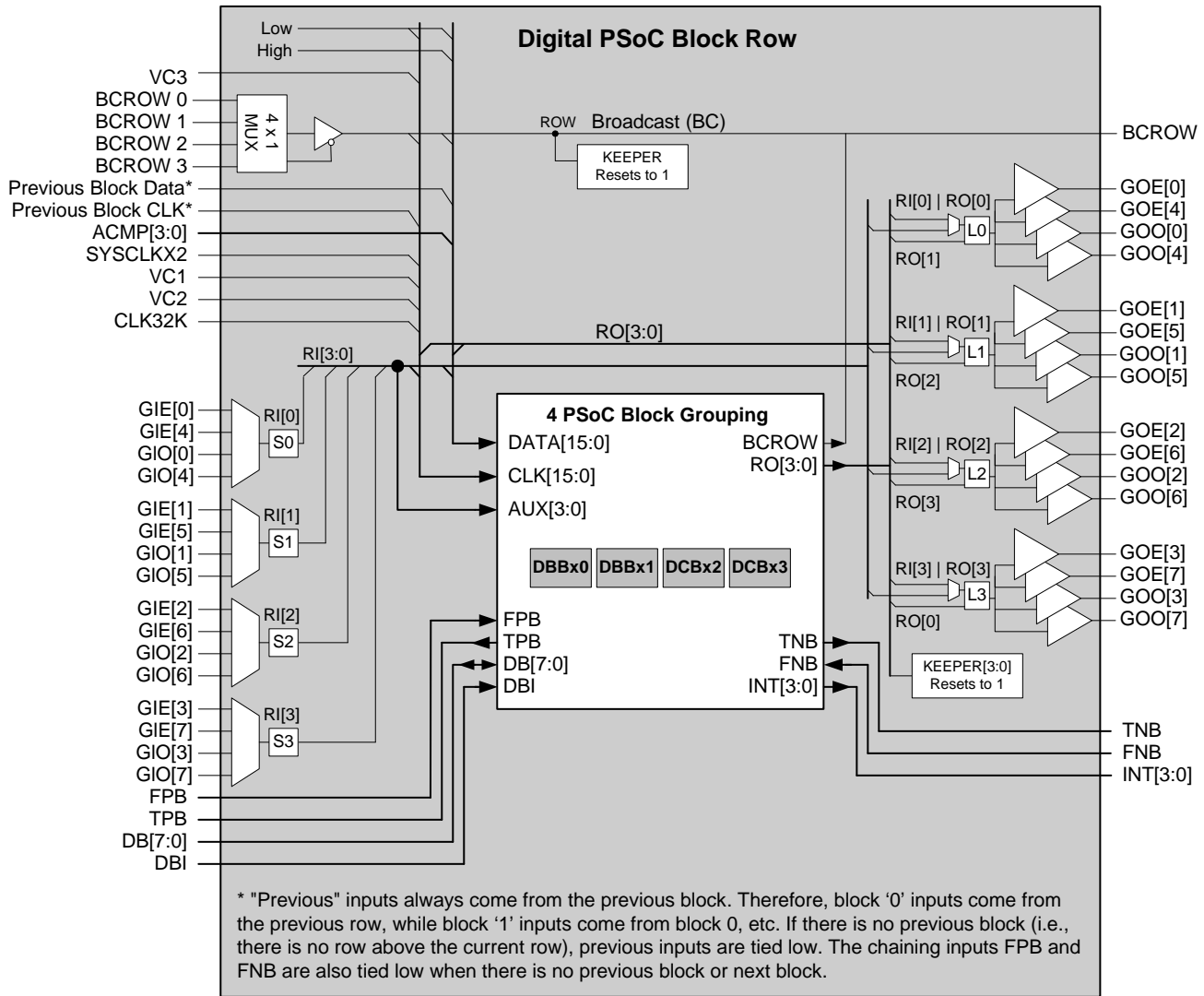

Figure 16-2. Digital PSoC Block Row Structure

16.2 PSoC Device Distinctions

For Silicon Revision A of the CY8C27x43 PSoC device, only digital blocks 01, 02, 11, and 12 are valid in the DEC_CR1 register. See the DEC_CR1 register on page 247 for more information.

16.3 Register Definitions

The following registers are associated with the Row Digital Interconnect (RDI) and are listed in address order. Each register description has an associated register table showing the bit structure for that register. For a complete table of RDI registers, refer to the “[Summary Table of the Digital Registers](#)” on page 308.

Depending on how many digital rows your PSoC device has (see the Rows column in the register tables below and refer to the table titled “[PSoC Device Characteristics](#)” on page 307), only certain bits are accessible to be read or written. The bits that are grayed out throughout this manual are reserved bits and are not detailed in the register descriptions that follow. Reserved bits should always be written with a value of ‘0’.

The only configurable inputs to a digital PSoC block row are the Global Input Even and Global Input Odd 8-bit buses. The only configurable outputs from the digital PSoC block row are the Global Output Even and Global Output Odd 8-bit buses. [Figure 16-2 on page 328](#) illustrates the relationships between global signals and row signals.

16.3.1 RDIXRI Register

Add.	Name	Rows	Bit 7	Bit 6	Bit 5	Bit 4	Bit 3	Bit 2	Bit 1	Bit 0	Access
x,B0h	RD10RI	4, 3, 2, 1	RI3[1:0]		RI2[1:0]		RI1[1:0]		RI0[1:0]		RW : 00
x,B8h	RD11RI	4, 3, 2	RI3[1:0]		RI2[1:0]		RI1[1:0]		RI0[1:0]		RW : 00
x,C0h	RD12RI	4, 3	RI3[1:0]		RI2[1:0]		RI1[1:0]		RI0[1:0]		RW : 00
x,C8h	RD13RI	4	RI3[1:0]		RI2[1:0]		RI1[1:0]		RI0[1:0]		RW : 00

LEGEND

x An “x” before the comma in the address field indicates that the register exists in both register banks.

The Row Digital Interconnect Row Input Register (RDIXRI) is used to control the input mux that determines which global inputs will drive the row inputs.

The RDIXRI Register and the [RDIXSYN Register](#) are the only two registers that affect digital PSoC row input signals. All other registers are related to output signal configuration.

The RDIXRI register has select bits that are used to control four muxes, where “x” denotes a place holder for the row index. [Table 16-1](#) lists the meaning for each mux’s four possible settings.

Bits 7 and 6: RI3[1:0]. These bits control the input mux for row 3.

Bits 5 and 4: RI2[1:0]. These bits control the input mux for row 2.

Bits 3 and 2: RI1[1:0]. These bits control the input mux for row 1.

Bits 1 and 0: RI0[1:0]. These bits control the input mux for row 0.

Table 16-1. RDIXRI Register

RI3[1:0]	0h: GIE[3] 1h: GIE[7] 2h: GIO[3] 3h: GIO[7]
RI2[1:0]	0h: GIE[2] 1h: GIE[6] 2h: GIO[2] 3h: GIO[6]
RI1[1:0]	0h: GIE[1] 1h: GIE[5] 2h: GIO[1] 3h: GIO[5]
RI0[1:0]	0h: GIE[0] 1h: GIE[4] 2h: GIO[0] 3h: GIO[4]

For additional information, refer to the [RDIXRI register](#) on [page 212](#).

16.3.2 RDIxSYN Register

Addr.	Name	Rows	Bit 7	Bit 6	Bit 5	Bit 4	Bit 3	Bit 2	Bit 1	Bit 0	Access
x,B1h	RDI0SYN	4, 3, 2, 1					RI3SYN	RI2SYN	RI1SYN	RI0SYN	RW : 00
x,B9h	RDI1SYN	4, 3, 2					RI3SYN	RI2SYN	RI1SYN	RI0SYN	RW : 00
x,C1h	RDI2SYN	4, 3					RI3SYN	RI2SYN	RI1SYN	RI0SYN	RW : 00
x,C9h	RDI3SYN	4					RI3SYN	RI2SYN	RI1SYN	RI0SYN	RW : 00

LEGEND

x An “x” before the comma in the address field indicates that the register exists in both register banks.

The Row Digital Interconnect Synchronization Register (RDIxSYN) is used to control the input synchronization.

The [RDIxRI Register](#) and the RDIxSYN Register are the only two registers that affect digital PSoC row input signals. All other registers are related to output signal configuration.

By default, each row input is double synchronized to the SYSCLK (system clock), which runs at 24 MHz unless external clocking mode is enabled. However, a user may choose to disable this synchronization by setting the appropriate RIxSYN bit in the RDIxSYN register. [Table 16-2](#) lists the bit meanings for each implemented bit of the RDIxSYN register.

Bit 3: RI3SYN. This bit controls the input synchronization for row 3.

Bit 2: RI2SYN. This bit controls the input synchronization for row 2.

Bit 1: RI1SYN. This bit controls the input synchronization for row 1.

Bit 0: RI0SYN. This bit controls the input synchronization for row 0.

Table 16-2. RDIxSYN Register

RI3SYN	0: Row input 3 is synchronized to SYSCLK 1: Row input 3 is passed without synchronization
RI2SYN	0: Row input 2 is synchronized to SYSCLK 1: Row input 2 is passed without synchronization
RI1SYN	0: Row input 1 is synchronized to SYSCLK 1: Row input 1 is passed without synchronization
RI0SYN	0: Row input 0 is synchronized to SYSCLK 1: Row input 0 is passed without synchronization

For additional information, refer to the [RDIxSYN register on page 213](#).

16.3.3 RDIxIS Register

Add.	Name	Rows	Bit 7	Bit 6	Bit 5	Bit 4	Bit 3	Bit 2	Bit 1	Bit 0	Access
x,B2h	RDI0IS	4, 3, 2, 1			BCSEL[1:0]		IS3	IS2	IS1	IS0	RW : 00
x,BAh	RDI1IS	4, 3, 2			BCSEL[1:0]		IS3	IS2	IS1	IS0	RW : 00
x,C2h	RDI2IS	4, 3			BCSEL[1:0]		IS3	IS2	IS1	IS0	RW : 00
x,CAh	RDI3IS	4			BCSEL[1:0]		IS3	IS2	IS1	IS0	RW : 00

LEGEND

x An "x" before the comma in the address field indicates that the register exists in both register banks.

The Row Digital Interconnect Input Select Register (RDIxIS) is used to configure the A inputs to the digital row LUTs and select a broadcast driver from another row if present.

Each LUT has two inputs, where one of the inputs is configurable (Input A) and the other input (Input B) is fixed to a row output. Figure 16-3 presents an example of LUT configuration.

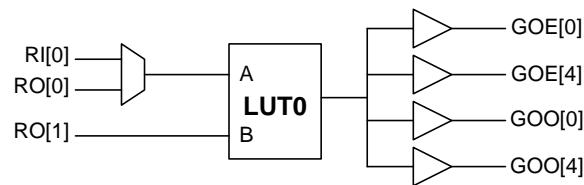

Figure 16-3. Example of LUT0 Configuration

These bits are the Input B for the **look-up table (LUT)**. The configurable LUT input (Input A) chooses between a single row output and a single row input. Table 16-3 lists the options for each LUT in a row. The bits are labeled IS, meaning Input Select. The LUT's fixed input is always the RO[LUT number + 1], such as LUT0's fixed input is RO[1], LUT1's fixed input is RO[2], ..., and LUT3's fixed input is RO[0].

Bits 5 and 4: BCSEL[1:0]. These bits are used to determine which digital PSoC row will drive the local broadcast net. If a row number is selected that does not exist, the broadcast net is driven to a logic 1 value. If any digital PSoC block in the local row has its DxBxFN[BCEN] bit set, the broadcast select is disabled. See the "DxBxxFN Registers" on page 352.

Bit 3: IS3. This bit controls the 'A' input of LUT 3.

Bit 2: IS2. This bit controls the 'A' input of LUT 2.

Bit 1: IS1. This bit controls the 'A' input of LUT 1.

Bit 0: IS0. This bit controls the 'A' input of LUT 0.

Table 16-3. RDIxIS Register Bits

BCSEL[1:0]	0: Row broadcast net driven by row 0 broadcast net.* 1: Row broadcast net driven by row 0 broadcast net.* 2: Row broadcast net driven by row 0 broadcast net.* 3: Row broadcast net driven by row 0 broadcast net.*
IS3	0: The 'A' input of LUT3 is RO[3] 1: The 'A' input of LUT3 is RI[3]
IS2	0: The 'A' input of LUT2 is RO[2] 1: The 'A' input of LUT2 is RI[2]
IS1	0: The 'A' input of LUT1 is RO[1] 1: The 'A' input of LUT1 is RI[1]
IS0	0: The 'A' input of LUT0 is RO[0] 1: The 'A' input of LUT0 is RI[0]
* When the BCSEL value is equal to the row number, the tri-state buffer that drives the row broadcast net from the input select mux is disabled, so that one of the row's blocks may drive the local row broadcast net. * Refer to Figure 16-2 on page 328. * If the row is not present in the part, the selection provides a logic 1 value.	

For additional information, refer to the RDIxIS register on page 214.

16.3.4 RDIxLTx Registers

Addr.	Name	Rows	Bit 7	Bit 6	Bit 5	Bit 4	Bit 3	Bit 2	Bit 1	Bit 0	Access
x,B3h	RDI0LT0	4, 3, 2, 1	LUT1[3:0]				LUT0[3:0]				RW : 00
x,B4h	RDI0LT1	4, 3, 2, 1	LUT3[3:0]				LUT2[3:0]				RW : 00
x,BBh	RDI1LT0	4, 3, 2	LUT1[3:0]				LUT0[3:0]				RW : 00
x,BCh	RDI1LT1	4, 3, 2	LUT3[3:0]				LUT2[3:0]				RW : 00
x,C3h	RDI2LT0	4, 3	LUT1[3:0]				LUT0[3:0]				RW : 00
x,C4h	RDI2LT1	4, 3	LUT3[3:0]				LUT2[3:0]				RW : 00
x,CBh	RDI3LT0	4	LUT1[3:0]				LUT0[3:0]				RW : 00
x,CCh	RDI3LT1	4	LUT3[3:0]				LUT2[3:0]				RW : 00

LEGEND

x An "x" before the comma in the address field indicates that the register exists in both register banks.

The Row Digital Interconnect Logic Table Register 0 and 1 (RDIxLT0 and RDIxLT1) are used to select the logic function of the digital row LUTs.

The outputs from a digital PSoC row are a bit more complicated than the inputs. Figure 16-2 on page 328 illustrates the output circuitry in a digital PSoC row. In the figure, find a block labeled Lx. This block represents a 2-input look-up table (LUT). The LUT allows the user to specify any one of 16 logic functions that should be applied to the two inputs.

The output of the logic function will determine the value that may be driven on to the Global Output Even and Global Output Odd buses. Table 16-4 lists the relationship between a look-up table's four configuration bits and the resulting logic function. Some users may find it easier to determine the proper configuration bits setting, by remembering that the configuration's bits represent the output column of a two-input logic truth table. Table 16-4 lists seven examples of the relationship between the LUT's output column for a truth table and the LUTx[3:0] configuration bits. Figure 16-3 on page 331 presents an example of LUT configuration.

Bits 7 to 4: LUTx[3:0]. These configuration bits are for a row output LUT.

Bits 3 to 0: LUTx[3:0]. These configuration bits are for a row output LUT.

For additional information, refer to the RDIxLT0 register on page 215 and the RDIxLT1 register on page 216.

Table 16-4. Example LUT Truth Tables

A	B	AND	OR	A+B	A&B	A	B	True
0	0	0	0	1	0	0	0	1
0	1	0	1	0	0	0	1	1
1	0	0	1	1	1	1	0	1
1	1	1	1	1	0	1	1	1
LUTx[3:0]		1h	7h	Bh	2h	3h	5h	Fh

Table 16-5. RDIxLTx Register

LUTx[3:0]	0h: 0000: FALSE 1h: 0001: A .AND. B 2h: 0010: A .AND. B̄ 3h: 0011: Ā 4h: 0100: A .AND. B 5h: 0101: B 6h: 0110: A .XOR. B 7h: 0111: A .OR. B 8h: 1000: A .NOR. B 9h: 1001: Ā .XNOR. B Ah: 1010: B Bh: 1011: Ā .OR. B̄ Ch: 1100: Ā Dh: 1101: Ā .OR. B Eh: 1110: A .NAND. B Fh: 1111: TRUE
-----------	---

16.3.5 RDIxROx Registers

Add.	Name	Rows	Bit 7	Bit 6	Bit 5	Bit 4	Bit 3	Bit 2	Bit 1	Bit 0	Access
x,B5h	RDI0RO0	4, 3, 2, 1	GOO5EN	GOO1EN	GOE5EN	GOE1EN	GOO4EN	GOO0EN	GOE4EN	GOE0EN	RW : 00
x,B6h	RDI0RO1	4, 3, 2, 1	GOO7EN	GOO3EN	GOE7EN	GOE3EN	GOO6EN	GOO2EN	GOE6EN	GOE2EN	RW : 00
x,BDh	RDI1RO0	4, 3, 2	GOO5EN	GOO1EN	GOE5EN	GOE1EN	GOO4EN	GOO0EN	GOE4EN	GOE0EN	RW : 00
x,BEh	RDI1RO1	4, 3, 2	GOO7EN	GOO3EN	GOE7EN	GOE3EN	GOO6EN	GOO2EN	GOE6EN	GOE2EN	RW : 00
x,C6h	RDI2RO1	4, 3	GOO7EN	GOO3EN	GOE7EN	GOE3EN	GOO6EN	GOO2EN	GOE6EN	GOE2EN	RW : 00
x,C5h	RDI2RO0	4, 3	GOO5EN	GOO1EN	GOE5EN	GOE1EN	GOO4EN	GOO0EN	GOE4EN	GOE0EN	RW : 00
x,CDh	RDI3RO0	4	GOO5EN	GOO1EN	GOE5EN	GOE1EN	GOO4EN	GOO0EN	GOE4EN	GOE0EN	RW : 00
x,CEh	RDI3RO1	4	GOO7EN	GOO3EN	GOE7EN	GOE3EN	GOO6EN	GOO2EN	GOE6EN	GOE2EN	RW : 00

LEGEND

x An "x" before the comma in the address field indicates that the register exists in both register banks.

The Row Digital Interconnect Row Output Register 0 and 1 (RDIxRO0 and RDIxRO1) are used to select the global nets that the row outputs drive.

The final configuration bits for outputs from digital PSoC rows are in the two RDIxROx registers. These registers hold the 16 bits that can individually enable the tri-state buffers that connect to all eight of the Global Output Even lines and all eight of the Global Output Odd lines to the row LUTs.

The input to these tri-state drivers are the outputs of the row's LUTs, as shown in [Figure 16-2](#). This means that any row can drive any global output. Keep in mind that tri-state drivers are being used to drive the global output lines; therefore, it is possible for a part, with more than one digital PSoC row, to have multiple drivers on a single global output line. It is the user's responsibility to ensure that the part is not configured with multiple drivers on any of the global output lines. [Figure 16-3 on page 331](#) presents an example LUT configuration.

16.3.5.1 RDIxRO0 Register

Bits 7 to 4: GOxxEN. These configuration bits enable the tri-state buffers that connect to the global output even lines for LUT 1.

Bits 3 to 0: GOxxEN. These configuration bits enable the tri-state buffers that connect to the global output even lines for LUT 0.

For additional information, refer to the [RDIxRO0 register on page 217](#).

16.3.5.2 RDIxRO1 Register

Bits 7 to 4: GOxxEN. These configuration bits enable the tri-state buffers that connect to the global output even lines for LUT 3.

Bits 3 to 0: GOxxEN. These configuration bits enable the tri-state buffers that connect to the global output even lines for LUT 2.

For additional information, refer to the [RDIxRO1 register on page 218](#).

16.4 Timing Diagram

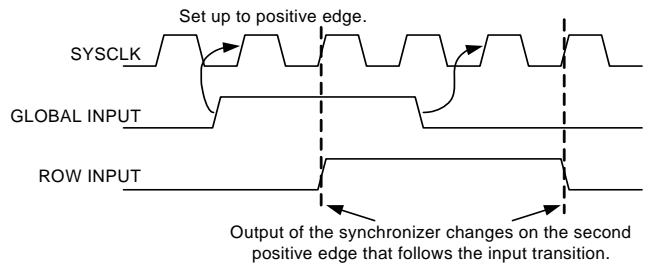

Figure 16-4. Optional Row Input Synchronization to SYSCLK

17. Digital Blocks



This chapter covers the configuration and use of the digital PSoC blocks and their associated registers. For a complete table of the Digital PSoC Block registers, refer to the “[Summary Table of the Digital Registers](#)” on page 308. For a quick reference of all PSoC registers in address order, refer to the [Register Details](#) chapter on page 147.

17.1 Architectural Description

At the top level, the main components of the digital block are the data path, input multiplexers (muxes), output de-muxes, configuration registers, and chaining signals (see [Figure 17-1](#)).

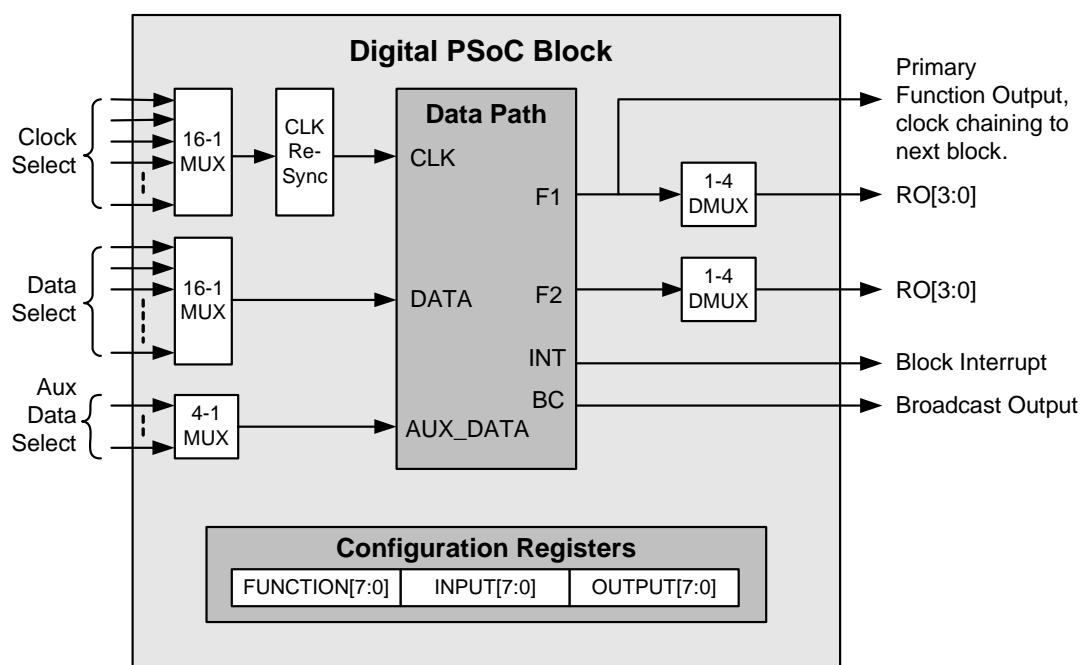

Figure 17-1. Digital Blocks Top Level Block Diagram

All digital PSoC blocks may be configured to perform any one of five basic functions: timer, counter, **pulse width modulator (PWM)**, pseudo random sequence (PRS), or **cyclic redundancy check (CRC)**. These functions may be used by configuring an individual PSoC block or chaining several PSoC blocks together to form functions that are greater than 8 bits. Digital communications PSoC blocks have two additional functions: master or slave SPI and a full duplex **UART**.

Each digital PSoC block's function is independent of all other PSoC blocks. Up to seven registers are used to determine the function and state of a digital PSoC block. These registers are discussed in the [Register Definitions](#) section. Digital PSoC block function registers end with FN. The individual bit settings for a block's function register are listed in [Table 17-14](#) on page 352. The input registers end with IN and its bit meanings are listed in [Table 17-16](#) on page 353. Finally, the block's outputs are controlled by the output register which ends in OU.

Each digital PSoC block also has three data registers (DR0, DR1, and DR2) and one control register (CR0). The bit meanings for these registers are heavily function dependent and are discussed with each function's description.

In addition to seven registers that control the digital PSoC block's function and state, a separate interrupt mask bit is available for each digital PSoC block. Each digital PSoC block has a unique interrupt vector; and therefore, it can have its own interrupt service routine.

17.1.1 Input Multiplexers

Typically, each function has a clock and a data input that may be selected from a variety of sources. Each of these inputs is selected with a 16-to-1 input mux.

In addition, there is a 4-to-1 mux which provides an auxiliary input for the SPI Slave function that requires three inputs: Clock, Data, and SS_ (unless the SS_ is forced active with the Aux IO Enable bit). The inputs to this mux are intended to be a selection of the row inputs.

17.1.2 Input Clock Resynchronization

Digital blocks allow a clock selection from one of 16 sources. Possible sources are the system clocks (VC1, VC2, VC3, SYSCLK, and SYSCLKX2), row inputs, and other digital block outputs. To manage clock *skew* and ensure that the interfaces between blocks meet timing in all cases, all digital block input clocks must be resynchronized to either SYSCLK or SYSCLKX2, which are the source clocks for all the PSoC device clocking. Also, SYSCLK or SYSCLKX2 may be used directly. The AUXCLK bits in the DxBxxOU register are used to specify the input synchronization. The following rules apply to the use of input clock resynchronization.

1. If the clock input is derived (for example, divided down) from SYSCLK, re-synchronize to SYSCLK at the digital block. Most the PSoC device clocks are in this category. For example, VC1 and VC2, and the output of other blocks clocked by VC1 and VC2, or SYSCLK (for setting see [Table 17-1](#)).
2. If the clock input is derived from SYSCLKX2, re-synchronize to SYSCLKX2. For example, VC3 clocked by SYSCLKX2 or other digital blocks clocked by SYSCLKX2 (for setting see [Table 17-1](#)).
3. Choose direct SYSCLK for clocking directly off of SYSCLK (for setting see [Table 17-1](#)).
4. Choose direct SYSCLKX2 (select SYSCLKX2 in the Clock Input field of the DxBxxIN register) for clocking directly off of SYSCLKX2.

5. Bypass Synchronization. This should be a very rare selection; because if clocks are not synchronized, they may fail setup to CPU read and write commands. However, it is possible for an external pin to asynchronously clock a digital block. For example, if the user is willing to synchronize CPU interaction through interrupts or other techniques (setting 00 in AUXCLK). This setting is also required for blocks to remain active while in sleep.

The note below enumerates configurations that are not allowed, although the hardware does not prevent them. The clock dividers (VC1, VC2, and VC3) may not be configured in such a way as to create an output clock that is equal to SYSCLK or SYSCLKX2.

Note If the input clock frequency matches the frequency of the clock used for synchronization, the block will never receive a clock (see [Figure 17-2](#)). With respect to SYSCLK, this can happen in the following cases:

- Using VC1 configured as divide by one.
- Using VC2 with VC1 and VC2 both configured as divide by one.
- Using VC3 divided by one with a source of VC1 divided by one.
- Using VC3 divided by one with a source of VC2, where both VC1 and VC2 are divided by one.
- Using VC3 divided by one with SYSCLK source.

In all of these cases, SYSCLK should be selected directly in the block. Similarly, if VC3 is configured as divide by one with a source of SYSCLKX2, then SYSCLKX2 should be selected to clock the block directly instead of VC3.

The clock resynchronizer is illustrated in [Figure 17-2](#).

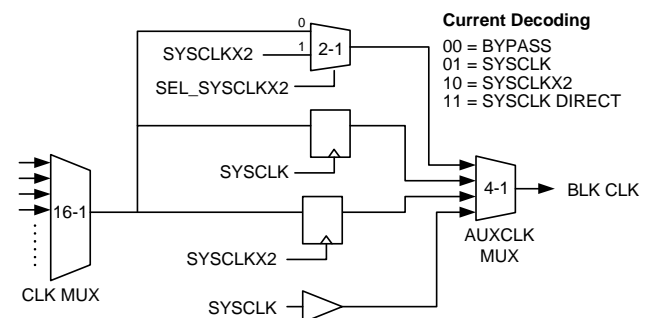

Figure 17-2. Input Clock Resynchronization

In sleep, SYSCLK is powered down, and therefore input synchronization is not available.

Table 17-1. AUXCLK Bit Selections

Code	Description	Usage
00	Bypass	Use this setting only when SYSCLKX2 (48 MHz) is selected. Other than this case, asynchronous clock inputs are not recommended. This setting is also required for blocks to remain active while in sleep.
01	Resynchronize to SYSCLK (24 MHz)	Use this setting for any SYSCLK-based clock. VC1, VC2, VC3 driven by SYSCLK, digital blocks with SYSCLK-based source clocks, broadcast bus with source based on SYSCLK, row input and row outputs with source based on SYSCLK.
10	Resynchronize to SYSCLKX2 (48 MHz)	Use this setting for any SYSCLKX2-based clock. VC3 driven by SYSCLKX2, digital blocks with SYSCLKX2-based source clocks, broadcast bus with source based on SYSCLKX2, row input and row outputs with source based on SYSCLKX2.
11	SYSCLK Direct	Use this setting to clock the block directly using SYSCLK. Note that this setting is not strictly related to clock resynchronization, but since SYSCLK cannot resync itself, it allows a direct skew controlled SYSCLK source.

17.1.2.1 Clock Resynchronization Summary

- Digital PSoC blocks have extremely flexible clocking configurations. To maintain reliable timing, input clocks must be resynchronized.
- The master clock for any clock in the system is either SYSCLK or SYSCLKX2. Determine the master clock for a given input clock and resynchronize to that clock.
- Do not use divide by 1 clocks derived from SYSCLK and SYSCLKX2. Use the direct SYSCLK or SYSCLKX2 clocking option available at the block.

17.1.3 Output De-Multiplexers

Most functions have two outputs: a primary and an auxiliary output, the meaning of which are function dependent. Each of these outputs may be driven onto the row output bus. Each de-mux is implemented with four tri-state drivers. There are two bits in the output register to select one of the four tri-state drivers and an additional bit to enable the selected driver.

17.1.4 Block Chaining Signals

Each digital block has the capability to be chained and to create functions with bit widths greater than eight. There are signals to propagate information, such as Compare, Carry, Enable, Capture and Gate, from one block to the next to implement higher precision functions. The selection made in the function register determines which signals are appropriate for the desired function. User Modules that have been designed to implement digital functions, with greater than 8-bit width, will automatically make the proper selections of the chaining signals, to ensure the correct information flow between blocks.

17.1.5 Input Data Synchronization

Any asynchronous input derived from an external source, such as a GPIO pin input, must be resynchronized through the row input before use into any digital block clock or data input. This is the default mode of operation (resynchronization).

17.1.6 Timer Function

A timer consists of a period register, a **synchronous** down counter, and a capture/compare register, all of which are byte wide. When the timer is disabled and a period value is written into DR1, the period value is also loaded into DR0. When the timer is enabled, the counter counts down until positive terminal count (a count of 00h) is reached. On the next clock edge, the period is reloaded and, on subsequent clocks, counting continues. The terminal count signal is the primary function output. (Refer to the timing diagram for this function on page 355.) This can be configured as a full or half clock cycle.

Hardware capture occurs on the positive edge of the data input. This event transfers the current count from DR0 to DR2. The captured value may then be read directly from DR2. A software capture function is equivalent to a hardware capture. A CPU read of DR0, with the timer enabled, triggers the same capture mechanism. The hardware and software capture mechanisms are OR'ed in the capture circuitry. Since the capture circuitry is positive edge sensitive, during an interval where the hardware capture input is high, a software capture is masked and will not occur.

The timer also implements a compare function between DR0 and DR2. The compare signal is the auxiliary function output. A limitation, in regards to the compare function, is that the capture and compare function both use the same register (DR2). Therefore, if a capture event occurs, it will overwrite the compare value.

Mode bit 1 in the function register sets the compare type ($DR0 \leq DR2$ or $DR0 < DR2$) and Mode bit 0 sets the interrupt type (Terminal Count or Compare).

Timers may be chained in 8-bit lengths up to 32 bits.

17.1.6.1 Usability Exceptions

The following are usability exceptions for the Timer function.

1. Capture operation is not supported at 48 MHz.
2. DR2 is not writeable when the Timer is enabled.

17.1.6.2 Block Interrupt

The Timer block has a selection of three interrupt sources. Interrupt on Terminal Count (TC) and Interrupt on Compare may be selected in Mode bit 0 of the function register. The third interrupt source, Interrupt on Capture, may be selected with the Capture Interrupt bit in the control register.

- **Interrupt on Terminal Count:** The positive edge of terminal count (primary output) generates an interrupt for this block. The timing of the interrupt follows the TC pulse width setting in the control register.
- **Interrupt on Compare:** The positive edge of compare (auxiliary output) generates an interrupt for this block.
- **Interrupt on Capture:** Hardware or software capture generates an interrupt for this block. The interrupt occurs at the closing of the DR2 latch on capture.

17.1.7 Counter Function

A Counter consists of a period register, a synchronous down counter, and a compare register. The Counter function is identical to the Timer function except for the following points:

- The data input is a counter gate (enable), rather than a capture input. Counters do not implement synchronous capture. The DR0 register in a counter should not be read when it is enabled.
- The compare output is the primary output and the Terminal Count (TC) is the auxiliary output (opposite of the Timer).
- Terminal count output is full cycle only.

When the counter is disabled and a period value is written into DR1, the period value is also loaded into DR0. When the counter is enabled, the counter counts down until terminal count (a count of 00h) is reached. On the next clock edge, the period is reloaded and, on subsequent clocks, counting continues. (Refer to the timing diagram for this function on page 356.)

The counter implements a compare function between DR0 and DR2. The Compare signal is the primary function output. Mode bit 1 sets the compare type ($DR0 \leq DR2$ or $DR0 < DR2$) and Mode bit 0 sets the interrupt type (terminal count or compare).

The data input functions as a gate to counter operation. The counter will only count and reload when the data input is asserted (logic 1). When the data input is negated (logic 0), counting (including the period reload) is halted.

Counters may be chained in 8-bit blocks up to 32 bits.

17.1.7.1 Usability Exceptions

The following is a usability exception for the Counter function.

1. DR0 may only be read (to transfer DR0 data to DR2) when the block is disabled.

17.1.7.2 Block Interrupt

The Counter block has a selection of two interrupt sources. Interrupt on Terminal Count (TC) and Interrupt on Compare may be selected in Mode bit 0 of the function register.

- **Interrupt on Terminal Count:** The positive edge of terminal count (auxiliary output) generates an interrupt for this block. The timing of the interrupt follows the TC pulse width setting in the control register.
- **Interrupt on Compare:** The positive edge of compare (primary output) generates an interrupt for this block.

17.1.8 Dead Band Function

The Dead Band function generates output signals on both the primary and auxiliary outputs of the block, see [Figure 17-3](#). Each of these outputs is one *phase* of a two-phase, non-overlapping clock generated by this function. The two clock phases are never high at the same time and the period between the clock phases is known as the **dead band**. The width of the dead band time is determined by the value in the period register. This dead band function can be driven with a PWM as an input clock or it can be clocked directly by toggling a bit in software using the Bit-Bang interface. If the clock source is a PWM, this will make a two output PWM with guaranteed non-overlapping outputs. An active asynchronous signal on the KILL data input disables both outputs immediately.

The PWM with the Dead Band User Module configures one or two blocks to create an 8- or 16-bit PWM and configures an additional block as the Dead Band function.

A dead band consists of a period register, a synchronous down counter, and a special dead band circuit. The DR2 register is only used to read the contents of DR0. As with the counter, when the dead band is disabled and a period value is written into DR1, the period value is also loaded into DR0. (Refer to the timing diagrams for this function on page 357.)

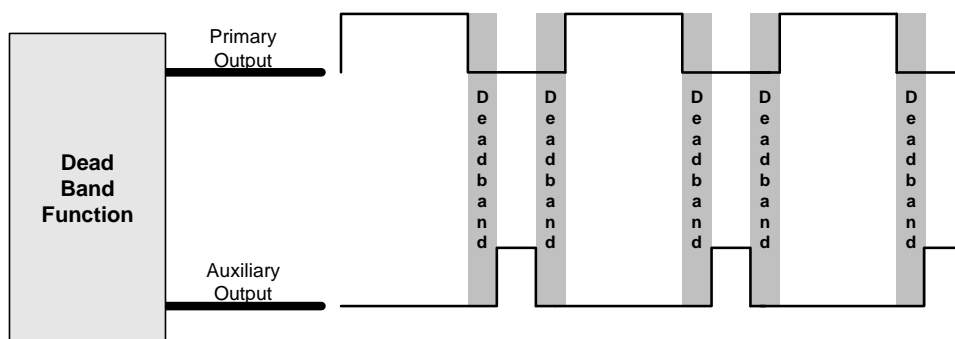

Figure 17-3. Dead Band Functional Overview

The dead band has two inputs: a PWM reference signal and a KILL signal. The PWM reference signal may be derived from one of two sources. By default, it is hardwired to be the primary output of the previous block. This previous block output is wired as an input to the 16-to-1 clock input mux. In the dead band case, as the previous block output is wired directly to the dead band reference input. If this mode is used, a PWM, or some other **waveform** generator, must be instantiated in the previous digital block. There is also an optional Bit Bang mode. In this mode, firmware toggles a register bit to generate a PWM reference; and therefore, the dead band may be used as a stand-alone block.

The KILL signal is derived from the data input signal to the block. Mode [1:0] is encoded as the Kill Type. In all cases when kill is asserted, the output is forced low immediately. Mode bits are encoded for kill options and are detailed in the following table.

Table 17-2. Dead Band Kill Options

Mode [1:0]	Description
00b	Synchronous Restart KILL mode. Internal state is reset and reference edges are ignored, until the KILL signal is negated.
01b	Disable KILL mode. Block is disabled. KILL signal must be negated and user must re-enable the block in firmware to resume operation.
10b	Asynchronous KILL mode. Outputs are low only for the duration that the KILL signal is asserted, subject to a minimum disable time between one-half to one and one-half clock cycles. Internal state is unaffected.
11b	Reserved

When the block is initially enabled, both outputs are low. After enabling, a positive or negative edge of the incoming PWM reference enables the counter. The counter counts down from the period value to terminal count. At terminal count, the counter is disabled and the selected phase is asserted high. On the opposite edge of the PWM input, the output that was high is negated low and the process is repeated with the opposite phase. This results in the generation of a two phase non-overlapping clock matching the frequency and pulse width of the incoming PWM reference, but separated by a dead time derived from the period and the input clock.

There is a deterministic relationship between the incoming PWM reference and the output phases. The positive edge of the reference causes the primary output to be asserted to '1' and the negative edge of the reference causes the auxiliary output to be asserted to '1'.

17.1.8.1 Usability Exceptions

The following are usability exceptions for the Dead Band function.

1. The Dead Band function may not be chained.
2. Programming a dead band period value of 00h is not supported. The block output is undefined under this condition.

3. If the period (of either the **high time** or the **low time** of the reference input) is less than the programmed dead time, than the associated output phase will be held low.
4. DR0 may only be read (to transfer DR0 data to DR2) when the block is disabled.
5. If the asynchronous KILL signal is being used in a given application, the output of the dead band cannot be connected directly to the input of another digital block in the same row. Since the kill is asynchronous, the digital block output must be resynchronized through a row input before using it as a digital block input.

17.1.8.2 Block Interrupt

The Dead Band block has one fixed interrupt source, which is the Phase 1 primary output clock. When the KILL signal is asserted, the interrupt follows the same behavior of the Phase 1 output with respect to the various KILL modes.

17.1.9 CRCPRS Function

A Cyclic Redundancy Check/Pseudo Random Sequence (CRCPRS) function consists of a polynomial register, a **Linear Feedback Shift Register (LFSR)**, and a seed register. (See Figure 17-4 on page 340.) When the CRCPRS block is disabled and a **seed value** is written into DR2, the seed value is also loaded into DR0. When the CRCPRS is enabled, and synchronous clock and data are applied to the inputs, a CRC is computed on the **serial** data input stream. When the data input is forced to '0', then the block functions as a pseudo random sequencer (PRS) generator with the output data generated at the clock rate. The most significant bit (MSb) of the CRCPRS function is the primary output.

The CRCPRS has a selection of compare modes between DR0 and DR2. The default behavior of the compare is DR0==DR2. When the PRS function cycles through the seed value as one of the valid counts, the compare output is asserted high for one clock cycle. This is regarded as the epoch of the pseudo random sequence. The mode bits can be used to set other compare types. Setting Mode bit 0 to '1' causes the compare behavior to revert to DR0 <= DR2 or DR0 < DR2, depending upon Mode bit 1. The compare value is the auxiliary output. An interrupt is generated on compare true.

CRCPRS mode offers an optional Pass function. By setting the Pass Mode bit in the CR0 register (bit 1), the CRCPRS function is overridden. In this mode, the data input is passed transparently to the primary output and an interrupt is generated on the rising of the data input. Similarly, the CLK input is passed transparently to the auxiliary output. This can only be used to pass signals to the global outputs. If the output of a pass function is needed as an input to another digital block, it must be resynchronized through the globals and row inputs.

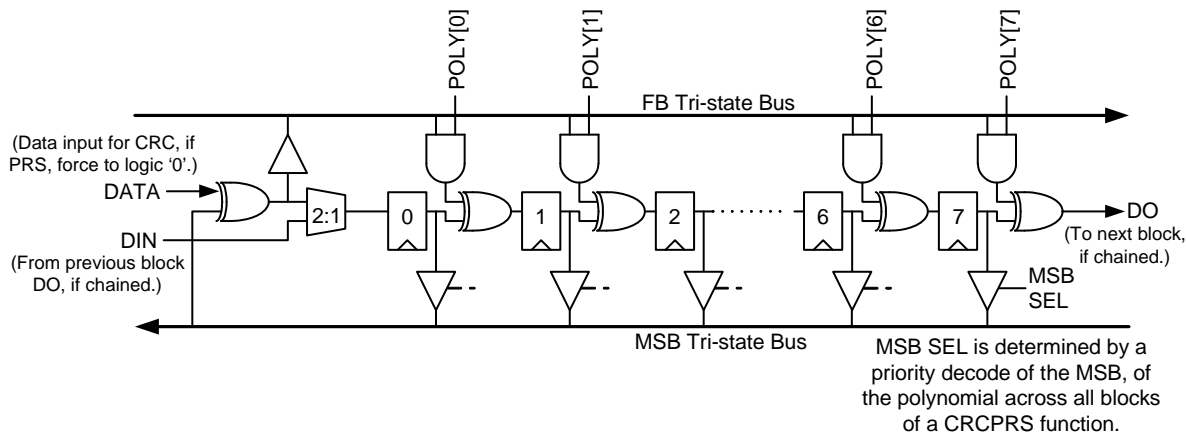

Figure 17-4. CRCPRS LFSR Structure

LSFR Structure

The LSFR (Linear Feedback Shift register) structure, as shown in Figure 17-4, is implemented as a modular **shift** register generator. The least significant block in the chain inputs the MSb and XORs it with the DATA input, in the case of CRC computation. For PRS computation, the DATA input is forced to logic 0 (by input selection); and therefore, the MSb bus is directly connected to the FB bus. In the case of a chained block, the data input (DIN) comes directly from the data output (DO) of the LFSR in the previous block. The MSb selection, derived from the priority decode of the polynomial, enables one of the tri-state drivers to drive the MSB bus.

Determining the CRC Polynomial

Computation of an n-bit result is generally specified by a polynomial with n+1 terms, the last of which is X_{16} , where

$$X_0 = 1 \quad \text{Equation 1}$$

As an example, the CRC-CCIT 16-bit polynomial is:

$$CRC - CCIT = X_{16} + X_{12} + X_5 + 1 \quad \text{Equation 2}$$

The CRCPRS hardware assumes the presence of the X_0 term; and therefore, this polynomial can be expressed in 16 bits as 1000100000010000 or 8810h. Two consecutive digital blocks may be allocated to perform this function, with 88h as the MS block polynomial (DR1) and 10h as the LS block polynomial value.

Determining the PRS Polynomial

Generally, PRS polynomials are selected from pre-computed reference tables. It is important to note that there are two common ways to specify a PRS polynomial: simple register configuration and modular configuration. In the simple method, a **shift register** is implemented with a reduction XOR of the MSb and feedback taps as input into the least significant bit. In the modular method, there is an XOR operation implemented between each register bit and each tap point enables the XOR with the MSb for that given bit. The CRCPRS function implements the modular approach.

These are equivalent methods. However, there is a conversion that should be understood. If tables are specified in simple register format, then a conversion can be made to the modular format by subtracting each tap from the MS tap, as shown in the following example.

To implement a 7-bit PRS of length 127, one possible code is [7,6,4,2]s, which is in simple format. The modular format would be [7,7-6,7-4,7-2]m or [7,1,3,5]m which is equivalent to [7, 5, 3, 1]. Determining the polynomial to program is similar to the CRC example above. Set a **binary** bit for each tap (with bit 0 of the register corresponding to tap 1). Therefore, the code [7,5,3,1] would correspond to 01010101 or 55h.

In both the CRC and PRS cases, an appropriate seed value should be selected. All ones for PRS, or all ones or all zeros for CRC are typical values. Note that a seed value of all zeros should not be used in a PRS function, because PRS counting is inhibited by this seed.

17.1.9.1 Usability Exceptions

The following is a usability exception for the CRCPRS function.

1. The polynomial register must only be written when the block is disabled.

17.1.9.2 Block Interrupt

The CRCPRS block has one fixed interrupt source, which is the compare auxiliary output.

17.1.10 SPI Protocol Function

The Serial Peripheral Interface (SPI) is a Motorola™ specification for implementing full-duplex synchronous serial communication between devices. The 3-wire **protocol** uses both edges of the clock to enable synchronous communication, without the need for stringent setup and hold requirements. Figure 17-5 shows the basic signals in a simple connection.

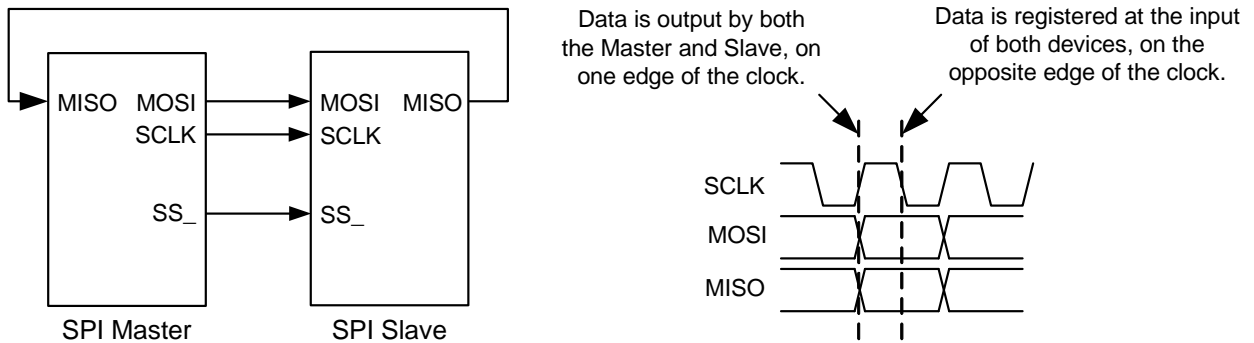

Figure 17-5. Basic SPI Configuration

A device can be a master or slave. A master outputs clock and data to the **slave device** and inputs slave data. A slave device inputs clock and data from the **master device** and outputs data for input to the master. The master and slave together are essentially a circular shift register, where the master is generating the clocking and initiating data transfers.

A basic data transfer occurs when the master sends eight bits of data, along with eight clocks. In any transfer, both master and slave are transmitting and receiving simultaneously. If the master is only sending data, the received data from the slave is ignored. If the master wishes to receive data from the slave, the master must send dummy bytes to generate the clocking for the slave to send data back.

17.1.10.1 SPI Protocol Signal Definitions

The SPI Protocol signal definitions are located in Table 17-3. The use of the SS_ signal varies according to the capability of the slave device.

Table 17-3. SPI Protocol Signal Definitions

Name	Function	Description
MOSI	Master Out Slave In	Master data output.
MISO	Master In Slave Out	Slave data output.
SCLK	Serial Clock	Clock generated by the master.
SS_	Slave Select (active low)	This signal is provided to enable multi-slave connections to the MISO pin. The MOSI and SCLK pins can be connected to multiple slaves, and the SS_ input selects which slave will receive the input data and drive the MISO line.

17.1.11 SPI Master Function

The SPI Master (SPIM) offers SPI operating modes 0-3. By default, the MSb of the data byte is shifted out first. An additional option can be set to reverse the direction and shift the data byte out LSb first. (Refer to the timing diagrams for this function on page 360.)

When configured for SPIM, DR0 functions as a shift register, with input from the DATA input (MISO) and output to the primary output F1 (MOSI). DR1 is the TX Buffer register and DR2 is the RX Buffer register.

The SPI protocol requires data to be registered at the device input, on the opposite edge of the clock that operates the output shifter. An additional register (RXD), at the input to the DR0 shift register, has been implemented for this purpose. This register stores received data for one-half cycle, before it is clocked into the shift register.

The SPIM controls **data transmission** between master and slave, because it generates the bit clock for internal clocking and for clocking the SPIS. The bit clock is derived from the CLK input selection. Since the PSoC system clock generators produce clocks with varying duty cycles, the SPIM divides the input CLK by two to produce a bit clock with a 50 percent duty cycle. This clock is gated, to provide the SCLK output on the auxiliary output, during byte transmissions.

There are four control bits and four status bits in the control register that provide for PSoC device interfacing and synchronization.

The SPIM hardware has no support for driving the Slave Select (SS_) signal. The behavior and use of this signal is application and PSoC device dependent and, if required, must be implemented in firmware.

17.1.11.1 Usability Exceptions

The following are usability exceptions for the SPI Protocol function.

1. The SPIM function may not be chained.
2. The MISO input must be resynchronized at the row inputs.
3. The DR2 (Rx Buffer) register is not writeable.

17.1.11.2 Block Interrupt

The SPIM block has a selection of two interrupt sources: Interrupt on TX Reg Empty (default) or interrupt on SPI Complete. Mode bit 1 in the function register controls the selection. These mode are discussed in detail in “SPIM Timing” on page 360.

If SPI Complete is selected as the block interrupt, the control register must be read in the interrupt routine so that this status bit is cleared; otherwise, no subsequent interrupts are generated.

17.1.12 SPI Slave Function

The SPI Slave (SPIS) offers SPI operating modes 0-3. By default, the MSb of the data byte is shifted out first. An additional option can be set to reverse the direction and shift the data byte out LSb first. (Refer to the timing diagrams for this function on page 363.)

When configured for SPI, DR0 functions as a shift register, with input from the DATA input (MOSI) and output to the primary output F1 (MISO). DR1 is the TX Buffer register and DR2 is the RX Buffer register.

The SPI protocol requires data to be registered at the device input, on the opposite edge of the clock that operates the output shifter. An additional register (RXD), at the input to the DR0 shift register, is implemented for this purpose. This register stores received data for one-half cycle before it is clocked into the shift register.

The SPIS function derives all clocking from the SCLK input (typically an external SPI Master). This means that the master must initiate all transmissions. For example, to read a byte from the SPIS, the master must send a byte.

There are four control bits and four status bits in the control register that provide for PSoC device interfacing and synchronization.

In the SPIS, there is an additional data input, Slave Select (SS_), which is an **active low** signal. SS_ must be asserted to enable the SPIS to receive and transmit. SS_ has two high level functions: 1) To allow for the selection of a given slave in multi-slave environment, and 2) To provide additional clocking for TX data queuing in SPI modes 0 and 1.

SS_ may be controlled from an external pin through a Row Input or can be controlled by way of user firmware.

When SS_ is negated, the SPIS ignores any MOSI/SCLK input from the master. In addition, the SPIS **state machine** is reset, and the MISO output is forced to idle at logic 1. This allows for a wired-AND connection in a multi-slave environment. Note that if High Z output is required when the slave is not selected, this behavior must be implemented in firmware with IO writes to the port drive register.

17.1.12.1 Usability Exceptions

A usability exception for the SPI Slave function.

1. The SPIS function may not be chained.

17.1.12.2 Block Interrupt

The SPIS block has a selection of two interrupt sources: Interrupt on TX Reg Empty (default) or interrupt on SPI Complete (same selection as the SPIM). Mode bit 1 in the function register controls the selection.

If SPI Complete is selected as the block interrupt, the control register must still be read in the interrupt routine so that this status bit is cleared; otherwise, no subsequent interrupts are generated.

17.1.13 Asynchronous Transmitter and Receiver Functions

The Asynchronous Transmitter and Receiver functions are illustrated in Figure 17-6.

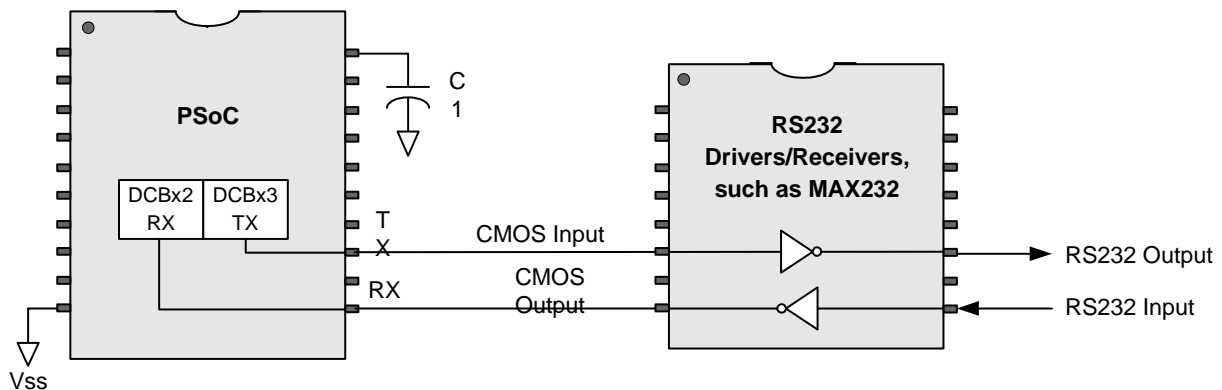

Figure 17-6. Asynchronous Transmitter and Receiver Block Diagram

17.1.13.1 Asynchronous Transmitter Function

In the Transmitter function, DR0 functions as a shift register, with no input and with the TXD serial **data stream** output to the primary output F1. DR1 is a TX Buffer register and DR2 is unused in this configuration. (Refer to the timing diagrams for this function on page 366.)

Unlike SPI, which has no output latency, the TXD output has one cycle of **latency**. This is because a mux at the output must select which bits to shift out: the shift register data, framing bits, **parity**, or mark bits. The output of this mux is registered to remove glitches. When the block is first enabled or when it is idle, a mark bit (logic 1) is output.

The **clock generator** is a free running divide-by-eight circuit. Although dividing the clock is not necessary for the Transmitter function, the Receiver function does require a divide by eight for input sampling. It is also done in the Transmitter function, to allow the TX and RX functions to run off the same baud rate generator.

There are two formats supported: A 10-bit frame size including one start bit, eight data bits, and one **stop bit** or an 11-bit frame size including one start bit, eight data bits, one parity bit, and one stop bit.

The parity generator can be configured to output either even or odd parity on the eight data bits.

A write to the TX Buffer register (DR1) initiates a transmission and an additional byte can be buffered in this register, while transmission is in progress.

An additional feature of the Transmitter function is that a clock, generated with setup and hold time for the data bits only, is output to the auxiliary output. This allows connection to a CRC generator or other digital blocks.

17.1.13.2 Usability Exceptions

The following is a usability exception for the Transmitter function.

1. The Transmitter function may not be chained.

17.1.13.3 Block Interrupt

The Transmit block has a selection of two interrupt sources. Interrupt on TX Reg Empty (default) or interrupt on TX Complete. Mode bit 1 in the function register controls the selection.

If TX Complete is selected as the block interrupt, the control register must still be read in the interrupt routine so that this status bit is cleared; otherwise, no subsequent interrupts are generated.

17.1.13.4 Asynchronous Receiver Function

In the Receiver function, DR0 functions as the serial data shift register with RXD input from the DATA input selection. DR2 is an RX Buffer register and DR1 is unused in this configuration. (Refer to the timing diagrams for this function on page 368.)

The clock generator and START detection are integrated. The clock generator is a divide by eight which, when the system is idle, is held in reset. When a START bit (logic 0) is detected on the RXD input, the reset is negated and a **bit rate (BR)** clock is generated, subsequently sampling the RXD input at the center of the bit time. Every subsequent START bit resynchronizes the clock generator to the incoming bit rate.

There are two formats supported: A 10-bit frame size including one start bit, eight data bits, and one stop bit or an 11-bit frame size including one start bit, eight data bits, one parity bit, and one stop bit.

The received data is an input to the parity generator. It is compared with a received parity bit, if this feature is enabled. The parity generator can be configured to output either even or odd parity on the eight data bits.

After eight bits of data are received, the byte is transferred from the DR0 shifter to the DR2 RX Buffer register.

An additional feature of the Receiver function is that input data (RXD) and the synchronized clock are passed to the primary output and auxiliary output, respectively. This allows connection to a CRC generator or other digital block.

17.1.13.5 Usability Exceptions

The following are usability exceptions for the Asynchronous Receiver function.

1. The RXD input must be resynchronized through the row inputs.
2. DR2 is a read only register.

17.1.13.6 Block Interrupt

The Receiver has one fixed interrupt source, which is the RX Reg Full status.

The RX Buffer register must always be read in the RX interrupt routine, regardless of error status, and so on., so that RX Reg Full status bit is cleared; otherwise, no subsequent interrupts are generated.

17.2 Register Definitions

The following registers are associated with the Digital Blocks and listed in address order. Note that there are two banks of registers associated with the PSoC device. Bank 0 encompasses the user registers (Data and Control registers, and Interrupt Mask registers) for the device and Bank 1 encompasses the Configuration registers for the device. Both are defined below. Refer to the “Bank 0 Registers” on page 149 and the “Bank 1 Registers” on page 253 for a quick reference of PSoC registers in address order.

Each register description that follows has an associated register table showing the bit structure for that register. Depending on how many digital rows your PSoC device has (see the Rows column in the register tables below), only certain bits are accessible to be read or written (refer to the table titled “PSoC Device Characteristics” on page 307). The bits that are grayed out throughout this manual are reserved bits and are not detailed in the register descriptions that follow. Reserved bits should always be written with a value of ‘0’.

The Digital Block registers in this chapter are organized by function, as presented in Table 17-4. To reference timing diagrams associated with the digital block registers, see “Timing Diagrams” on page 355. For a complete table of digital block registers, refer to the “Summary Table of the Digital Registers” on page 308.

Data and Control Registers

The following table summarizes the Data and Control registers, by function type, for the digital blocks.

Table 17-4. Digital Block Data and Control Register Definitions

Function Type	DR0		DR1		DR2		CR0	
	Function	Access	Function	Access	Function	Access	Function	Access
Timer	Down Counter	R*	Period	W	Capture/Compare	RW	Control	RW
Counter	Down Counter	R*	Period	W	Compare	RW	Control	RW
Dead Band	Down Counter	R*	Period	W	N/A	N/A	Control	RW
CRCPRS	LFSR	R*	Polynomial	W	Seed	RW	Control	RW
SPIM	Shifter	N/A	TX Buffer	W	RX Buffer	R	Control/Status	RW**
SPIS	Shifter	N/A	TX Buffer	W	RX Buffer	R	Control/Status	RW**
TXUART	Shifter	N/A	TX Buffer	W	N/A	N/A	Control/Status	RW**
RXUART	Shifter	N/A	N/A	N/A	RX Buffer	R	Control/Status	RW**

LEGEND

* In Timer, Counter, Dead Band, and CRCPRS functions, a read of the DR0 register returns 00h and transfers DR0 to DR2.

* In the Communications functions, control bits are read/write accessible and status bits are read only accessible.

17.2.1 DxBxxDRx Registers

Add.	Name	Rows	Bit 7	Bit 6	Bit 5	Bit 4	Bit 3	Bit 2	Bit 1	Bit 0	Access
0,xxh	DxBxxDR0	4, 3, 2, 1	Data[7:0]								# : 00
0,xxh	DxBxxDR1	4, 3, 2, 1	Data[7:0]								W : 00
0,xxh	DxBxxDR2	4, 3, 2, 1	Data[7:0]								# : 00

LEGEND

Access is bit specific. Refer to the register detail for additional information.

xx An "x" after the comma in the address field indicates that there are multiple instances of the register. For an expanded address listing of these registers, refer to the "Digital Register Summary" on page 308.

The DxBxxDRx Registers are the digital blocks' Data registers.

Bits 7 to 0: Data[7:0]. The Data registers and bits presented in this section encompass the DxBxxDR0, DxBxxDR1, and DxBxxDR2 registers. They are discussed

according to which bank they are located in and then detailed in the tables that follow by function type.

For additional information, refer to the Register Details chapter for the following registers:

- [DxBxxDR0 register on page 153.](#)
- [DxBxxDR1 register on page 154.](#)
- [DxBxxDR2 register on page 155.](#)

17.2.1.1 Timer Register Definitions

There are three 8-bit Data registers and a 3-bit Control register. [Table 17-5](#) explains the meaning of the data registers in the context of timer operation. The Control register is described in section [17.2.2 DxBxxCR0 Register](#).

Note DR2 is not writeable when the Timer is enabled.

Table 17-5. Timer Data Register Descriptions

Name	Function	Description
DR0	Count Value	<p>Not directly readable or writeable.</p> <p>During normal operation, DR0 stores the current count of a synchronous down counter.</p> <p>When disabled, a write to the DR1 period register is also simultaneously loaded into DR0 from the data bus.</p> <p>When disabled, a read of DR0 returns 00h to the data bus and transfers the contents of DR0 to DR2. This transfer only occurs in the addressed block.</p> <p>When enabled, a read of DR0 returns 00h to the data bus and synchronously transfers the contents of DR0 to DR2. It operates simultaneously on the byte addressed and all higher bytes in a multi-block timer.</p> <p>Note that when the hardware capture input is high, the read of DR0 (software capture) will be masked and will not occur. The hardware capture input must be low for a software capture to occur.</p>
DR1	Period	<p>Write only register.</p> <p>Data in this register sets the period of the count. The actual number of clocks counted is Period + 1.</p> <p>In the default one-half cycle Terminal Count mode (TC), a period value of 00h results in the primary output to be the inversion of the input clock. In the optional full cycle TC mode, a period of 00h gives a constant logic high on the primary output.</p> <p>When disabled, a write to this register also transfers the period value directly into DR0.</p> <p>When enabled, if the block frequency is 24 MHz or below, this register may be written to at any time, but the period will only be reloaded into DR0 in the clock following a TC. If the block frequency is 48 MHz, the Terminal Count or Compare Interrupt should be used to synchronize the new period register write; otherwise, the counter could be incorrectly loaded.</p>
DR2	Capture/Compare	<p>Read write register (see Exception below).</p> <p>DR2 has multiple functions in a timer configuration. It is typically used as a capture register, but it also functions as a compare register.</p> <p>When enabled and a capture event occurs, the current count in DR0 is synchronously transferred into DR2.</p> <p>When enabled, the compare output is computed using the compare type (set in the function register mode bits) between DR0 and DR2. The result of the compare is output to the Auxiliary output.</p> <p>When disabled, a read of DR0 transfers the contents of DR0 into DR2 for the addressed block only.</p> <p>Exception: When enabled, DR2 is not writeable.</p>

17.2.1.2 Counter Register Definitions

There are three 8-bit Data registers and a 2-bit Control register. [Table 17-6](#) explains the meaning of these registers in the context of the Counter operation. Note that the descriptions of the registers are dependent on the enable/disable state of the block. This behavior is only related to the enable bit in the Control register, not the data input that provides the counter gate (unless otherwise noted).

Note DR0 may only be read (to transfer DR0 data to DR2) when the block is disabled.

Table 17-6. Counter Data Register Descriptions

Name	Function	Description
DR0	Count Value	Not directly readable or writeable. During normal operation, DR0 stores the current count of a synchronous down counter. When disabled, a write to the DR1 period register is also simultaneously loaded into DR0 from the data bus. When disabled or the data input (counter gate) is low, a read of DR0 returns 00h to the data bus and transfers the contents of DR0 to DR2. This register should not be read when the counter is enabled and counting.
DR1	Period	Write only register. Data in this register sets the period of the count. The actual number of clocks counted is Period + 1. A period of 00h gives a constant logic high on the auxiliary output. When disabled, a write to this register also transfers the period value directly into DR0. When enabled, if the block frequency is 24 MHz or below, this register may be written to at any time, but the period will only be reloaded into DR0 in the clock following a TC. If the block frequency is 48 MHz, the Terminal Count or Compare Interrupt should be used to synchronize the new period register write; otherwise, the counter could be incorrectly loaded.
DR2	Compare	Read write register. DR2 functions as a Compare register. When enabled, the compare output is computed using the compare type (set in the function register mode bits) between DR0 and DR2. The result of the compare is output to the primary output. When disabled or the data input (counter gate) is low, a read of DR0 will transfer the contents of DR0 into DR2. DR2 may be written to when the function is enabled or disabled.

17.2.1.3 Dead Band Register Definitions

There are three 8-bit Data registers and a 3-bit Control register. [Table 17-7](#) explains the meaning of these registers in the context of Dead Band operation.

Note DR0 may only be read (to transfer DR0 data to DR2) when the block is disabled.

Table 17-7. Dead Band Register Descriptions

Name	Function	Description
DR0	Count Value	Not directly readable or writeable. During normal operation, DR0 stores the current count of a synchronous down counter. When disabled, a write to the DR1 period register is also simultaneously loaded into DR0 from the data bus. When disabled, a read of DR0 returns 00h to the data bus and transfers the contents of DR0 to DR2.
DR1	Period	Write only register. Data in this register sets the period of the dead band count. The actual number of clocks counted is Period + 1. The minimum period value is 00h, which sets a dead band time of one clock. When disabled, a write to this register also transfers the period value directly into DR0. When enabled, if the block frequency is 24 MHz or below, this register may be written to at any time, but the period will only be reloaded into DR0 in the clock following a Terminal Count (TC). If the block frequency is 48 MHz, the Terminal Count or Compare Interrupt should be used to synchronize the new period register write; otherwise, the counter could be incorrectly loaded.
DR2	Buffer	When disabled, a read of DR0 transfers the contents of DR0 into DR2.

17.2.1.4 CRCPRS Register Definitions

There are three 8-bit Data registers and one 2-bit Control register. [Table 17-8](#) explains the meaning of these registers in the context of CRCPRS operation. Note that in the CRCPRS function a write to the DR2 Seed register is also loaded simultaneously into DR0.

Table 17-8. CRCPRS Register Descriptions

Name	Function	Description
DR0	LFSR	Not directly readable or writeable. During normal operation, DR0 stores the state of a synchronous Linear Feedback Shift register. When disabled, a write to the DR2 Seed register is also simultaneously loaded into DR0 from the data bus. When disabled, a read of DR0 returns 00h to the data bus and transfers the contents of DR0 to DR2. This register should not be read while the block is enabled.
DR1	Polynomial	Write only register. Data in this register sets the polynomial for the CRC or PRS function. Exception: This register must only be written when the block is disabled.
DR2	Seed/Residue	Read write register. DR2 functions as a Seed and Residue register. When disabled, a write to this register also transfers the seed value directly into DR0. When enabled, DR2 may be written to at any time. The value written will be used in the Compare function. When enabled, the compare output is computed using the compare type (set in the function register mode bits) between DR0 and DR2. The result of the compare is output to the auxiliary output. When disabled, a read of DR0 will transfer the contents of DR0 into DR2. This feature can be used to read out the residue, after a CRC operation is complete.

17.2.1.5 SPI Master Register Definitions

There are three 8-bit Data registers and one 8-bit Control/Status register. [Table 17-9](#) explains the meaning of these registers in the context of SPIM operation.

Table 17-9. SPIM Data Register Descriptions

Name	Function	Description
DR0	Shifter	Not readable or writeable. During normal operation, DR0 implements a Shift register for shifting serial data.
DR1	TX Buffer	Write only register. If no transmission is in progress and this register is written to, the data from this register (DR1) is loaded into the Shift register (DR0), on the following clock edge, and a transmission is initiated. If a transmission is currently in progress, this register serves as a buffer for TX data. This register should only be written to when TX Reg Empty status is set, and this write clears the TX Reg Empty status bit in the Control register. When the data is transferred from this register (DR1) to the Shift register (DR0), then TX Reg Empty status is set.
DR2	RX Buffer	Read only register. When a byte transmission/reception is complete, the data in the shifter (DR0) is transferred into the RX Buffer register and RX Reg Full status in the Control register is set. A read from this register (DR2) clears the RX Reg Full status bit in the Control register.

17.2.1.6 SPI Slave Register Definitions

There are three 8-bit Data registers and one 8-bit Control/Status register. [Table 17-10](#) explains the meaning of these registers in the context of SPIS operation.

Table 17-10. SPIS Data Register Descriptions

Name	Function	Description
DR0	Shifter	Not readable or writeable. During normal operation, DR0 implements a Shift register for shifting serial data.
DR1	TX Buffer	Write only register. This register should only be written to when TX Reg Empty status is set and the write clears the TX Reg Empty status bit in the Control register. When the data is transferred from this register (DR1) to the Shift register (DR0), then TX Reg Empty status is set.
DR2	RX Buffer	Read only register. When a byte transmission/reception is complete, the data in the shifter (DR0) is transferred into the RX Buffer register and RX Reg Full status in the Control (CR0) register is set. A read from this register (DR2) clears the RX Reg Full status bit in the Control register.

17.2.1.7 Transmitter Register Definitions

There are three 8-bit Data registers and one 5-bit Control/Status register. [Table 17-11](#) explains the meaning of these registers in the context of Transmitter operation.

Table 17-11. Transmitter Data Register Descriptions

Name	Function	Description
DR0	Shifter	Not readable or writeable. During normal operation, DR0 implements a shift register for shifting out serial data.
DR1	TX Buffer	Write only register. If no transmission is in progress and this register is written to, subject to the setup time requirement, the data from this register (DR1) is loaded into the Shift register (DR0) on the following clock edge and a transmission is initiated. If a transmission is currently in progress, this register serves as a buffer for TX data. This register should only be written to when TX Reg Empty status is set and this write clears the TX Reg Empty status bit in the Control (CR0) register. When the data is transferred from this register (DR1) to the Shift register (DR0), then TX Reg Empty status is set.
DR2	NA	Not used in this function.

17.2.1.8 Receiver Register Definitions

There are three 8-bit Data registers and one 8-bit Control/Status register. [Table 17-12](#) explains the meaning of these registers in the context of Receiver operation.

Table 17-12. Receiver Data Register Descriptions

Name	Function	Description
DR0	Shifter	Not readable or writeable. During normal operation, DR0 implements a Shift register for shifting in serial data from the RXD input.
DR1	NA	Not used in this function.
DR2	RX Buffer	Read only register. After eight bits of data are received, the contents of the shifter (DR0) is transferred into the RX Buffer register and the RX Reg Full status is set. The RX Reg Full status bit in the Control register is cleared when this register is read.

17.2.2 DxBxxCR0 Register

Add.	Name	Rows	Bit 7	Bit 6	Bit 5	Bit 4	Bit 3	Bit 2	Bit 1	Bit 0	Access
0,xxh	DxBxxCR0	4, 3, 2, 1	Function control/status bits for selected function[6:0]							Enable	# : 00

LEGEND

Access is bit specific. Refer to the register detail for additional information.

xx An "x" after the comma in the address field indicates that there are multiple instances of the register. For an expanded address listing of these registers, refer to the "Digital Register Summary" on page 308.

The DxBxxCR0 Registers are the digital blocks' Control registers.

Bits 7 to 1: Function Control/Status[6:0]. The bits for this register are described by function in Table 17-13. Refer to the "Summary Table of the Digital Registers" on page 308 for a complete description of bit functionality.

Bit 0: Enable. This bit is used to synchronously enable or disable the programmed function.

For additional information, refer to the [DxBxxCR0 \(Timer Control\) register on page 156](#).

Table 17-13. DxBxxCR0 Control Register Descriptions

Function	Description
Timer	There are three bits in the Control (CR0) register: one for enabling the block, one for setting the optional interrupt on capture, and one to select between one-half and a full clock for Terminal Count (TC) output.
Counter	One bit enable only.
Dead Band	There are three bits in the Control (CR0) register: one bit for enabling the block, and two bits to enable and control Dead Band Bit Bang mode. When Bit Bang mode is enabled, the output of this register is substituted for the PWM reference. This register may be toggled by user firmware, to generate PHI1 and PHI2 output clock with the programmed dead time. The options for Bit Bang mode are as follows: 0 Function uses the previous clock primary output as the input reference. 1 Function uses the Bit Bang Clock register as the input reference.
CRCPRS	There are two bits are used to enable operation.
SPIIM	The SPI Control (CR0) register contains both control and status bits. There are four control bits that are read/write: Enable, Clock Phase and Clock Polarity to set the mode, and LSb First which controls bit ordering. There are two read only status bits: Overrun and SPI Complete. There are two additional read only status bits to indicate TX and RX Buffer status.
SPIS	The SPI Control (CR0) register contains both control and status bits. There are four control bits that are read/write: Enable, Clock Phase and Clock Polarity to set the mode, and LSb First which controls bit ordering. There are two read only status bits: Overrun and SPI Complete. There are two additional read only status bits to indicate TX and RX Buffer status.
TXUART	The Transmitter Control (CR0) register contains three control bits and two status bits. The control bits are Enable, Parity Enable, and Parity Type, and have read/write access. The status bits, TX Reg Empty and TX Complete, are read only.
RXUART	The Receiver Control (CR0) register contains both control and status bits. The three control bits are read/write: Enable, Parity Enable, and Parity Type. There are five read only status bits: RX Reg Full, RX Active, Framing Error, Overrun, and Parity Error.

Interrupt Mask Registers

The following registers are the interrupt mask registers for the digital blocks.

17.2.3 INT_MSK2 Register

Add.	Name	Rows	Bit 7	Bit 6	Bit 5	Bit 4	Bit 3	Bit 2	Bit 1	Bit 0	Access
0,DFh	INT_MSK2	4, 3	DCB33	DCB32	DBB31	DBB30	DCB23	DCB22	DBB21	DBB20	RW : 00

The Interrupt Mask Register 2 (INT_MSK2) is used to enable the individual sources' ability to create pending interrupts for digital blocks.

The interrupt mask bits in the INT_MSK2 register are only for PSoC devices with 4 digital rows.

Bit 7: DCB33. Digital communications block interrupt enable for row 3 block 3.

Bit 6: DCB32. Digital communications block interrupt enable for row 3 block 2.

Bit 5: DBB31. Digital basic block interrupt enable for row 3 block 1.

Bit 4: DBB30. Digital basic block interrupt enable for row 3 block 0.

Bit 3: DCB23. Digital communications block interrupt enable for row 2 block 3.

Bit 2: DCB22. Digital communications block interrupt enable for row 2 block 2.

Bit 1: DBB21. Digital basic block interrupt enable for row 2 block 1.

Bit 0: DBB20. Digital basic block interrupt enable for row 2 block 0.

For additional information, refer to the [INT_MSK2 register on page 237](#).

17.2.4 INT_MSK1 Register

Add.	Name	Rows	Bit 7	Bit 6	Bit 5	Bit 4	Bit 3	Bit 2	Bit 1	Bit 0	Access
0,E1h	INT_MSK1	4, 3, 2	DCB13	DCB12	DBB11	DBB10	DCB03	DCB02	DBB01	DBB00	RW : 00
0,E1h	INT_MSK1	1					DCB03	DCB02	DBB01	DBB00	RW : 00

The Interrupt Mask Register 1 (INT_MSK1) is used to enable the individual sources' ability to create pending interrupts for digital blocks.

Depending on the digital row configuration of your PSoC device (see the table titled "[PSoC Device Characteristics](#)" on page 22), some bits may not be available in the INT_MSK1 register.

Bit 7: DCB13. Digital communications block interrupt enable for row 1 block 3.

Bit 6: DCB12. Digital communications block interrupt enable for row 1 block 2.

Bit 5: DBB11. Digital basic block interrupt enable for row 1 block 1.

Bit 4: DBB10. Digital basic block interrupt enable for row 1 block 0.

Bit 3: DCB03. Digital communications block interrupt enable for row 0 block 3.

Bit 2: DCB02. Digital communications block interrupt enable for row 0 block 2.

Bit 1: DBB01. Digital basic block interrupt enable for row 0 block 1.

Bit 0: DBB00. Digital basic block interrupt enable for row 0 block 0.

For additional information, refer to the [INT_MSK1 register on page 240](#).

Configuration Registers

The configuration block contains 3 registers: Function (DxBxxFN), Input (DxBxxIN), and Output (DxBxxOU). The values in these registers should not be changed while the block is enabled. Note that the Digital Block Configuration registers are all located in bank 1 of the PSoC device's memory map.

17.2.5 DxBxxFN Registers

Addr.	Name	Rows	Bit 7	Bit 6	Bit 5	Bit 4	Bit 3	Bit 2	Bit 1	Bit 0	Access
1,xxh	DxBxxFN	4, 3, 2, 1	Data Invert	BCEN	End Single	Mode[1:0]		Function[2:0]			RW : 00

LEGEND

xx An "x" after the comma in the address field indicates that there are multiple instances of the register. For an expanded address listing of these registers, refer to the "Digital Register Summary" on page 308.

The Digital Basic/Communications Type B Block Function Registers (DxBxxFN) contain the primary Mode and Function bits that determine the function of the block.

All bits in these registers are common to all functions, except those specified in Table 17-15.

Bit 7: Data Invert. This bit inverts the selected data input.

Bit 6: BCEN. This bit enables the primary output of the block, to drive the row broadcast block. The BCEN bit is set independently in each block; and therefore, care must be taken to ensure that only one BCEN bit, in a given row, is enabled. However, if any of the blocks in a given row have the BCEN bit set, the input that allows the broadcast net from other rows to drive the given row's broadcast net is disabled (see Figure 16-2 on page 328).

Bit 5: End Single. This bit is used to indicate the last or most significant block in a chainable function. This bit must also be set if the chainable function only consists of a single block.

Bits 4 and 3: Mode[1:0]. The mode bits select the options available for the selected function. These bits should only be changed when the block is disabled.

Bits 2 to 0: Function[2:0]. The function bits configure the block into one of the available block functions (six for the Comm block, four for the Basic block).

For additional information, refer to the DxBxxFN register on page 257.

Table 17-14. DxBxxFN Function Registers

[7]: Data Invert	1 == Invert block's data input 0 == Do not invert block's data input
[6]: BCEN	1 == Enable 0 == Disable
[5]: End Single	1 == Block is not chained or is at the end of a chain 0 == Block is at the start of or in the middle of a chain
[4:3]: Mode	Function specific
[2:0]: Function	000b: Timer 001b: Counter 010b: CRCPRS 011b: Reserved 100b: Dead band for PWM 101b: UART (DCBxx blocks only) 110b: SPI (DCBxx blocks only) 111b: Reserved

Table 17-15. Digital Block Configuration Register Functional Descriptions

Function	Description
Timer	The mode bits in the Timer block control the Interrupt Type and the Compare Type.
Counter	The mode bits in the Counter block control the Interrupt Type and the Compare Type (same as the Timer function).
Dead Band	The mode bits are encoded as the kill type. See the table titled "Dead Band Kill Options" on page 339 for an explanation of Kill options.
CRCPRS	The mode bits are encoded to determine the Compare type.
SPIM	Mode bit 1 selects interrupt type. Mode bit 0 selects master or slave (for SPIM, it is '0').
SPIS	Mode bit 1 selects interrupt type. Mode bit 0 selects master or slave (for SPIS, it is '1').
TXUART	Mode bit 0 selects between Transmitter and Receiver (in this case Mode bit 0 is set to '1' for TX) and Mode bit 1 selects the interrupt type.
RXUART	Mode bit 0 selects between Transmitter and Receiver (in this case Mode bit 0 is set to '0' for RX) and Mode bit 1 selects the interrupt type.

17.2.6 DxBxxIN Registers

Add.	Name	Rows	Bit 7	Bit 6	Bit 5	Bit 4	Bit 3	Bit 2	Bit 1	Bit 0	Access
1,xxh	DxBxxIN	4, 3, 2, 1	Data Input[3:0]				Clock Input[3:0]				RW : 00

LEGEND

xx An "x" after the comma in the address field indicates that there are multiple instances of the register. For an expanded address listing of these registers, refer to the "Digital Register Summary" on page 308.

The Digital Basic/Communications Type B Block Input Registers (DxBxxIN) are used to select the data and clock inputs.

These registers are common to all functional types, except the SPIS. The SPIS is unique in that it has three function inputs and one function output defined. Refer to the DxBxxOU registers.

The input registers are eight bits and consist of two 4-bit fields to control each of the 16-to-1 Clock and Data input muxes. The meaning of these fields depends on the external clock and data connections, which is context specific. See Table 17-16.

Bits 7 to 4: Data Input[3:0]. These bits control the data input.

Bits 3 to 0: Clock Input[3:0]. These bits control the clock input.

Table 17-16. Digital Block Input Definitions

Function	Inputs		
	DATA	CLK	Auxiliary
Timer	Capture	CLK	N/A
Counter	Enable	CLK	N/A
Dead Band	Kill	CLK	Reference *
CRCPRS	Serial Data **	CLK	N/A
SPIM	MISO	CLK	N/A
SPIS	MOSI	SCLK	SS_
Transmitter	N/A	8X Baud CLK	N/A
Receiver	RXD	8X Baud CLK	N/A

* The Dead Band reference input does not use the auxiliary input mux. It is hardwired to be the primary output of the previous block.

** For CRC computation, the input data is a serial data stream synchronized to the clock. For PRS mode, this input should be forced to logic 0.

For additional information, refer to the DxBxxIN register on page 259.

17.2.7 DxBxxOU Registers

Add.	Name	Rows	Bit 7	Bit 6	Bit 5	Bit 4	Bit 3	Bit 2	Bit 1	Bit 0	Access
1,xxh	DxBxxOU	4, 3, 2, 1	AUXCLK		AUXEN	AUX IO Select[1:0]		OUTEN	Output Select[1:0]		RW : 00

LEGEND

xx An "x" after the comma in the address field indicates that there are multiple instances of the register. For an expanded address listing of these registers, refer to the "Digital Register Summary" on page 308.

The Digital Basic/Communications Type B Block Output Registers (DxBxxOU) are used to control the connection of digital block outputs to the available row interconnect and control clock resynchronization.

When the selected function is SPI Slave (SPIS), the AUXEN and AUX IO bits change meaning, and select the input source and control for the Slave Select (SS_) signal.

The Digital Block Output register is common to all functional types, except the SPIS. The SPIS function is unique in that it has three function inputs and one function output defined. When the Aux IO Enable bit is '0', the Aux IO Select bits are used to select one of four inputs from the auxiliary data input mux to drive the SS_ input. Alternatively, when the Aux IO Enable bit is a '1', the SS_ signal is driven directly from the value of the Aux IO Select[0] bit. Thus, the SS_ input can be controlled in firmware, eliminating the need to use an additional GPIO pin for this purpose. Regardless of how the SS_ bit is configured, a SPIS block has the auxiliary row output

drivers forced off; and therefore, the auxiliary output is not available in this block.

The following table enumerates the Primary and Auxiliary outputs that are defined for a given block function. Most functions have two outputs defined (the exception is the SPI Slave, which has only one). One or both of these outputs can optionally be enabled for output. When output, these signals can be routed to other block inputs through row or global interconnect, or output to chip pins.

Table 17-17. Digital Block Output Definitions

Function	Outputs		
	Primary	Auxiliary	Interrupt
Timer	Terminal Count	Compare	Terminal Count or Compare
Counter	Compare	Terminal Count	Terminal Count or Compare
Dead Band	Phase 1	Phase 2	Phase 1
CRCPRS	MSB	Compare	Compare
SPIM	MOSI	SCLK	TX Reg Empty or SPI Complete
SPIS	MISO	N/A **	TX Reg Empty or SPI Complete
Transmitter	TXD	SCLK *	TX Reg Empty or TX Complete
Receiver	RXD	SCLK *	RX Reg Full

* The UART blocks generate an SPI mode 3 style clock that is only active during the data bits of a received or transmitted byte.

** In the SPIS, the field that is used to select the auxiliary output is used to control the auxiliary input to select the SS_.

Bits 7 and 6: AUXCLK. All digital block clock inputs must be resynchronized. The digital blocks have numerous selections for clocking. In addition to the system clocks such as VC1, VC2, and VC3, clocks generated by other digital blocks may be selected through row or global interconnect. To maintain the integrity of block timing, all clocks are resynchronized at the input to the digital block.

The two AUXCLK bits are used to enable the input clock resynchronization. When enabled, the input clock is resynchronized to the selected system clock, which occurs after the 16-to-1 multiplexing. The rules for selecting the value for this register are as follows:

- If the input clock is based on SYSCLK (for example, VC1, VC2, VC3 based on SYSCLK) or the output of other blocks whose clock source is based on SYSCLK, sync to SYSCLK.
- If the input clock is based on SYSCLKX2 (for example, VC3 based on SYSCLKX2) or another digital block clocked by SYSCLKX2, or a SYSCLKX2 based clock, sync to SYSCLKX2.
- If you want to clock the block at 24 MHz (SYSCLK), choose SYSCLK direct in the resynchronized bits (the 16-to-1 input clock selection is ignored).
- If you want to clock the block at 48 MHz (SYSCLKX2), choose SYSCLKX2 as the clock input selection and leave the resynchronized bits in bypass mode.

The following table summarizes the available selections of the AUXCLK bits.

Table 17-18. AUXCLK Bit Selections

Code	Description	Usage
00	Bypass	Use this selection only when SYSCLKX2 (48 MHz) is selected by the 16-to-1 clock multiplexer (see the DxBxxIN register).
01	Resynchronize to SYSCLK (24 MHz)	This is a typical selection. Use this setting for any SYSCLK-based clock: VC1, VC2, VC3 driven by SYSCLK, digital blocks with SYSCLK based source clocks, broadcast bus with source based on SYSCLK, row input and row outputs with source based on SYSCLK.
10	Resynchronize to SYSCLKX2 (48 MHz)	Use this setting for any SYSCLKX2-based clock: VC3 driven by SYSCLKX2, digital blocks with SYSCLKX2 based source clocks, broadcast bus with source based on SYSCLKX2, row input and row outputs with source based on SYSCLKX2.
11	SYSCLK Direct	Use this setting to clock the block directly using SYSCLK. Note that this setting is not strictly related to clock resynchronization: but since SYSCLK cannot resynchronize itself, it allows a direct skew controlled SYSCLK source.

Note Selecting VC1/1 or VC2/1 (when VC1 is 1), or VC3/1 when the input is SYSCLK, or SYSCLKX2 is not allowed.

Bit 5: AUXEN. The AUXEN bit enables the Auxiliary output to be driven onto the selected row output. If the selected function is SPI Slave, the meaning of this bit is different. The SPI Slave does not have a defined Auxiliary output, so this bit is used, in conjunction with the AUX IO Select bits to control the Slave Select input signal (SS_). When this bit is set, the SS_ input is forced active; and therefore, **routing SS_** from an input pin is unnecessary.

Bits 4 and 3: AUX IO Select[1:0]. These two bits select one (out of the 4) row outputs to drive the Auxiliary output onto. In SPI Slave mode, these bits are used in conjunction with the AUXEN bit to control the Slave Select (SS_) signal. In this mode, these two bits are used to select one of four row inputs for use as SS_. If no SS_ is required in a given application, the AUXEN bit can be used to force the SS_ input active; and therefore, routing SS_ in through a Row Input would not be required.

Bit 2: OUTEN. This bit enables the Primary output to be driven onto the selected row output.

Output Select[1:0]. These two bits indicate which of the four row outputs the Primary output will be driven onto.

For additional information, refer to the [DxBxxOU register](#) on page 261.

17.3 Timing Diagrams

The timing diagrams in this section are presented according to their functionality and are in the following order.

- “Timer Timing” on page 355
- “Counter Timing” on page 356
- “Dead Band Timing” on page 357
- “CRCPRS Timing” on page 359
- “SPI Mode Timing” on page 359
- “SPIM Timing” on page 360
- “SPIS Timing” on page 363
- “Transmitter Timing” on page 366
- “Receiver Timing” on page 368

17.3.1 Timer Timing

Enable/Disable Operation. When the block is disabled, the clock is immediately gated low. All outputs are gated low, including the interrupt output. All internal state is reset to its configuration-specific reset state, except for DR0, DR1, and DR2 which are unaffected.

Terminal Count/Compare Operation. In the clock cycle following the count of 00h, the Terminal Count (TC) output is asserted. It is one-half cycle or a full cycle depending on the TC Pulse Width mode, as set in the block Control register. If this block stands alone or is the least significant block in a chain, the Carry Out (CO) signal is also asserted. If the period is set to 00h and the TC Pulse Width mode is one-half cycle, the output is the inversion of the input clock. The Compare (CMP) output will be asserted in the cycle following the compare true and will be negated one cycle after compare false.

Multi-Block Terminal Count/Compare Operation. When timers are chained, the CO signal of a given block becomes the Carry In (CI) of the next most significant block in the chain. In a chained timer, the CO output indicates that block and all lower blocks are at 00h count. The CO is set up to the next positive edge of the clock, to enable the next higher block to count once for every Terminal Count (TC) of all lower blocks.

The terminal count out of a given block becomes the terminal count in of the next least significant block in the chain. The terminal count output indicates that the block and all higher blocks are at 00h count. The terminal count in/terminal count out chaining signals provide a way for the lower blocks to know when the upper blocks are at TC. Reload occurs when all blocks are at TC, which can be determined by CI, terminal count in, and the block zero detect. Example timing for a three block timer is shown in [Figure 17-7](#).

The compare circuit compares registers $DR0 \leq DR2$. (When $Mode[1] = 1$, the comparison is $DR0 < DR2$.)

Each block has an internal compare condition ($DR0$ compared to $DR2$), a chaining signal to the next block called CMPO, and the chaining signal from the previous block

called CMPI. In any given block of a timer, the CMPO is used to generate the auxiliary output (primary output in the counter) with a one cycle clock delay.

CMPO is generated from a combination of the internal compare condition and the CMPI input using the following rules:

1. For any given block, if $DR0 < DR2$, the CMPO condition is unconditionally asserted.
2. For any given block, if $DR0 == DR2$, CMPO is asserted only if the CMPI input to that block is asserted.
3. If the block is a start block, the effective CMPI depends on the compare type. If it is $DR0 \leq DR2$, the effective CMPI input is '1'. If it is $DR0 < DR2$, the effective input is '0'.

Capture Operation. In the timer implementation, a rising edge of the data input or a CPU read of DR0 triggers a synchronous capture event. The result of this is to generate a latch enable to DR2 that loads the current count from DR0 into DR2. The latch enable signal is synchronized in such a way that it is not closing near an edge on which the count is changing.

A limitation is that capture will not work with the block clock of 48 MHz. (A fundamental limitation to Timer Capture operation is the fact the GPIO inputs are currently synchronized to the 24 MHz system clock).

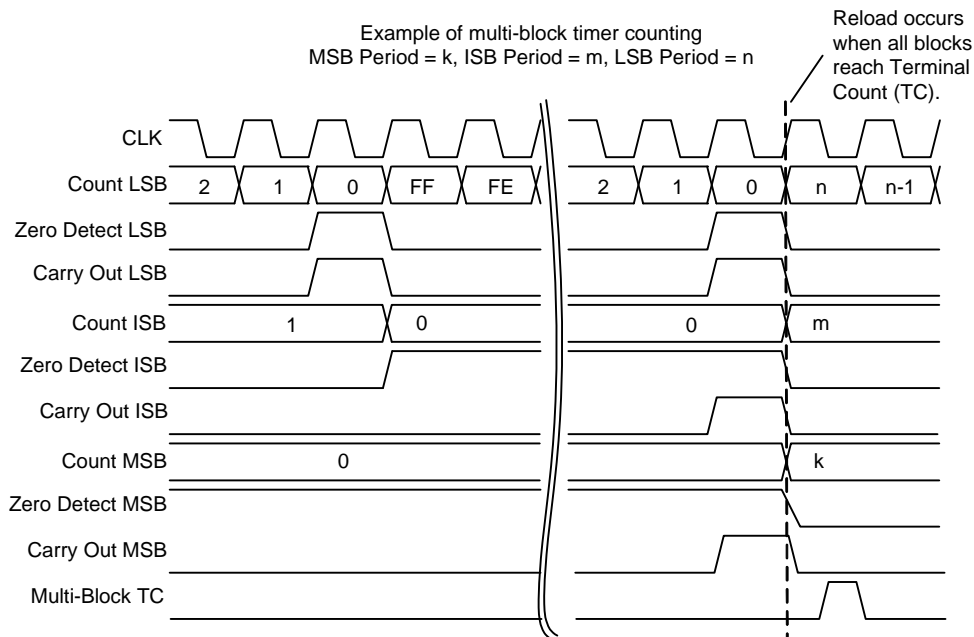

Figure 17-7. Multi-Block Timing

17.3.2 Counter Timing

Enable/Disable Operation. See Timer Enable/Disable Operation (“Timer Function” on page 337).

Terminal Count/Compare Operation. See Timer Terminal Count/Compare Operation (“Timer Function” on page 337).

Multi-Block Operation. See Timer Multi-Block Terminal Count/Compare Operation (“Timer Function” on page 337).

Gate (Enable) Operation. The data input controls the counter enable. The transition on this enable must have at least one 24 MHz cycle of setup time to the block clock. This will be ensured if internal or synchronized external inputs are used.

As shown in Figure 17-8, when the data input is negated (counting is disabled) and the count is 00h, the TC output stays low. When the data input goes high again, the TC occurs on the following input clock. When the block is disabled, the clock is immediately gated low. All internal state is reset, except for DR0, DR1, and DR2, which are unaffected.

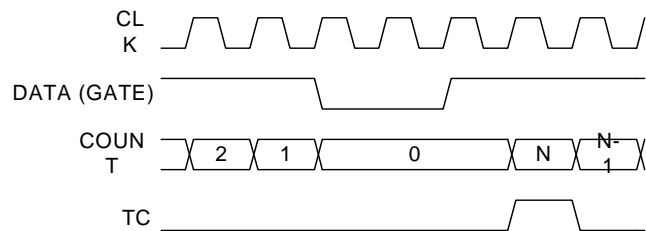

Figure 17-8. Counter Terminal Count Timing with Gate Disable

17.3.3 Dead Band Timing

Enable/Disable Operation. Initially both outputs are low. There are no critical timing requirements for enabling the block because dead band processing does not start until the first incoming positive or negative reference edge. In typical operation, it is recommended that the dead band block be enabled first, then the Pulse Width Modulator (PWM) generator block.

When the block is disabled, the clock is immediately gated low. All outputs are gated low, including the interrupt output. All internal state is reset to its configuration-specific reset state, except for DR0, DR1, and DR2 which are unaffected.

Normal Operation. Figure 17-9 shows typical dead band timing. The incoming reference edge can occur up to one 24 MHz system clock before the edge of the block clock. On the edge of the block clock, the currently asserted output is negated and the dead band counter is enabled. After Period + 1 clocks, the phase associated with the current state of the PWM reference is asserted (Reference High = Phase 1, Reference Low = Phase 2). The minimum dead time occurs with a period value of 00h and that dead time is one clock cycle.

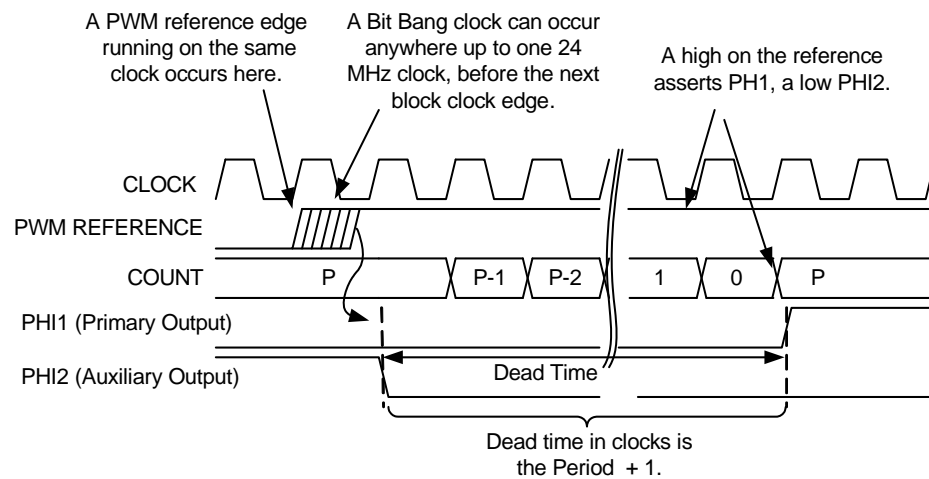

Figure 17-9. Basic Dead Band Timing

17.3.3.1 Changing the PWM Duty Cycle

Under normal circumstances, the dead band period is less than the minimum PWM high or low time. As an example, consider Figure 17-10 where the low of the PWM is four clocks, the dead band period is two clocks, and the high time of the PHI2 is two clocks.

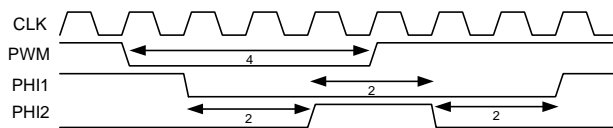

Figure 17-10. DB High Time is PWM Width Minus DB Period

Figure 17-11 illustrates the reduction of the width of the PWM low time by one clock (to three clocks). The dead band period remains the same, but the high time for PHI2 is reduced by one clock (to one clock). Of course the opposite phase, PHI1, increases in length by one clock.

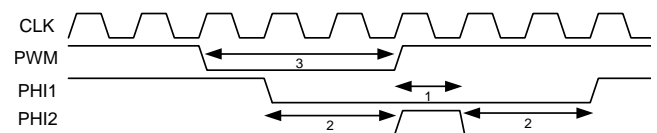

Figure 17-11. DB High Time is Reduced as PWM Width is Reduced

If the width of the PWM low time is reduced to a point where it is equal to the dead band period, the corresponding phase, PHI2, disappears altogether. Note that after the rising edge of the PWM, the opposite phase still has the programmed dead band. Figure 17-12 shows an example where the dead band period is two and the PWM width is two. In this case, the high time of PHI2 is zero clocks. Note that the Phase 1 dead band time is still two clocks.

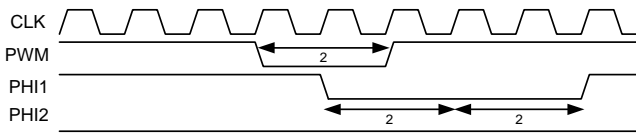

Figure 17-12. PWM Width Equal to Dead Band Period

In the case where the dead band period is greater than the high or low of the PWM reference, the output of the associated phase will not be asserted high.

17.3.3.2 Kill Operation

It is assumed that the KILL input will not be synchronized at the row input. (This is not a requirement; however, if synchronized, the KILL operation will have up to two 24 MHz clock cycles latency which is undesirable.) To support the restart modes, the negation of KILL is internally (in the block) synchronized to the 24 MHz system clock.

There are three KILL modes supported. In all cases, the KILL signal asynchronously forces the outputs to logic 0. The differences in the modes come from how dead band processing is restarted.

1. **Synchronous Restart Mode:** When KILL is asserted high, the internal state is held in reset and the initial dead band period is reloaded into the counter. While KILL is held high, incoming PWM reference edges are ignored. When KILL is negated, the next incoming PWM reference edge restarts dead band processing. See Figure 17-13.
2. **Asynchronous Restart Mode:** When KILL is asserted high, the internal state is not affected. When KILL is negated, the outputs are restored, subject to a minimum disable time between one-half and one and one-half clock cycle. See Figure 17-14.
3. **Disable Mode:** There is no specific timing associated with Disable mode. The block is disabled and the user must re-enable the function in firmware to continue processing.

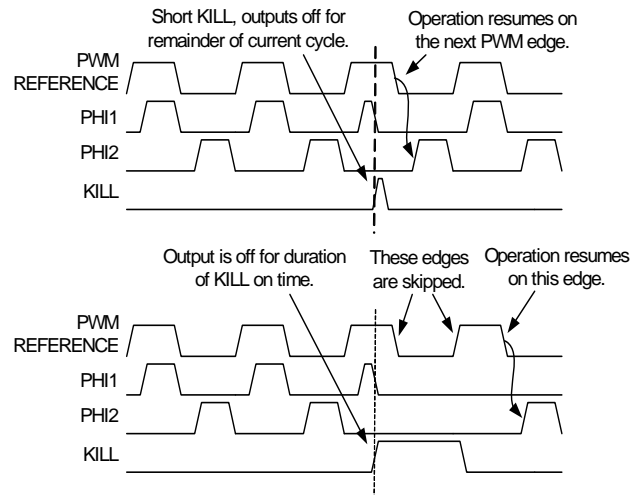

Figure 17-13. Synchronous Restart KILL Mode

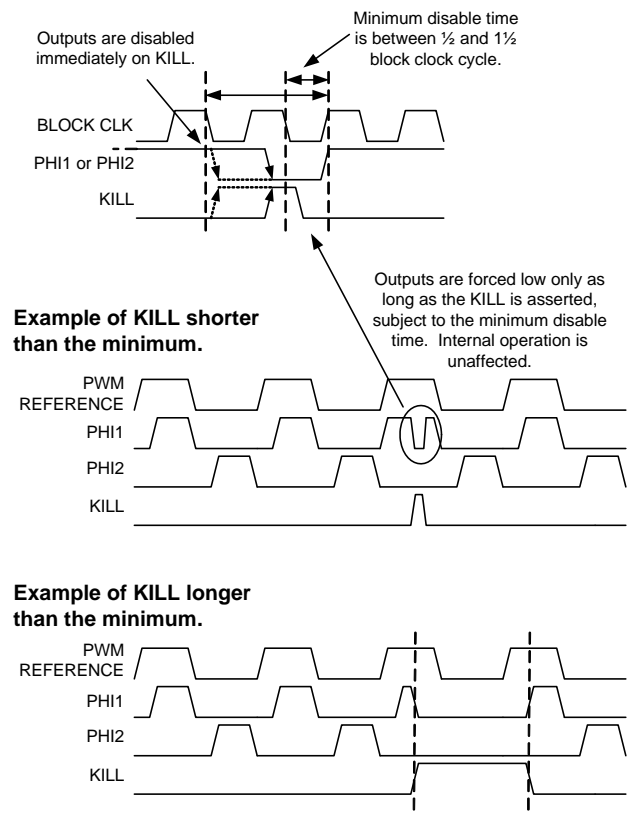

Figure 17-14. Asynchronous Restart Kill Mode

17.3.4 CRCPRS Timing

Enable/Disable Operation. Same as Timer Enable/Disable Operation (“Timer Timing” on page 355)

When the block is disabled, the clock is immediately gated low. All outputs are gated low, including the interrupt output. All internal state is reset to its configuration-specific reset state, except for DR0, DR1, and DR2 which are unaffected.

17.3.5 SPI Mode Timing

Figure 17-15 shows the SPI modes, which are typically defined as 0,1, 2, or 3. These mode numbers are an encoding of two control bits: Clock Phase and Clock Polarity.

Clock phase indicates the relationship of the clock to the data. When the clock phase is '0', it means that the data is registered as an input on the leading edge of the clock and the next data is output on the trailing edge of the clock. When the clock phase is '1', it means that the next data is output on the leading edge of the clock and that data is registered as an input on the trailing edge of the clock.

Clock polarity controls clock inversion. When clock polarity is set to '1', the clock *idle state* is high.

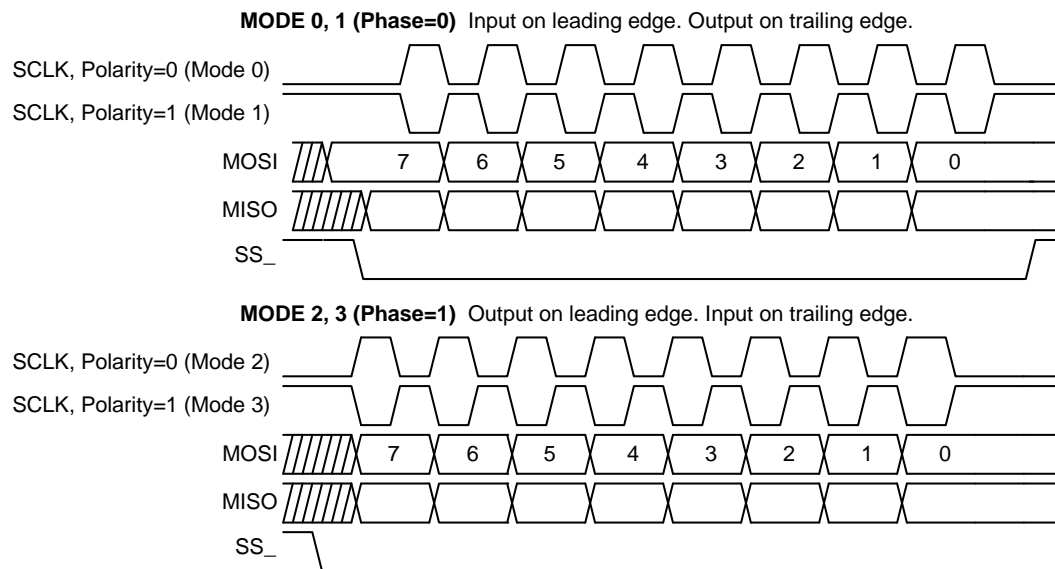

Figure 17-15. SPI Mode Timing

17.3.6 SPIM Timing

Enable/Disable Operation. As soon as the block is configured for SPIM, the primary output is the MSb or LSb of the Shift register, depending on the LSb First configuration in bit 7 of the Control register. The auxiliary output is '1' or '0' depending on the idle clock state of the SPI mode. This is the idle state.

When the SPIM is enabled, the internal reset is released on the divide-by-2 flip-flop and on the next positive edge of the selected input clock. This 1-bit divider transitions to a '1' and remains free-running thereafter.

When the block is disabled, the SCLK and MOSI outputs revert to their idle state. All internal state is reset (including CR0 status) to its configuration-specific reset state, except for DR0, DR1, and DR2 which are unaffected.

Normal Operation. Typical timing for a SPIM transfer is shown in Figure 17-16 and Figure 17-17. The user initially writes a byte to transmit when TX Reg Empty status is true. If no transmission is currently in progress, the data is loaded into the shifter and the transmission is initiated. The TX Reg Empty status is asserted again and the user is allowed to write the next byte to be transmitted to the TX Buffer register. After the last bit is output, if TX Buffer data is available with one-half clock setup time to the next clock, a new byte transmission will be initiated. A SPIM block receives a byte at the same time that it sends one. The SPI Complete or RX Reg Full can be used to determine when the input byte has been received.

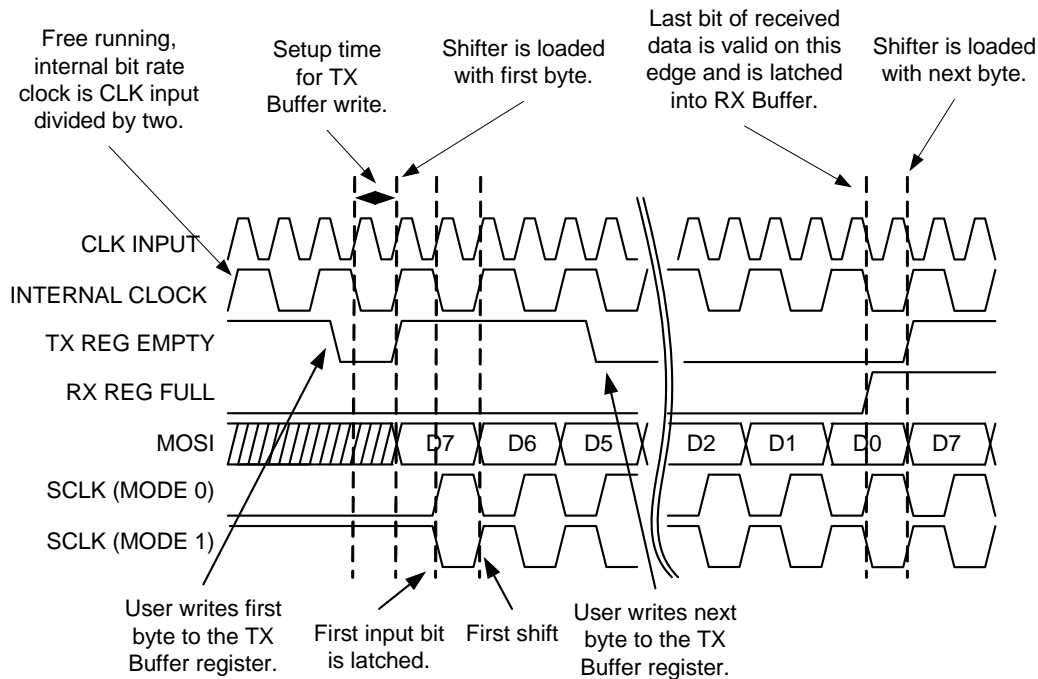

Figure 17-16. Typical SPIM Timing in Mode 0 and 1

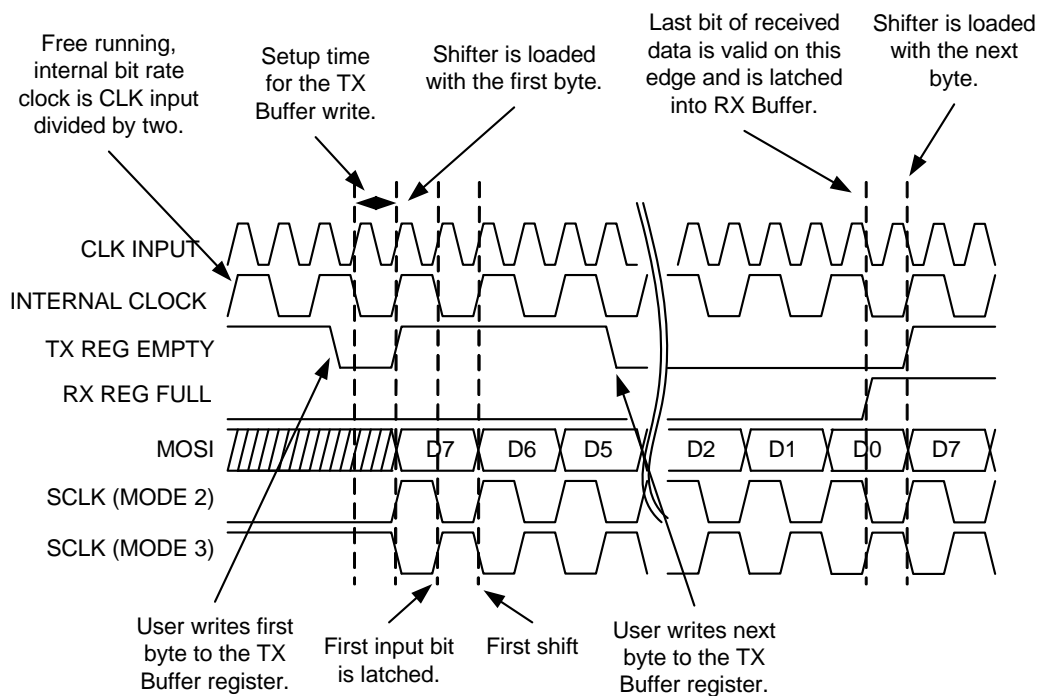

Figure 17-17. Typical SPI Timing in Mode 2 and 3

Status Generation and Interrupts. There are four status bits in an SPI Block: TX Reg Empty, RX Reg Full, SPI Complete, and Overrun.

TX Reg Empty indicates that a new byte can be written to the TX Buffer register. When the block is enabled, this status bit is immediately asserted. This status bit is cleared when the user writes a byte of data to the TX Buffer register. TX Reg Empty is a control input to the state machine and, if a transmission is not already in progress, the assertion of this control signal initiates one. This is the default SPI block interrupt. However, an initial interrupt is not generated when the block is enabled. The user must write a byte to the TX Buffer register and that byte must be loaded into the shifter before interrupts generated from the TX Reg Empty status bit are enabled.

RX Reg Full is asserted on the edge that captures the eighth bit of receive data. This status bit is cleared when the user reads the RX Buffer register (DR2).

SPI Complete is an optional interrupt and is generated when eight bits of data and clock have been sent. In modes 0 and 1, this occurs one-half cycle after RX Reg Full is set; because in these modes, data is latched on the leading edge of the clock and there is an additional one-half cycle remaining to complete that clock. In modes 2 and 3, this occurs at the same edge that the receive data is latched. This signal may be used to read the received byte or it may be used by the SPI to disable the block after data transmission is complete.

Overrun status is set, if RX Reg Full is still asserted from a previous byte when a new byte is about to be loaded into the RX Buffer register. Because the RX Buffer register is implemented as a latch, Overrun status is set one-half bit clock before RX Reg Full status.

See [Figure 17-18](#) and [Figure 17-19](#) for status timing relationships.

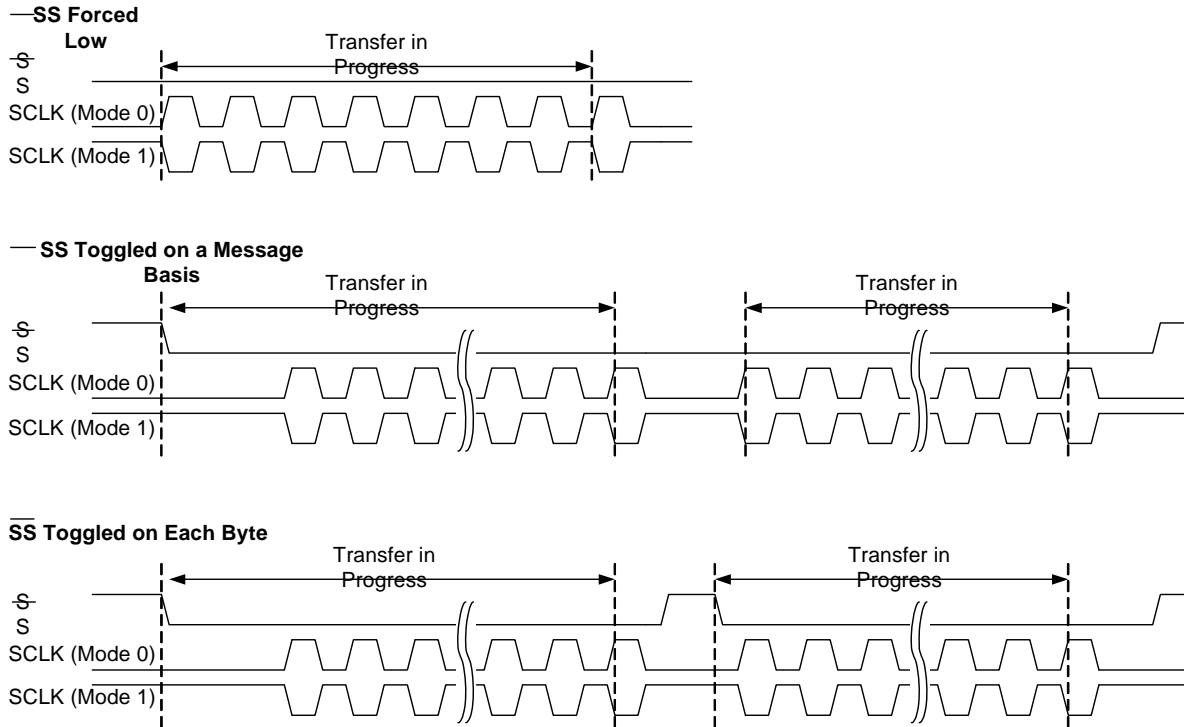

Figure 17-18. SPI Status Timing for Modes 0 and 1

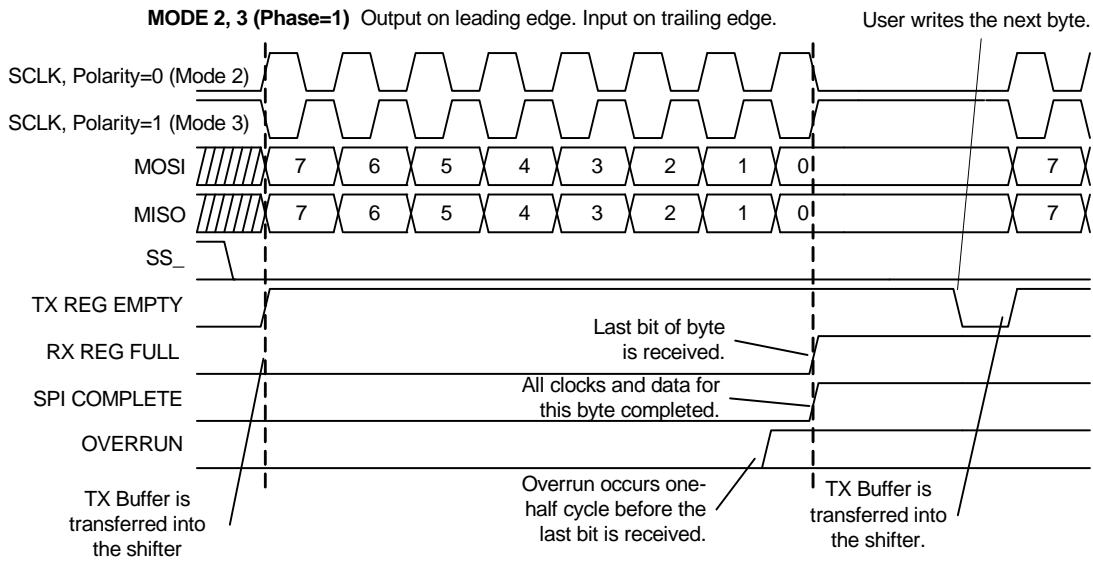

Figure 17-19. SPI Status Timing for Modes 2 and 3

17.3.7 SPIS Timing

Enable/Disable Operation. As soon as the block is configured for SPI Slave and before enabling, the MISO output is set to idle at logic 1. Both the enable bit must be set and the SS_ asserted (either driven externally or forced by firmware programming) for the block to output data. When enabled, the primary output is the MSb or LSb of the shift register, depending on the LSb First configuration in bit 7 of the Control register. The auxiliary output of the SPIS is always forced into tri-state.

Since the SPIS has no internal clock, it must be enabled with setup time to any external master supplying the clock. Setup time is also required for a TX Buffer register write, before the first edge of the clock or the first falling edge of SS_, depending on the mode. This setup time must be assured through the protocol and an understanding of the timing between the master and slave in a system.

When the block is disabled, the MISO output reverts to its idle '1' state. All internal state is reset (including CR0 status) to its configuration-specific reset state, except for DR0, DR1, and DR2 which are unaffected.

Normal Operation. Typical timing for a SPIS transfer is shown in Figure 17-20 and Figure 17-21. If the SPIS is primarily being used as a receiver, the RX Reg Full (polling only) or SPI Complete (polling or interrupt) status may be used to determine when a byte has been received. In this way, the SPIS operates identically with the SPIM. However, there are two main areas in which the SPIS operates differently: 1) SPIS behavior related to the SS_ signal, and 2) TX data queuing (loading the TX Buffer register).

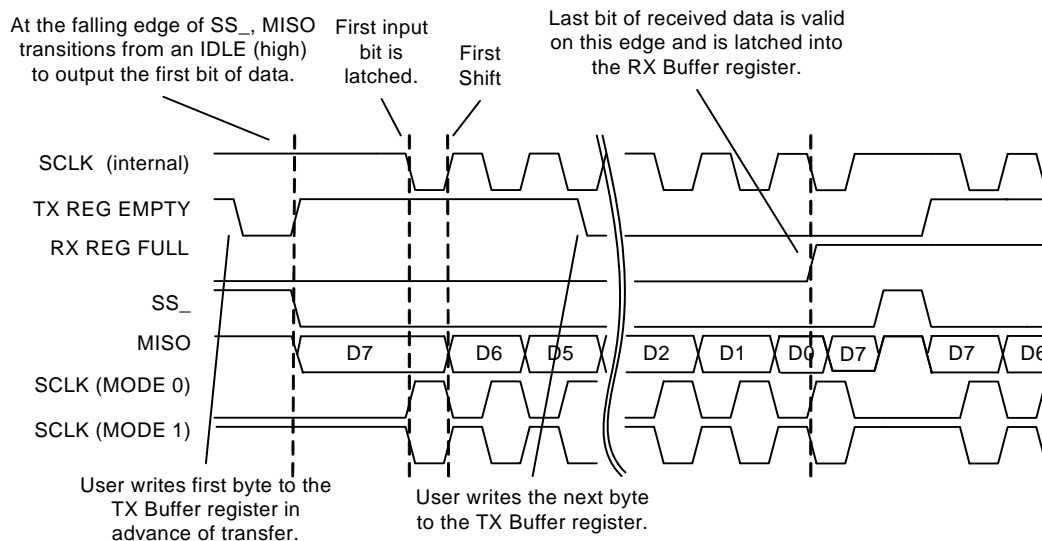

Figure 17-20. Typical SPIS Timing in Modes 0 and 1

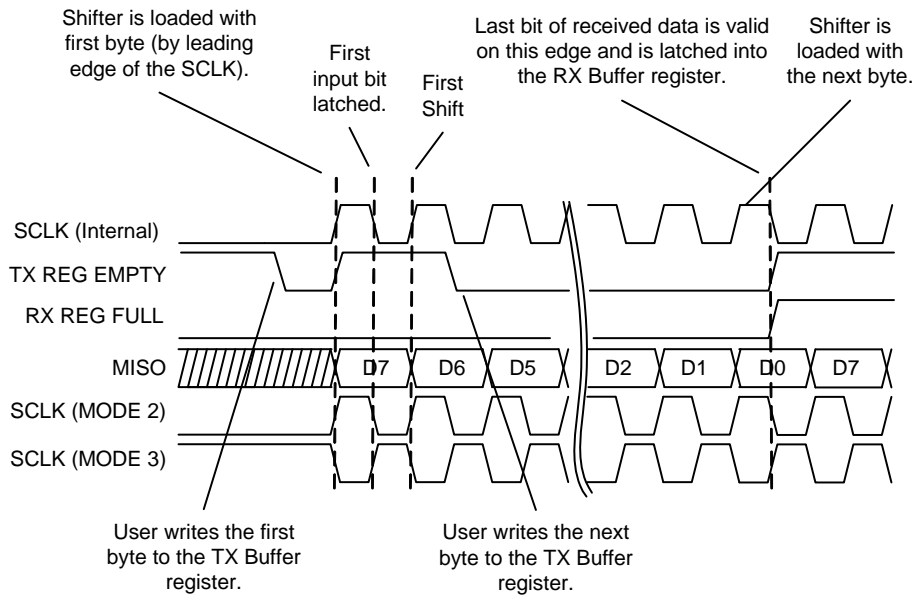

Figure 17-21. Typical SPIS Timing in Modes 2 and 3

Slave Select (SS_, active low). Slave Select must be asserted to enable the SPIS for receive and transmit. There are two ways to do this:

1. Drive the auxiliary input from a pin (selected by the Aux IO Select bits in the output register). This gives the SPI master control of the slave selection in a multi-slave environment.
2. SS_ may be controlled in firmware with register writes to the output register. When Aux IO Enable = 1, Aux IO Select bit 0 becomes the SS_ input. This allows the user to save an input pin in single slave environments.

When SS_ is negated (whether from an external or internal source), the SPIS state machine is reset and the MISO output is forced to idle at logic 1. In addition, the SPIS will ignore any incoming MOSI/SCLK input from the master.

Status Generation and Interrupts. There are four status bits in the SPIS Block: TX Reg Empty, RX Reg Full, SPI Complete, and Overrun. The timing of these status bits are identical to the SPIM, with the exception of TX Reg Empty which is covered in the section on TX data queuing.

Status Clear On Read. Refer to the same subsection in “SPIM Timing” on page 360.

TX Data Queuing. Most SPI applications call for data to be sent back from the slave to the master. Writing firmware to accomplish this requires an understanding of how the Shift register is loaded from the TX Buffer register.

All modes use the following mechanism: 1) If there is no transfer in progress, 2) if the shifter is empty, and 3) if data is

available in the TX Buffer register, the byte is loaded into the shifter.

The only difference between the modes is that the definition of “transfer in progress” is slightly different between modes 0 and 1, and modes 2 and 3.

Figure 17-22 illustrates TX data loading in modes 0 and 1. A transfer in progress is defined to be from the falling edge of SS_ to the point at which the RX Buffer register is loaded with the received byte. This means that in order to send a byte in the next transfer, it must be loaded into the TX Buffer register before the falling edge of SS_. This ensures a minimum setup time for the first bit, since the leading edge of the first SCLK must latch in the received data. If SS_ is not toggled between each byte or is forced low through the configuration register, the leading edge of SCLK is used to define the start of transfer. However, in this case, the user must provide the required setup time (one-half clock minimum before the leading edge), with a knowledge of system latencies and response times.

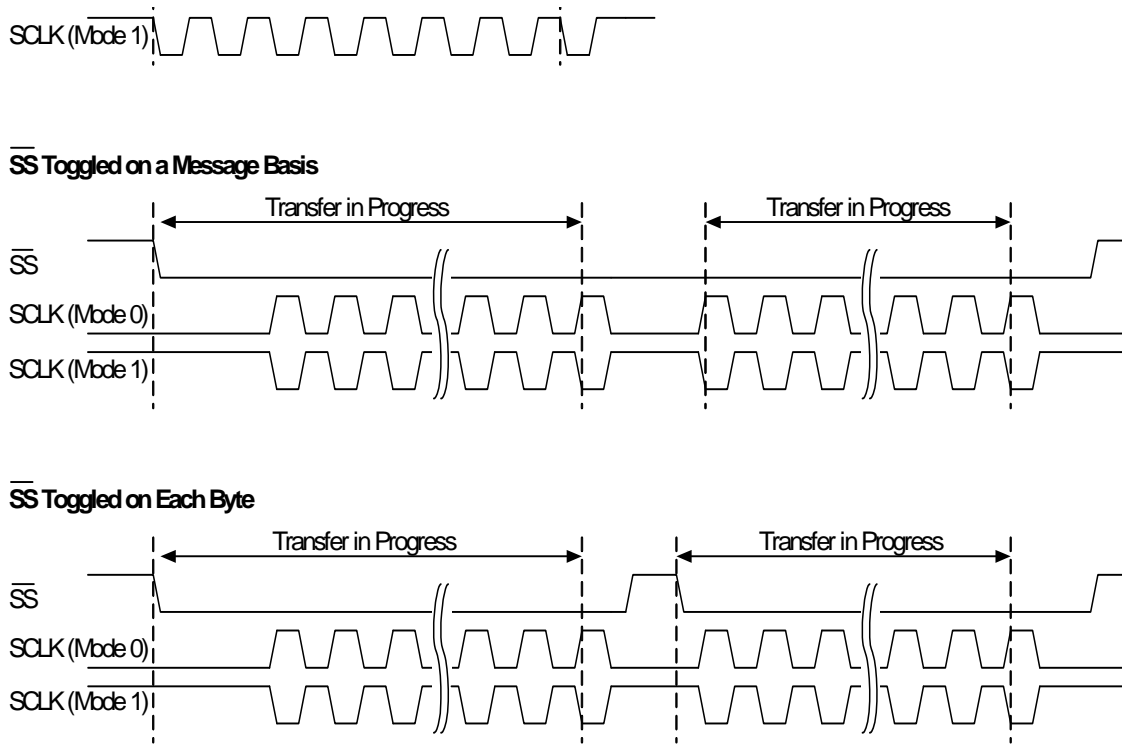

Figure 17-22. Mode 0 and 1 Transfer in Progress

Figure 17-23 illustrates TX data loading in modes 2 and 3. In this case, there is no dependence on \overline{SS} and a transfer in progress is defined to be from the leading edge of the first SCLK to the point at which the RX Buffer register is loaded with the received byte. Loading the shifter by the leading edge of the clock has the effect of providing the required one-half clock setup time, as the data is latched into the receiver on the trailing edge of the SCLK in these modes.

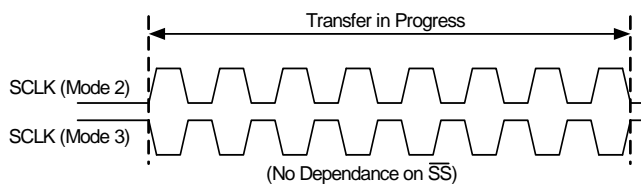

Figure 17-23. Mode 2 and 3 Transfer in Progress

17.3.8 Transmitter Timing

Enable/Disable Operation. As soon as the block is configured for the Transmitter and before enabling, the primary output is set to idle at logic 1, the mark state. The output will remain '1' until the block is enabled and a transmission is initiated. The auxiliary output will also idle to '1', which is the idle state of the associated SPI mode 3 clock.

When the Transmitter is enabled, the internal reset is released on the divide-by-eight clock generator circuit. On the next positive edge of the selected input clock, this 3-bit up counter circuit, which generates the bit clock with the MSb, starts counting up from 00h, and is free-running thereafter.

When the block is disabled, the clock is immediately gated low. All internal state is reset (including CR0 status) to its configuration-specific reset state, except for DR0, DR1, and DR2 which are unaffected.

Transmit Operation. Transmission is initiated with a write to the TX Buffer register (DR1). The CPU write to this register is required to have one-half bit clock setup time for the data, to be recognized at the next positive internal bit clock edge. As shown in Figure 17-24, once the setup time is met, there is one clock of latency until the data is loaded into the shifter and the START bit is generated to the TXD (primary) output.

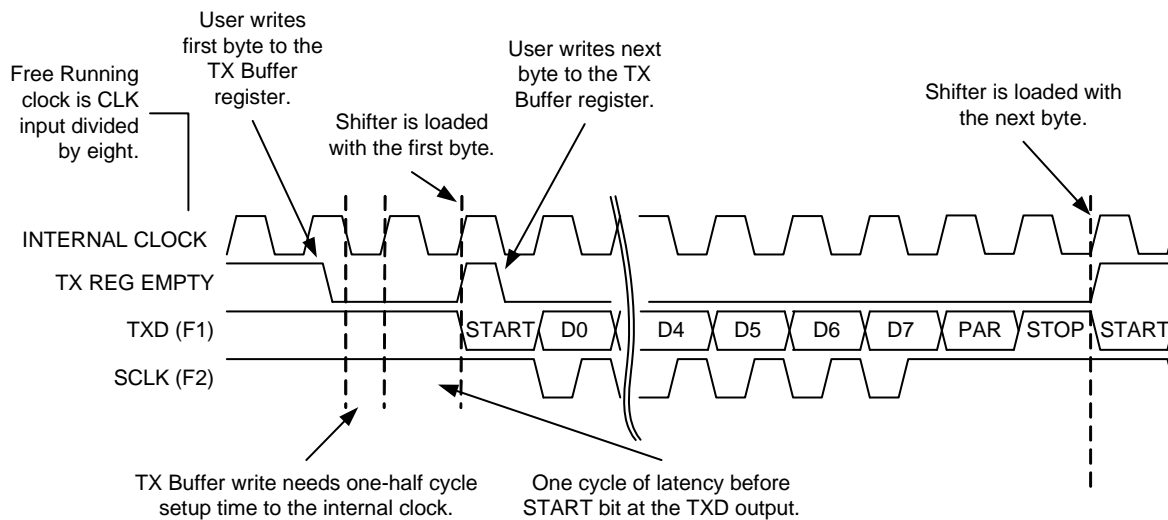

Figure 17-24. Typical Transmitter Timing

Figure 17-25 shows a detail of the Tx Buffer load timing. The data bits are shifted out on each of the subsequent clocks. Following the eighth bit, if parity is enabled, the parity bit is sent to the output. Finally, the STOP bit is multiplexed into the data stream. With one-half cycle setup to the next clock, if new data is available from the TX Buffer register, the next byte is loaded on the following clock edge and the process is repeated. If no data is available, a mark (logic 1) is output.

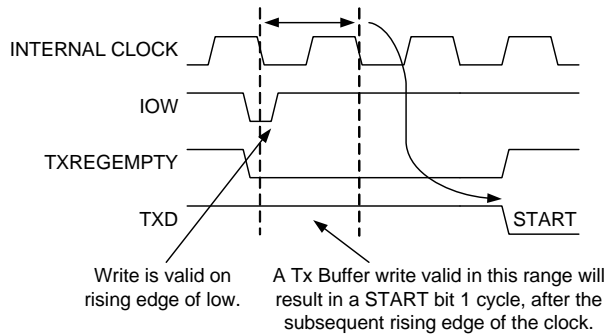

Figure 17-25. Tx Buffer Load Timing

The SCLK (auxiliary) output has a SPI mode 3 clock associated with the data bits (for the mode 3 timing see Figure 17-15). During the mark (idle) and framing bits the SCLK output is high.

Status Generation. There are two status bits in the Transmitter CR0 register: TX Reg Empty and TX Complete.

TX Reg Empty indicates that a new byte can be written to the TX Buffer register. When the block is enabled, this status bit is immediately asserted. This status bit is cleared when the user writes a byte of data to the TX Buffer register and set when the data byte in the TX Buffer register is transferred into the shifter. If a transmission is not already in progress, the assertion of this signal initiates one subject to the timing.

The default interrupt in the Transmitter is tied to TX Reg Empty. However, an initial interrupt is not generated when the block is enabled. The user must write an initial byte to the TX Buffer register. That byte must be transferred into the shifter, before interrupts generated from the TX Reg Empty status bit are enabled. This prevents an interrupt from occurring immediately on block enable.

TX Complete is an optional interrupt and is generated when all bits of data and framing bits have been sent. It is cleared on a read of the CR0 register. This signal may be used to determine when it is safe to disable the block after data transmission is complete. In an interrupt driven Transmitter application, if interrupt on TX Complete is selected, the status must be cleared on every interrupt; otherwise, the status will remain high and no subsequent interrupts are logged. See Figure 17-26 for timing relationships.

Status Clear On Read. Refer to the SPIM subsection in “SPIM Timing” on page 360.

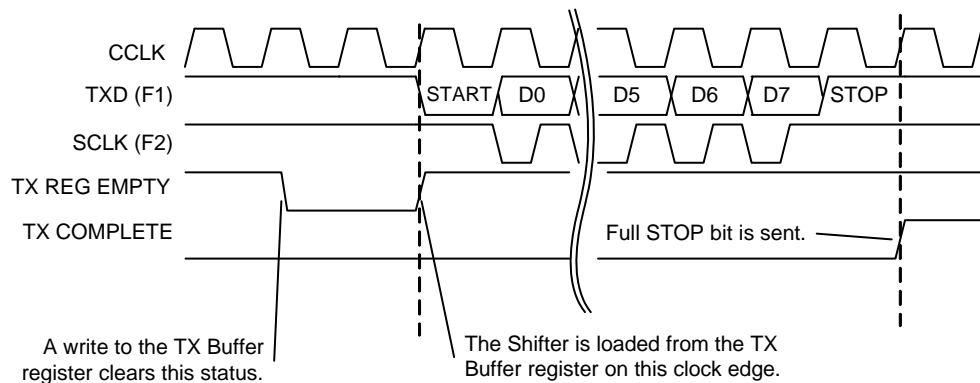

Figure 17-26. Status Timing for the Transmitter

17.3.9 Receiver Timing

Enable/Disable Operation. As soon as the block is configured for Receiver and before enabling, the primary output is connected to the data input (RXD). This output will continue to follow the input, regardless of enable state. The auxiliary output will idle to '1', which is the idle state of the associated SPI mode 3 clock.

When the Receiver is enabled, the internal clock generator is held in reset until a START bit is detected on the input. The block must be enabled with a setup time to the first START bit input.

When the block is disabled, the clock is immediately gated low. All internal state is reset (including CR0 status) to its configuration-specific reset state, except for DR0, DR1, and DR2 which are unaffected.

Receive Operation. A clock, which must be eight times the desired baud rate, is selected as the CLK input. This clock is an input to the RX block clock divider. When the receiver is idle, the clock divider is held in reset. As shown in Figure 17-27, reception is initiated when a START bit (logic 0) is detected on the RXD input. When this occurs, the reset is negated to the clock divider and the 3-bit counter starts an

up-count. The block clock is derived from the MSb of this counter (corresponding to a count of four), which serves to sample each incoming bit at the nominal center point. This clock also sequences the state machine at the specified bit rate.

The sampled data is registered into an input flip-flop. This flip-flop feeds the DR0 Shift register. Only data bits are shifted into the Shift register.

At the STOP sample point, the block is immediately (within one cycle of the 24 MHz system clock) set back into an idle state. In this way, the clock generation circuit can immediately enable the search for the next START bit, thereby re-synchronizing the bit clock with the incoming bit rate on every new data byte reception. The RX Reg Full status bit, as well as error status, is also set at the STOP sample point.

To facilitate connection to other digital blocks, the RXD input is passed directly to the RXDOUT (primary) output. The SCLK (auxiliary) output has an SPI mode 3 clock associated with the data bits (for mode 3 timing see Figure 17-27). During the mark (idle) and framing bits, the SCLK output is high.

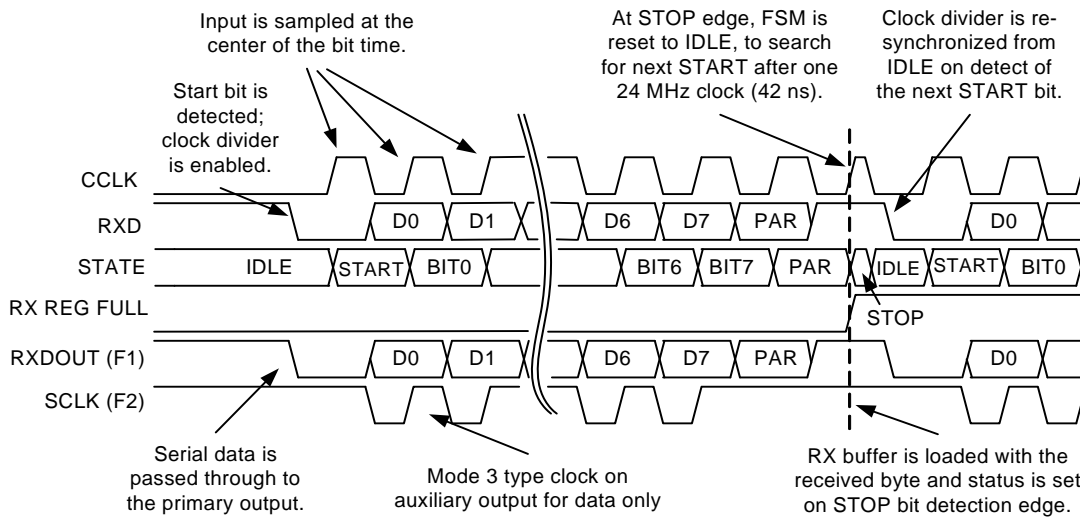

Figure 17-27. Receiver Operation

Clock Generation and Start Detection. The input clock selection is a free running, eight times over-sampling clock. This clock is used by the clock divider circuit to generate the block clock at the bit rate. As shown in Figure 17-28, the clock block is derived from the MSb of a 3-bit counter, giving a sample point as near to the center of the bit time as possible. This block clock is used to clock all internal circuits.

Since the RXD bit rate is asynchronous to the block bit clock, these clocks must be continually re-aligned. This is accomplished with the START bit detection.

When in IDLE state, the clock divider is held in reset. On START (when the input RXD transitions are detected as a

logic 0), the reset is negated and the divider is enabled to count at the eight times rate. If the RXD input is still logic 0 after three samples of the input clock, the status RXACTIVE is asserted, which initiates a reception. If this sample of the RXD line is a logic 1, the input '0' transition was assumed to be a false start and the Receiver remains in the idle state.

As shown in Figure 17-28, the internal bit clock (CCLK) is running slower than the external TX bit clock and the STOP bit is sampled later than the actual center point. After the STOP bit is sampled, the 24 MHz reset pulse forces the Receiver back to an idle state. In this state, the next START bit search is initiated, resynchronizing the RX bit clock to the TX bit clock.

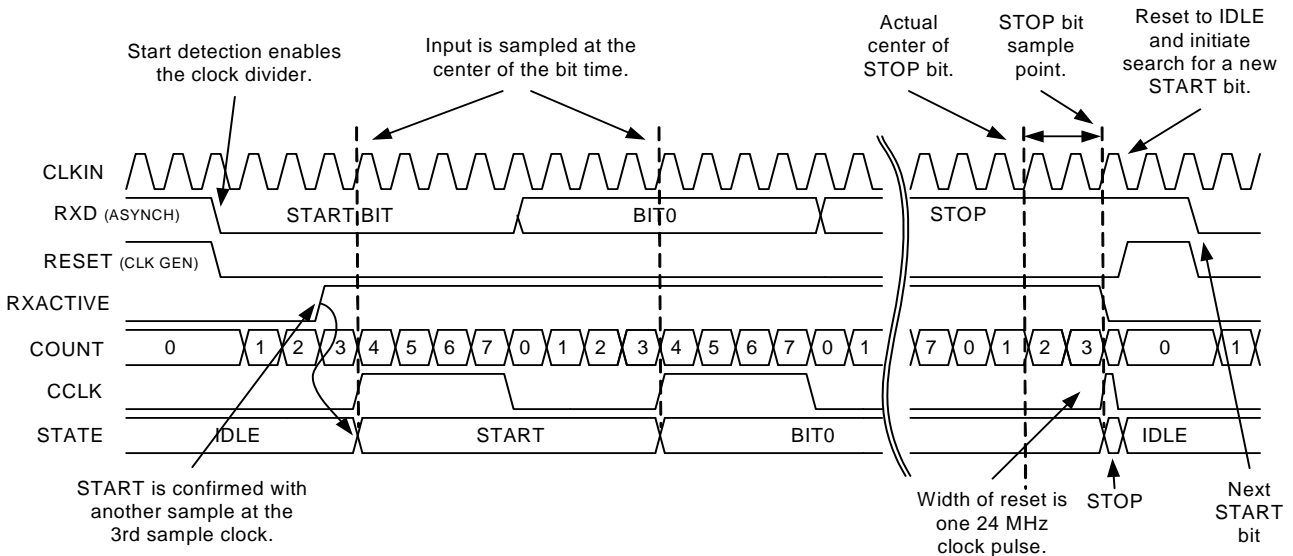

Figure 17-28. Clock Generation and Start Detection

This resynchronization process (forcing the state back to idle) occurs regardless of the value of the STOP bit sample. It is important to reset as soon as possible, so that maximum performance can be achieved. Figure 17-29 shows an example where the RX block clock bit rate is slower than the external TX bit rate. The sample point shifts to successively later times. In the extreme case shown, the RX samples the STOP bit at the trailing edge. In this case, the receiver has counted 9.5 bit times, while the transmitter has counted 10 bit times. Therefore, for a 10-bit message, the maximum theoretical clock offset, for the message to be received correctly, is represented by one-half bit time or five percent. If the RX and TX clocks exceed this offset, a logic 0 may be sampled for the STOP bit. In this case, the Framing Error status is set.

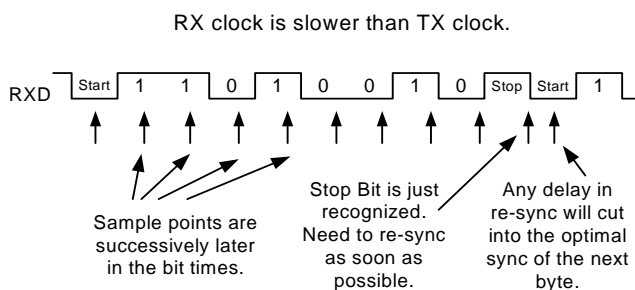

Figure 17-29. Example RX Re-Synchronization

This theoretical maximum will be degraded by the resynchronization time, which is fixed at approximately 42 ns. In a typical 115.2 Kbaud example, the bit time is 8.70 μ s. In this case the new maximum offset is:

$$((4.35 \text{ ms} - 42 \text{ ns}) / 4.35 \text{ ms}) \times 5\% \text{ or } 4.95\%$$

At slower baud rates, this value gets closer to the theoretical maximum of five percent.

Status Generation. There are five status bits in a Receiver block: RX Reg Full, RX Active, Framing Error, Overrun, and Parity Error. All status bits, except RX Active and Overrun, are set synchronously on the STOP bit sample point.

RX Reg Full indicates a byte has been received and transferred into the RX Buffer register. This status bit is cleared when the user reads the RX Buffer register (DR2). The setting of this bit is synchronized to the STOP sample point. This is the earliest point at which the Framing Error status can be set; and therefore, error status is defined to be valid when RX Reg Full is set.

RX Active can be polled to determine if a reception is in progress. This bit is set on START detection and cleared on STOP detection. This bit is not **sticky** and there is no way for the user to clear it.

Framing Error status indicates that the STOP bit associated with a given byte was not received correctly (expecting a '1', but received a '0'). This will typically occur when the difference between the baud rates of the transmitter and receiver is greater than the maximum allowed.

Overrun occurs when there is a received data byte in the RX Buffer register and a new byte is loaded into the RX Buffer register, before the user has had a chance to read the previous one. Because the RX Buffer register is actually a latch, Overrun status is set one-half cycle before RX Reg Full. This means that although the new data is not available, the previous data has been overwritten because the latch was opened.

Parity Error status indicates that resulting parity calculation on the received byte does not match the value of the parity bit that was transmitted. This status is set on the sample point of the STOP signal.

Status Clear On Read. Refer to the SPIM subsection in “SPIM Timing” on page 360.

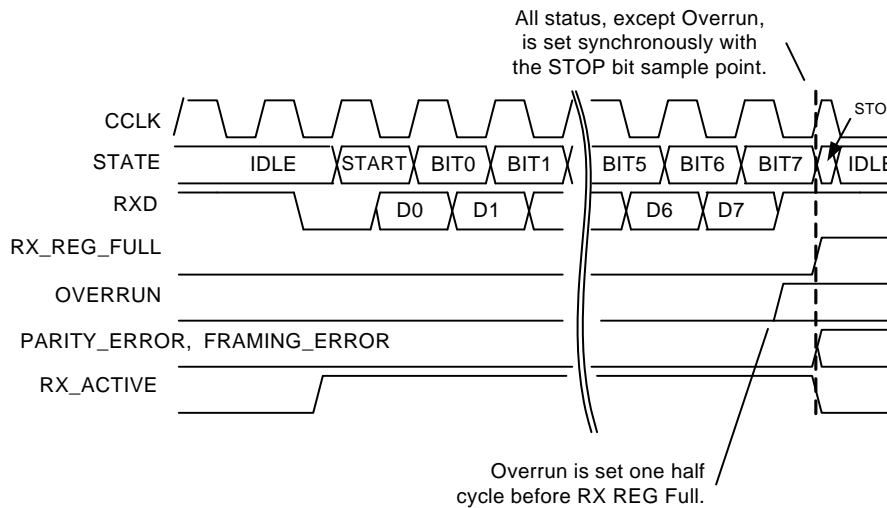

Figure 17-30. Status Timing for Receiver

Section E: Analog System



The configurable Analog System section discusses the analog components of the PSoC device and the registers associated with those components. Note that the analog output drivers are described in the PSoC Core section, [Analog Output Drivers chapter on page 111](#), because they are part of the core input and output signals. Due to their unique and limited two column functionality, also note that the analog system information for the CY8C21x34, CY8C21x23, CY7C603xx, and CYWUSB6953 PSoC devices are described in their own chapter at the end of this section. This section encompasses the following chapters:

- [Analog Interface on page 377](#)
- [Analog Array on page 395](#)
- [Analog Input Configuration on page 403](#)
- [Analog Reference on page 411](#)
- [Switched Capacitor PSoC Block on page 421](#)
- [Continuous Time PSoC Block on page 415](#)
- [Two Column Limited Analog System on page 431](#)

Top Level Analog Architecture

The figure below displays the top level architecture of the PSoC's analog system. With the exception of the analog drivers, each component of the figure is discussed at length in this section. Analog drivers are discussed in detail within the PSoC Core section, in the [Analog Output Drivers chapter on page 111](#).

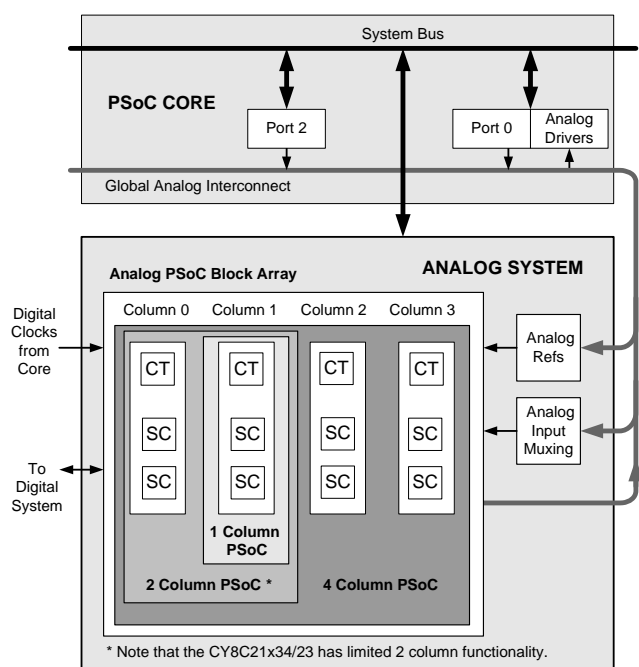

PSoC Analog System

* Note that the CY8C21x34/23 has limited 2 column functionality.

Interpreting the Analog Documentation

Information in this section covers all PSoC devices with a base part number of CY8C2xxxx (except for the CY8C25122 and CY8C26xxx devices). It also applies to CY7C64215, CY7C603xx, and CYWUSB6953. The primary analog distinction between these devices is the number of analog columns: 1, 2, or 4 columns. The following table lists the resources available for specific device groups. While reading the analog system section, determine and keep in mind the number of analog columns that are in your device, to accurately interpret the documentation.

PSoC Device Characteristics

PSoC Part Number	Digital IO (max)	Digital Rows	Digital Blocks	Analog Inputs	Analog Outputs	Analog Columns	Analog Blocks
CY8C29x66 CY8CPLC20 CY8CLED16P01	64	4	16	12	4	4	12
CY8C27x43	44	2	8	12	4	4	12
CY8C24x94	50	1	4	48	2	2	6
CY8C24x23	24	1	4	12	2	2	6
CY8C24x23A	24	1	4	12	2	2	6
CY8C22x13	16	1	4	8	1	1	3
CY8C21x34	28	1	4	28	0	2	4*
CY8C21x23	16	1	4	8	0	2	4*
CY7C64215	50	1	4	48	2	2	6
CY7C603xx	28	1	4	28	0	2	4*
CYWUSB6953	28	1	4	28	0	2	4*
CY8CNP1xx	64	4	16	12	4	4	12

* Limited analog functionality.

Application Description

PSoC blocks are user configurable system resources. On-chip analog PSoC blocks reduce the need for many MCU part types and external peripheral components. Analog PSoC blocks are configured to provide a wide variety of peripheral functions. The *PSoC Designer Software Integrated Development Environment* provides automated configuration of PSoC blocks by selecting the desired functions. PSoC Designer then generates the proper configuration information and prints a device data sheet unique to that configuration.

A precision internal voltage reference provides accurate analog comparisons. A temperature sensor input is provided to the analog PSoC block array, supporting applications such as battery chargers and data acquisition, without requiring external components.

Defining the Analog Blocks

There are three analog PSoC block types: Continuous Time (CT) blocks, and Type C and Type D Switch Capacitor (SC) blocks. CT blocks provide continuous time analog functions. SC blocks provide switched capacitor analog functions.

Each of the analog blocks has many potential inputs and several outputs. The inputs to these blocks include **analog signals** from external sources, intrinsic analog signals driven from neighboring analog blocks, or various voltage reference sources.

The analog blocks are organized into columns. Each column contains one Continuous Time (CT) block, Type B (ACB); one Switched Capacitor (SC) block, Type C (ASC); and one Switched Capacitor block, Type D (ASD). However, the number of analog columns in a specific part can either be 1, 2, or 4 columns. To determine the number of columns in your PSoC device, refer to the [PSoC Device Characteristics](#) table at the beginning of this section.

Note The CT and SC blocks in the CY8C21x34, CY8C21x23, CY7C603xx, and CYWUSB6953 devices have limited functionality compared to all other PSoC devices. Analog columns in this device contain one CT block, type E (ACE), and one SC block, type E (ASE). Refer to the [Two Column Limited Analog System](#) chapter on page 431.

The blocks in a particular column all run off the same clocking source. The blocks in a column also share some output bus resources. Refer to the [Analog Interface](#), on page 377 for additional information.

There are three types of outputs from each analog block and additional two discrete outputs in the Continuous Time blocks.

1. The analog output bus (ABUS) is an analog bus resource that is shared by all of the analog blocks in a column. Only one block in a column can actively drive this bus at any one time, with the user having control of this output through register settings. This is the only analog output that can be driven directly to a pin.
2. The comparator bus (CBUS) is a digital bus resource that is shared by all of the analog blocks in a column. Only one block in a column can be actively driving this bus at any one time, with the user having control of this output through register settings.
3. The local outputs (OUT, GOUT, and LOUT in the Continuous Time blocks) are routed to neighbor blocks. The various input **multiplexer (mux)** connections (NMux, PMux, RBotMux, AMux, BMux, and CMux) all use the output bus from one block as their input.

Analog Functionality

The following is a sampling of the functions that operate within the capability of the analog PSoC blocks, using one analog PSoC block, multiple analog blocks, a combination of more than one *type* of analog block, or a combination of analog and digital PSoC blocks. Most of these functions are currently available as **user modules** in *PSoC Designer*. Others will be added in the future. Refer to the *PSoC Designer* software for additional information and the most up-to-date list of user modules.

- Delta-Sigma Analog-to-Digital Converters
- Successive Approximation Analog-to-Digital Converters
- Incremental Analog-to-Digital Converters
- Digital to Analog Converters
- Programmable Gain/Loss Stage
- Analog Comparators
- Zero-Crossing Detectors
- Sample and Hold
- Low-Pass Filter
- Band-Pass Filter
- Notch Filter
- Amplitude Modulators
- Amplitude Demodulators
- Sine-Wave Generators
- Sine-Wave Detectors
- Sideband Detection
- Sideband Stripping
- Temperature Sensor
- Audio Output Drive
- DTMF Generator
- FSK Modulator
- Embedded Modem

By modifying registers, as described in this document, users can configure PSoC blocks to perform these functions and more. The philosophy of the analog functions supplied is as follows.

- Cost effective, single-ended configuration for reasonable speed and accuracy, providing a simple interface to most real-world analog inputs and outputs.

- Flexible, System-on-Chip programmability, providing variations in functions.
- Function specific, easily selected trade-offs of accuracy and resolution with speed, resources (number of analog blocks), and power dissipated for that application.

Analog Register Summary

The table below lists all the PSoC registers for the analog system in address order (Add. column) within their system resource configuration. The bits that are grayed out are reserved bits. If these bits are written, they should always be written with a value of '0'. The naming conventions for the SC and CT registers and their arrays of PSoC blocks are detailed in their respective table title rows.

Note that all PSoC devices, with a base part number of CY8C2xxxx (except for the CY8C25122 and CY8C26xxx PSoC devices), fall into one of the following categories with respect to their analog PSoC arrays: 4 column device, 2 column device, or 1 column device. It also applies to CY7C64215, CY7C603xx, and CYWUSB6953. The “PSoC Analog System Block Diagram” at the beginning of this section illustrates this. However, there is one modification to this rule: The CY8C21x34, CY8C21x23, CY7C603xx, and CYWUSB6953 PSoC devices have two column limited functionality. The CY8C21x34, CY7C603xx, and CYWUSB6953 analog registers are summarized and described in the [IO Analog Multiplexer chapter on page 517](#) and the CY8C21x23 analog registers are summarized and described in the [Two Column Limited Analog System chapter on page 431](#).

In the table below, the third column from the left titled “Analog Columns” indicates which of the three PSoC device categories the register falls into. To determine the number of analog columns in your PSoC device, refer to the table titled “PSoC Device Characteristics” on page 371.

Summary Table of the Analog Registers

Add.	Name	Analog Cols.	Bit 7	Bit 6	Bit 5	Bit 4	Bit 3	Bit 2	Bit 1	Bit 0	Access	
ANALOG INTERFACE REGISTERS (page 386)												
0,64h	CMP_CR0	4	COMP[3:0]				AINT[3:0]				# : 00	
		2	COMP[1:0]				AINT[1:0]					
		1	COMP[1]				AINT[1]					
0,65h	ASY_CR	4, 2	SARCNT[2:0]				SARSIGN	SARCOL[1:0]		SYNCEN		RW : 00
		1	SARCNT[2:0]				SARSIGN	SARCOL[1]	SYNCEN			
0,66h	CMP_CR1	4	CLDIS[3]	CLDIS[2]	CLDIS[1]	CLDIS[0]					RW : 00	
		2	CLDIS[1]				CLDIS[0]	CLK1X[1] CLK1X[0]				
		1	CLDIS[1]									
0,E6h	DEC_CR0	4, 2	IGEN[3:0]				ICLKS0	DCOL[1:0]		DCLKS0		RW : 00
0,E7h	DEC_CR1	4		IDEC	ICLKS3	ICLKS2	ICLKS1	DCLKS3	DCLKS2	DCLKS1		RW : 00
		2	ECNT	IDEC	ICLKS3	ICLKS2	ICLKS1	DCLKS3	DCLKS2	DCLKS1		
1,60h	CLK_CR0	4	AColumn3[1:0]		AColumn2[1:0]		AColumn1[1:0]		AColumn0[1:0]			RW : 00
		2					AColumn1[1:0]		AColumn0[1:0]			
		1					AColumn1[1:0]					
1,61h	CLK_CR1	4, 2		SHDIS	ACLK1[2:0]			ACLK0[2:0]				RW : 00
1,63h	AMD_CR0	4	AMOD2[2:0]				AMOD0[2:0]				RW : 00	
		2					AMOD0[2:0]					
1,64h	CMP_GO_EN	2	GOO5	GOO1	SEL1[1:0]		GOO4	GOO0	SEL0[1:0]			RW : 00
1,65h	CMP_GO_EN 1	2	GOO7	GOO3	SEL3[1:0]		GOO6	GOO2	SEL2[1:0]			RW : 00
1,66h	AMD_CR1	4	AMOD3[2:0]				AMOD1[2:0]				RW : 00	
		2					AMOD1[2:0]					
1,67h	ALT_CR0	4, 2	LUT1[3:0]				LUT0[3:0]				RW : 00	
		1	LUT1[3:0]									

Section E: Analog System

Summary Table of the Analog Registers (continued)

Addr.	Name	Analog Cols.	Bit 7	Bit 6	Bit 5	Bit 4	Bit 3	Bit 2	Bit 1	Bit 0	Access	
1,68h	ALT_CR1	4	LUT3[3:0]				LUT2[3:0]				RW : 00	
1,69h	CLK_CR2	4					ACLK1R			ACLK0R	RW : 00	
ANALOG INPUT CONFIGURATION REGISTERS (page 408)												
0,60h	AMX_IN	4	ACI3[1:0]		ACI2[1:0]		ACI1[1:0]		ACI0[1:0]		RW : 00	
		2					ACI1[1:0]		ACI0[1:0]			
1,62h	ABF_CR0	4	ACol1Mux	ACol2Mux	ABUF1EN	ABUF2EN	ABUF0EN	ABUF3EN	Bypass	PWR	RW : 00	
		2	ACol1Mux		ABUF1EN		ABUF0EN		Bypass	PWR		
		1	ACol1Mux		ABUF1EN				Bypass	PWR		
ANALOG REFERENCE REGISTER (page 412)												
0,63h	ARF_CR	4, 2		HBE	REF[2:0]			PWR[2:0]			RW : 00	
		2L **										RW : 00
CONTINUOUS TIME PSoC BLOCK REGISTERS (page 417)												
x,70h	ACB00CR3	4, 2					LPCMPEN	CMOUT	INSAMP	EXGAIN	RW : 00	
x,71h	ACB00CR0	4, 2	RTapMux[3:0]				Gain	RTopMux	RBotMux[1:0]		RW : 00	
x,72h	ACB00CR1	4, 2	AnalogBus	CompBus	NMux[2:0]			PMux[2:0]			RW : 00	
x,73h	ACB00CR2	4, 2	CPhase	CLatch	CompCap	TMUXEN	TestMux[1:0]		PWR[1:0]		RW : 00	
x,74h	ACB01CR3	4, 2, 1					LPCMPEN	CMOUT	INSAMP	EXGAIN	RW : 00	
x,75h	ACB01CR0	4, 2, 1	RTapMux[3:0]				Gain	RTopMux	RBotMux[1:0]		RW : 00	
x,76h	ACB01CR1	4, 2, 1	AnalogBus	CompBus	NMux[2:0]			PMux[2:0]			RW : 00	
x,77h	ACB01CR2	4, 2, 1	CPhase	CLatch	CompCap	TMUXEN	TestMux[1:0]		PWR[1:0]		RW : 00	
x,78h	ACB02CR3	4					LPCMPEN	CMOUT	INSAMP	EXGAIN	RW : 00	
x,79h	ACB02CR0	4	RTapMux[3:0]				Gain	RTopMux	RBotMux[1:0]		RW : 00	
x,7Ah	ACB02CR1	4	AnalogBus	CompBus	NMux[2:0]			PMux[2:0]			RW : 00	
x,7Bh	ACB02CR2	4	CPhase	CLatch	CompCap	TMUXEN	TestMux[1:0]		PWR[1:0]		RW : 00	
x,7Ch	ACB03CR3	4					LPCMPEN	CMOUT	INSAMP	EXGAIN	RW : 00	
x,7Dh	ACB03CR0	4	RTapMux[3:0]				Gain	RTopMux	RBotMux[1:0]		RW : 00	
x,7Eh	ACB03CR1	4	AnalogBus	CompBus	NMux[2:0]			PMux[2:0]			RW : 00	
x,7Fh	ACB03CR2	4	CPhase	CLatch	CompCap	TMUXEN	TestMux[1:0]		PWR[1:0]		RW : 00	
SWITCHED CAPACITOR PSoC BLOCK REGISTERS (page 424)												
Switched Capacitor Block Registers, Type C (page 425)												
x,80h	ASC10CR0	4, 2	FCap	ClockPhase	ASign					ACap[4:0]	RW : 00	
x,81h	ASC10CR1	4, 2	ACMux[2:0]								BCap[4:0]	RW : 00
x,82h	ASC10CR2	4, 2	AnalogBus	CompBus	AutoZero					CCap[4:0]	RW : 00	
x,83h	ASC10CR3	4, 2	ARefMux[1:0]		FSW1	FSW0	BMuxSC[1:0]		PWR[1:0]		RW : 00	
x,88h	ASC12CR0	4	FCap	ClockPhase	ASign					ACap[4:0]	RW : 00	
x,89h	ASC12CR1	4	ACMux[2:0]								BCap[4:0]	RW : 00
x,8Ah	ASC12CR2	4	AnalogBus	CompBus	AutoZero					CCap[4:0]	RW : 00	
x,8Bh	ASC12CR3	4	ARefMux[1:0]		FSW1	FSW0	BMuxSC[1:0]		PWR[1:0]		RW : 00	
x,94h	ASC21CR0	4, 2, 1	FCap	ClockPhase	ASign					ACap[4:0]	RW : 00	
x,95h	ASC21CR1	4, 2, 1	ACMux[2:0]								BCap[4:0]	RW : 00
x,96h	ASC21CR2	4, 2, 1	AnalogBus	CompBus	AutoZero					CCap[4:0]	RW : 00	
x,97h	ASC21CR3	4, 2, 1	ARefMux[1:0]		FSW1	FSW0	BMuxSC[1:0]		PWR[1:0]		RW : 00	
x,9Ch	ASC23CR0	4	FCap	ClockPhase	ASign					ACap[4:0]	RW : 00	
x,9Dh	ASC23CR1	4	ACMux[2:0]								BCap[4:0]	RW : 00
x,9Eh	ASC23CR2	4	AnalogBus	CompBus	AutoZero					CCap[4:0]	RW : 00	
x,9Fh	ASC23CR3	4	ARefMux[1:0]		FSW1	FSW0	BMuxSC[1:0]		PWR[1:0]		RW : 00	
Switched Capacitor Block Registers, Type D (page 428)												
x,84h	ASD11CR0	4, 2, 1	FCap	ClockPhase	ASign					ACap[4:0]	RW : 00	
x,85h	ASD11CR1	4, 2, 1	AMux[2:0]								BCap[4:0]	RW : 00

Summary Table of the Analog Registers (continued)

Add.	Name	Analog Cols.	Bit 7	Bit 6	Bit 5	Bit 4	Bit 3	Bit 2	Bit 1	Bit 0	Access
x,86h	ASD11CR2	4, 2, 1	AnalogBus	CompBus	AutoZero	CCap[4:0]				RW : 00	
x,87h	ASD11CR3	4, 2, 1	ARefMux[1:0]		FSW1	FSW0	BSW	BMuxSD	PWR[1:0]		RW : 00
x,8Ch	ASD13CR0	4	FCap	ClockPhase	ASign	ACap[4:0]				RW : 00	
x,8Dh	ASD13CR1	4	AMux[2:0]			BCap[4:0]				RW : 00	
x,8Eh	ASD13CR2	4	AnalogBus	CompBus	AutoZero	CCap[4:0]				RW : 00	
x,8Fh	ASD13CR3	4	ARefMux[1:0]		FSW1	FSW0	BSW	BMuxSD	PWR[1:0]		RW : 00
x,90h	ASD20CR0	4, 2	FCap	ClockPhase	ASign	ACap[4:0]				RW : 00	
x,91h	ASD20CR1	4, 2	AMux[2:0]			BCap[4:0]				RW : 00	
x,92h	ASD20CR2	4, 2	AnalogBus	CompBus	AutoZero	CCap[4:0]				RW : 00	
x,93h	ASD20CR3	4, 2	ARefMux[1:0]		FSW1	FSW0	BSW	BMuxSD	PWR[1:0]		RW : 00
x,98h	ASD22CR0	4	FCap	ClockPhase	ASign	ACap[4:0]				RW : 00	
x,99h	ASD22CR1	4	AMux[2:0]			BCap[4:0]				RW : 00	
x,9Ah	ASD22CR2	4	AnalogBus	CompBus	AutoZero	CCap[4:0]				RW : 00	
x,9Bh	ASD22CR3	4	ARefMux[1:0]		FSW1	FSW0	BSW	BMuxSD	PWR[1:0]		RW : 00

LEGEND

x An "x" before the comma in the address field indicates that this register can be accessed or written to no matter what bank is used.

Access is bit specific. Refer to the [Register Details chapter on page 147](#) for additional information.

R Read register or bit(s).

W Write register or bit(s).

** The 2L column row is only applicable to the CY8C21x34, CY8C21x23, CY7C603xx, and CYWUSB6953 PSoC device which has two column limited ** analog functionality.

18. Analog Interface



This chapter explains the Analog Interface and its associated registers. The analog system interface is a collection of system level interfaces to the analog array and analog reference block. For information on the analog interface for the CY8C21x34, CY8C21x23, CY7C603xx, and CYWUSB6953 PSoC devices, refer to the [Two Column Limited Analog System](#) chapter on page 431. For a complete table of the analog interface registers, refer to the “[Summary Table of the Analog Registers](#)” on page 373. For a quick reference of all PSoC registers in address order, refer to the [Register Details](#) chapter on page 147.

18.1 Architectural Description

Figure 18-1 displays the top level diagram of the PSoC device's analog interface system.

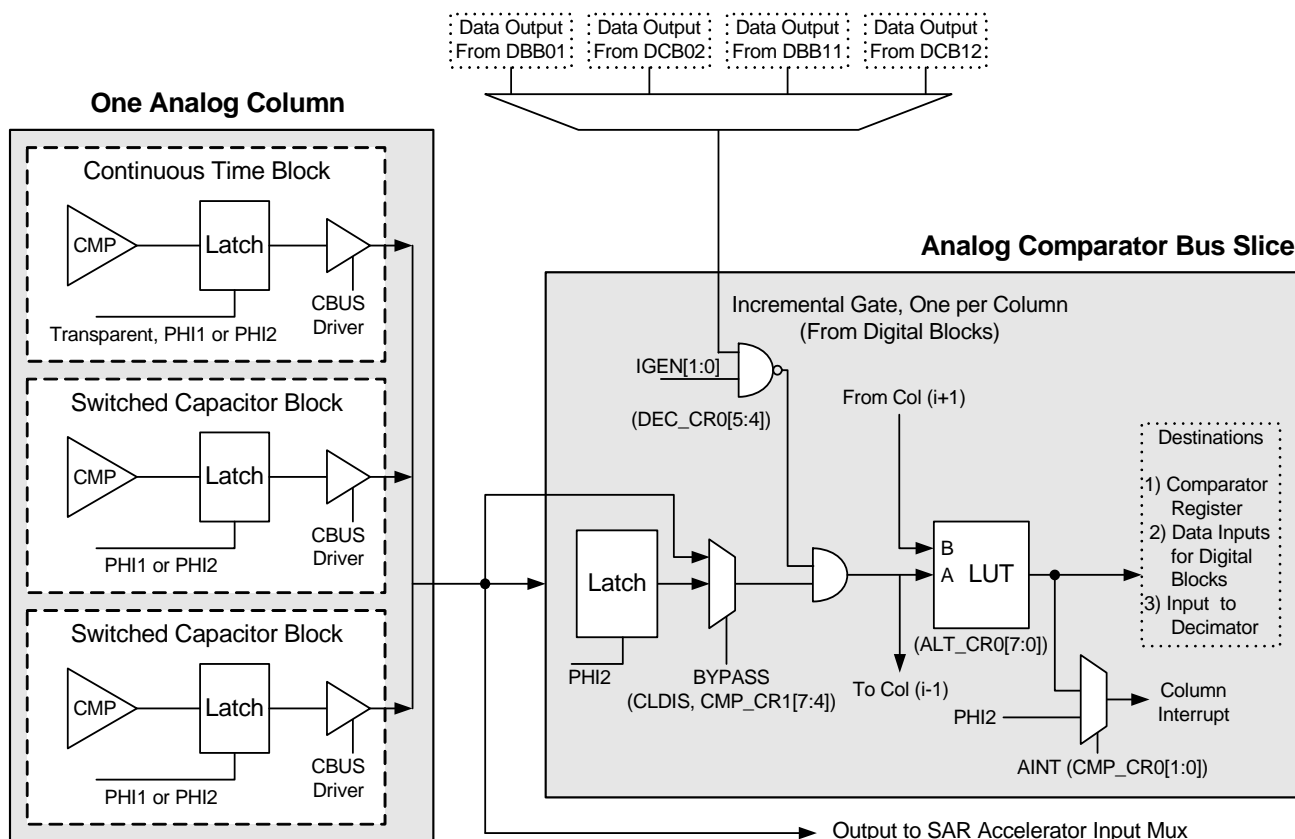

Figure 18-1. Analog Comparator Bus Slice

18.1.1 Analog Data Bus Interface

The Analog Data Bus Interface isolates the analog array and analog system interface registers from the CPU system data bus, to reduce bus loading. Transceivers are implemented on the system data bus to isolate the analog data bus from the system data bus. This creates a local analog data bus.

18.1.2 Analog Comparator Bus Interface

Each analog column has a dedicated comparator bus associated with it. Every analog PSoC block has a comparator output that can drive this bus. However, only one analog block in a column can actively drive the comparator bus for a column at any one time. The output on the comparator bus drives into the digital blocks as a data input. It also serves as an input to the decimator, as an interrupt input, and is available as read only data in the Analog Comparator Control register (CMP_CR0).

Figure 18-1 illustrates one column of the comparator bus. In the Continuous Time (CT) analog blocks, the CPhase and CLatch bits of CT Block Control Register 2 determine whether the output signal on the comparator bus is latched inside the block, and if it is, which clock phase it is latched on. In the Switched Capacitor (SC) analog blocks, the output on the comparator bus is always latched. The ClockPhase bit in SC Block Control Register 0 determines the phase on which this data is latched and available.

The comparator bus is latched before it is available, to either drive the digital blocks, interrupt, decimator, or for it to be read in the CMP_CR0 register. The latch for each comparator bus is transparent (the output tracks the input) during the high period of PHI2. During the low period of PHI2, the latch retains the value on the comparator bus during the high-to-low transition of PHI2. The CMP_CR0 register is described in the “CMP_CR0 Register” on page 386. There is also an option to force the latch in each column into a transparent mode by setting bits in the CMP_CR1 register.

The CY8C24x94 and CY7C64215 PSoC devices have an additional comparator synchronization option in which the 1X direct column clock selection is used to synchronize the analog comparator bus. This allows for higher frequency comparator sampling.

As shown in Figure 18-1, the comparator bus output is gated by the primary output of a selected digital block. This feature is used to precisely control the integration period of an incremental ADC. Any digital block can be used to drive the gate signal. This selection may be made with the ICLKS bits in registers DEC_CR0 and DEC_CR1. This function may be enabled on a column-by-column basis, by setting the IGEN bits in the DEC_CR0 register.

The analog comparator bus output values can be modified or combined with another analog comparator bus through the Analog **look-up table (LUT)** function. The LUT takes two inputs, A and B, and provides a selection of 16 possible logic functions for those inputs. The LUT A and B inputs for each column comparator output is shown in the following table.

In the CY8C21x34, CY8C21x23, CY7C603xx, and CYWUSB6953 PSoC devices, only the CT comparator can drive the comparator bus.

Table 18-1. A and B Inputs for Each Column Comparator LUT Output

Comparator LUT Output	A	B
4 Column PSoCs		
Column 0	ACMP0	ACMP1
Column 1	ACMP1	ACMP2
Column 2	ACMP2	ACMP3
Column 3	ACMP3	ACMP0
2 Column PSoCs		
Column 0	ACMP0	ACMP1
Column 1	ACMP1	0
Column 2	0	0
Column 3	0	ACMP0
1 Column PSoCs		
Column 0	ACMP0	0
Column 1	0	0
Column 2	0	0
Column 3	0	ACMP0

The LUT configuration is set in two control registers, ALT_CR0 and ALT_CR1. Each selection for each column is encoded in four bits. The function value corresponding to the bit encoding is shown in the following table.

Table 18-2. RDIxLTx Register

LUTx[3:0]	0h: 0000: FALSE 1h: 0001: A .AND. B 2h: 0010: A .AND. B̄ 3h: 0011: A 4h: 0100: Ā .AND. B 5h: 0101: B 6h: 0110: A .XOR. B 7h: 0111: A .OR. B 8h: 1000: A .NOR. B 9h: 1001: A .XNOR. B Ah: 1010: B̄ Bh: 1011: Ā .OR. B̄ Ch: 1100: Ā Dh: 1101: Ā .OR. B Eh: 1110: A .NAND. B Fh: 1111: TRUE
-----------	---

18.1.3 Analog Column Clock Generation

The analog array switched capacitor blocks require a two-phase, non-overlapping clock. The switched cap blocks are arranged in four columns, two to a column (a third block in the column is a continuous time block).

An analog column clock generator is provided for each column and this clock is shared among the blocks in that column. The input clock source for each column clock generator is selectable according to the `CLK_CR0` register. It is important to note that regardless of the clock source selected, the output frequency of the column clock generator is the input frequency divided by four. There are four selections for each column: V1, V2, ACLK0, and ACLK1. The V1 and V2 clock signals are global system clocks. Programming options for these system clocks can be accessed in the `OSC_CR1` register. Each of the ACLK0 and ACLK1 clock selections are driven by a selection of digital block's primary outputs. The settings for the digital block selection are located in register `CLK_CR1` and the register `CLK_CR2`.

The timing for analog column clock generation is shown in Figure 18-2. The dead band time between two phases of the clock is designed to be a minimum of 21 ns.

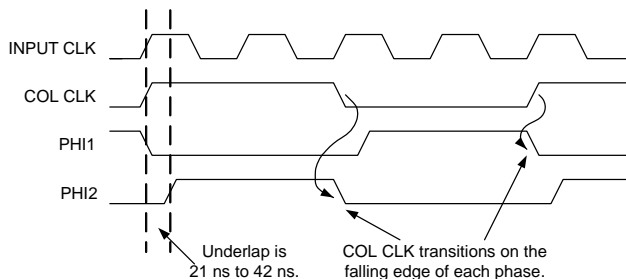

Figure 18-2. Two Phase Non-Overlapping Clock Generation

18.1.3.1 Column Clock Synchronization

Note that this function is not in the CY8C21x34, CY8C21x23, CY7C603xx, and CYWUSB6953 PSoC devices.

When analog signals are routed between blocks in adjacent columns, it is important that the clocks in these columns are synchronized in phase and frequency. Frequency synchronization may be achieved by selecting the same input source to two or more columns. However, there is a special feature of the column clock interface logic that provides a resynchronization of clock phase. This function is activated on any IO write to either the Column Clock Selection register (`CLK_CR0`) or the Reference Calibration Clock register (`RCL_CR`). A write to either of these registers initiates a synchronous reset of the column clock generators, restarting all clocks to a known state. This action causes all columns with the same selected input frequency to be in phase. Writing these registers should be avoided during critical analog pro-

cessing, as column clocks are all re-initialized and thus a discontinuity in PHI1/PHI2 clocking will occur.

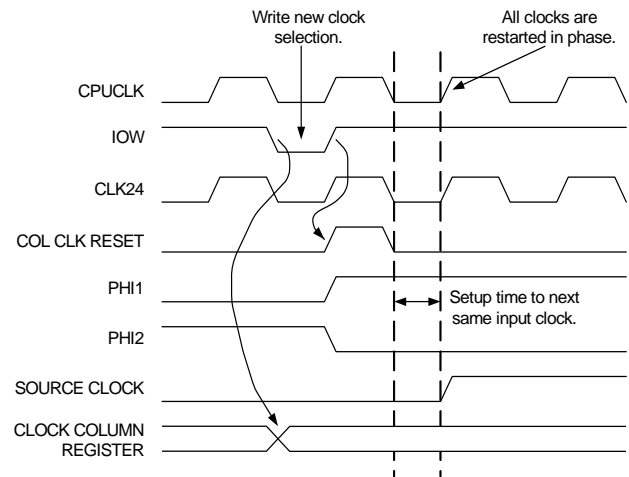

Figure 18-3. Column Clock Resynchronize on an IO Write

18.1.4 Decimator and Incremental ADC Interface

The Decimator and Incremental ADC Interface provides hardware support and signal routing for analog-to-digital conversion functions, specifically the Delta Signal ADC and the Incremental ADC. The control signals for this interface are split between two registers: `DEC_CR0` and `DEC_CR1`.

18.1.4.1 Decimator

The Decimator is a hardware block that is used to perform digital processing on the analog block outputs. Note that the decimator function is not in the CY8C21x34, CY8C21x23, CY7C603xx, and CYWUSB6953 PSoC devices.

The `DCLKS0` and `DCLKS1` bits, which are split between the `DEC_CR0` and `DEC_CR1` registers, are used to select a source for the decimator output latch enable. The decimator is typically run autonomously over a given period. The length of this period is set in a timer block that is running in conjunction with the analog processing. At the terminal count of this timer, the primary output goes high for one clock cycle. This pulse is translated into the decimator output latch enable signal, which transfers data from the internal accumulators to an output buffer. The terminal count also causes an interrupt and the CPU may read this output buffer at any time between one latch event and the next.

18.1.4.2 Incremental ADC

The analog interface has support for the incremental ADC operation through the ability to gate the analog comparator outputs. This gating function is required in order to precisely control the digital integration period that is performed in a digital block, as part of the function. A digital block pulse width modulator (PWM) is used as a source to provide the

gate signal. Only one source for the gating signal can be selected. However, the gating can be applied independently to any of the column comparator outputs.

The ICLKS bits, which are split between the DEC_CR0 and DEC_CR1 registers, are used to select a source for the incremental gating signal. The four IGEN bits are used to independently enable the gating function on a column-by-column basis.

The CY8C21x34, CY8C21x23, CY7C603xx, and CYWUSB6953 PSoC devices contain a dedicated block that can perform this gating function using VC3. When this dedicated PWM is configured, it overrides the ICLKS selection as defined by the DEC_CR0 and DEC_CR1 registers.

18.1.5 Analog Modulator Interface (Mod Bits)

The Analog **Modulator** Interface provides a selection of signals that are routed to any of the four analog array **modulation** control signals. There is one modulation control signal for each Type C Analog Switched Capacitor block in every analog column. There are eight selections, which include the analog comparator bus outputs, two global outputs, and a digital block broadcast bus. The selections for all columns are identical and are contained in the AMD_CR0 and AMD_CR1 registers. The Mod bit is XOR'ed with the Switched Capacitor block **sign bit** (ASign in ASCxxCR0) to provide dynamic control of that bit.

18.1.6 Analog Synchronization Interface (Stalling)

Note that this function is not in the CY8C21x34, CY8C21x23, CY7C603xx, and CYWUSB6953 PSoC devices.

For high precision analog operation, it is necessary to precisely time when updated register values are available to the analog PSOC blocks. The optimum time to update values in Switch Capacitor registers is at the beginning of the PHI1 active period. Depending on the relationship between the CPU CLK and the analog column clock, the CPU IO write cycle can occur at any 24 MHz master clock boundary in the PHI1 or PHI2 cycle. Register values may be written at arbitrary times; however, glitches may be apparent at analog outputs. This is because the capacitor value is changing when the circuit is designed to be settling.

The SYNCEN bit in the Analog Synchronization Control register (ASY_CR) is designed to address this problem. When the SYNCEN bit is set, an IO write instruction to any Switch Capacitor register is blocked at the interface and the CPU will stall. On the subsequent rising edge of PHI1, the CPU stall is released, allowing the IO write to be performed at the destination analog register. This mode synchronizes the IO write action to perform at the optimum point in the analog cycle, at the expense of CPU **bandwidth**. Figure 18-4 shows the timing for this operation.

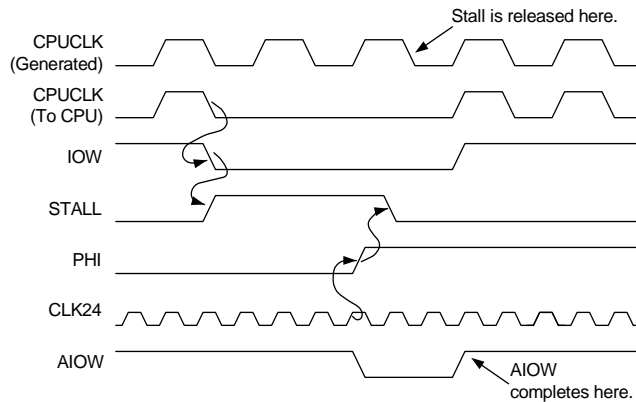

Figure 18-4. Synchronized Write to a DAC Register

As an alternative to stalling, the source for the analog column interrupts is set as the falling edge of the PHI2 clock. This configuration synchronizes the CPU to perform the IO write after the PHI2 phase is completed, which is equivalent to the start of PHI1.

18.2 PSoC Device Distinctions

The DEC_CR1 register's bit 7 (ECNT) is only available in PSoC devices with a type 1 decimator and is reserved in PSoC devices with a type 2 decimator. Refer to the table titled "Decimator Availability for PSoC Devices" on page 475 to determine which type of decimator your PSoC device uses.

The CMP_GO_EN and CMP_GO_EN1 registers, which allow connection of analog interface signals to the global bus, are only available in the CY8C24x94 and CY7C64215 PSoC devices, with the exception that the CMP_GO_EN register is also available to devices that have two column limited functionality such as the CY8C21x34, CY8C21x23, CY7C603xx, and CYWUSB6953 PSoC devices.

In the CMP_CR1 register, bits 1 and 0 (CLK1X[1] and CLK1X[0]) are only available for the CY8C24x94 and CY7C64215 PSoC devices.

18.3 Application Description

18.3.1 SAR Hardware Acceleration

Note that this function is not in the CY8C21x34, CY8C21x23, CY7C603xx, and CYWUSB6953 PSoC devices.

The Successive Approximation Register (SAR) **algorithm** is a binary search on the Digital-to-Analog Converter (DAC) code that best matches the input voltage that is being measured. The first step is to take an initial guess at mid-scale, which effectively splits the range by half. The DAC output value is then compared to the input voltage. If the guess is too low, a result bit is set for that binary position and the next guess is set at mid-scale of the remaining upper range. If the guess is too high, a result bit is cleared and the next

guess is set at mid-scale of the remaining lower range. This process is repeated until all bits are tested. The resulting DAC code is the value that produces an output voltage closest to the input voltage. This code should be within one LSB of the input voltage.

The successive approximation analog-to-digital algorithm requires the following building blocks: a DAC, a comparator, and a method or apparatus to sequence successive writes to the DAC based on the comparator output. The SAR hardware accelerator represents a trade off between a fully automatic hardware sequencing approach and a pure firmware approach.

18.3.1.1 Architectural Description

The architectural description for the SAR hardware accelerator is illustrated in Figure 18-5.

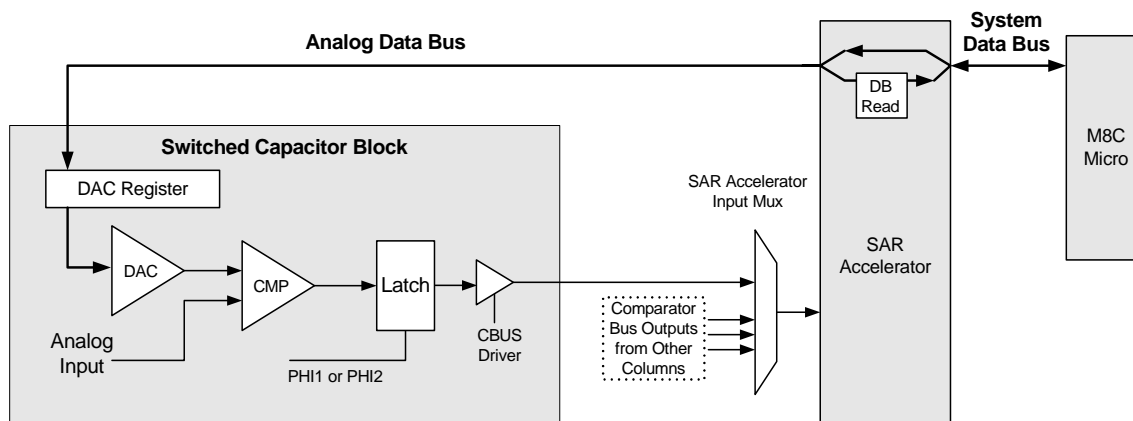

Figure 18-5. SAR Hardware Accelerator

As shown in Figure 18-5, the SAR accelerator hardware is interfaced to the analog array through the comparator output and the analog array data bus. To create DAC output, values are written directly to the ACAP field in the DAC register. To facilitate the sequencing of the DAC writes in the SAR algorithm, the M8C is programmed to do a sequence of READ, MODIFY, and WRITE instructions. This is an atomic operation that consists of an IO read (IOR) followed closely by an IO write (IOW). One example of an assembly level instruction is as follows.

```
OR reg[DAC_REG],0
```

The effect of this instruction is to read the DAC register and follow it closely in time by a write back. The OR instruction does not modify the read data (it is OR'ed with '0'). The CPU does not need to do any additional computation in conjunction with this procedure. The SAR hardware transparently does the data modification during the read portion of the cycle. The only purpose for executing this instruction is to initiate a read that is modified by the SAR hardware, then to

follow up with a write that transfers the data back to the DAC register.

During each IO read operation, the SAR hardware overrides two bits of the data:

- To correct the previous bit guess based on the current comparator value.
- To set the next guess (next least significant bit).

The CPU latches this SAR modified data, OR's it with '0' (no CPU modification), and writes it back to the DAC register. A counter in the SAR hardware is used to decode which bits are being operated on in each cycle. In this way, the capability of the CPU and the IOR/IOW control lines are used to implement the read and write. Use the SAR accelerator hardware to make the decisions and to control the values written, achieving the optimal level of performance for the current system.

The SAR hardware is designed to process six bits of a result in a given sequence. A higher resolution SAR is implemented with multiple passes.

18.3.1.2 Application Description

There are a number of ways to map a SAR6 module into the analog array. A SAR6 can be created from 1 SC block, 2 SC blocks, or 1 SC block and 1 CT block. In the following example, the programming, the clock selection, connectivity, inputs, of a two block SAR6 will be demonstrated.

This type of SAR6 is made up of 1 SC block that operates as a DAC6, and 1 SC block that operates as a voltage summer and comparator. The 2 block SAR6 is placed in column 0 as shown in Figure 18-6.

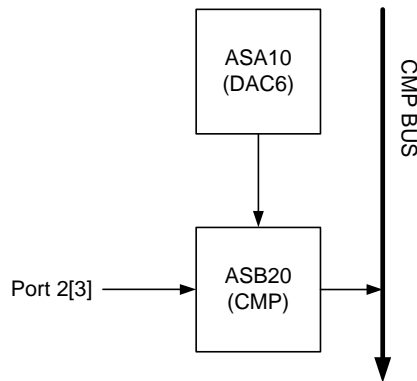

Figure 18-6. SAR6 Module Example

The programming for the DAC6 block is as follows:

```
CR0: mov reg[ASC10CR0], a0h
      // Full Feedback, ACap Value = >
      // Start with Sign = 1
CR1: mov reg[ASC10CR1], 40h
      // Select REFHI for DAC function
CR2: mov reg[ASC10CR2], a0h
      // OBUS ON, Auto-Zero ON
CR3: mov reg[ASC10CR3], 33h
      // Feedback ON, Power ON
```

The programming for the SUMMING/COMPARATOR block is as follows:

```
CR0: mov reg[ASD20CR0], bfh
      // Full Feedback, Sign = 1, ACap = 31
CR1: mov reg[ASC20CR1], 3fh
      // A Input = P2_3, BCap = 31
CR2: mov reg[ASC20CR2], 60h
      // Cmp Bus ON, Auto Zero ON
CR3: mov reg[ASC20CR3], 17h
      // Feedback OFF, B Input = North
```

Firmware Support Examples

In addition to the use of the OR instruction to sequence the algorithm, there are some minimal setup requirements. The SAR control bits are in the ASY_CR register. The definition of these bits as related to the SAR are as follows.

Bits [2:1] Column Select for the SAR Comparator Input

The DAC portion of the SAR can reside in any of the appropriate positions in the analog PSOC block array. However, once the COMPARATOR block is positioned (and it is possible to have the DAC and COMPARATOR in the same block), this should be the column selected.

Bit [3] Sign Selection

This bit optionally inverts the comparator input to the SAR accelerator. It must be set based on the type of PSOC block configuration selected. Some typical examples are listed in Table 18-3.

Table 18-3. Example SAR Configuration

Configuration	Description	Sign
SAR6 – 2 block	1 DAC6, 1 COMP (could be CT)	0
SAR6 – 1 block	1 for both DAC6 and COMP	1
MS SAR10 – 3 blocks	1 DAC9, 1 COMP (could be CT) (when processing MS DAC block)	0
LS SAR10 – 3 blocks	1 DAC9, 1 COMP (could be CT) (when processing LS DAC block)	1

Bits [6:4] SAR Count Value

These three bits are used to initialize a 3-bit counter to sequence the 6 bits of the SAR algorithm. Typically, the user would initialize this register to '6'. When these bits are any value other than '0', an IOR command to an SC block is assumed to be part of a SAR sequence.

Assuming the comparator bus output is programmed for column 0, a typical firmware sequence would be as follows.

```
mov reg[ASY_CR], 60h // SAR count value=6,
                    // Sign=0, Col=0
or reg[ASC10CR0], 0 // Check sign, set bit 4
or reg[ASC10CR0], 0 // Check bit 4, set bit 3
or reg[ASC10CR0], 0 // Check bit 3, set bit 2
or reg[ASC10CR0], 0 // Check bit 2, set bit 1
or reg[ASC10CR0], 0 // Check bit 1, set bit 0
or reg[ASC10CR0], 0 // Check bit 0
```

SAR6 Calculation Example

This example assumes an input voltage level (V_{IN}) of 3.0V on the PSoC input pin. The selection is made of +/- VREF for the DAC references. Assuming VREF = 1.25, the input range will be from 1.25 to 3.75 volts. The 6-bit DAC will yield a sign magnitude result with 64 discrete values, thus giving 39 mV of resolution over the input range.

With 3.0V input, the expected magnitude of the result is (3.0-2.5)/1.25 * 32 = 12.8. The expected sign of the result is '0', meaning positive; therefore, the result is Sign=0, Magnitude=12 or 13. The error in this basic SAR algorithm is always less than one LSb in the final result.

Table 18-4 shows the sequence of calculations which correspond to the six OR instructions.

The final result of the computation is:

Sign = 1 and Magnitude = 011000 or 12.

To represent the true sign of the input voltage, you must invert the sign of the result from the DAC register. Therefore the result becomes Sign = 0, Magnitude = 12 which is $(3.75 - 2.5)/32 * 12 + 2.5 = 2.96875$. The error is 31.25 mV, or less than one LSb of 39 mV.

Table 18-4. SAR Sequence Example

Step	Current ACap	VIn	VDac	VSum	Comparator Bus (CMP)	New ACap	Comment
1	100000	3.0	2.5	2.75	0	110000	Keep the sign bit and set bit 4.
2	110000	3.0	1.875	2.4375	1	101000	Overshoot, clear bit 4, set bit 3.
3	101000	3.0	2.1875	2.59375	0	101100	Keep bit 3, and set bit 2.
4	101100	3.0	2.03125	2.515625	0	101110	Keep bit 2, and set bit 1.
5	101110	3.0	1.953125	2.4765625	1	101101	Overshoot, clear bit 1, set bit 0.
6	101101	3.0	1.992188	2.496094	1	101100	Overshoot, clear bit 0
	101100	3.0	2.03125	2.515625	0	101100	Final Result

Notes

1. VSum is the voltage at the summing node, that is, the input to the comparator.
2. VDac is the voltage generated by the DAC block from the ACap value.
3. When VSum > AGND, CMP = 0; when VSum < AGND, CMP = 1.
4. CMP = 0 means keep the bit (undershoot); CMP = 1 means clear the bit (overshoot).
5. Start with Sign = 1 (configuration programming), equivalent to setting that bit to test.

As shown in Table 18-4, the value of the result from Step 5, Magnitude = 13, is closer to the actual value of 12.8. This demonstrates that even though it is possible that the resulting code could be closer to the actual value, in the SAR algorithm there is no provision to detect this. The result is a maximum theoretical error of less than one LSb.

Implementing Higher Resolution SARs

It is straightforward to implement higher resolution SARs using the SAR hardware accelerator. For example, to create an 11-bit SAR, 3 blocks would be allocated: 2 SC blocks to make a DAC9 and one SC or CT block for summing and compare.

To get the results of the most significant (MS) block, which is the first 6 bits (Sign and 5 bits of Magnitude), the firmware sequencing would proceed exactly as in the previous SAR6 example.

The trick with the least significant (LS) block of the DAC9 is to get the sign right. For the output to be correct, the sign of the LS block of a DAC9 should be opposite to that of the MS block (since it is connected through an inverting input to the MS block).

There are two possible ways to handle this.

1. In firmware, one can manually compute what the sign bit should be from the result in the MS block and write it to the LS block. Then the SAR count value should be set to 5 instead of 6 to skip the sign bit check.
2. An interesting property of the SAR algorithm is that the resulting voltage at the summing node after the first 6 steps (MS block processing) is going to be the same polarity (above or below AGND) as the input voltage. The reason for this is that, by definition, if the polarity of

the summing voltage is opposite to that of the input voltage, this triggers a Clear of the previous bit set. Since, also by definition, the final result of the summing voltage is less than one LSb from AGND, clearing the LSb will result in a summing voltage of the same polarity as the input voltage.

According to number 2 above, the sign bit of the LS block can be handled exactly as the sign bit of the MS block, just another OR instruction. This sequence would then be appended on the above MS processing sequence (substituting the LS DAC block address for <LS_CR0>). Note that the meaning of the comparator is inverted by setting the SIGN bit in the ASYNC Control register. This is because the LS block is inverted with respect to the MS block.

```
mov reg[ASY_CR], 68h // SAR count value=6,
                        // Sign=1, Col=0
```

```
or reg[<LS_CR0>], 0 // Check sign, set bit 4
or reg[<LS_CR0>], 0 // Check bit 4, set bit 3
or reg[<LS_CR0>], 0 // Check bit 3, set bit 2
or reg[<LS_CR0>], 0 // Check bit 2, set bit 1
or reg[<LS_CR0>], 0 // Check bit 1, set bit 0
or reg[<LS_CR0>], 0 // Check bit 0
```

18.3.1.3 SAR Timing

Another important function of the SAR hardware is to synchronize the IO read (the point at which the comparator value is used to make the SAR decision) to when the analog comparator bus is valid. Under normal conditions, this point is at the rising edge of PHI1 for the previous compute cycle. When the OR instruction is executed in the CPU, a few CPU clocks cycle into the instruction and an IOR signal is asserted to initiate a read of the DAC register. The SAR

hardware then stalls the CPU clock, for one 24 MHz clock cycle after the rising edge of PHI1. When the stall is released, the IO Read completes and is immediately followed by an IO write. In this sequence of events, the DAC register is written with the new value within a few CPU clocks after PHI1.

The rising edge of PHI1 is also the optimal time to write the DAC register for maximum settling time. The timing from the positive edge of PHI1 to the start of the IO write is 4.5 clocks, which at 24 MHz is 189 ns. If the analog clock is running at 1 MHz, this allows over 300 ns for the DAC output and comparator to settle.

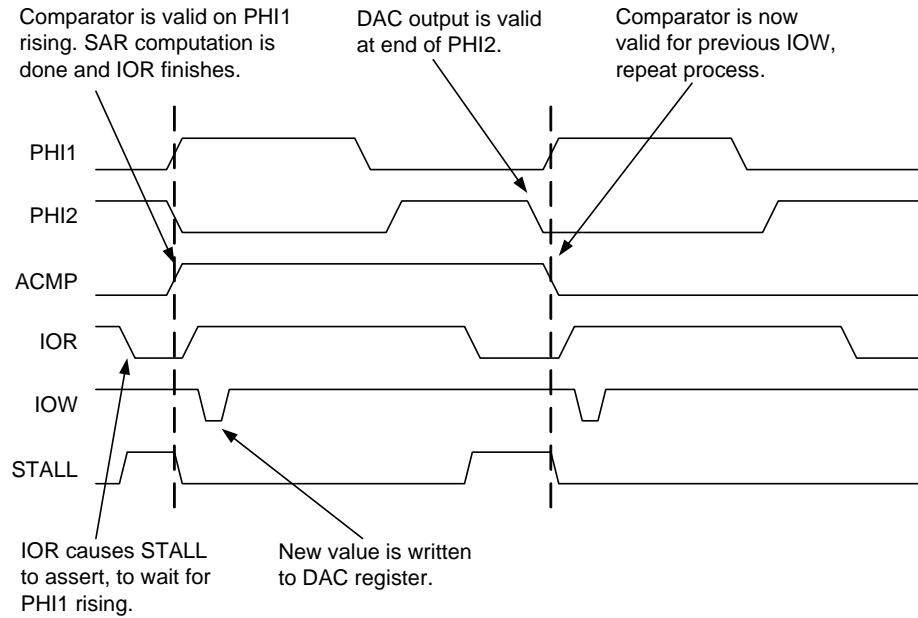

Figure 18-7. General SAR Timing

18.4 Register Definitions

The following registers are associated with the Analog Interface and are listed in address order. Each register description has an associated register table showing the bit structure for that register. Note that the analog interface register definitions for the CY8C21x34, CY8C21x23, CY7C603xx, and CYWUSB6953 PSoC devices are listed in the [Two Column Limited Analog System](#) chapter on page 431. For a complete table of analog interface registers, refer to the “Summary Table of the Analog Registers” on page 373.

Depending on how many analog columns your PSoC device has (see the Cols. column in the register tables below), only certain bits are accessible to be read or written (refer to the table titled “PSoC Device Characteristics” on page 371). The bits that are grayed out throughout this manual are reserved bits and are not detailed in the register descriptions that follow. Reserved bits should always be written with a value of ‘0’.

18.4.1 CMP_CR0 Register

Addr.	Name	Cols.	Bit 7	Bit 6	Bit 5	Bit 4	Bit 3	Bit 2	Bit 1	Bit 0	Access
0,64h	CMP_CR0	4	COMP[3:0]				AINT[3:0]				# : 00
		2			COMP[1:0]				AINT[1:0]		
		1			COMP[1]			AINT[1]			

#: Access is bit specific. Refer to the [Register Details](#) chapter on page 147.

The Analog Comparator Bus Register 0 (CMP_CR0) is used to poll the analog column comparator bits and select column interrupts.

This register contains two fields: COMP and AINT. By default, the interrupt is the comparator bit. A rising edge on a comparator bit causes an interrupt to be registered. However, if a bit in this field is set, the interrupt input for that column will be derived from the falling edge of PHI2 clock for that column (that is, the falling edge of PHI2 will leave a rising interrupt signal). Firmware can use this capability to synchronize to the current column clock.

In the CY8C21x34, CY8C21x23, CY7C603xx, and CYWUSB6953 PSoC devices, the AINT[1:0] bits are tied low so only the comparators can drive the analog interface.

Bits 7 to 4: COMP[x]. These bits are the read only bits corresponding to the comparator bits in each analog column. They are synchronized to the column clock, and thus may be reliably polled by the CPU.

Bits 3 to 0: AINT[x]. These bits select the interrupt source for each column, as the input to the interrupt controller.

For additional information, refer to the [CMP_CR0 register](#) on page 180.

18.4.2 ASY_CR Register

Add.	Name	Cols.	Bit 7	Bit 6	Bit 5	Bit 4	Bit 3	Bit 2	Bit 1	Bit 0	Access
0,65h	ASY_CR	4, 2			SARCNT[2:0]		SARSIGN		SARCOL[1:0]	SYNCEN	RW : 00
		1			SARCNT[2:0]		SARSIGN	SARCOL[1]		SYNCEN	

The Analog Synchronization Control Register (ASY_CR) is used to control SAR operation, except for bit 0, SYNCEN.

SYNCEN is associated with analog register write stalling and is described in “Analog Synchronization Interface (Stalling)” on page 381.

The SAR hardware accelerator is a block of specialized hardware designed to sequence the SAR algorithm for efficient analog-to-digital conversion. A SAR ADC is implemented conceptually with a DAC of the desired precision and a comparator. This functionality is configured from one or more PSoC blocks. For each conversion, the firmware should initialize the ASY_CR register and set the sign bit of the DAC as the first guess in the algorithm. A sequence of OR instructions (read, modify, write) to the ASxxxCR0 register is then executed. Each of these OR instructions causes the SAR hardware to read the current state of the comparator, checking the validity of the previous guess. It either clears it or leaves it set, accordingly. The next LSB in the DAC register is also set as the next guess. Six OR instructions will complete the conversion of a 6-bit DAC. The resulting DAC code, which matches the input voltage to within one LSB, is then read back from the ASxxxCR0 register.

Bits 6 to 4: SARCNT[2:0]. These bits are the SAR count value and are used to initialize a three-bit counter to sequence the six bits of the SAR algorithm. Typically, the user would initialize this register to ‘6’. When these bits are any value other than ‘0’, a register read command to an SC block is assumed to be part of a SAR sequence.

Assuming the comparator bus output is programmed for column 0, a typical firmware sequence would be as follows.

```
mov reg[ASY_CR], 60h // SAR count value=6,
                    // Sign=0, Col=0
or reg[ASC10CR0], 0 // Check sign, set bit 4
or reg[ASC10CR0], 0 // Check bit 4, set bit 3
or reg[ASC10CR0], 0 // Check bit 3, set bit 2
or reg[ASC10CR0], 0 // Check bit 2, set bit 1
or reg[ASC10CR0], 0 // Check bit 1, set bit 0
or reg[ASC10CR0], 0 // Check bit 0
```

Bit 3: SARSIGN. This bit is the SAR sign selection and optionally inverts the comparator input to the SAR accelerator. It must be set based on the type of PSoC block configuration selected. Table 18-5 lists some typical examples.

Table 18-5. Typical PSoC Block Configurations

Configuration	Description	Sign
SAR6 – 2 blocks	1 DAC6, 1 COMP (could be CT)	0
SAR6 – 1 block	DAC6 and COMP in 1 block	1
MS SAR10 – 3 blocks	1 DAC9, 1 COMP (could be CT) (when processing MS DAC block)	0

Bits 2 and 1: SARCOL[1:0]. These bits are the column select for the SAR comparator input. The DAC portion of the SAR can reside in any of the appropriate positions in the analog PSoC block array. However, once the COMPARATOR block is positioned (and it is possible to have the DAC and COMPARATOR in the same block), this position should be the column selected.

Bit 0: SYNCEN. This bit is to synchronize CPU data writes to Switched Capacitor (SC) block operation in the analog array. The SC block clock is selected in the CLK_CR0 register. The selected clock source is divided by four and the output is a pair of two-phase, non-overlapping clocks: PHI1 and PHI2. There is an optimal time, with respect to the PHI1 and PHI2 clocks, to change the capacitor configuration in the SC block, which is typically the rising edge of PHI1. This is normally the time when the input branch capacitor is charging.

When this bit is set, any write to an SC block register is stalled until the rising edge of the next PHI1 clock phase, for the column associated with the SC block address. The stalling operation is implemented by suspending the CPU clock. No CPU activity occurs during the stall, including interrupt processing. Therefore, the effect of stalling on CPU throughput must be considered.

For additional information, refer to the [ASY_CR register on page 182](#).

18.4.3 CMP_CR1 Register

Addr.	Name	Cols.	Bit 7	Bit 6	Bit 5	Bit 4	Bit 3	Bit 2	Bit 1	Bit 0	Access
0,66h	CMP_CR1	4	CLDIS[3]	CLDIS[2]	CLDIS[1]	CLDIS[0]					RW : 00
		2			CLDIS[1]	CLDIS[0]			CLK1X[1]	CLK1X[0]	
		1			CLDIS[1]						

The Analog Comparator Bus Register 1 (CMP_CR1) is used to override the analog column comparator synchronization.

Bits 7 to 4: CLDIS[x]. When these bits are set, the given column is not synchronized to PHI2 in the analog interface. This capability is typically used to allow a continuous time comparator result to propagate directly to the interrupt controller during sleep. Since the master clocks (except the 32 kHz clock) are turned off during sleep, the synchronizer must be bypassed.

Bits 1 and 0: CLK1X[1:0]. These bits are only used by the CY8C24x94 and CY7C64215 PSoC devices. When these bits are set for a given column, the analog comparator synchronization is implemented using the direct 1X column clock, rather than the divide by 4 PHI2 clock. This allows for high frequency comparator sampling.

For additional information, refer to the [CMP_CR1 register on page 183](#).

18.4.4 DEC_CR0 Register

Addr.	Name	Cols.	Bit 7	Bit 6	Bit 5	Bit 4	Bit 3	Bit 2	Bit 1	Bit 0	Access
0,E6h	DEC_CR0	4, 2	IGEN[3:0]				ICLKS0	DCOL[1:0]		DCLKS0	RW : 00

The Decimator Control Register 0 (DEC_CR0) contains control bits to access hardware support for both the Incremental ADC and the DELSIG ADC.

This register can only be used with four and two analog column PSoC devices.

Bits 7 to 4: IGEN[3:0]. For incremental support, these bits select which column comparator bit will be gated by the output of a digital block. The output of that digital block is typically a PWM signal; the high time of which corresponds to the ADC conversion period. This ensures that the comparator output is only processed for the precise conversion time. The digital block selected for the gating function is controlled by ICLKS0 in this register, and ICLKS3, ICLKS2 and ICLKS1 bits in the DEC_CR1 register.

Bit 3: ICLKS0. In conjunction with ICLKS1, ICLKS2, and ICLKS3 in the DEC_CR1 register, these bits select up to one of 16 digital blocks (depending on the PSoC device resources) to provide the gating signal for an incremental ADC conversion.

Bits 2 and 1: DCOL[1:0]. The DELSIG ADC uses the hardware decimator to do a portion of the post processing computation on the comparator signal. DCOL[1:0] selects the column source for the decimator data (comparator bit) and clock input (PHI clocks).

Bit 0: DCLKS0. The decimator requires a timer signal to sample the current decimator value to an output register that may subsequently be read by the CPU. This timer period is set to be a function of the DELSIG conversion time and may be selected from up to one of eight digital blocks (depending on the PSoC device resources) with DCLKS0 in this register and DCLKS3, DCLKS2, and DCLKS1 in the DEC_CR1 register.

For additional information, refer to the [DEC_CR0 register on page 245](#).

18.4.5 DEC_CR1 Register

Address	Name	Cols.	Bit 7	Bit 6	Bit 5	Bit 4	Bit 3	Bit 2	Bit 1	Bit 0	Access
0,E7h	DEC_CR1	4		IDEC	ICLKS3	ICLKS2	ICLKS1	DCLKS3	DCLKS2	DCLKS1	RW : 00
		2	ECNT	IDEC	ICLKS3	ICLKS2	ICLKS1	DCLKS3	DCLKS2	DCLKS1	RW : 00

The Decimator Control Register 1 (DEC_CR1) is used to

configure the decimator prior to using it.

This register can only be used with four and two analog column PSoC devices.

Depending on how many analog columns your PSoC device has (see the Cols. column in the register table above), only certain bits are accessible to be read or written.

Bit 7: ECNT. The ECNT bit is a mode bit that controls the operation of the decimator hardware block. By default, the decimator is set to a double integrate function, for use in hardware DELSIG processing. When the ECNT bit is set, the decimator block converts to a single integrate function. This gives the equivalent of a 16-bit counter suitable for use in hardware support for an Incremental ADC function.

The DEC_CR1 register's bit 7 (ECNT) is only available in PSoC devices with a type 1 decimator and is reserved in PSoC devices with a type 2 decimator. Refer to the table titled "Decimator Availability for PSoC Devices" on page 475

to determine which type of decimator your PSoC device uses.

Bit 6: IDEC. Any function using the decimator requires a digital block timer to sample the current decimator value. Normally, the positive edge of this signal causes the decimator output to be sampled. However, when the IDEC bit is set, the negative edge of the selected digital block input causes the decimator value to be sampled.

Bits 5 to 0: ICLKSx and DCLKSx. The ICLKS3, ICLKS2, ICLKS1, DCLKS3, DCLKS2, and DCLKS1 bits in this register select the digital block sources for Incremental and DEL-SIGN ADC hardware support (see the DEC_CR0 register).

For additional information, refer to the [DEC_CR1 register on page 247](#).

18.4.6 CLK_CR0 Register

Add.	Name	Cols.	Bit 7	Bit 6	Bit 5	Bit 4	Bit 3	Bit 2	Bit 1	Bit 0	Access
1,60h	CLK_CR0	4	AColumn3[1:0]		AColumn2[1:0]		AColumn1[1:0]		AColumn0[1:0]		RW : 00
		2					AColumn1[1:0]		AColumn0[1:0]		
		1					AColumn1[1:0]				

The Analog Clock Source Control Register 0 (CLK_CR0) is used to select the clock source for an individual analog column.

An analog column clock generator is provided for each column. The bits in this register select the source for each column clock generator, depending on how many analog columns are supported in your PSoC device. Regardless of the source selected, the input clock is divided by four to generate the PHI1/PHI2 non-overlapping clocks for the column.

There are four selections for each clock: VC1, VC2, ACLK0, and ACLK1. VC1 and VC2 are the programmable global system clocks. ACLK0 and ACLK1 sources are each selected from up to one of eight digital block outputs (functioning as clock generators), for four and two analog column devices, and up to one of four digital block outputs (functioning as clock generators), for one analog column device as selected by CLK_CR1.

Bits 7 and 6: AColumn3[1:0]. These bits select the source for analog column 3.

Bits 5 and 4: AColumn2[1:0]. These bits select the source for analog column 2.

Bits 3 and 2: AColumn1[1:0]. These bits select the source for analog column 1.

Bits 1 and 0: AColumn0[1:0]. These bits select the source for analog column 0.

For additional information, refer to the [CLK_CR0 register on page 265](#).

18.4.7 CLK_CR1 Register

Add.	Name	Cols.	Bit 7	Bit 6	Bit 5	Bit 4	Bit 3	Bit 2	Bit 1	Bit 0	Access
1,61h	CLK_CR1	4, 2		SHDIS	ACLK1[2:0]			ACLK0[2:0]			RW : 00

The Analog Clock Source Control Register 1 (CLK_CR1) is used to select the clock source for an individual analog column.

This register can only be used with four and two column PSoC devices.

Bit 6: SHDIS. The SHDIS bit functions as follows. During normal operation of an SC block, for the amplifier of a column enabled to drive the output bus, the connection is only made for the last half of PHI2. (During PHI1 and for the first half of PHI2, the output bus floats at the last voltage to which it was driven.) This forms a sample and hold operation using the output bus and its associated *capacitance*. This design prevents the output bus from being perturbed by the intermediate states of the SC operation (often a reset state for PHI1 and settling to the valid state during PHI2).

The following are the exceptions: 1) If the ClockPhase bit in ASCxx_CR0 (for the SC block in question) is set to '1', then the output is enabled if the analog bus output is enabled during both PHI1 and PHI2. 2) If the SHDIS signal is set in bit 6 of the Analog Clock Source Control register, then sample and hold operation is disabled for all columns and all enabled outputs of SC blocks are connected to their respective output buses, for the entire period of their respective PHI2s.

Bits 5 to 0: ACLKx[2:0]. There are two 3-bit fields in this register that can select up to one of eight digital blocks (depending on the PSoC device resources), to function as the clock source for ACLK0 and ACLK1. ACLK0 and ACLK1 are alternative clock inputs to the analog column clock generators (see the CLK_CR0 register above).

For additional information, refer to the [CLK_CR1 register on page 266](#).

18.4.8 AMD_CR0 Register

Addr.	Name	Cols.	Bit 7	Bit 6	Bit 5	Bit 4	Bit 3	Bit 2	Bit 1	Bit 0	Access
1,63h	AMD_CR0	4		AMOD2[2:0]				AMOD0[2:0]			RW : 00
		2							AMOD0[2:0]		

The Analog Modulation Control Register 0 (AMD_CR0) is used to select the modulator bits used with each column.

This register can only be used with four and two column PSoC devices.

The MODBIT is an input into an Switched Capacitor C Type block only and is XOR'ed with the currently programmed value of the ASIGN bit in the CR0 register for that SC block. This allows the ACAP sign bit to be dynamically modulated by hardware signals. Three bits for each column allow a one of eight selection for the MODBIT. Sources include any of the analog column comparator buses, two global buses, and one broadcast bus. The default for this function is zero or off.

Note that in the CY8C21x34, CY8C21x23, CY7C603xx, and CYWUSB6953 PSoC devices the ACAP sign bit is not implemented on the SC blocks.

Bits 6 to 4: AMOD2[2:0]. These bits control the selection of the MODBITS for analog column 2.

Bits 2 to 0: AMOD0[2:0]. These bits control the selection of the MODBITS for analog column 0.

For additional information, refer to the [AMD_CR0 register on page 269](#).

18.4.9 CMP_GO_EN Register

Address	Name	Bit 7	Bit 6	Bit 5	Bit 4	Bit 3	Bit 2	Bit 1	Bit 0	Access
1,64h	CMP_GO_EN	GOO5	GOO1	SEL1[1:0]		GOO4	GOO0	SEL0[1:0]		RW : 00

The Comparator Bus to Global Outputs Enable Register (CMP_GO_EN) controls options for driving the analog comparator bus and column clock to the global bus.

This register is only used by the CY8C24x94, CY8C21x34, CY8C21x23, CY7C64215, CY7C603xx, and CYWUSB6953 PSoC devices.

Bit 7: GOO5. This bit drives the selected column 1 signal to GOO5.

Bit 6: GOO1. This bit drives the selected column 1 signal to GOO1.

Bits 5 and 4: SEL1[1:0]. These bits select the column 1 signal to output.

Bit 3: GOO4. This bit drives the selected column 0 signal to GOO4.

Bit 2: GOO0. This bit drives the selected column 0 signal to GOO0.

Bits 1 and 0: SEL0[1:0]. These bits select the column 0 signal to output.

For additional information, refer to the [CMP_GO_EN register on page 271](#).

18.4.10 CMP_GO_EN1 Register

Address	Name	Bit 7	Bit 6	Bit 5	Bit 4	Bit 3	Bit 2	Bit 1	Bit 0	Access
1,65h	CMP_GO_EN1	GOO7	GOO3	SEL3[1:0]		GOO6	GOO2	SEL2[1:0]		RW : 00

The Comparator Bus to Global Outputs Enable Register 1 (CMP_GO_EN1) controls options for driving the analog comparator bus and column clock to the global bus.

This register is only used by the CY8C24x94 and CY7C64215 PSoC devices.

Bit 7: GOO7. This bit drives the selected column 3 signal to GOO7.

Bit 6: GOO3. This bit drives the selected column 3 signal to GOO3.

Bits 5 and 4: SEL3[1:0]. These bits select the column 3 signal to output.

Bit 3: GOO6. This bit drives the selected column 2 signal to GOO6.

Bit 2: GOO2. This bit drives the selected column 2 signal to GOO2.

Bits 1 and 0: SEL2[1:0]. These bits select the column 2 signal to output.

For additional information, refer to the [CMP_GO_EN1 register on page 272](#).

18.4.11 AMD_CR1 Register

Add.	Name	Cols.	Bit 7	Bit 6	Bit 5	Bit 4	Bit 3	Bit 2	Bit 1	Bit 0	Access
1,66h	AMD_CR1	4		AMOD3[2:0]				AMOD1[2:0]			RW : 00
		2							AMOD1[2:0]		

The Analog Modulation Control Register 1 (AMD_CR1) is used to select the modulator bits used with each column.

This register can only be used with four and two column PSoC devices.

The MODBIT is an input into an Switched Capacitor Type C block only and is XOR'ed with the currently programmed value of the ASIGN bit in the CR0 register for that SC block. This allows the ACAP sign bit to be dynamically modulated by hardware signals. Three bits for each column allow a one of eight selection for the MODBIT. Sources include any of the analog column comparator buses, two global buses, and one broadcast bus. The default for this function is zero or off.

Note that in the CY8C21x34, CY8C21x23, CY7C603xx, and CYWUSB6953 PSoC devices the ACAP sign bit is not implemented on the SC blocks.

Bits 6 to 4: AMOD3[2:0]. These bits control the selection of the MODBITs for analog column 3.

Bits 2 to 0: AMOD1[2:0]. These bits control the selection of the MODBITs for analog column 1.

For additional information, refer to the [AMD_CR1 register on page 273](#).

18.4.12 ALT_CR0 Register

Add.	Name	Cols.	Bit 7	Bit 6	Bit 5	Bit 4	Bit 3	Bit 2	Bit 1	Bit 0	Access
1,67h	ALT_CR0	4, 2	LUT1[3:0]				LUT0[3:0]				RW : 00
		1	LUT1[3:0]								

The Analog LUT Control Register 0 (ALT_CR0) is used to select the logic function.

A one of 16 look-up table (LUT) is applied to the outputs of each column comparator bit and optionally a neighbor bit to implement two input logic functions.

Table 18-1 shows the available functions, where the A input applies to the selected column and the B input applies to the next most significant neighbor column. Column 0 settings apply to combinations of column 0 and column 1. Column 1 settings apply to combinations of column 1 and column 2, where B=0 for one column PSoC devices.

Bits 7 to 4: LUT1[3:0]. These bits control the selection of the LUT 1 logic functions that may be selected for the analog comparator bits in column 0 (for two and four column PSoC devices only) and column 1.

Bits 3 to 0: LUT0[3:0]. These bits control the selection of LUT 0 logic functions that may be selected for the analog comparator bits in column 0 (for two and four column PSoC devices only) and column 1.

For additional information, refer to the [ALT_CR0 register on page 275](#).

18.4.13 ALT_CR1 Register

Add.	Name	Cols.	Bit 7	Bit 6	Bit 5	Bit 4	Bit 3	Bit 2	Bit 1	Bit 0	Access
1,68h	ALT_CR1	4	LUT3[3:0]				LUT2[3:0]				RW : 00

The Analog LUT Control Register 1 (ALT_CR1) is used to select the logic function performed by the LUT for each analog column.

This register can only be used with four column PSoC devices.

Bits 7 to 4: LUT3[3:0]. These bits control the selection of the LUT 3 logic functions that may be selected for the analog comparator bits.

Bits 3 to 0: LUT2[3:0]. These bits control the selection of LUT 2 logic functions that may be selected for the analog comparator bits.

For additional information, refer to the [ALT_CR1 register on page 277](#).

18.4.14 CLK_CR2 Register

Addr.	Name	Cols.	Bit 7	Bit 6	Bit 5	Bit 4	Bit 3	Bit 2	Bit 1	Bit 0	Access
1,69h	CLK_CR2	4					ACLK1R			ACLK0R	RW : 00

The Analog Clock Source Control Register 2 (CLK_CR2), in conjunction with the CLK_CR1 and CLK_CR0 registers, selects a digital block as a source for analog column clocking.

This register can only be used with four column PSoC devices.

Bit 3: ACLK1R. This bit selects bank one of eight digital blocks and is only used in devices with more than eight digital blocks.

Bit 0: ACLK0R. This bit selects bank zero of eight digital blocks and is only used in devices with more than eight digital blocks.

For additional information, refer to the [CLK_CR2 register on page 278](#).

19. Analog Array



This chapter presents the Analog Array, which has no registers directly associated with it. This chapter is important because it discusses the block and column level interconnects that exist in the analog PSoC array. For information on the analog array for the CY8C21x34, CY8C21x23, CY7C603xx, and CYWUSB6953 PSoC devices, refer to the [Two Column Limited Analog System](#) chapter on page 431.

19.1 Architectural Description

The analog array is designed to allow interaction between PSoC devices without modifying projects, except for resource limitations.

Refer to the table at the beginning of the [Analog System](#) section, on page 371, to determine how many columns of analog PSoC blocks a particular PSoC device has. The figures that follow illustrate the analog multiplexer (mux) connections for the various PSoC devices, which vary depending on column availability.

Figure 19-1 displays the various analog arrays, depending on the column configuration of the PSoC device. Each analog column has 3 analog blocks associated with it. In the figures throughout this chapter, shading and call outs portray the different column configurations that are available in a PSoC device.

Note The CY8C21x34, CY8C21x23, CY7C603xx, and CYWUSB6953 PSoC devices have limited analog array functionality. The only analog array connections available to these devices are the NMux and PMux connections. See the [Two Column Limited Analog System](#) chapter on page 431 for more information.

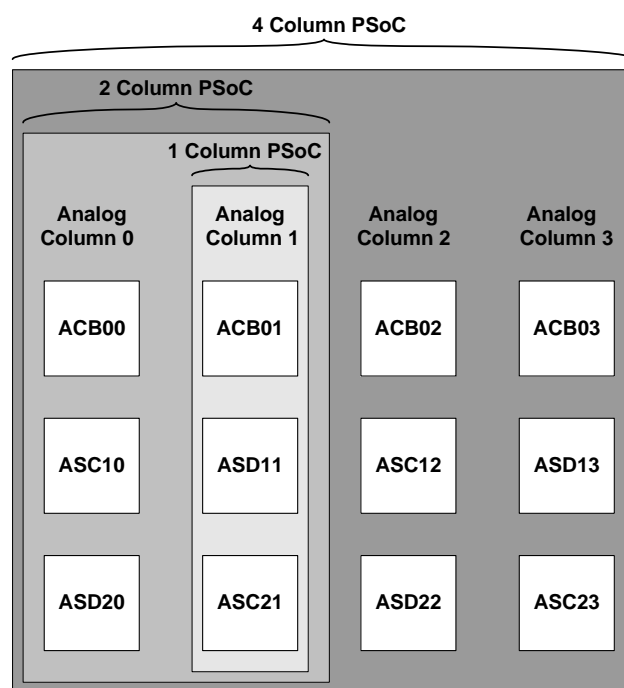

Figure 19-1. Array of Analog PSoC Blocks

19.1.1 NMux Connections

The NMux is an 8-to-1 mux which determines the source for the inverting (also called negative) input of Continuous Time PSoC blocks. These blocks are named ACB00, ACB01, ACB02, and ACB03. More details on the Continuous Time PSoC blocks are available in the chapter [Continuous Time PSoC Block](#), on page 415. The NMux connections are described in detail in the [ACBxxCR1 register](#) on page 190, bits NMux[2:0].

The numbers in [Figure 19-2](#), which are associated with each arrow, are the corresponding NMux select line values for the data in the NMux portion of the register. The call out names in the figure show nets selected for each NMux value.

For one column PSoC devices, the figure view is expanded in a circular area to the left of the main diagram, where black call outs and arrows signify exclusive one column functionality and gray call outs and arrows signify commonality with four and two column PSoC devices.

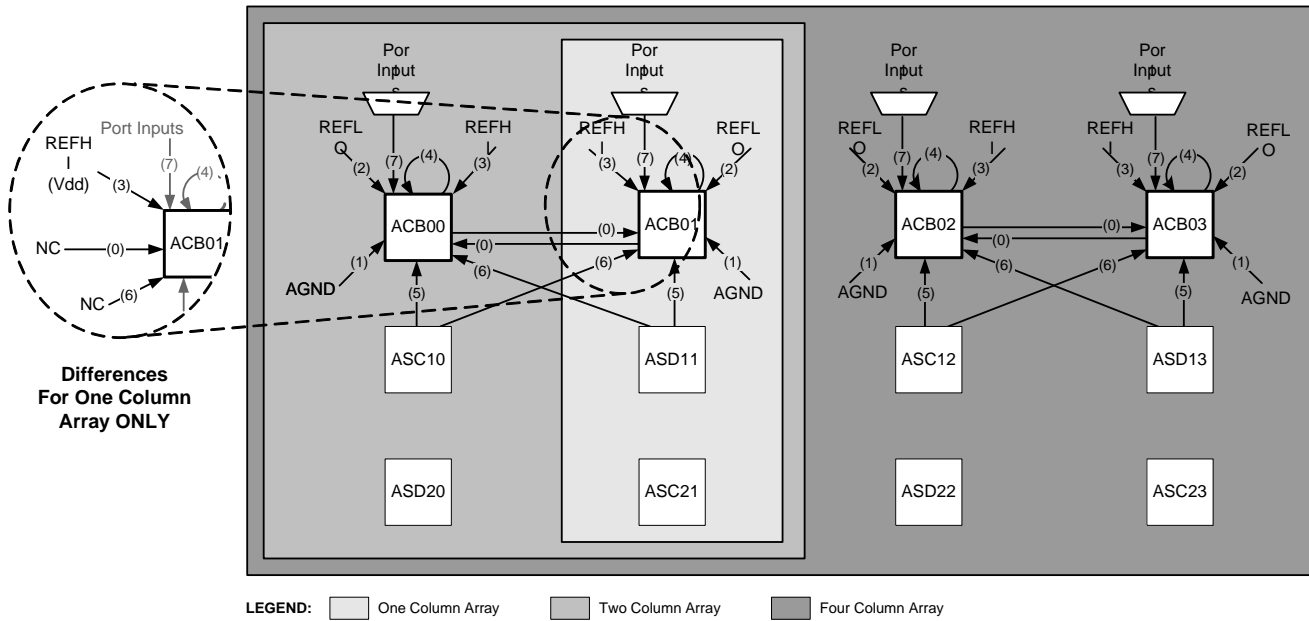

Figure 19-2. NMux Connections

19.1.2 PMux Connections

The PMux is an 8-to-1 mux which determines the source for the non-inverting (also called positive) input of Continuous Time PSoC blocks. These blocks are named ACB00, ACB01, ACB02, and ACB03. More details on the Continuous Time PSoC blocks are available in the chapter [Continuous Time PSoC Block](#), on page 415. The PMux connections are described in detail in the [ACBxxCR1 register](#) on page 190, bits PMux[2:0].

The numbers in [Figure 19-3](#), which are associated with each arrow, are the corresponding PMux select line values for the data in the PMux portion of the register. The call out names in the figure show nets selected for each PMux value.

For one column PSoC devices, the figure view is expanded in a circular area to the left of the main diagram, where black call outs and arrows signify exclusive one column functionality, and gray call outs and arrows signify commonality with four and two column PSoC devices.

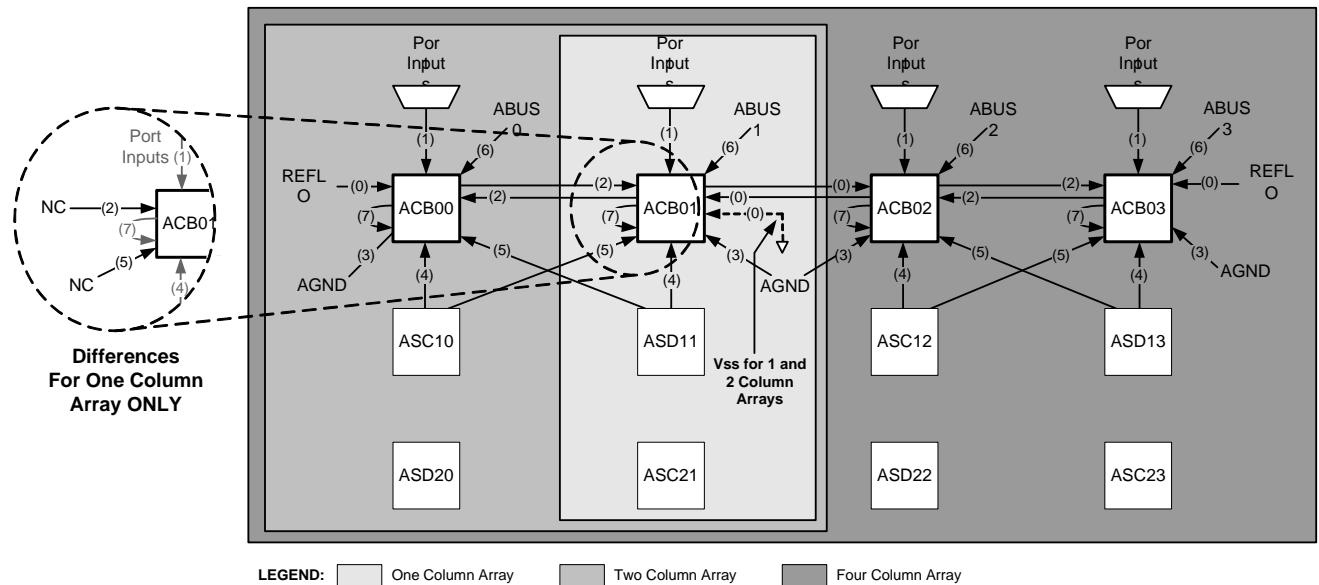

Figure 19-3. PMux Connections

19.1.3 RBotMux Connections

The RBotMux connections in the figure below are the mux inputs for the bottom of the resistor string, see [Figure 22-1 on page 416](#). The RBotMux connections are used in the Continuous Time PSoC blocks. These blocks are named ACB00, ACB01, ACB02, and ACB03. The RBotMux connections are described in detail in the [ACBxxCR0 register on page 188](#), bits RBotMux[1:0].

The numbers in [Figure 19-4](#), which are associated with each arrow, are the corresponding RBotMux select line values for the data in the RBotMux portion of the register. The call out names in the figure show nets selected for each RBotMux value.

The logic statements in [Figure 19-4](#) are the RBotMux connections that are selected by the combination of the RBotMux bits (ACB0xCR0 bits 1 and 0) and the INSAMP bit

(ACB0xCR3 bit 1). For example, the RBotMux selects a connection to AGND, if the INSAMP bit is low and the RBotMux bits are 01b. This is shown in the figure as the logic statement $\overline{INSAMP} \cdot (RB = 1)$.

For one column PSoC devices, the figure view is expanded in a circular area to the left of the main diagram, where black call outs and arrows signify exclusive one column functionality, and gray call outs and arrows signify commonality with four and two column PSoC devices.

Note The RBotMux connections are not available to the CY8C21x34, CY8C21x23, CY7C603xx, and CYWUSB6953 PSoC devices. See the [Two Column Limited Analog System chapter on page 431](#).

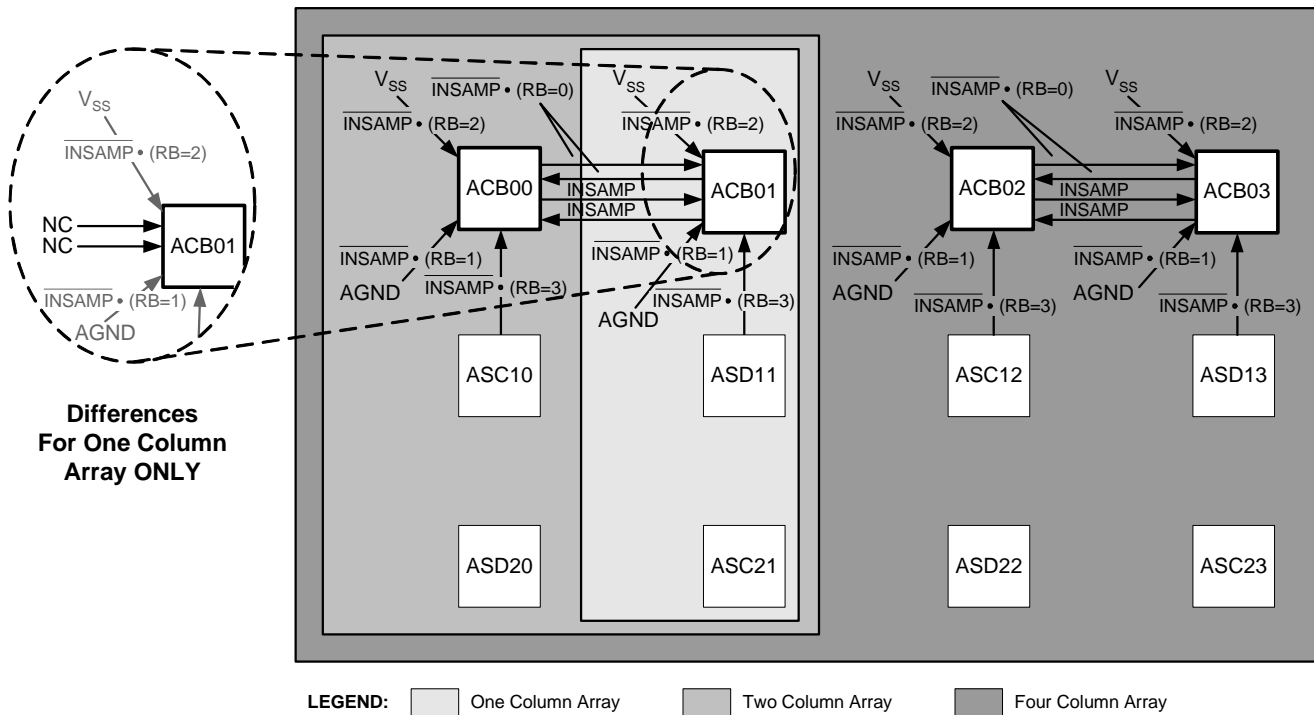

Figure 19-4. RBotMux Connections

19.1.4 AMux Connections

The AMux connections in the figure below are the mux inputs for controlling both the A and C capacitor branches. The high order bit, ACMux[2], selects one of two inputs for the C branch, which is used to control both the AMux and CMux. (See the A inputs in [Figure 23-1 on page 422](#) and [Figure 23-2 on page 423](#).) The AMux connections are used in the Switched Capacitor PSoc blocks. These blocks are named ASC10, ASD11, ASC12, ASD13, ASD20, ASC21, ASD22, and ASC23. The AMux connections are described in detail in the [ASCxxCR1 register on page 197](#), bits ACMux[2:0], and [ASDxxCR1 register on page 201](#), bits AMux[2:0].

The numbers in [Figure 19-5](#), which are associated with each arrow, are the corresponding AMux select line values for the

data in the ACMux portion of the register. The call out names in the figure show nets selected for each AMux value.

For one column PSoc devices, the figure view is expanded in a circular area to the left of the main diagram, where black call outs and arrows signify exclusive one column functionality, and gray call outs and arrows signify commonality with four and two column PSoc devices.

Note The AMux connections are not available to the CY8C21x34, CY8C21x23, CY7C603xx, and CYWUSB6953 PSoc devices. See the [Two Column Limited Analog System chapter on page 431](#).

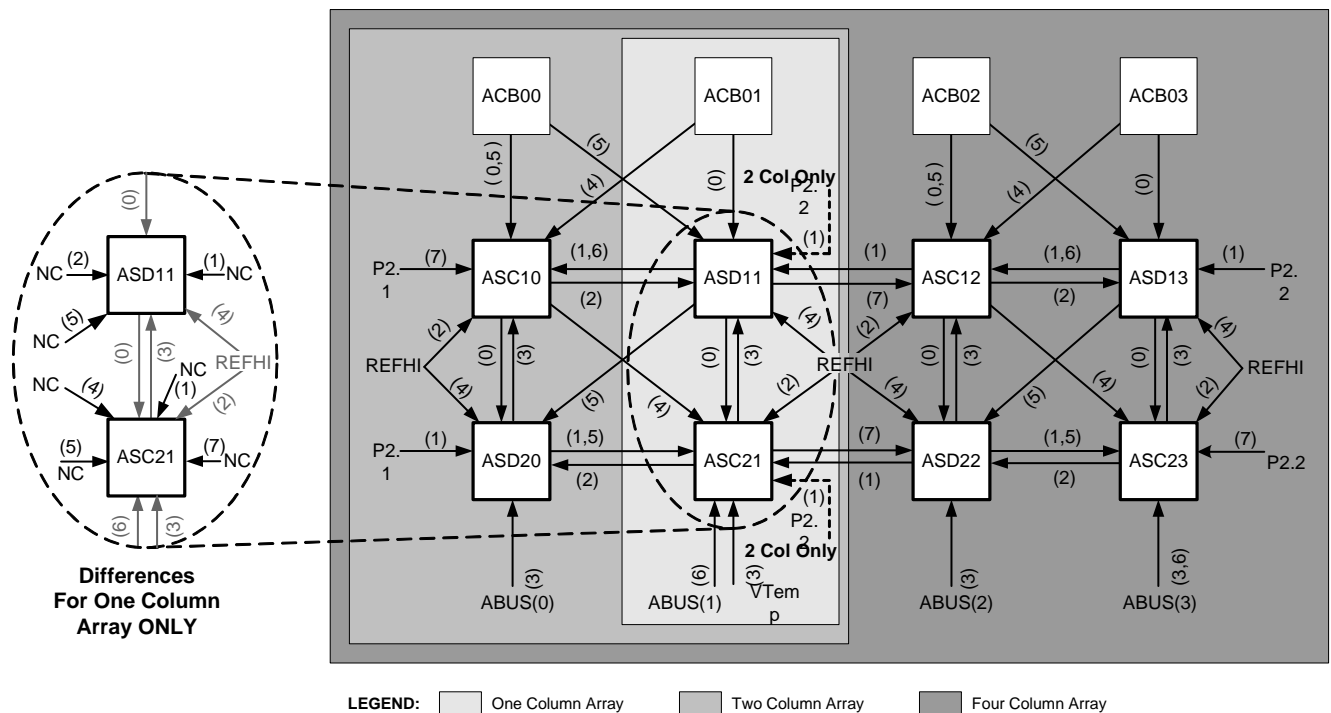

Figure 19-5. AMux Connections

19.1.5 CMux Connections

The CMux connections in the figure below are the mux inputs for controlling the C capacitor branches. The high order bit, ACMux[2], selects one of two inputs for the C branch, which is used to control both the AMux and CMux. (See the C inputs in [Figure 23-1 on page 422.](#)) The CMux connections are used in the Switched Capacitor PSoC blocks. These blocks are named ASC10, ASC21, ASC12, and ASC23.

The CMux connections are described in detail in the [ASCxxCR1 register on page 197](#), bits ACMux[2:0]. The

numbers in the figure, which are associated with each arrow, are the corresponding CMux select line values for the data in the CMux portion of the register. The call out names in the figure show nets selected for each CMux value.

Note The CMux connections are not available to the CY8C21x34, CY8C21x23, CY7C603xx, and CYWUSB6953 PSoC devices. See the [Two Column Limited Analog System chapter on page 431.](#)

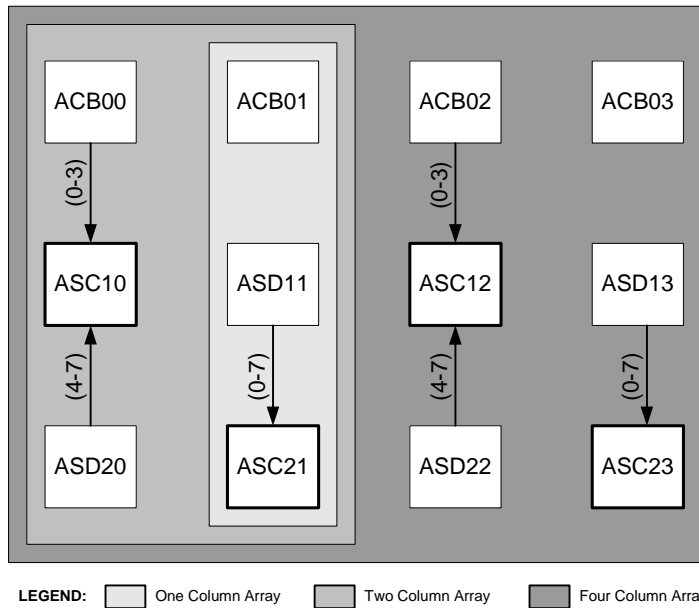

Figure 19-6. CMux Connections

19.1.6 BMux SC/SD Connections

The BMux SC/SD connections in the figure below are the mux inputs for controlling the B capacitor branches. (See [Figure 23-1 on page 422](#) and [Figure 23-2 on page 423](#).) The BMux SC/SD connections are used in the Switched Capacitor PSoC blocks. These blocks are named ASC10, ASD11, ASC12, ASD13, ASD20, ASC21, ASD22, and ASC23. The BMux connections are described in detail in the [ASCxxCR3 register on page 199](#), bits BMuxSC[1:0], and [ASDxxCR3 register on page 203](#), bit BMuxSD[2].

The numbers in [Figure 19-7](#), which are associated with each arrow, are the corresponding BMux select line values for the

data in the BMux portion of the register. The call out names in the figure show nets selected for each BMux value.

For one column PSoC devices, the figure view is expanded in a circular area to the left of the main diagram, where black call outs and arrows signify exclusive one column functionality, and gray call outs and arrows signify commonality with four and two column PSoC devices.

Note The BMux SC/SD connections are not available to the CY8C21x34, CY8C21x23, CY7C603xx, and CYWUSB6953 PSoC devices. See the [Two Column Limited Analog System chapter on page 431](#).

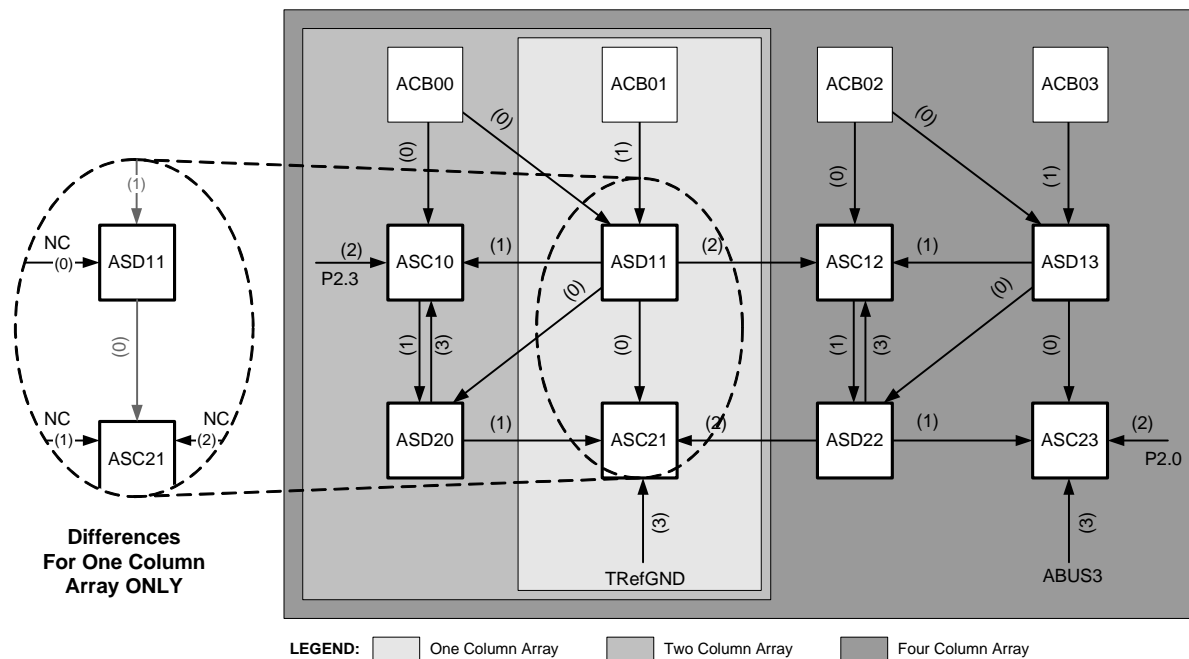

Figure 19-7. BMux SC/SD Connections

19.1.7 Analog Comparator Bus

Each analog column has a dedicated comparator bus associated with it. Every analog PSoC block has a comparator output that can drive out on this bus. However, the comparator output from only one analog block in a column can be actively driving the comparator bus for that column at any one time. Refer to the [“Analog Comparator Bus Interface” on page 378](#) in the Analog Interface chapter for more information. Refer to the [“Analog Comparator Bus Interface” on page 432](#) for information on the analog comparator bus for the CY8C21x34, CY8C21x23, CY7C603xx, and CYWUSB6953 PSoC devices.

19.2 Temperature Sensing Capability

A temperature-sensitive voltage, derived from the bandgap sensing on the die, is buffered and available as an analog input into the Analog Switch Cap Type C block ASC21. Temperature sensing allows protection of device operating ranges for fail-safe applications. Temperature sensing, combined with a long sleep timer interval (to allow the die to approximate **ambient temperature**), can give an approximate ambient temperature for data acquisition and battery charging applications. The user may also calibrate the internal temperature rise based on a known current consumption. The temperature sensor input to the ASC21 block is labeled VTemp and its associated ground reference is labeled TRefGND.

20. Analog Input Configuration



This chapter discusses the Analog Input Configuration and its associated registers. For information on the analog input configuration for the CY8C21x34, CY8C21x23, CY7C603xx, and CYWUSB6953 PSoC devices, refer to the [Two Column Limited Analog System chapter on page 431](#). For a complete table of analog input configuration registers, refer to the “[Summary Table of the Analog Registers](#)” on page 373. For a quick reference of all PSoC registers in address order, refer to the [Register Details chapter on page 147](#).

20.1 Architectural Description

Depending on which PSoC device you have (1 column, 2 column, or 4 column), you will use one of the three analog input configuration and arrays as illustrated with three different shaded areas in [Figure 20-1](#). Note that the CY8C21x34, CY8C21x23, CY7C603xx, and CYWUSB6953 PSoC devices have two column limited functionality and no output drivers; therefore, a separate two column illustration and description has been created in the [Two Column Limited Analog System chapter on page 431](#).

[Figure 20-2](#), [Figure 20-3](#), and [Figure 20-5](#) present a more detailed view of each analog column configuration, along with their analog driver and pin specifics.

The input multiplexer (mux) maps device inputs (package pins) to analog array columns, based on bit values in the `AMX_IN` and `ABF_CR0` registers. Edge columns, in the four column configuration, are fed by one 4-to-1 mux; inner columns are fed by one of two 4-to-1 muxes. The muxes are **CMOS** switches with typical resistances in the range of 2K ohms.

Refer to the analog block diagrams, on the following pages, to view the various analog input configurations. For a four analog column device ([Figure 20-2](#)), the PSoC device has four analog drivers used to output analog values on port pins P0[5], P0[3], P0[4], and P0[2]. For a two analog column device ([Figure 20-3](#)), the PSoC device has two analog drivers used to output analog values on port pins P0[5] and P0[3]. For a one analog column device ([Figure 20-5](#)), the PSoC device has one analog driver used to output analog values on port pin P0[5]. Also in the figures that follow, depending on the pin configuration of your PSoC device, various shades of gray boxes are displayed denoting which port pins are associated with which pin parts.

Note that the one column PSoC device uses only one “internal” column (column 1) and has unique analog mux connectivity from Port 0 (8-to-1 into CT block). This device contains

a more limited reference block than the four and two column PSoC devices.

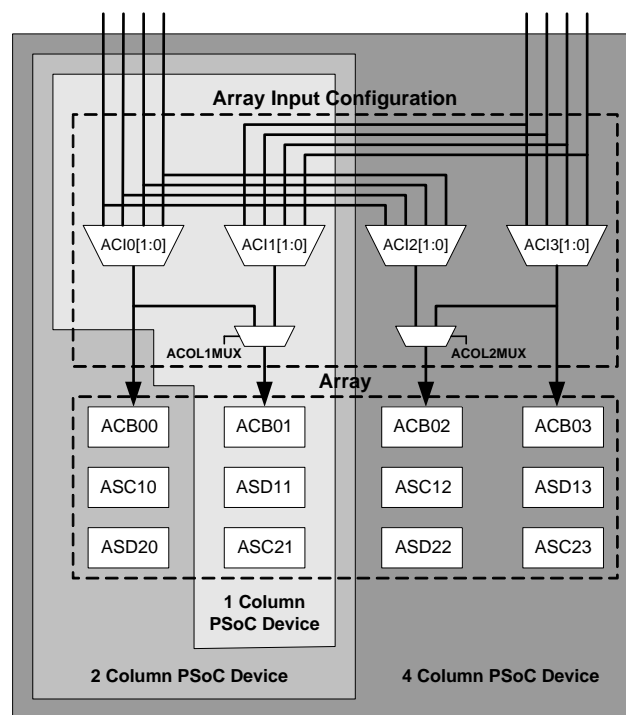

Figure 20-1. Analog Input Configuration Column Overview

20.1.1 Four Column Analog Input Configuration

The four column analog input configuration is detailed in Figure 20-2, along with the analog driver and pin specifics.

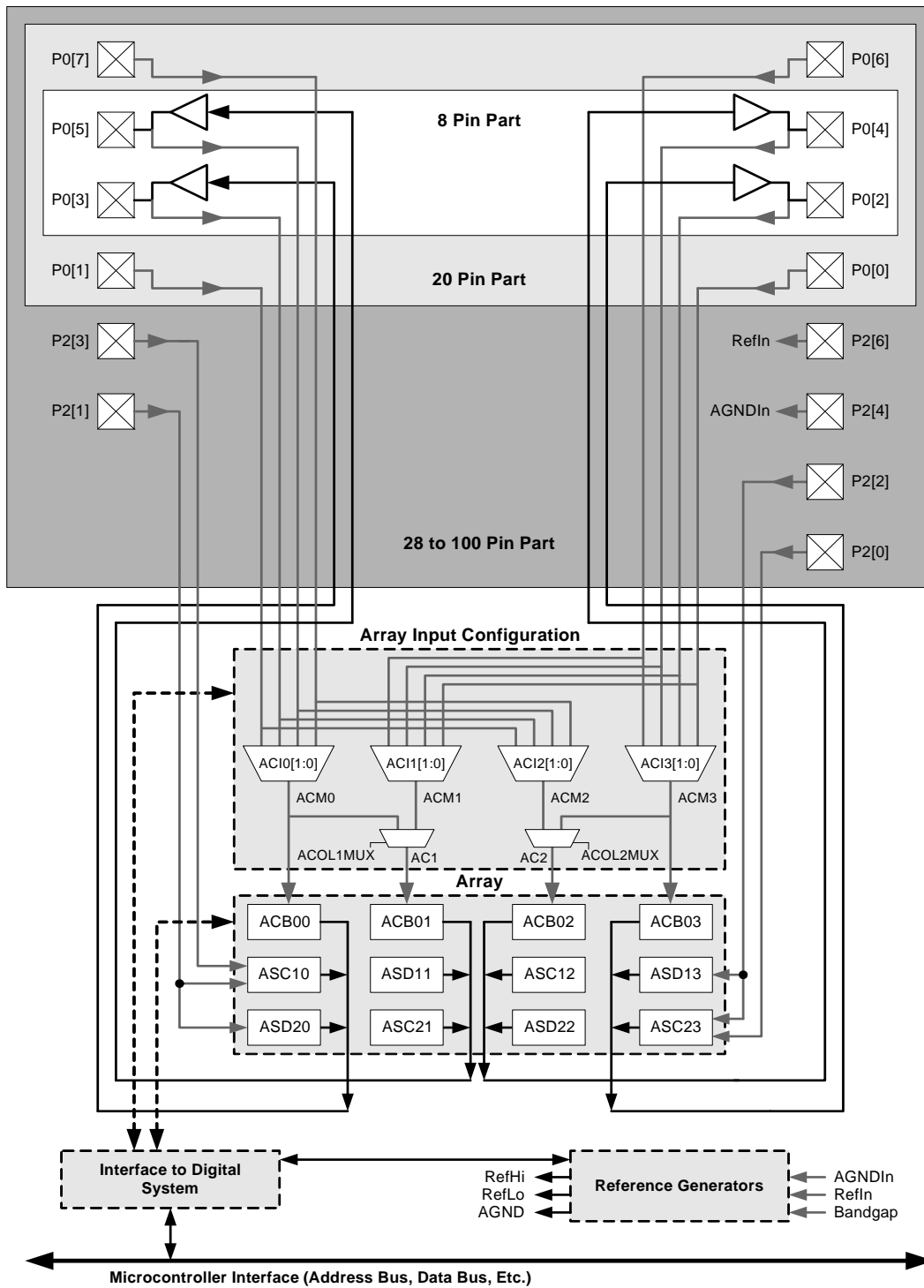

Figure 20-2. Four Column PSoC Analog Pin Block Diagram

20.1.2 Two Column Analog Input Configuration

The two column analog input configuration is detailed in [Figure 20-3](#), along with the analog driver and pin specifics. The two column analog input configuration for the USB CY8C24x94 and CY7C64215 PSoC devices is detailed in [Figure 20-4](#). For an illustration and description of the two column analog input configuration for the CY8C21x34, CY8C21x23, CY7C603xx, and CYWUSB6953 PSoC devices, refer to the [Two Column Limited Analog System](#) chapter on page 431.

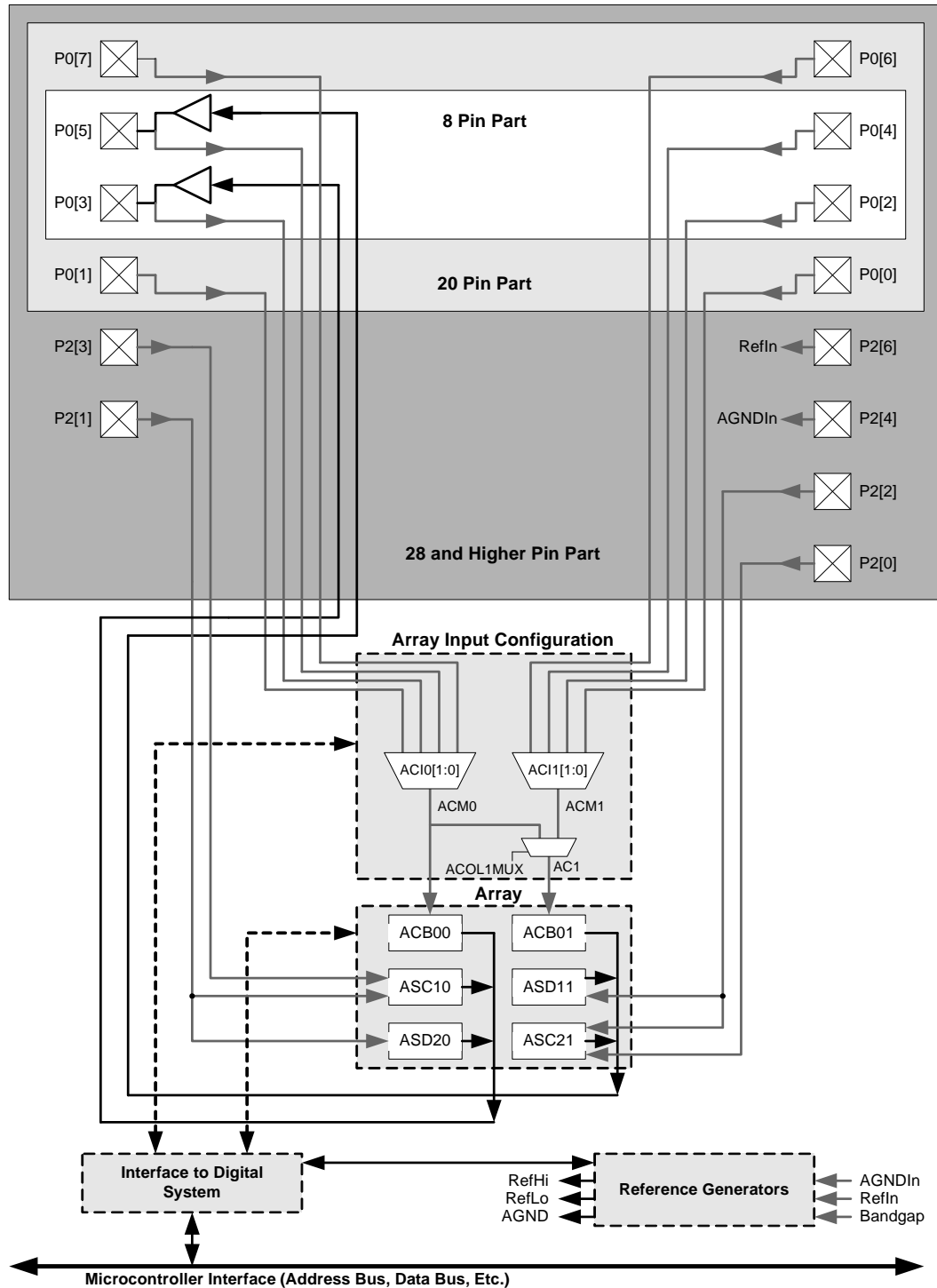

Figure 20-3. Two Column PSoC Analog Pin Block Diagram

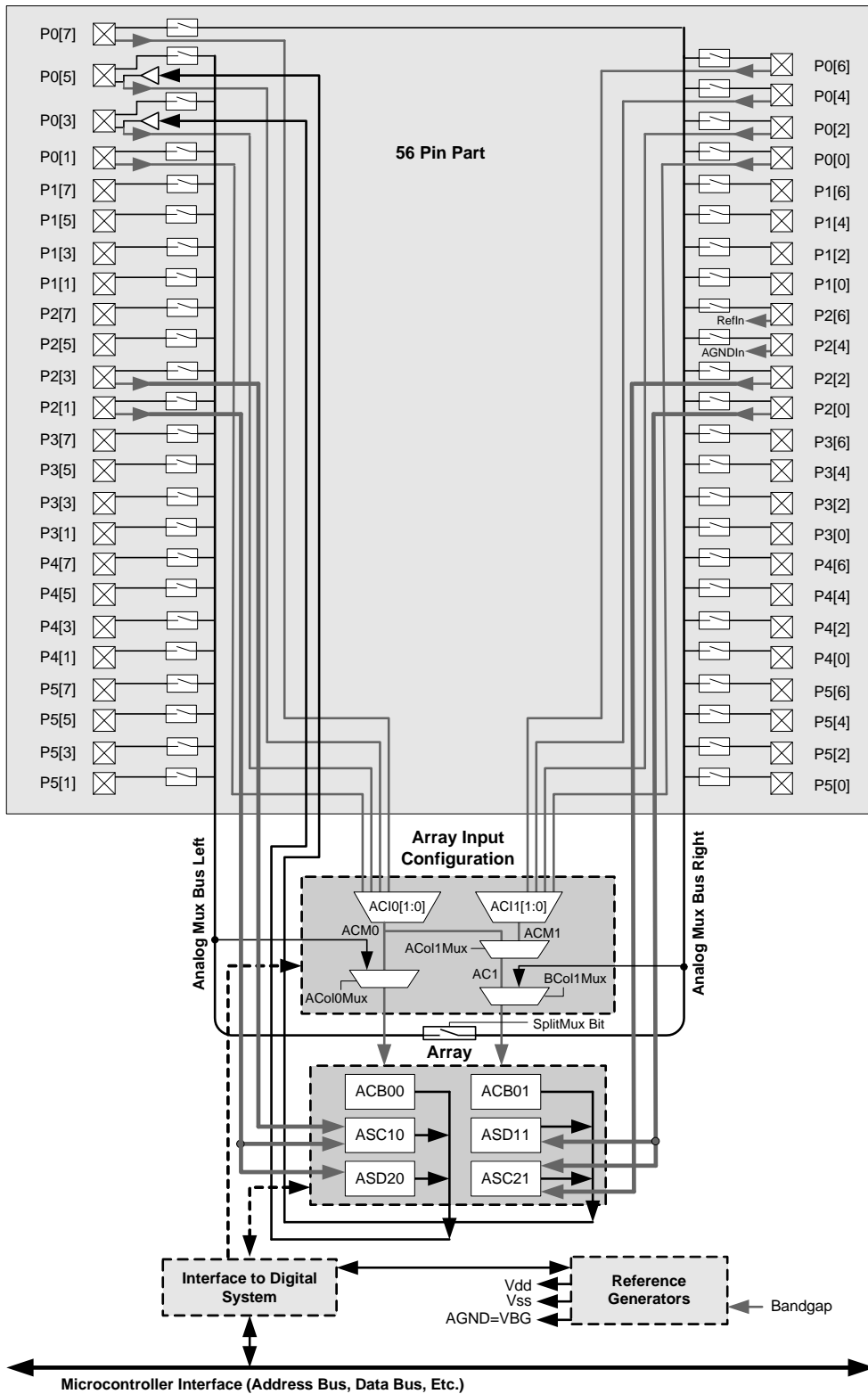

Figure 20-4. Two Column PSoC Analog Pin Block Diagram for USB

20.1.3 One Column Analog Input Configuration

The one column analog input configuration is detailed in Figure 20-5, along with the analog driver and pin specifics.

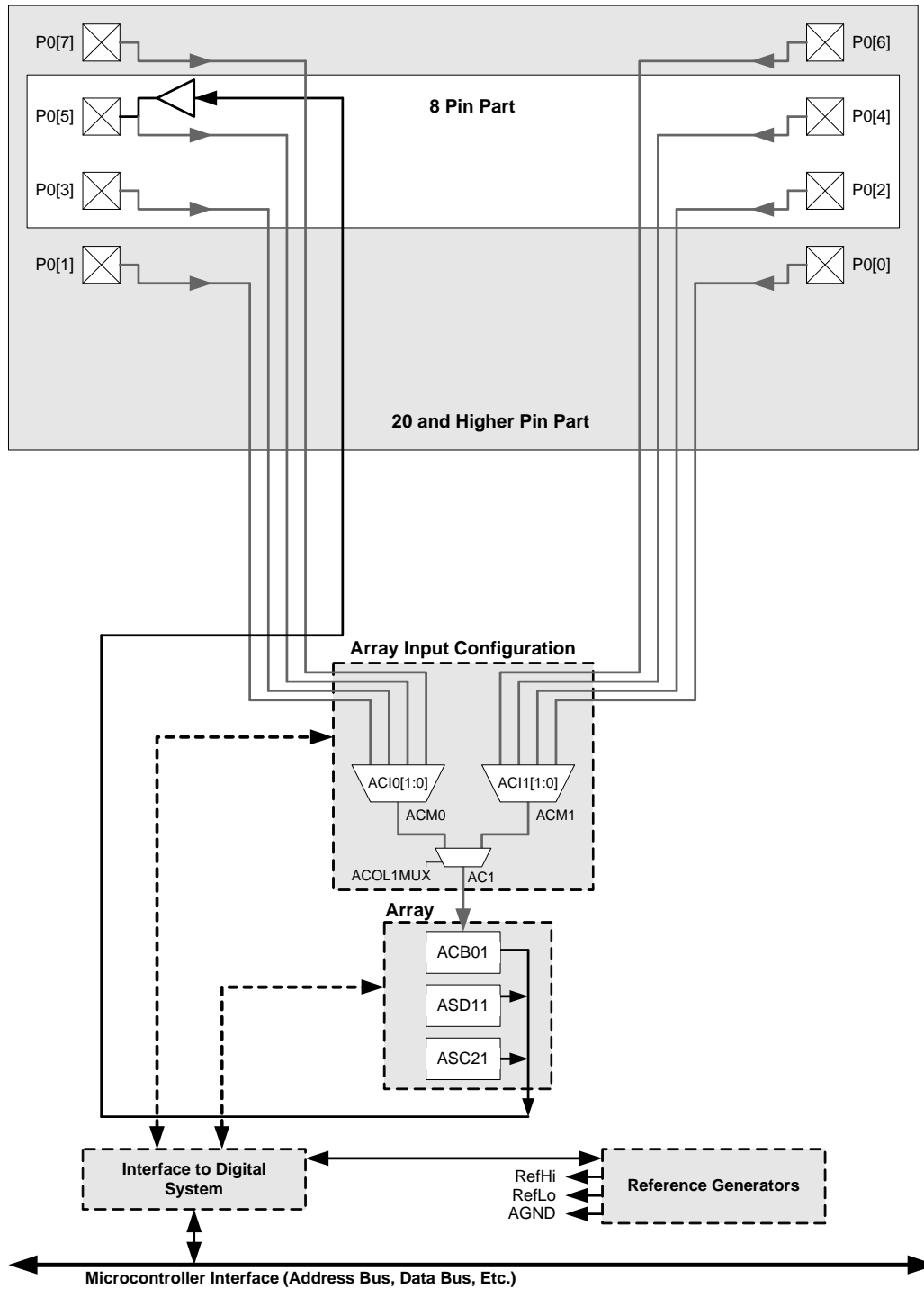

Figure 20-5. One Column PSoC Analog Pin Block Diagram

20.2 Register Definitions

The following registers are associated with Analog Input Configuration and are listed in address order. Each register description has an associated register table showing the bit structure for that register. Note that the analog input configuration register definitions for the CY8C21x34, CY8C21x23, CY7C603xx, and CYWUSB6953 PSoC devices are listed in the [Two Column Limited Analog System chapter on page 431](#). For a complete table of the analog input configuration registers, refer to the [“Summary Table of the Analog Registers” on page 373](#).

Depending on how many analog columns your PSoC device has (see the Cols. column in the register tables below), only certain bits are accessible to be read or written. The bits that are grayed out throughout this manual are reserved bits and are not detailed in the register descriptions that follow. Reserved bits should always be written with a value of '0'.

Note For the CY8C24x94 and CY7C64215 PSoC devices, refer to the [AMUX_CFG Register register on page 521](#) for information on bringing that device's analog mux bus into the analog array.

20.2.1 AMX_IN Register

Addr.	Name	Cols.	Bit 7	Bit 6	Bit 5	Bit 4	Bit 3	Bit 2	Bit 1	Bit 0	Access
0,60h	AMX_IN	4	ACI3[1:0]		ACI2[1:0]		ACI1[1:0]		ACI0[1:0]		RW : 00
		2					ACI1[1:0]		ACI0[1:0]		

The Analog Input Select Register (AMX_IN) controls the analog muxes that feed signals in from port pins into the analog column.

This register can only be used with four and two column PSoC devices.

Bits 7 to 0: ACIx[1:0].

For four column PSoC devices, each of the analog columns can have up to four port bits connected to its muxed input. Analog columns 1 and 2 (ACI1 and ACI2) have additional muxes that allow selection between separate column muxes. The ACol1Mux and ACol2Mux bit fields control the bits for those muxes and are located in the Analog Output Buffer Control register (ABF_CR0). There are up to four

additional analog inputs that go directly into the Switch Capacitor PSoC blocks.

For two column PSoC devices, the ACI1[1:0] and ACI0[1:0] bits control the analog muxes that feed signals in from port pins into the analog column. The analog column can have up to eight port bits connected to its muxed input. ACI1 and ACI0 are used to select among even and odd pins. The AC1Mux bit field controls the bits for those muxes and is located in the Analog Output Buffer Control register (ABF_CR0). There are up to two additional analog inputs that go directly into the Switch Capacitor PSoC blocks.

For additional information, refer to the [AMX_IN register on page 175](#).

20.2.2 ABF_CR0 Register

Addr.	Name	Cols.	Bit 7	Bit 6	Bit 5	Bit 4	Bit 3	Bit 2	Bit 1	Bit 0	Access
1,62h	ABF_CR0	4	ACol1Mux	ACol2Mux	ABUF1EN	ABUF2EN	ABUF0EN	ABUF3EN	Bypass	PWR	RW : 00
		2	ACol1Mux		ABUF1EN		ABUF0EN		Bypass	PWR	
		1	ACol1Mux		ABUF1EN				Bypass	PWR	

The Analog Output Buffer Control Register 0 (ABF_CR0) controls analog input muxes from Port 0 and the output buffer amplifiers that drive column outputs to device pins.

Depending on the number of analog columns your PSoC device has, bits 6, 4, 3, and 2 may be reserved. Refer to the table titled “PSoC Device Characteristics” on page 22.

Bit 7: ACol1MUX. A mux selects the output of column 0 input mux or column 1 input mux. When set, this bit sets the column 1 input to column 0 input mux output.

Bit 6: ACol2MUX. A multiplexer selects the output of column 2 input mux or column 3 input mux. When set, this bit sets the column 2 input to column 3 input mux output.

Bits 5 to 2: ABUFxEN. These bits enable or disable the column output amplifiers.

Bit 1: Bypass. Bypass mode connects the analog output driver input directly to the output. When this bit is set, all analog output drivers will be in bypass mode. This is a high impedance connection used primarily for measurement and calibration of internal references. Use of this feature is not recommended for customer designs.

Bit 0: PWR. This bit is used to set the power level of the analog output drivers. When this bit is set, all of the analog output drivers will be in a High Power mode.

For additional information, refer to the [ABF_CR0 register on page 267](#).

21. Analog Reference



This chapter discusses the Analog Reference generator and its associated register. The reference generator establishes a set of three internally fixed reference voltages for AGND, RefHi, and RefLo. For PSoC devices with one analog column, a fixed analog ground (AGND) of $V_{dd}/2$ is supplied. For information on the analog reference for the CY8C21x34, CY8C21x23, CY7C603xx, and CYWUSB6953 PSoC devices, refer to the [Two Column Limited Analog System chapter on page 431](#). For a quick reference of all PSoC registers in address order, refer to the [Register Details chapter on page 147](#).

21.1 Architectural Description

The PSoC device is a single supply part, with no negative voltage available or applicable. Depending on the number of analog columns in your PSoC device (refer to the table titled “PSoC Device Characteristics” on page 371), [Figure 21-1](#) shows the analog reference control schematic.

Analog ground (AGND) is constructed near mid-supply. This ground is routed to all analog blocks and separately buffered within each block. Note that there may be a small offset voltage between buffered analog grounds. RefHi and RefLo signals are generated, buffered, and routed to the analog blocks. RefHi and RefLo are used to set the conversion range (that is, span) of **analog-to-digital (ADC)** and **digital-to-analog (DAC)** converters. RefHi and RefLo can also be used to set thresholds in comparators for four and two column PSoC devices.

The reference array supplies voltage to all blocks and current to the Switched Capacitor blocks. At higher block clock rates, there is increased reference current demand; the reference power should be set equal to the highest power level of the analog blocks used.

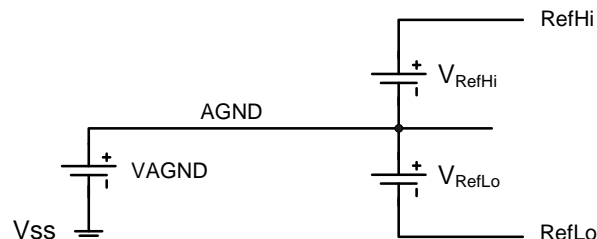

Figure 21-1. Analog Reference Structure

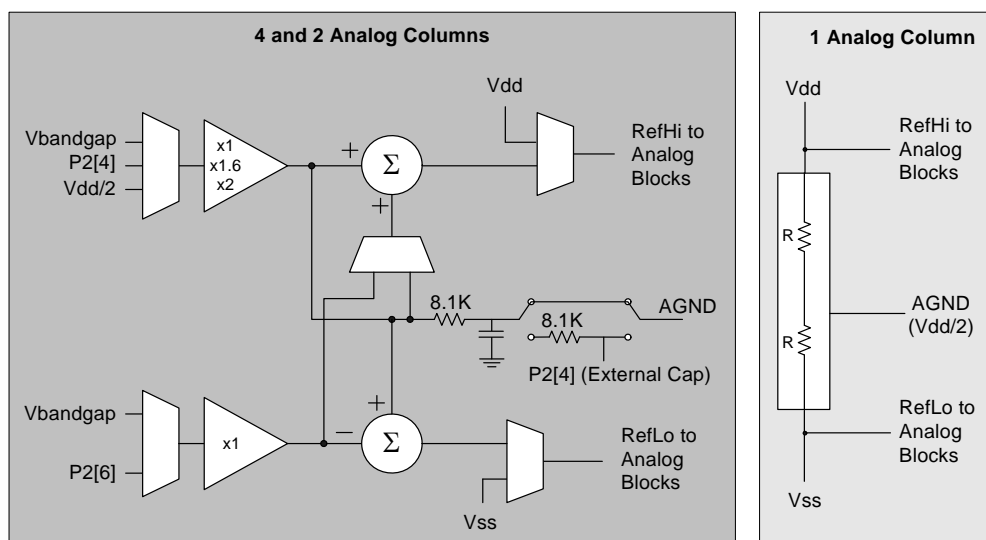

Figure 21-2. Analog Reference Control Schematic

21.2 Register Definitions

The following register is associated with the Analog Reference. Note that this register does not apply to the CY8C21x34, CY8C21x23, CY7C603xx, and CYWUSB6953 PSoC devices. For a complete table of all analog registers, refer to the “Summary Table of the Analog Registers” on page 373.

The register description below has an associated register table showing the bit structure. Depending on how many analog columns your PSoC device has (see the Cols. column in the register tables below), only certain bits are accessible to be read or written. The bits that are grayed out throughout this manual are reserved bits and are not detailed in the register description that follows. Reserved bits should always be written with a value of ‘0’.

21.2.1 ARF_CR Register

Addr.	Name	Cols.	Bit 7	Bit 6	Bit 5	Bit 4	Bit 3	Bit 2	Bit 1	Bit 0	Access
0,63h	ARF_CR	4, 2		HBE		REF[2:0]		PWR[2:0]			RW : 00

The Analog Reference Control Register (ARF_CR) is used to configure various features of the configurable analog references.

This register can only be used with four and two column PSoC devices.

Note The external bypass capacitor bit 6 (AGNDBYP) in the Bandgap Trim register (BDG_TR: 1, EAh) controls the external bypass capacitor. The default value is zero, which disables this function (see [Figure 21-2](#)). The figure shows the two switches in the AGND path in their default state. If bit 6 is set, then the P2[4] IO should be tri-stated and an external capacitor connect from P2[4] to Vss.

Bit 6: HBE. This bit controls the *bias* level for all the opamps. It operates with the power setting in each block, to set the parameters of that block. Most applications will benefit from the low bias level. At high bias, the analog block opamps have a faster slew rate, but slightly less voltage swing and higher power.

Bits 5 to 3: REF[2:0]. REF (AGND, RefHI, and RefLO) sets the analog array reference control, selecting specific combinations of voltage for analog ground and references. Many of these reference voltages are based on the precision internal reference, a silicon bandgap operating at 1.30 volts. This reference has good thermal stability and power supply rejection.

Alternatively, the power supply can be scaled to provide analog ground and references; this is particularly useful for signals which are ratiometric to the power supply voltage. See [Table 21-2](#).

User supplied external precision references can be connected to Port 2 inputs (available on 28 pin and larger parts). This is useful in setting reference for specific customer applications, such as a ± 1.00 V (from AGND) ADC scale. References derived from Port 2 inputs are limited to the same output voltage range as the opamps in the analog blocks.

Note that only the 010b setting for REF[2:0] is valid in the one column PSoC device. This sets AGND=Vdd/2, RefHi=Vdd, and RefLo=Vss.

Bits 2 to 0: PWR[2:0]. PWR controls the bias current and bandwidth for all of the opamps in the analog reference block. PWR also provides on/off control in various rows of the analog array.

Table 21-1. Analog Array Power Control Bits

PWR[2:0]	CT Row	Both SC Rows	REF Bias
000b	Off	Off	Off
001b	On	Off	Low
010b	On	Off	Medium
011b	On	Off	High
100b	Off	Off	Off
101b	On	On	Low
110b	On	On	Medium
111b	On	On	High

For additional information, refer to the [ARF_CR register](#) on page 179.

Table 21-2. REF[2:0]: AGND, RefHI, and RefLO Operating Parameters for 4 and 2* Column PSoC Devices

REF [2:0]	AGND		RefHI		RefLO		Notes
	Source	Voltage	Source	Voltage	Source	Voltage	
000b	Vdd/2	2.5 V 1.65 V	Vdd/2+Vbg	3.8 V 2.95 V	Vdd/2-Vbg	1.2 V 0.35 V	5.0 V System 3.3 V System
001b	P2[4]	2.2 V	P2[4]+P2[6]	3.2 V	P2[4]-P2[6]	1.2 V	User Adjustable. Example: P2[4]=2.2V and P2[6]=1.0V
010b	Vdd/2	2.5 V 1.65 V	Vdd	5.0 V 3.3 V	Vss	0.0 V 0.0 V	5.0 V System 3.3 V System
011b	2*Vbg	2.6 V	3*Vbg	3.9 V	1*Vbg	1.3 V	Not for 3.3 V Systems
100b	2*Vbg	2.6 V	2*Vbg+P2[6]	3.6 V	2*Vbg-P2[6]	1.6 V	P26 < Vdd - 2.6. Example: P2[6]=1.0V
101b	P2[4]	2.2 V	P2[4]+Vbg	3.5 V	P2[4]-Vbg	0.9 V	User Adjustable. Example: P2[4]=2.2V 1.3 < P2[4] < Vdd - 1.3
110b	Vbg	1.30 V	2*Vbg	2.6 V	Vss	0	5.0 V System 3.3 V System
111b	1.6*Vbg	2.08 V	3.2*Vbg	4.16 V	Vss	0	Not for 3.3 V Systems

* This table does not include the two column limited functionality of the CY8C21x34, CY8C21x23, CY7C603xx, and CYWUSB6953 PSoC devices. See the Two Column Limited Analog System chapter on page 431 for more information.

22. Continuous Time PSoC Block



This chapter discusses the Analog Continuous Time PSoC Block and its associated registers. This block supports programmable **gain** or **attenuation** opamp circuits; instrumentation amplifiers, using two CT blocks (differential gain); and modest response-time analog comparators. For information on the analog continuous time PSoC block for the CY8C21x34, CY8C21x23, CY7C603xx, and CYWUSB6953 PSoC devices, refer to the [Two Column Limited Analog System](#) chapter on page 431. For a complete table of the Continuous Time PSoC Block registers, refer to the “[Summary Table of the Analog Registers](#)” on page 373. For a quick reference of all PSoC registers in address order, refer to the [Register Details](#) chapter on page 147.

22.1 Architectural Description

The Analog Continuous Time blocks are built around a rail-to-rail input and output, low offset, low **noise** opamp. There are several analog multiplexers (muxes) controlled by register bit settings in the control registers that determine the signal topology inside the block. There is also a precision resistor string located in the feedback path of the opamp which is controlled by register bit settings.

The block also contains a low power comparator, connected to the same inputs and outputs as the main amplifier. This comparator is useful for providing a digital compare output in low power sleep modes, when the main amplifier is powered off.

There are three discrete outputs from this block. These outputs connect to the following buses:

1. The analog output bus (ABUS), which is an analog bus resource shared by all of the analog blocks in the analog column. This signal may also be routed externally through an output buffer.
2. The comparator bus (CBUS), which is a digital bus resource shared by all of the analog blocks in the analog column.
3. The local output buses (OUT, GOUT, and LOUT), which are routed to neighboring blocks. GOUT and LOUT refer to the gain/loss mode configuration of the block and connect to GIN/LIN inputs of neighboring blocks.

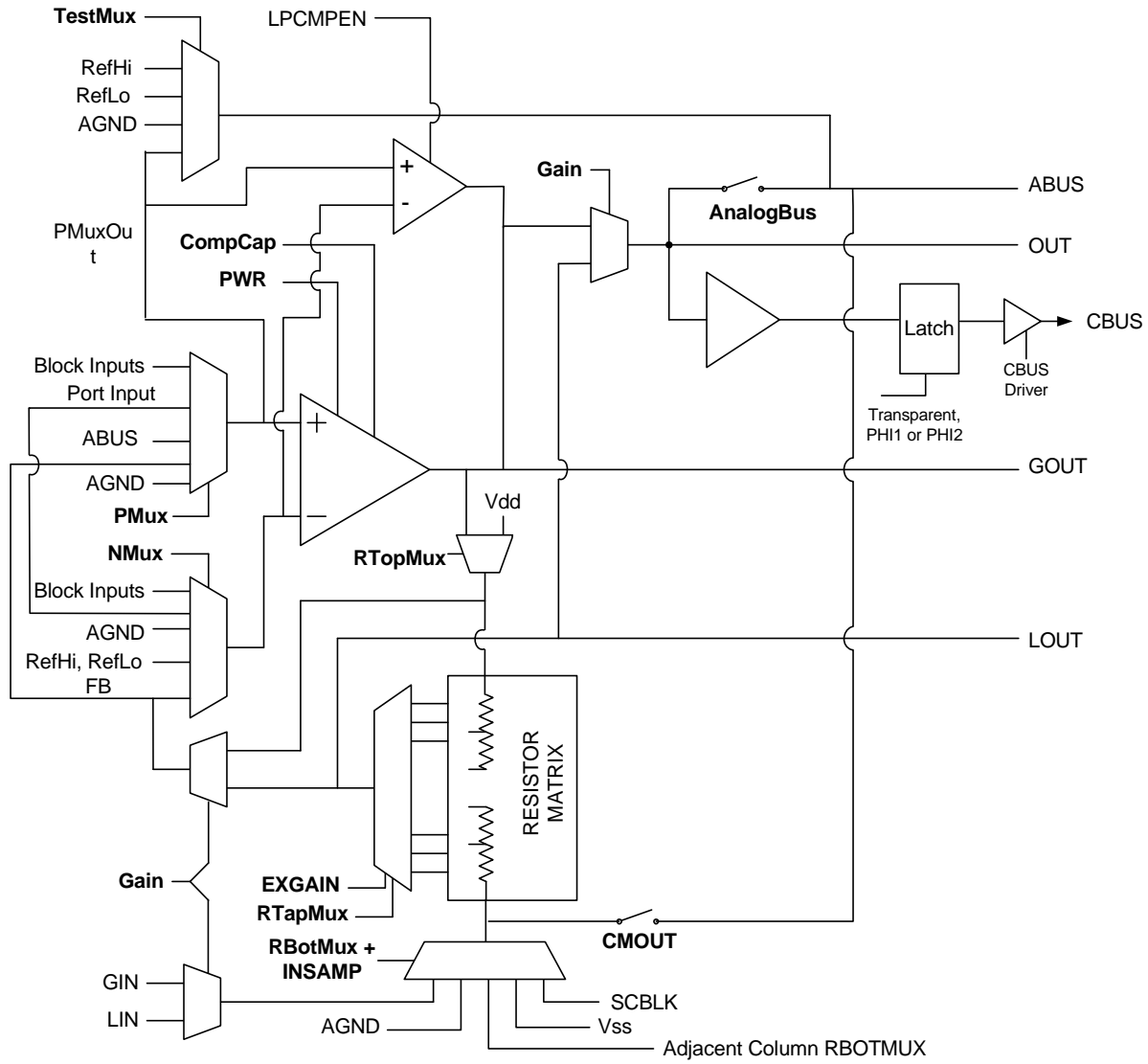

Figure 22-1. Analog Continuous Time Block Diagram

22.2 Register Definitions

The following registers are associated with the Continuous Time (CT) PSoC Block and are listed in address order. Each register description has an associated register table showing the bit structure for that register. Note that the CT PSoC Block register definitions for the CY8C21x34, CY8C21x23, CY7C603xx, and CYWUSB6953 PSoC devices are listed in the [Two Column Limited Analog System](#) chapter on page 431. For a complete table of the CT PSoC Block registers, refer to the “[Summary Table of the Analog Registers](#)” on page 373.

Depending on how many analog columns your PSoC device has (see the Cols. column in the register tables below), only certain bits are accessible to be read or written. The bits that are grayed out throughout this manual are reserved bits and are not detailed in the register descriptions that follow. Reserved bits should always be written with a value of ‘0’.

In the tables below, an “x” before the comma in the address field (in the “Add.” column) indicates that the register exists in both register banks. The register naming convention for arrays of PSoC blocks and their registers is <Prefix>mn<Suffix>, where m=row index and n=column index. Therefore, ACB01CR2 is a register for an analog PSoC block in row 0 column 1.

22.2.1 ACBxxCR3 Register

Add.	Name	Cols.	Bit 7	Bit 6	Bit 5	Bit 4	Bit 3	Bit 2	Bit 1	Bit 0	Access
x,70h	ACB00CR3	4, 2					LPCMPEN	CMOUT	INSAMP	EXGAIN	RW : 00
x,74h	ACB01CR3	4, 2, 1					LPCMPEN	CMOUT	INSAMP	EXGAIN	RW : 00
x,78h	ACB02CR3	4					LPCMPEN	CMOUT	INSAMP	EXGAIN	RW : 00
x,7Ch	ACB03CR3	4					LPCMPEN	CMOUT	INSAMP	EXGAIN	RW : 00

LEGEND

x An “x” before the comma in the address field indicates that the register exists in both register banks.

The Analog Continuous Time Type B Block Control Register 3 (ACBxxCR3) is one of four registers used to configure a type B continuous time PSoC block.

The analog array can be used to build two different forms of instrumentation amplifiers. Two continuous time blocks combine to make the two-opamp instrumentation amplifier illustrated in [Figure 22-2](#).

Two continuous time blocks and one switched capacitor block combine to make a three-opamp instrumentation amplifier (see [Figure 22-3](#)).

The three-opamp instrumentation amplifier handles a larger common mode input range but takes more resources. Bit 2 (CMOUT) and bit 1 (INSAMP) control switches are involved in the three-opamp instrumentation amplifier.

Depending on the address of the registers in the above table (in the “Add.” column), these registers are used for four, two, and one column PSoC devices (in the “Cols.” column). The following are descriptions of the ACBxxCR3 register bits that are not reserved.

Bit 3: LPCMPEN. Each continuous time block has a low power comparator connected in *parallel* with the block’s main opamp/comparator. The low power comparator is used in applications where low power is more important than low noise and low offset. The low power comparator operates when the LPCMPEN bit is set high. Since the main opamp/comparator’s output is connected to the low power comparator’s output, only one of the comparators should be active at a particular time. The main opamp/comparator is powered

down by setting ACBxxCR2: PWR[1:0] to 00b, or setting ARF_CR: PWR[2:0] to x00b. The low power comparator is unaffected by the PWR bits in the ACBxxCR2 and ARF_CR registers.

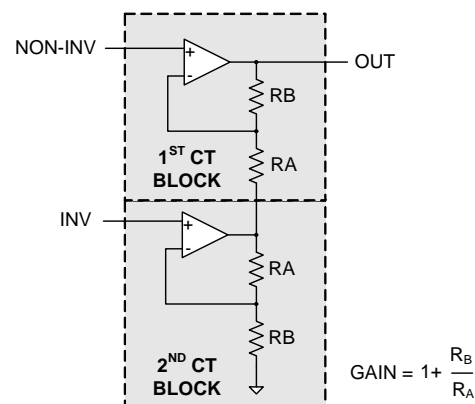

Figure 22-2. Two-Opamp Instrumentation Amplifier

Bit 2: CMOUT. If this bit is high, then the node formed by the connection of the resistors, between the continuous time blocks, is connected to that continuous time block’s ABUS. This node is the common mode of the inputs to the instrumentation amplifier. The CMOUT bit is optional for the three-opamp instrumentation amplifier.

Bit 1: INSAMP. This bit is used to connect the resistors of two continuous time blocks as part of a three-opamp instrumentation amplifier. The INSAMP bit must be high for the three-opamp instrumentation amplifier (see Figure 22-3).

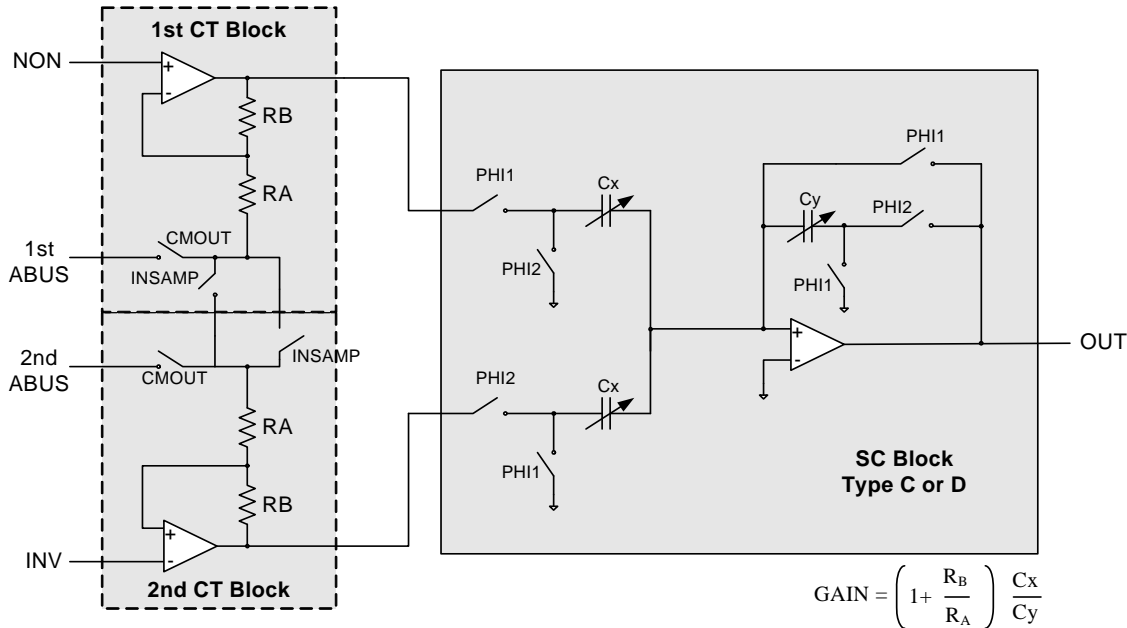

Figure 22-3. Three-Opamp Instrumentation Amplifier

Bit 0: EXGAIN. The continuous time block's resistor tap is specified by the value of ACBxxCR3 EXGAIN, combined with the value of ACBxxCR0 RtapMux[3:0]. For RtapMux values from 02h through 15h, the EXGAIN bit has no effect on which tap is selected. (See the ACBxxCR0 register for details.) The EXGAIN bit enables additional resistor tap selections for RtapMux = 01h and RtapMux = 00h (see Figure 22-4).

For additional information, refer to the ACBxxCR3 register on page 187.

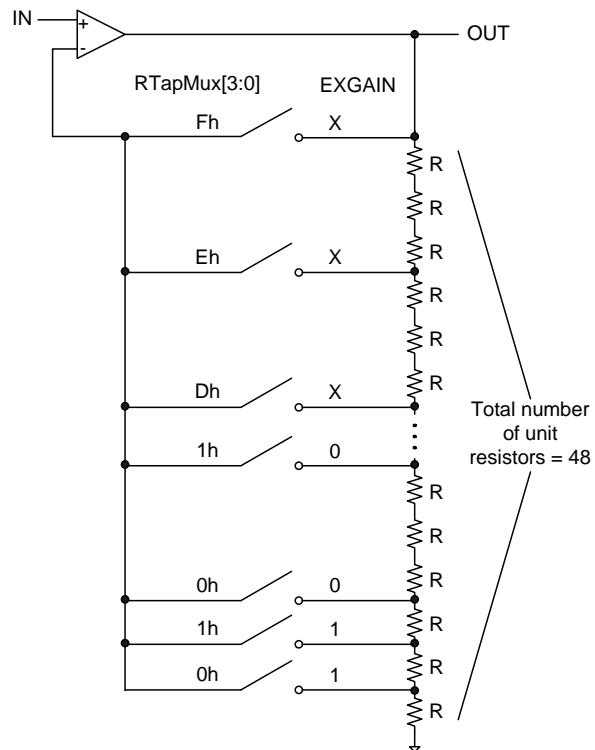

Figure 22-4. CT Block in Gain Configuration

22.2.2 ACBxxCR0 Register

Add.	Name	Cols.	Bit 7	Bit 6	Bit 5	Bit 4	Bit 3	Bit 2	Bit 1	Bit 0	Access
x,71h	ACB00CR0	4, 2	RTapMux[3:0]				Gain	RTopMux	RBotMux[1:0]		RW : 00
x,75h	ACB01CR0	4, 2, 1	RTapMux[3:0]				Gain	RTopMux	RBotMux[1:0]		RW : 00
x,79h	ACB02CR0	4	RTapMux[3:0]				Gain	RTopMux	RBotMux[1:0]		RW : 00
x,7Dh	ACB03CR0	4	RTapMux[3:0]				Gain	RTopMux	RBotMux[1:0]		RW : 00

LEGEND

x An "x" before the comma in the address field indicates that the register exists in both register banks.

The Analog Continuous Time Type B Block Control Register 0 (ACBxxCR0) is one of four registers used to configure a type B continuous time PSoC block.

Depending on the address of the registers in the above table (in the "Add." column), these registers are used for four, two, and one column PSoC devices (in the "Cols." column).

Bits 7 to 4: RTapMux[3:0]. These bits, in combination with the EXGAIN bit 0 in the ACBxxCR3 register, select the tap of the resistor string.

Bit 3: Gain. This bit controls whether the resistor string is connected around the opamp as for gain (tap to inverting opamp input) or for loss (tap to output of the block). Note

that setting Gain alone does not guarantee a gain or loss block. Routing of the ends of the resistor string determine this.

Bit 2: RTopMux. This bit controls the top end of the resistor string, which can either be connected to Vdd or to the opamp output.

Bits 1 and 0: RBotMux[1:0]. These bits, in combination with the INSAMP bit 1 in the ACBxxCR3 register, control the connection of the bottom end of the resistor string.

For additional information, refer to the [ACBxxCR0 register on page 188](#).

22.2.3 ACBxxCR1 Register

Add.	Name	Cols.	Bit 7	Bit 6	Bit 5	Bit 4	Bit 3	Bit 2	Bit 1	Bit 0	Access
x,72h	ACB00CR1	4, 2	AnalogBus	CompBus	NMux[2:0]		PMux[2:0]				RW : 00
x,76h	ACB01CR1	4, 2, 1	AnalogBus	CompBus	NMux[2:0]		PMux[2:0]				RW : 00
x,7Ah	ACB02CR1	4	AnalogBus	CompBus	NMux[2:0]		PMux[2:0]				RW : 00
x,7Eh	ACB03CR1	4	AnalogBus	CompBus	NMux[2:0]		PMux[2:0]				RW : 00

LEGEND

x An "x" before the comma in the address field indicates that the register exists in both register banks.

The Analog Continuous Time Type B Block Control Register 1 (ACBxxCR1) is one of four registers used to configure a type B continuous time PSoC block.

Depending on the address of the registers in the above table (in the "Add." column), these registers are used for four, two, and one column PSoC devices (in the "Cols." column).

Bit 7: AnalogBus. This bit controls the analog output bus (ABUS). A CMOS switch connects the opamp output to the analog bus.

Bit 6: CompBus. This bit controls a tri-state buffer that drives the comparator logic. If no block in the analog column

is driving the comparator bus, it will be driven low externally to the blocks.

Bits 5 to 3: NMux[2:0]. These bits control the multiplexing of inputs to the inverting input of the opamp. There are seven input choices from outside the block, plus the internal feedback selection from the resistor string top.

Bits 2 to 0: PMux[2:0]. These bits control the multiplexing of inputs to the non-inverting input of the opamp. There are seven input choices from outside the block, plus the internal feedback selection from the resistor string top.

For additional information, refer to the [ACBxxCR1 register on page 190](#).

22.2.4 ACBxxCR2 Register

Addr.	Name	Cols.	Bit 7	Bit 6	Bit 5	Bit 4	Bit 3	Bit 2	Bit 1	Bit 0	Access
x,73h	ACB00CR2	4, 2	CPhase	CLatch	CompCap	TMUXEN	TestMux[1:0]		PWR[1:0]		RW : 00
x,77h	ACB01CR2	4, 2, 1	CPhase	CLatch	CompCap	TMUXEN	TestMux[1:0]		PWR[1:0]		RW : 00
x,7Bh	ACB02CR2	4	CPhase	CLatch	CompCap	TMUXEN	TestMux[1:0]		PWR[1:0]		RW : 00
x,7Fh	ACB03CR2	4	CPhase	CLatch	CompCap	TMUXEN	TestMux[1:0]		PWR[1:0]		RW : 00

LEGEND

x An “x” before the comma in the address field indicates that the register exists in both register banks.

The Analog Continuous Time Type B Block Control Register 2 (ACBxxCR2) is one of four registers used to configure a type B continuous time PSoC block.

Depending on the address of the registers in the above table (in the “Addr.” column), these registers are used for four, two, and one column PSoC devices (in the “Cols.” column).

Bit 7: CPhase. This bit controls which internal clock phase the comparator data is latched on.

Bit 6: CLatch. This bit controls whether the latch is active or if it is always transparent.

Bit 5: CompCap. This bit controls whether or not the compensation capacitor is enabled in the opamp. By not switching in the compensation capacitance, a much faster response is obtained if the amplifier is used as a comparator.

Bit 4: TMUXEN. If the TMUXEN bit is high, then the value of TestMux[1:0] determines which test mux input is connected to the ABUS for that particular continuous time block. If the TMUXEN bit is low, then none of the test mux inputs are connected to the ABUS regardless of the value of TestMux[1:0].

Bits 3 and 2: TextMux[1:0]. These bits select which signal is connected to the analog bus.

Bits 1 and 0: PWR[1:0]. Power is encoded to select one of three power levels or power down (off). The blocks power up in the off state. Combined with the Turbo mode, this provides six power levels. Turbo mode is controlled by the HBE bit of the Analog Reference Control register ([ARF_CR](#)).

For additional information, refer to the [ACBxxCR2 register on page 193](#).

23. Switched Capacitor PSoC Block



This chapter presents the Analog Switched Capacitor Block and its associated registers. The analog Switched Capacitor (SC) blocks are built around a low offset, low noise operational amplifier. For information on the analog switched capacitor PSoC block for the CY8C21x34, CY8C21x23, CY7C603xx, and CYWUSB6953 PSoC devices, refer to the [Two Column Limited Analog System](#) chapter on page 431. For a complete table of the Switched Capacitor PSoC Block registers, refer to the “[Summary Table of the Analog Registers](#)” on page 373. For a quick reference of all PSoC registers in address order, refer to the [Register Details](#) chapter on page 147.

23.1 Architectural Description

The Analog Switched Capacitor blocks are built around a rail-to-rail, input and output, low offset and low noise opamp. (Refer to [Figure 23-1](#) and [Figure 23-2](#).) There are several analog multiplexers (muxes) controlled by register bit settings in the control registers that determine the signal topology inside the block. There are four user-selectable capacitor arrays inside this block connected to the opamp.

There are four analog arrays. Three of the four arrays are input arrays and are labeled A Cap Array, B Cap Array, and C Cap Array. The fourth array is the feedback path array and is labeled F Cap Array. All arrays have user-selectable unit values: one array is in the feedback path of the opamp and three arrays are in the input path of the opamp. Analog muxes, controlled by bit settings in control registers, set the capacitor topology inside the block. A group of muxes are used for the signal processing and switch synchronously to clocks PHI1 and PHI2, with behavior that is modified by control register settings. There is also an analog comparator that converts the opamp output (relative to the local analog ground) into a digital signal.

There are two types of Analog Switched Capacitor blocks called Type C and Type D. Their primary differences relate to connections of the C Cap Array and the block’s position in a two-pole filter section. The Type D block also has greater flexibility in switching the B Cap Array.

There are three discrete outputs from this block. These outputs connect to the following buses:

1. The analog output bus (ABUS), which is an analog bus resource shared by all of the analog blocks in the analog column. This signal may also be routed externally through the output buffer. The ABUS of each column has a 1.4 pF capacitor to GND. This capacitor may be used to hold a sampled value on the ABUS net. Although there is only one capacitor per column, it is shown in both [Figure 23-1](#) and [Figure 23-2](#) to allow visualization of the sample and hold function. See the description of the ClockPhase bit in the ASCxxCR0 and ASDxxCR0 registers in section [23.3 Register Definitions](#).
2. The comparator bus (CBUS), which is a digital bus resource shared by all of the analog blocks in the analog column.
3. The local output bus (OUT), which is an analog node, is routed to neighboring block inputs.

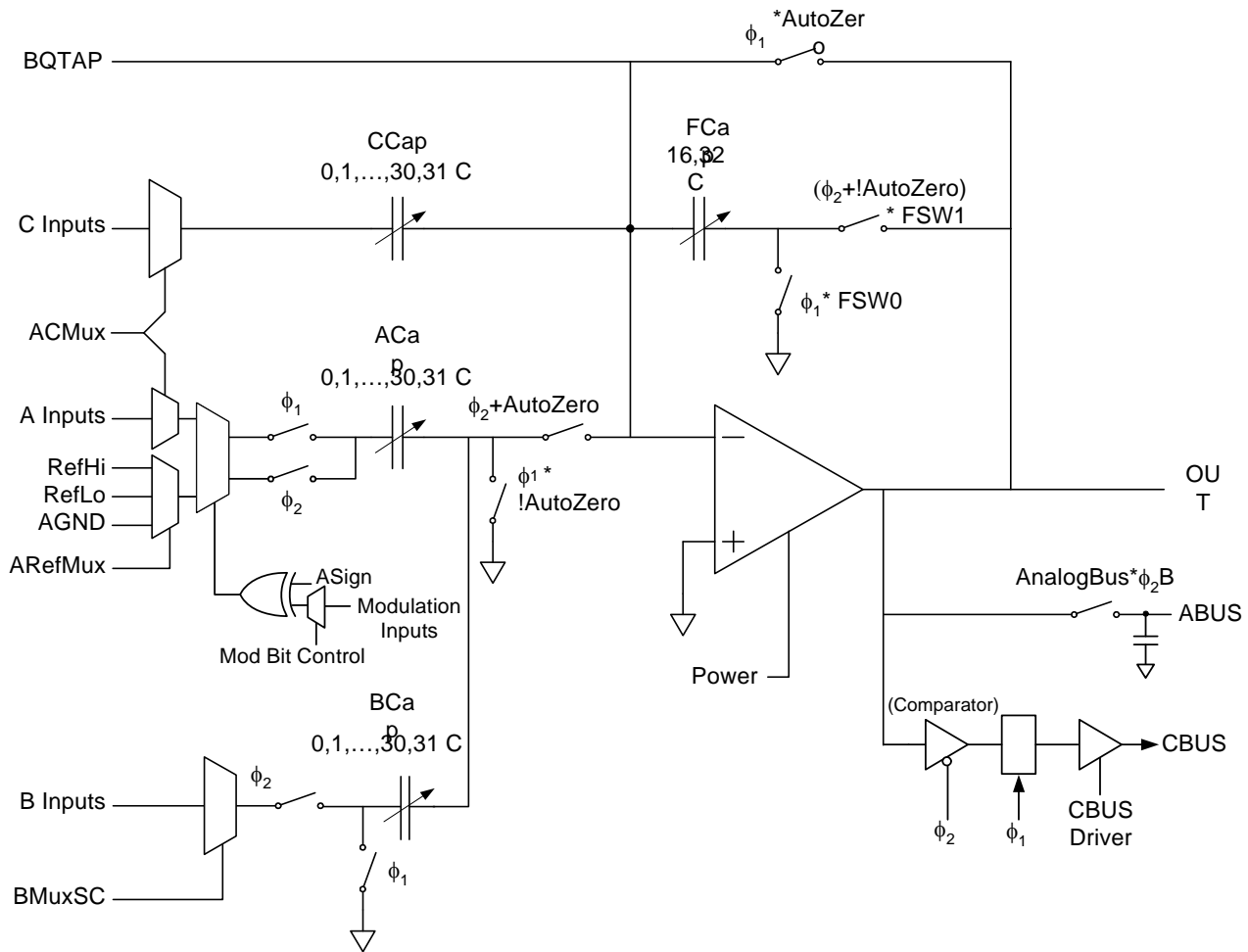

Figure 23-1. Analog Switch Cap Type C PSoC Blocks

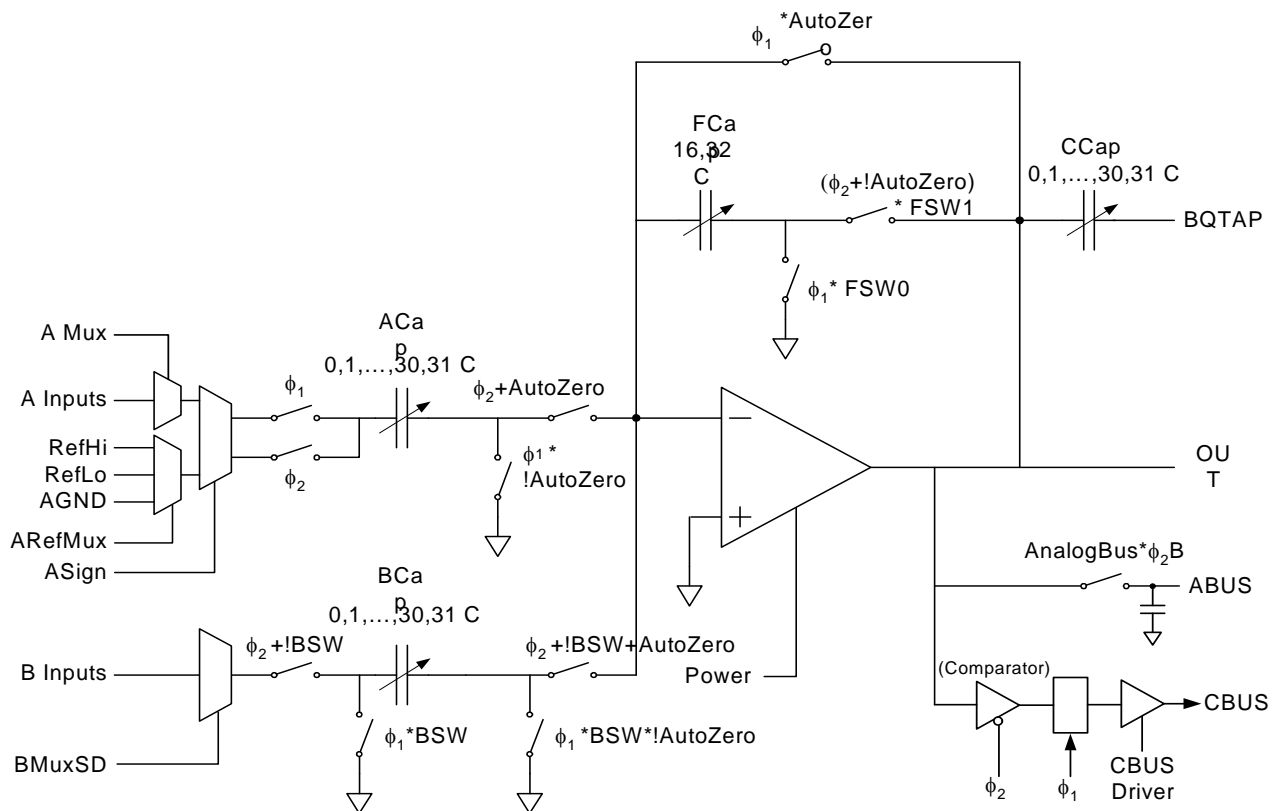

Figure 23-2. Analog Switch Cap Type D PSoC Blocks

23.2 Application Description

The analog Switched Capacitor (SC) blocks support Delta-Sigma, Successive Approximation, and Incremental Analog-to-Digital Conversion, Capacitor DACs, and SC filters. They have three input arrays of binary-weighted switched capacitors, allowing user programmability of the capacitor weights. This provides summing capability of two (CDAC) scaled inputs and a non-switched capacitor input.

The non-switched capacitor node is labeled “BQTAP” in the figure above. For two and four column PSoC devices, the local connection of BQTAP is between horizontal neighboring SC blocks within an analog bi-column. For one column PSoC devices, the local connection of BQTAP is vertical between the SC blocks. Since the input of SC Block C (ASCxx) has this additional switched capacitor, it is configured for the input stage of such a switched capacitor bi-quad **filter**. When followed by an SC Block D (ASDxx) integrator, this combination of blocks can be used to provide a full universal two-pole switched capacitor bi-quad filter.

23.3 Register Definitions

The following registers are associated with the Switched Capacitor (SC) PSoC Block and are listed in address order. Note that the SC PSoC Block register definitions for the CY8C21x34, CY8C21x23, CY7C603xx, and CYWUSB6953 PSoC devices are listed in the [Two Column Limited Analog System chapter on page 431](#). Each register description has an associated register table showing the bit structure for that register. For a complete table of SC PSoC Block registers, refer to the [“Summary Table of the Analog Registers” on page 373](#).

Depending on how many analog columns your PSoC device has (see the Cols. column in the register tables below), only certain bits are accessible to be read or written. The bits that are grayed out throughout this manual are reserved bits and are not detailed in the register descriptions that follow. Reserved bits should always be written with a value of '0'.

Figure 23-3 applies to the ACap, BCap, and CCap functionality for the capacitor registers. The XCap field is used to store the binary encoded value for capacitor X, where X can be A (ACap), B (BCap), or C (CCap), in both the ASCxxCRx and ASDxx-CRx registers. Figure 23-3 illustrates the switch settings for the example ACap[4:0]=14h=10100b=20d.

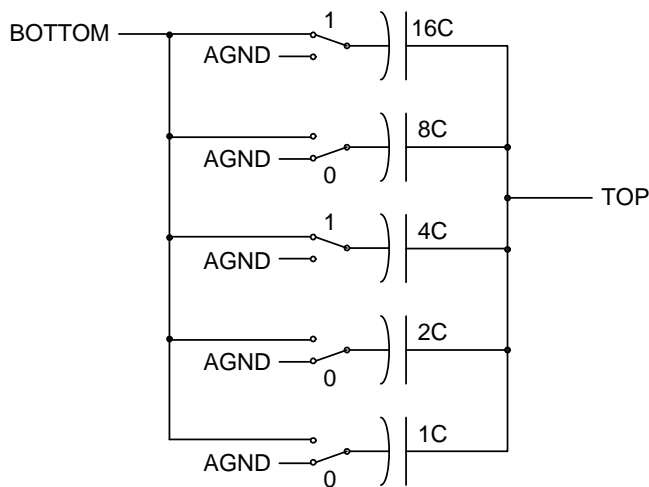

Figure 23-3. Example Switch Capacitor Settings

Analog Switch Cap Type C PSoC Block Control Registers

In the tables below, an “x” before the comma in the address field (in the “Add.” column) indicates that the register exists in both register banks. The register naming convention for arrays of PSoC blocks and their registers is <Prefix>mn<Suffix>, where m=row index and n=column index. Therefore, ASC21CR2 is a register for an analog PSoC block in row 2 column 1.

23.3.1 ASCxxCR0 Register

Add.	Name	Cols.	Bit 7	Bit 6	Bit 5	Bit 4	Bit 3	Bit 2	Bit 1	Bit 0	Access
x,80h	ASC10CR0	4, 2	FCap	ClockPhase	ASign			ACap[4:0]			RW : 00
x,88h	ASC12CR0	4	FCap	ClockPhase	ASign			ACap[4:0]			RW : 00
x,94h	ASC21CR0	4, 2, 1	FCap	ClockPhase	ASign			ACap[4:0]			RW : 00
x,9Ch	ASC23CR0	4	FCap	ClockPhase	ASign			ACap[4:0]			RW : 00

LEGEND

x An “x” before the comma in the address field indicates that the register exists in both register banks.

The Analog Switch Cap Type C Block Control Register 0 (ASCxxCR0) is one of four registers used to configure a type C switch capacitor PSoC block.

Depending on the address of the registers in the above table (in the “Add.” column), these registers are used for four, two, and one column PSoC devices (in the “Cols.” column).

Bit 7: FCap. This bit controls the size of the switched feedback capacitor in the integrator.

Bit 6: ClockPhase. This bit controls the internal clock phasing relative to the input clock phasing. ClockPhase affects the output of the analog column bus, which is controlled by the AnalogBus bit in the Control 2 register.

This bit is the ClockPhase select that inverts the clock internal to the blocks. During normal operation of an SC block, for the amplifier of a column enabled to drive the output bus, the connection is only made for the last half of PHI2. (During PHI1 and for the first half of PHI2, the output bus floats at the last voltage to which it was driven.) This forms a sample and hold operation, using the output bus and its associated capacitance. This design prevents the output bus from being perturbed by the intermediate states of the SC operation (often a reset state for PHI1 and settling to the valid state during PHI2). The following are the exceptions:

1. If the ClockPhase bit in CR0 (for the SC block in question) is set to ‘1’, then the output is enabled for the whole of PHI2.

2. If the SHDIS signal is set in bit 6 of the Analog Clock Source Control register, then sample and hold operation is disabled for all columns and all enabled outputs of SC blocks are connected to their respective output buses for the entire period of their respective PHI2s.

This bit also affects the latching of the comparator output (CBUS). Both clock phases, PHI1 and PHI2, are involved in the output latching mechanism. The capture of the next value to be output from the latch (capture point event) happens during the falling edge of one clock phase. The rising edge of the other clock phase will cause the value to come out (output point event). This bit determines which clock phase triggers the capture point event, and the other clock will trigger the output point event. The value output to the comparator bus will remain stable between output point events.

Bit 5: ASign. This bit controls the switch phasing of the switches on the bottom plate of the ACap capacitor. The bottom plate samples the input or the reference.

Bits 4 to 0: ACap[4:0]. The ACap bits set the value of the capacitor in the A path.

For additional information, refer to the [ASCxxCR0 register on page 195](#).

23.3.2 ASCxxCR1 Register

Addr.	Name	Cols.	Bit 7	Bit 6	Bit 5	Bit 4	Bit 3	Bit 2	Bit 1	Bit 0	Access
x,81h	ASC10CR1	4, 2	ACMux[2:0]			BCap[4:0]				RW : 00	
x,89h	ASC12CR1	4	ACMux[2:0]			BCap[4:0]				RW : 00	
x,95h	ASC21CR1	4, 2, 1	ACMux[2:0]			BCap[4:0]				RW : 00	
x,9Dh	ASC23CR1	4	ACMux[2:0]			BCap[4:0]				RW : 00	

LEGEND

x An "x" before the comma in the address field indicates that the register exists in both register banks.

The Analog Switch Cap Type C Block Control Register 1 (ASCxxCR1) is one of four registers used to configure a type C switch capacitor PSoC block.

Depending on the address of the registers in the above table (in the "Addr." column), these registers are used for four, two, and one column PSoC devices (in the "Cols." column).

Bits 7 to 5: ACMUX[2:0]. These bits control the input muxing for both the A and C capacitor branches. The high order bit, ACMux[2], selects one of two inputs for the C branch.

Bits 4 to 0: BCap[4:0]. The BCap bits set the value of the capacitor in the B path.

For additional information, refer to the [ASCxxCR1 register on page 197](#).

23.3.3 ASCxxCR2 Register

Addr.	Name	Cols.	Bit 7	Bit 6	Bit 5	Bit 4	Bit 3	Bit 2	Bit 1	Bit 0	Access
x,82h	ASC10CR2	4, 2	AnalogBus	CompBus	AutoZero	CCap[4:0]				RW : 00	
x,8Ah	ASC12CR2	4	AnalogBus	CompBus	AutoZero	CCap[4:0]				RW : 00	
x,96h	ASC21CR2	4, 2, 1	AnalogBus	CompBus	AutoZero	CCap[4:0]				RW : 00	
x,9Eh	ASC23CR2	4	AnalogBus	CompBus	AutoZero	CCap[4:0]				RW : 00	

LEGEND

x An "x" before the comma in the address field indicates that the register exists in both register banks.

The Analog Switch Cap Type C Block Control Register 2 (ASCxxCR2) is one of four registers used to configure a type C switch capacitor PSoC block.

Depending on the address of the registers in the above table (in the "Addr." column), these registers are used for four, two, and one column PSoC devices (in the "Cols." column).

Bit 7: AnalogBus. This bit gates the output to the analog column bus (ABUS). The output on the ABUS is affected by the state of the ClockPhase bit in the Control 0 register. If AnalogBus is set to '0', the output to the analog column bus is tri-stated. If AnalogBus is set to '1', the signal that is output to the analog column bus is selected by the ClockPhase bit. If the ClockPhase bit is '0', the block output is gated by sampling clock on the last part of PHI2. If the ClockPhase bit is '1', the block output continuously drives the ABUS.

Bit 6: CompBus. This bit controls the output to the column comparator bus (CBUS). Note that if the CBUS is not driven

by anything in the column, it is pulled low. The comparator output is evaluated on the rising edge of internal PHI1 and is latched so it is available during internal PHI2.

Bit 5: AutoZero. This bit controls the shorting of the output to the inverting input of the opamp. When shorted, the opamp is basically a follower. The output is the opamp offset. By using the feedback capacitor of the integrator, the block can memorize the offset and create an offset cancellation scheme. AutoZero also controls a pair of switches between the A and B branches and the summing node of the opamp. If AutoZero is enabled, then the pair of switches is active. AutoZero also affects the function of the FSW1 bit in the Control 3 register.

Bits 4 to 0: CCap[4:0]. The CCap bits set the value of the capacitor in the C path.

For additional information, refer to the [ASCxxCR2 register on page 198](#).

23.3.4 ASCxxCR3 Register

Add.	Name	Cols.	Bit 7	Bit 6	Bit 5	Bit 4	Bit 3	Bit 2	Bit 1	Bit 0	Access
x,83h	ASC10CR3	4, 2	ARefMux[1:0]		FSW1	FSW0	BMuxSC[1:0]		PWR[1:0]		RW : 00
x,8Bh	ASC12CR3	4	ARefMux[1:0]		FSW1	FSW0	BMuxSC[1:0]		PWR[1:0]		RW : 00
x,97h	ASC21CR3	4, 2, 1	ARefMux[1:0]		FSW1	FSW0	BMuxSC[1:0]		PWR[1:0]		RW : 00
x,9Fh	ASC23CR3	4	ARefMux[1:0]		FSW1	FSW0	BMuxSC[1:0]		PWR[1:0]		RW : 00

LEGEND

x An "x" before the comma in the address field indicates that the register exists in both register banks.

The Analog Switch Cap Type C Block Control Register 3 (ASCxxCR3) is one of four registers used to configure a type C switch capacitor PSoC block.

Depending on the address of the registers in the above table (in the "Add." column), these registers are used for four, two, and one column PSoC devices (in the "Cols." column).

Bits 7 and 6: ARefMux[1:0]. These bits select the reference input of the A capacitor branch.

Bit 5: FSW1. This bit is used to control a switch in the integrator capacitor path. It connects the output of the opamp to the integrating cap. The state of the feedback switch is affected by the state of the AutoZero bit in the Control 2 register. If the FSW1 bit is set to '0', the switch is always disabled. If the FSW1 bit is set to '1', the AutoZero bit

determines the state of the switch. If the AutoZero bit is '0', the switch is enabled at all times. If the AutoZero bit is '1', the switch is enabled only when the internal PHI2 is high.

Bit 4: FSW0. This bit is used to control a switch in the integrator capacitor path. It connects the output of the opamp to analog ground.

Bits 3 and 2: BMuxSC[1:0]. These bits control the muxing to the input of the B capacitor branch.

Bits 1 and 0: PWR[1:0]. The power bits serve as encoding for selecting one of four power levels. The block always powers up in the off state.

For additional information, refer to the [ASCxxCR3 register on page 199](#).

Analog Switch Cap Type D PSoC Block Control Registers

In the tables below, an “x” before the comma in the address field (in the “Add.” column) indicates that the register exists in both register banks. The register naming convention for arrays of PSoC blocks and their registers is <Prefix>mn<Suffix>, where m=row index and n=column index. Therefore, ASD01CR0 is a register for an analog PSoC block in row 0 column 1.

23.3.5 ASDxxCR0 Register

Add.	Name	Cols.	Bit 7	Bit 6	Bit 5	Bit 4	Bit 3	Bit 2	Bit 1	Bit 0	Access
x,84h	ASD11CR0	4, 2, 1	FCap	ClockPhase	ASign			ACap[4:0]			RW : 00
x,8Ch	ASD13CR0	4	FCap	ClockPhase	ASign			ACap[4:0]			RW : 00
x,90h	ASD20CR0	4, 2	FCap	ClockPhase	ASign			ACap[4:0]			RW : 00
x,98h	ASD22CR0	4	FCap	ClockPhase	ASign			ACap[4:0]			RW : 00

LEGEND

x An “x” before the comma in the address field indicates that the register exists in both register banks.

The Analog Switch Cap Type D Block Control Register 0 (ASDxxCR0) is one of four registers used to configure a type D switch capacitor PSoC block.

Depending on the address of the registers in the above table (in the “Add.” column), these registers are used for four, two, and one column PSoC devices (in the “Cols.” column).

Bit 7: FCap. This bit controls the size of the switched feedback capacitor in the integrator.

Bit 6: ClockPhase. This bit controls the internal clock phasing relative to the input clock phasing. ClockPhase affects the output of the analog column bus which is controlled by the AnalogBus bit in the Control 2 register.

This bit is the ClockPhase select that inverts the clock internal to the blocks. During normal operation, of an SC block for the amplifier of a column enabled to drive the output bus, the connection is only made for the last half of PHI2. (During PHI1 and for the first half of PHI2, the output bus floats at the last voltage to which it was driven.) This forms a sample and hold operation using the output bus and its associated capacitance. This design prevents the output bus from being perturbed by the intermediate states of the SC operation (often a reset state for PHI1 and settling to the valid state during PHI2). The following are the exceptions:

1. If the ClockPhase bit in CR0 (for the SC block in question) is set to ‘1’, then the output is enabled for the whole of PHI2.

2. If the SHDIS signal is set in bit 6 of the Analog Clock Select register, then sample and hold operation is disabled for all columns and all enabled outputs of SC blocks are connected to their respective output buses, for the entire period of their respective PHI2s.

This bit also affects the latching of the comparator output (CBUS). Both clock phases, PHI1 and PHI2, are involved in the output latching mechanism. The capture of the next value to be output from the latch (capture point event) happens during the falling edge of one clock phase. The rising edge of the other clock phase will cause the value to come out (output point event). This bit determines which clock phase triggers the capture point event, and the other clock will trigger the output point event. The value output to the comparator bus will remain stable between output point events.

Bit 5: ASign. This bit controls the switch phasing of the switches on the bottom plate of the A capacitor. The bottom plate samples the input or the reference.

Bits 4 to 0: ACap[4:0]. The ACap bits set the value of the capacitor in the A path.

For additional information, refer to the [ASDxxCR0 register on page 200](#).

23.3.6 ASDxxCR1 Register

Addr.	Name	Cols.	Bit 7	Bit 6	Bit 5	Bit 4	Bit 3	Bit 2	Bit 1	Bit 0	Access
x,85h	ASD11CR1	4, 2, 1	AMux[2:0]			BCap[4:0]				RW : 00	
x,8Dh	ASD13CR1	4	AMux[2:0]			BCap[4:0]				RW : 00	
x,91h	ASD20CR1	4, 2	AMux[2:0]			BCap[4:0]				RW : 00	
x,99h	ASD22CR1	4	AMux[2:0]			BCap[4:0]				RW : 00	

LEGEND

x An "x" before the comma in the address field indicates that the register exists in both register banks.

The Analog Switch Cap Type D Block Control Register 1 (ASDxxCR1) is one of four registers used to configure a type D switch capacitor PSoC block.

Depending on the address of the registers in the above table (in the "Addr." column), these registers are used for four, two, and one column PSoC devices (in the "Cols." column).

Bits 7 to 5: AMux[2:0]. These bits control the input muxing for the A capacitor branch.

Bits 4 to 0: BCap[4:0]. The BCap bits set the value of the capacitor in the B path.

For additional information, refer to the [ASDxxCR1 register on page 201](#).

23.3.7 ASDxxCR2 Register

Addr.	Name	Cols.	Bit 7	Bit 6	Bit 5	Bit 4	Bit 3	Bit 2	Bit 1	Bit 0	Access
x,86h	ASD11CR2	4, 2, 1	AnalogBus	CompBus	AutoZero	CCap[4:0]				RW : 00	
x,8Eh	ASD13CR2	4	AnalogBus	CompBus	AutoZero	CCap[4:0]				RW : 00	
x,92h	ASD20CR2	4, 2	AnalogBus	CompBus	AutoZero	CCap[4:0]				RW : 00	
x,9Ah	ASD22CR2	4	AnalogBus	CompBus	AutoZero	CCap[4:0]				RW : 00	

LEGEND

x An "x" before the comma in the address field indicates that the register exists in both register banks.

The Analog Switch Cap Type D Block Control Register 2 (ASDxxCR2) is one of four registers used to configure a type D switch capacitor PSoC block.

Depending on the address of the registers in the above table (in the "Addr." column), these registers are used for four, two, and one column PSoC devices (in the "Cols." column).

Bit 7: AnalogBus. This bit gates the output to the analog column bus (ABUS). The output on the ABUS is affected by the state of the ClockPhase bit in the Control 0 Register. If AnalogBus is set to '0', the output to the ABUS is tri-stated. If AnalogBus is set to '1', the ClockPhase bit selects the signal that is output to the analog-column bus. If the ClockPhase bit is '0', the block output is gated by sampling clock on the last part of PHI2. If the ClockPhase bit is '1', the block ClockPhase continuously drives the ABUS.

Bit 6: CompBus. This bit controls the output to the column comparator bus (CBUS). Note that if the CBUS is not driven

by anything in the column, it is pulled low. The comparator output is evaluated on the rising edge of internal PHI1 and is latched so it is available during internal PHI2.

Bit 5: AutoZero. This bit controls the shorting of the output to the inverting input of the opamp. When shorted, the opamp is basically a follower. The output is the opamp offset. By using the feedback capacitor of the integrator, the block can memorize the offset and create an offset cancellation scheme. AutoZero also controls a pair of switches between the A and B branches and the summing node of the opamp. If AutoZero is enabled, then the pair of switches is active. AutoZero also affects the function of the FSW1 bit in the Control 3 register.

Bits 4 to 0: CCap[4:0]. The CCap bits set the value of the capacitor in the C path.

For additional information, refer to the [ASDxxCR2 register on page 202](#).

23.3.8 ASDxxCR3 Register

Addr.	Name	Cols.	Bit 7	Bit 6	Bit 5	Bit 4	Bit 3	Bit 2	Bit 1	Bit 0	Access
x,87h	ASD11CR3	4, 2, 1	ARefMux[1:0]		FSW1	FSW0	BSW	BMuxSD	PWR[1:0]		RW : 00
x,8Fh	ASD13CR3	4	ARefMux[1:0]		FSW1	FSW0	BSW	BMuxSD	PWR[1:0]		RW : 00
x,93h	ASD20CR3	4, 2	ARefMux[1:0]		FSW1	FSW0	BSW	BMuxSD	PWR[1:0]		RW : 00
x,9Bh	ASD22CR3	4	ARefMux[1:0]		FSW1	FSW0	BSW	BMuxSD	PWR[1:0]		RW : 00

LEGEND

x An "x" before the comma in the address field indicates that the register exists in both register banks.

The Analog Switch Cap Type D Block Control Register 3 (ASDxxCR3) is one of four registers used to configure a type D switch capacitor PSoC block.

Depending on the address of the registers in the above table (in the "Addr." column), these registers are used for four, two, and one column PSoC devices (in the "Cols." column).

Bits 7 and 6: ARefMux[1:0]. These bits select the reference input of the A capacitor branch.

Bit 5: FSW1. This bit is used to control a switch in the integrator capacitor path. It connects the output of the opamp to the integrating cap. The state of the switch is affected by the state of the AutoZero bit in the Control 2 register. If the FSW1 bit is set to '0', the switch is always disabled. If the FSW1 bit is set to '1', the AutoZero bit determines the state of the switch. If the AutoZero bit is '0', the switch is enabled at all times. If the AutoZero bit is '1', the switch is enabled only when the internal PHI2 is high.

Bit 4: FSW0. This bit is used to control a switch in the integrator capacitor path. It connects the output of the opamp to analog ground.

Bit 3: BSW. This bit is used to control switching in the B branch. If disabled, the B capacitor branch is a continuous time branch like the C branch of the SC A Block. If enabled, then on internal PHI1, both ends of the cap are switched to analog ground. On internal PHI2, one end is switched to the B input and the other end is switched to the summing node.

Bit 2: BMuxSD. This bit controls muxing to the input of the B capacitor branch. The B branch can be switched or unswitched.

Bits 1 and 0: PWR[1:0]. The power bits serve as encoding for selecting one of four power levels. The block always powers up in the off state.

For additional information, refer to the [ASDxxCR3 register on page 203](#).

24. Two Column Limited Analog



This chapter explains the Two Column Limited Analog System PSoC devices, CY8C21x34, CY8C21x23, CY7C603xx, and CYWUSB6953, and their associated registers. It details the entire analog system for two column limited functionality, including the analog interface, analog array, analog input configuration, analog reference, CT and SC blocks. For a complete table of the Two Column Limited Analog System registers for the CY8C21x34, CY8C21x23, CY7C603xx, and CYWUSB6953 PSoC devices, refer to the “[Summary Table for 2 Column Limited Analog System Registers](#)” on page 443. For a quick reference of all PSoC registers in address order, refer to the [Register Details](#) chapter on page 147.

Unique to the CY8C21x34, CY7C603xx, and CYWUSB6953 PSoC devices is the use of an IO analog multiplexer system resource. The IO Analog Multiplexer is described in the [IO Analog Multiplexer](#) chapter on page 517. A summary of the IO Analog Multiplexer registers are located in the section called “[System Resources](#)” on page 453.

24.1 Architectural Description

24.1.1 Analog Interface

Figure 24-1 displays the top level diagram of the CY8C21x34, CY8C21x23, CY7C603xx, and CYWUSB6953 PSoC devices’ analog interface system.

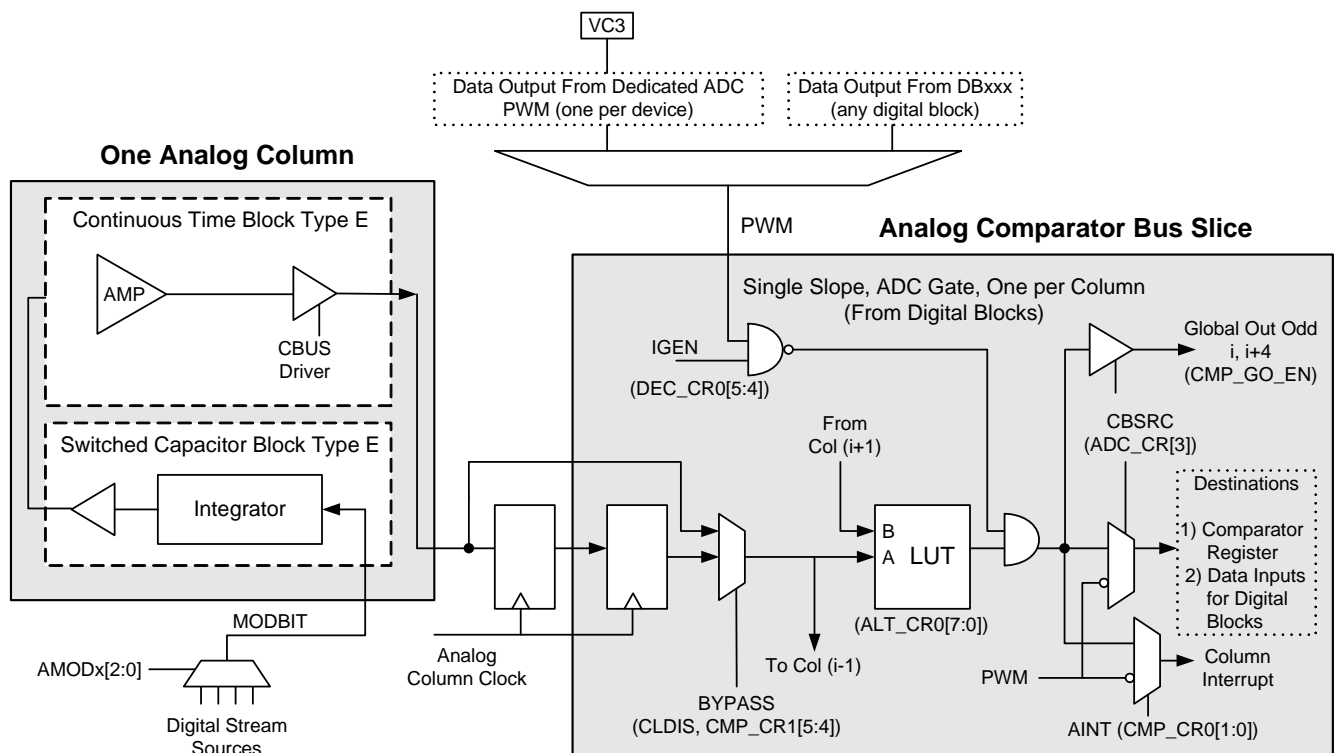

Figure 24-1. Analog Comparator Bus Slice of the CY8C21x34, CY8C21x23, CY7C603xx, and CYWUSB6953 PSoC Devices

24.1.1.1 Analog Comparator Bus Interface

Each analog column has a dedicated comparator bus associated with it. In the CY8C21x34, CY8C21x23, CY7C603xx, and CYWUSB6953 PSoC devices, only the Continuous Time (CT) block can drive this bus. The output on the comparator bus can drive into the digital blocks as a data input. It also serves as an input to Switched Capacitor (SC) blocks as an interrupt input, and is available as read only data in the Analog Comparator Control register (CMP_CR0). It can be driven to the global output bus by way of the Comparator to Global Output Enable register (CMP_GO_EN).

Figure 24-1 illustrates one column of the comparator bus. The comparator bus is synchronized by the selected column clock before it is available, to either drive the digital blocks, interrupt, SC blocks, or for it to be read in the CMP_CR0 register. There is also an option to bypass the synchronization in each column into a transparent mode by setting bits in the CMP_CR1 register.

As shown in Figure 24-1, the comparator bus output is gated by the primary output of a selected digital block. This feature is used to precisely control the conversion period of a single slope ADC. Any digital block can be used to drive the gate signal. This selection may be made with the ICLKS bits in registers DEC_CR0 and DEC_CR1. This function may be enabled on a column-by-column basis, by setting the IGEN bits in the DEC_CR0 register. Alternately, the dedicated ADC PWM, with VC3 as input, can be used to gate the ADC conversion period without the need for a digital block. When this dedicated PWM is configured, it overrides the ICLKS selection as defined by the DEC_CR0 and DEC_CR1 registers.

The analog comparator bus output values can be modified or combined with another analog comparator bus through the Analog Look-Up-Table (LUT) function. The LUT takes two inputs, A and B, and provides a selection of 16 possible logic functions for those inputs. The LUT A and B inputs for each column comparator output is shown in the following table.

Table 24-1. A and B Inputs for Each Column Comparator LUT Output for the CY8C21x34, CY8C21x23, CY7C603xx, and CYWUSB6953 Devices

Comparator LUT Output	A	B
Column 0	ACMP0	ACMP1
Column 1	ACMP1	0

The LUT configuration is set in two control registers, ALT_CR0 and ALT_CR1. Each selection for each column is encoded in four bits. The function value corresponding to the bit encoding is shown in the following table.

Table 24-2. RD1xLTx Register

LUTx[3:0]	0h: 0000: FALSE
	1h: 0001: A .AND. B
	2h: 0010: A .AND. B
	3h: 0011: A
	4h: 0100: A .AND. B
	5h: 0101: B
	6h: 0110: A .XOR. B
	7h: 0111: A .OR. B
	8h: 1000: A .NOR. B
	9h: 1001: A .XNOR. B
	Ah: 1010: B
	Bh: 1011: A .OR. B
	Ch: 1100: A
	Dh: 1101: A .OR. B
	Eh: 1110: A .NAND. B
	Fh: 1111: TRUE

24.1.1.2 Analog Column Clock Generation

The input clock source for each column clock generator is selectable according to the CLK_CR0 register. There are four selections for each column: VC1, VC2, ACLK0, and ACLK1. An additional selection, SYSCLK, is controlled by the CLK_CR3 register. The VC1 and VC2 clock signals are global system clocks. Programming options for these system clocks can be accessed in the OSC_CR1 register. Each of the ACLK0 and ACLK1 clock selections are driven by a selection of digital block outputs. The settings for the digital block selection are located in the CLK_CR1 and CLK_CR2 registers. The CLK_CR3 register has additional column clock options. This register allows for a direct SYSCLK option as well as the option to divide the selected column clock by 2, 4, or 8.

24.1.1.3 Single Slope ADC

A simplified block diagram of the single slope ADC (SSADC) implementation is shown in Figure 24-2. The core of the conversion algorithm involves a current source, an integrating capacitor, and a comparator. When the current source is activated, a linear voltage ramp is generated on the capacitor. This voltage is an input to an analog comparator circuit; the other input of which is the analog input voltage to be converted. With the polarity of hookup as shown, the comparator will be high until the ramp voltage equals the input

voltage, at which time it will transition low. A counter gate is generated by the AND of the PWM high time (which defines the start of the ramp) and the comparator (which defines the trip point or the end of the conversion for a given voltage). When the conversion is complete, the code may be read from the counter. Each column has an ADC configuration register (ADCx_CR).

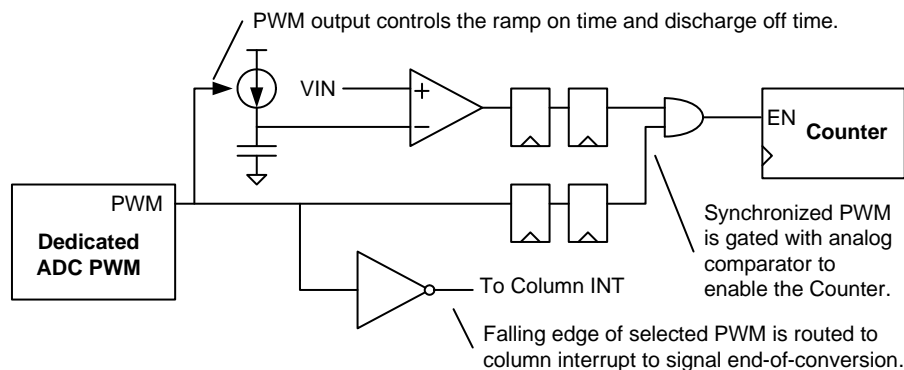

Figure 24-2. Single Slope ADC Block Diagram

In order to interface the asynchronous analog comparator to the digital block array, a double synchronization is required. As shown in Figure 24-2, the PWM is also delayed to align with the valid comparator output.

The basic conversion waveforms are shown in Figure 24-3. The high time of the PWM is set so that the counter will count to a full-scale value. For example, for 8-bit resolution, the high time of the PWM would correspond to 255 (or 256) counter clocks. The low time of the PWM is designed to allow the capacitor to discharge. When a PWM is used for

continuous conversions, the Terminal Count of the PWM can be used as a consistent interrupt to read the result of the previous conversion. If only a single conversion is desired, the comparator trip point can be used as an interrupt to signal the end of conversion.

A trim register (ADCx_TR) is provided for each column. The converter must be calibrated for a given maximum voltage, resolution, and frequency of operation before use.

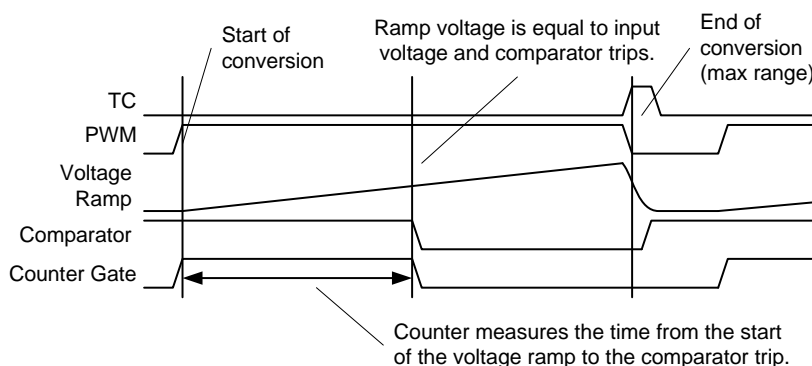

Figure 24-3. Basic ADC Waveforms

24.1.1.4 PWM ADC Interface

The analog interface provides hardware support and signal routing for **analog-to-digital (ADC)** conversion functions, specifically the single slope ADC. The control signals for this interface are split between three registers: DEC_CR0, DEC_CR1, and PWM_CR.

The analog interface has support for the single slope ADC operation through the ability to gate the analog comparator outputs. This gating function is required in order to precisely control the digital integration period that is performed in a digital block as part of the function. A digital block PWM or the dedicated ADC PWM may be used as a source to provide the gate signal. Only one source for the gating signal can be selected. However, the gating can be applied independently to any of the column comparator outputs.

The CY8C21x34, CY8C21x23, CY7C603xx, and CYWUSB6953 devices contain a dedicated block that can perform this PWM gating function using VC3. The VC3 signal, out of the VC3 divider block, can be further divided to provide for gating the incremental ADC.

The PWM_CR register controls the duty cycle selection in terms of VC3 periods, as shown in the following tables. When enabled, the PWM block becomes the source for the incremental gating, overriding the digital block selection.

Table 24-3. PWM High Time

HI[2:0]	Description
000b	Block is not selected, input to incremental gate is from selected digital block.
001b	High time is 1 VC3 period.
010b	High time is 2 VC3 period.
011b	High time is 4 VC3 period.
100b	High time is 8 VC3 period.
101b	High time is 16 VC3 period.

Table 24-4. PWM Low Time

LO[1:0]	Description
00b	No low time. Comparator gate is continually high.
01b	Low time is one VC3 period.
10b	Low time is two VC3 period.
11b	Low time is three VC3 period.

As an alternative to the PWM, the ICLKS bits, which are split between the DEC_CR0 and DEC_CR1 registers, may be used to select a digital block source for the incremental gating signal. Regardless of the source of the gating, the two IGEN bits are used to independently enable the gating function on a column-by-column basis.

24.1.1.5 Analog Modulator Interface (Mod Bits)

The Analog Modulator Interface provides a selection of signals that are routed to either of the two analog array modulation control signals. There is one modulation control signal for each CY8C21x34, CY8C21x23, CY7C603xx, and CYWUSB6953 Switched Capacitor block. There are six selections, which include the analog comparator bus outputs, two global outputs, and a digital block broadcast bus. The selections for all columns are contained in the AMD_CR0 and AMD_CR1 registers.

One use of the modulator interface is to provide a selectable reference to one of the comparator inputs. This can be done by configuring a digital block as a PWM or PRS output with the desired duty cycle. The SC block will then give a low-pass filtered version of this signal, which will be a DC voltage relative to the supply with some ripple.

24.1.1.6 Sample and Hold Feature

Sample and Hold capability can be selected for improved analog-to-digital conversion accuracy. This is done by setting the SHEN bit in the ADCx_CR register.

When enabled, this feature works in conjunction with the selected SSADC PWM input. During the PWM high time, the conversion is active and the sample and hold is in “hold” mode. During the PWM low time, the conversion is inactive, and the sample and hold circuit is in “sample” mode.

24.1.2 Analog Array

The analog array is designed to allow moving between families without modifying projects, except for resource limitations. The CY8C21x34, CY8C21x23, CY7C603xx, and CYWUSB6953 PSoC devices have limited analog array functionality. The only analog array connections available to the CY8C21x34, CY8C21x23, CY7C603xx, and CYWUSB6953 are the NMux and PMux connections. Figure 24-4 displays the analog arrays for the CY8C21x34, CY8C21x23, CY7C603xx, and CYWUSB6953 devices, containing the type E continuous time blocks (ACE) and the type E switched capacitor blocks (ASE). Each analog column has 2 analog blocks associated with it. The figures that follow illustrate the analog multiplexer (mux) connections.

Each analog column has a dedicated comparator bus associated with it. Only the CT block in each column can drive this bus. When the CT block is not configured as a comparator, a zero is driven to the comparator block. Refer to the ACBxxCR1 register on page 190 and the “Analog Comparator Bus Interface” on page 432 in the Analog Interface section for more information.

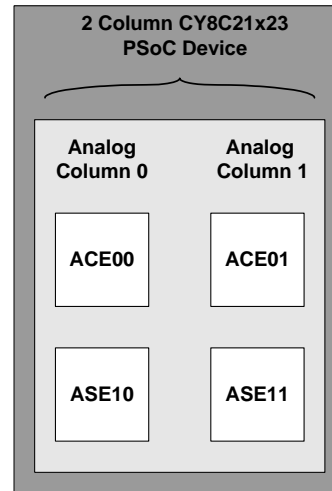

Figure 24-4. Array of Analog PSoC Blocks for the CY8C21x34, CY8C21x23, CY7C603xx, and CYWUSB6953 PSoC Devices

24.1.2.1 NMux Connections

The NMux is an 8-to-1 mux which determines the source for the inverting (also called negative) input of Continuous Time (CT) PSoC blocks. These blocks are named ACE00 and ACE01 in the CY8C21x34, CY8C21x23, CY7C603xx, and CYWUSB6953 PSoC devices. More details on the CT PSoC blocks are available in this chapter, in the section titled “Continuous Time PSoC Block” on page 441. The NMux connections are described in detail in the ACExxCR1 register on page 192, bits NMux[2:0]. The numbers in Figure 24-5, which are associated with each arrow, are the corresponding NMux select line values for the data in the NMux portion of the register. The call out names in the figure show nets selected for each NMux value.

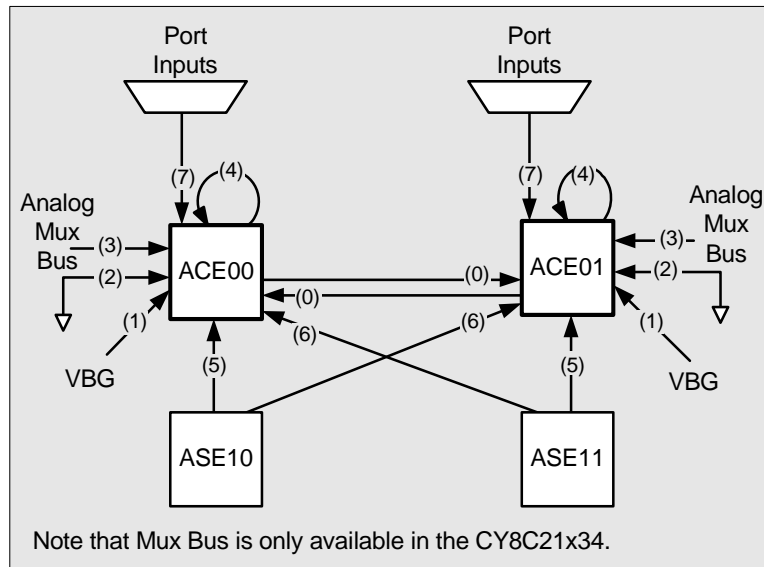

Figure 24-5. NMux Connections for the CY8C21x34, CY8C21x23, CY7C603xx, and CYWUSB6953 PSoC Devices

24.1.2.2 PMux Connections

The PMux is an 8-to-1 mux which determines the source for the non-inverting (also called positive) input of CT PSoC blocks (ACE00 and ACE01). More details on the CT PSoC blocks are available in this chapter, in the section titled “[Continuous Time PSoC Block](#)” on page 441. The PMux connections are described in detail in the [ACExxCR1 register](#) on page 192, bits PMux[2:0]. The numbers in [Figure 24-6](#), which are associated with each arrow, are the corresponding PMux select line values for the data in the PMux portion of the register. The call out names in the figure show nets selected for each PMux value.

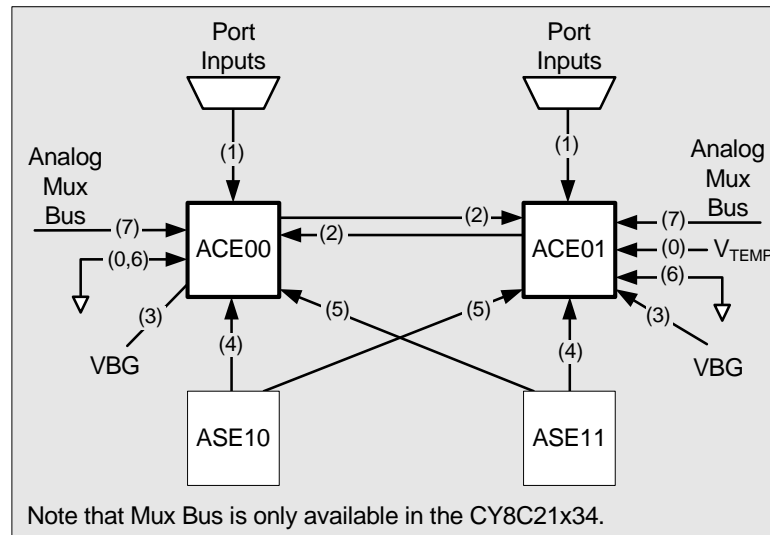

Figure 24-6. PMux Connections for the CY8C21x34, CY8C21x23, CY7C603xx, and CYWUSB6953 PSoC Devices

24.1.2.3 Temperature Sensing Capability

A temperature-sensitive voltage, derived from the bandgap sensing on the die, is buffered and available as an analog input into the continuous time block ACE01. Temperature sensing allows protection of device operating ranges for fail-safe applications. Temperature sensing, combined with a long sleep timer interval (to allow the die to approximate **ambient temperature**), can give an approximate ambient temperature for data acquisition and battery charging applications. The user may also calibrate the internal temperature rise based on a known current consumption.

The temperature sensor input to the ACE01 block is labeled V_{TEMP} .

24.1.3 Analog Input Configuration

[Figure 24-8](#) and [Figure 24-9](#) show the analog input configuration for the CY8C21x34, CY8C21x23, CY7C603xx, and CYWUSB6953 PSoC devices, respectively. For a detailed description of the IO analog multiplexer functionality illustrated in [Figure 24-8](#), refer to the [IO Analog Multiplexer](#) chapter on page 517.

The input multiplexer (mux) maps device inputs (package pins) to analog array columns, based on bit values in the [AMX_IN](#) and [ABF_CR0](#) registers. Column 0 is fed by one 4-to-1 mux; column 1 is fed by one of two 4-to-1 muxes. The muxes are CMOS switches with typical resistances in the range of 2K ohms.

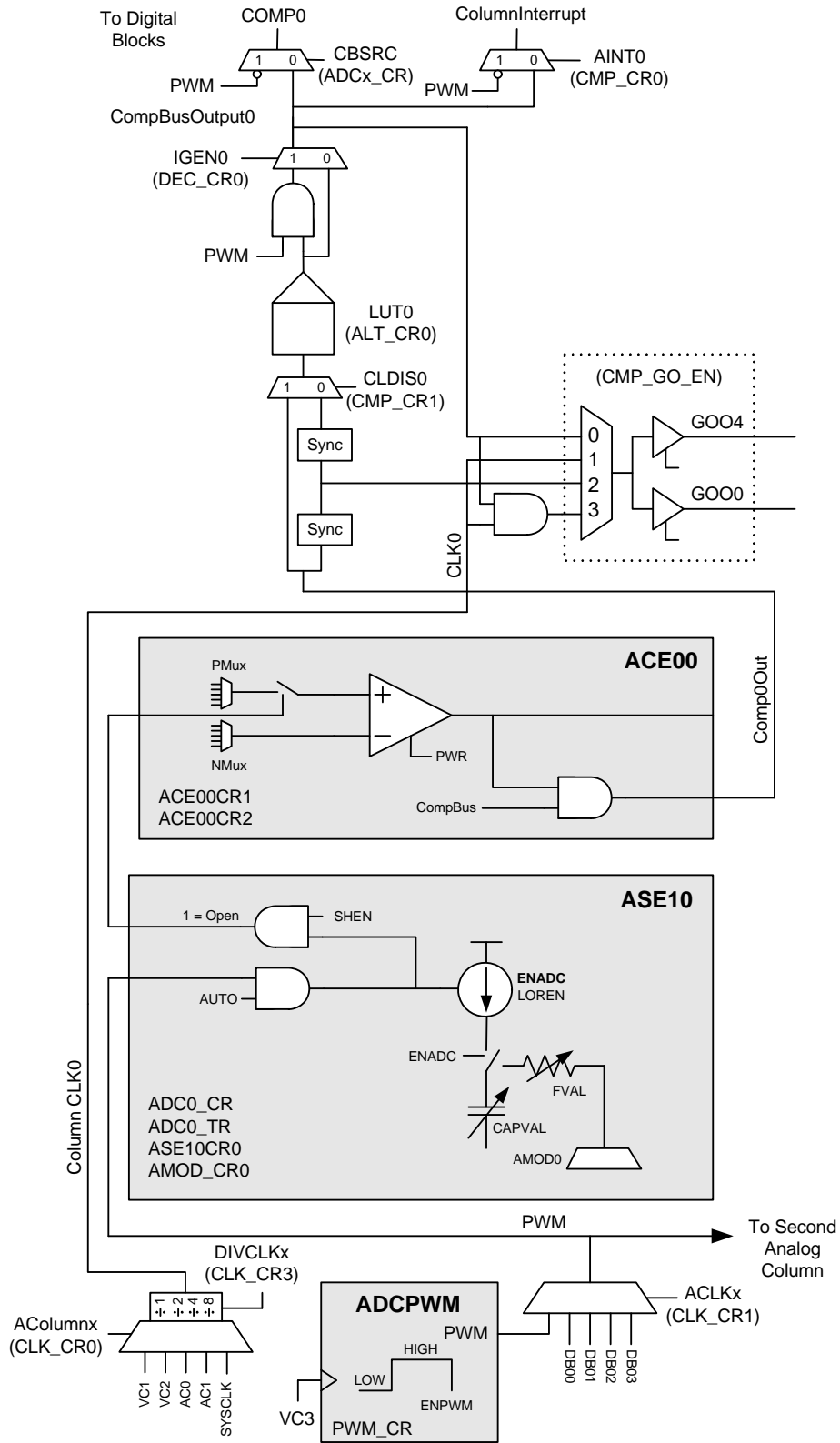

Figure 24-7. Limited Two Column Analog Interconnect

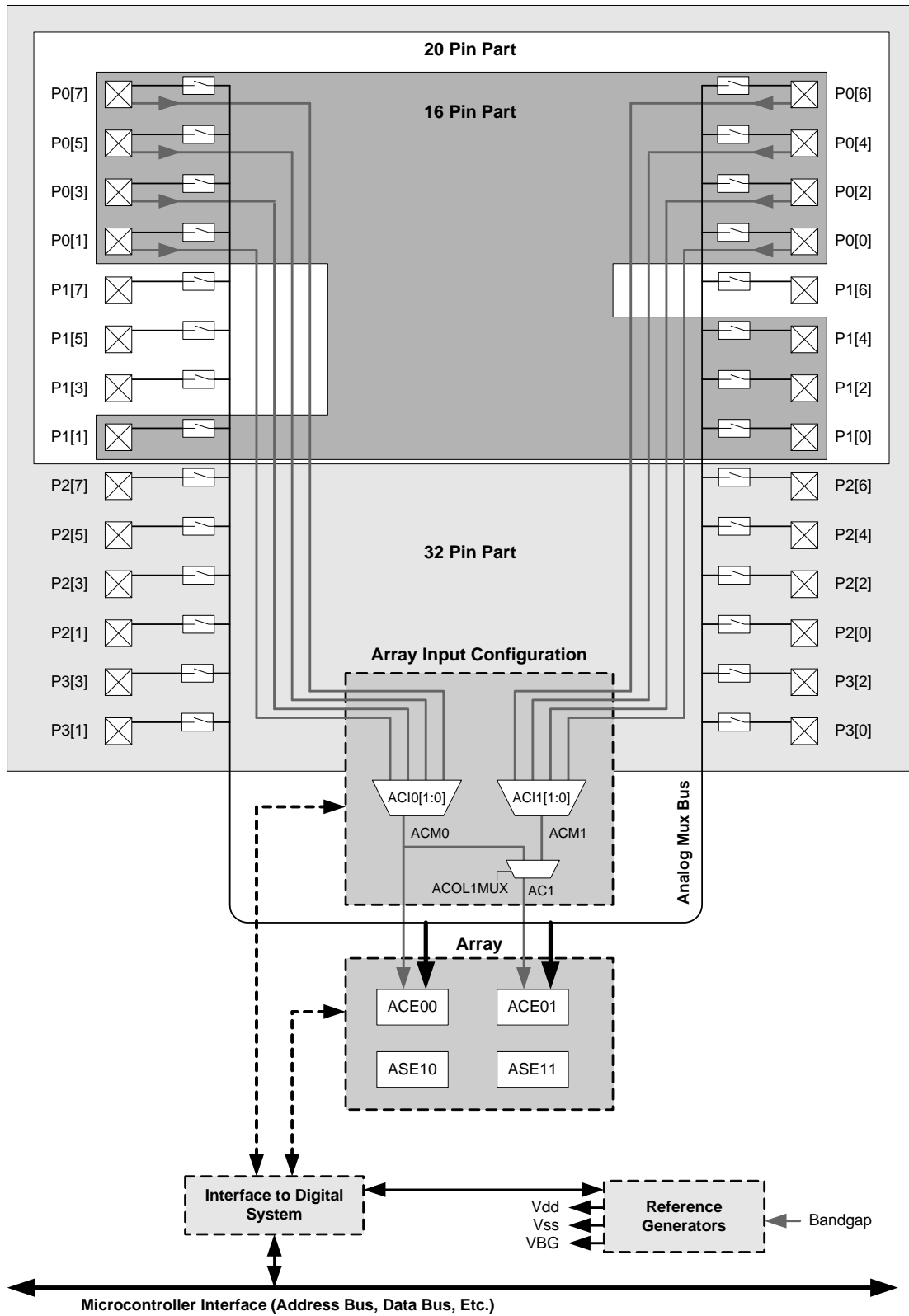

Figure 24-8. Two Column Limited Analog Pin Block Diagram for the CY8C21x34, CY7C603xx, and CYWUSB6953

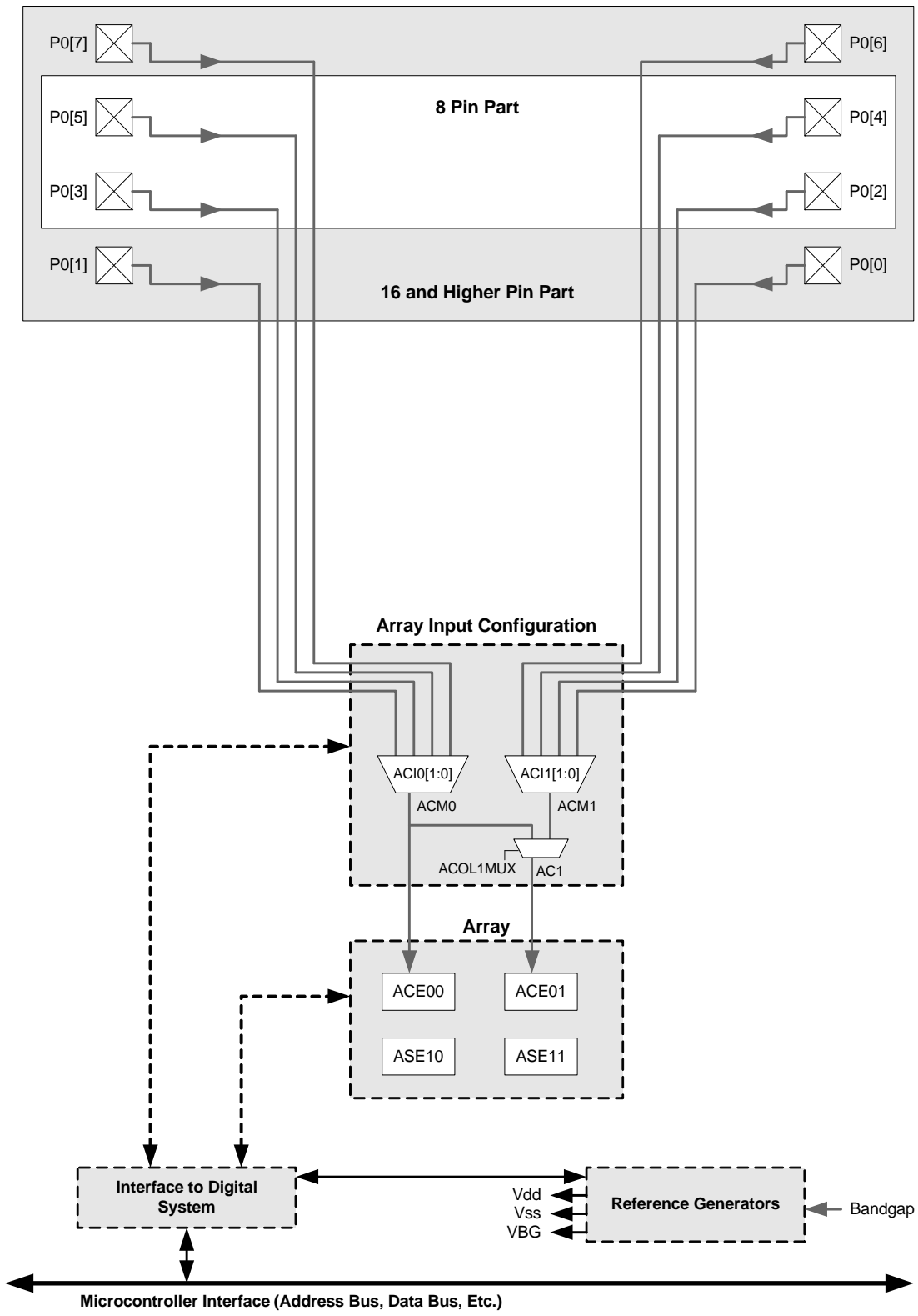

Figure 24-9. Two Column Limited Analog Pin Block Diagram for the CY8C21x23

24.1.4 Analog Reference

The PSoC device is a single supply part, with no negative voltage available or applicable. The CY8C21x34, CY8C21x23, CY7C603xx, and CYWUSB6953 PSoC devices support only one analog reference, which is the bandgap voltage VBG. This voltage is routed to the CT blocks in each analog column. VBG is available at both positive and negative inputs of each CT amplifier.

DAC functions are relative to the power supply range (V_{SS} to V_{DD}). The bandgap VBG reference can be used to calibrate the supply range. Single slope ADC operation relies on a calibration step, using the internal bandgap reference or other user-supplied reference. If the bandgap reference is used, the ADC gives absolute voltage conversions.

For CT amplifiers configured as comparators (that is, open loop), a selected analog pin can be compared against another pin (fed from the other block), VBG, or a supply-referenced DAC voltage from the SC integrator. With the analog multiplexer bus in the CY8C21x34, CY7C603xx, and CYWUSB6953 PSoC devices, a Port 0 pin can be compared against another pin without using resources of the adjacent column.

24.1.5 Continuous Time PSoC Block

The CY8C21x34, CY8C21x23, CY7C603xx, and CYWUSB6953 Continuous Time blocks (Type ACE) are built around a low power, low offset amplifier. The CT block can be configured in two modes: As a unity gain buffer to drive to the other column or open loop as a comparator.

To configure as a comparator, select any NMux choice except feedback (FB). To enable the comparator bus output, the CompBus signal must be set in the ACE0xCR1 register. See Figure 24-10.

There are two discrete outputs from this block. These outputs connect to the following buses:

1. The comparator bus (CBUS), which is a digital bus that is a resource shared by all of the analog blocks in a column for that block. This output is available to system interface logic.
2. The local output bus (OUT), which is routed to the neighboring block.

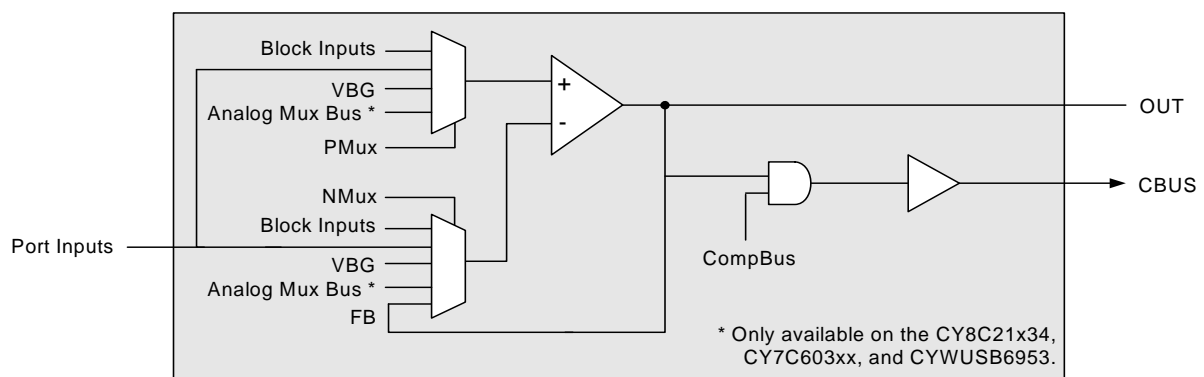

Figure 24-10. Analog Continuous Time Block Diagram for CY8C21x34, CY8C21x23, CY7C603xx, and CYWUSB6953 PSoC Devices

24.1.6 Switched Capacitor PSoC Block

The analog switched capacitor blocks accept a bit stream from either a digital block or a CT comparator. The SC block integrates this input and its output can then be connected to a CT block.

The low power SC block, in the CY8C21x34, CY8C21x23, CY7C603xx, and CYWUSB6953 (Type ASE), is automatically enabled whenever the CT block is powered up. Refer to the ACB0xCR2 register definition in this chapter.

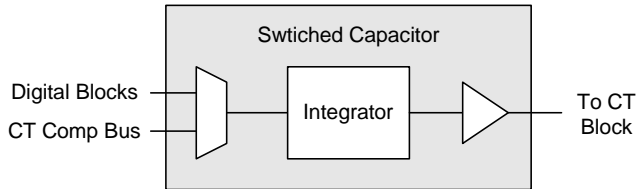

Figure 24-11. Analog Switch Capacitor PSoC Block for the CY8C21x34, CY8C21x23, CY7C603xx, and CYWUSB6953 PSoC Devices

24.1.6.1 Application Description for the SC Block

The Analog Switched Capacitor (SC) blocks support DACs for comparator references. This application requires the use of one CT block. Analog-to-digital conversions can be done with a firmware-based successive approximation algorithm, using the SC block to provide a DAC reference.

The integrator speed can be modified to trade off accuracy for settling time.

24.2 PSoC Device Distinctions

The following are PSoC device distinctions for the CY8C21x34, CY8C21x23, CY7C603xx, and CYWUSB6953 PSoC devices.

- The continuous time (CT) blocks in the CY8C21x34, CY8C21x23, CY7C603xx, and CYWUSB6953 PSoC devices differ from other PSoC Programmable System-on-Chip devices in the following ways:
 - The CT amplifier can only be configured as unity gain or open loop (comparator).
 - No separate low power comparator is available; however, this CT block amplifier is inherently low power and may be useful as a sleep mode comparator in many applications.
 - The column comparator bus is always driven from the CT block. When the CT amplifier is configured in Unity Gain mode, CompBus should be set to zero and the block outputs a zero on the comparator bus.
- In the CY8C21x34, CY8C21x23, CY7C603xx, and CYWUSB6953 PSoC devices, the switched capacitor (SC) block consists of a low power integrator that is enabled whenever the CT block is enabled. It can be used to create a DAC reference for a CT comparator. The only configuration of the internal state of the SC block available to the user is input and output connections, and integrator speed by way of the FCap register bit.
- The CY8C21x34, CY8C21x23, CY7C603xx, and CYWUSB6953 PSoC devices can use a VC3-based control for analog-to-digital conversion.
- For the CY8C21x34, CY7C603xx, and CYWUSB6953 PSoC devices, all GPIO pins can connect to the internal analog mux bus.
- The temperature sensor input (V_{TEMP}) is connected through the ACE01 PMux. There is no special ground reference for the signal.

24.3 Register Definitions

The following registers are associated with the CY8C21x34, CY8C21x23, CY7C603xx, and CYWUSB6953 PSoC devices and are listed in address order within their system resource configuration. The registers that are exclusive to the CY8C21x34, CY7C603xx, and CYWUSB6953 are summarized in the “Summary Table of the System Resource Registers” on page 455 and detailed in the IO Analog Multiplexer chapter on page 517. For a complete table of all analog system registers for all other PSoC devices, refer to the “Summary Table of the Analog Registers” on page 373.

Each register description has an associated register table showing the bit structure for that register. Register bits that are grayed out throughout this document are reserved bits and are not detailed in the register descriptions that follow.

24.3.1 Summary Table for 2 Column Limited Analog System Registers

The table below lists the registers that are used by the CY8C21x34, CY8C21x23, CY7C603xx, and CYWUSB6953 PSoC devices, in address order within their system resource configuration. Note that there are no registers associated with the CY8C21x34, CY8C21x23, CY7C603xx, and CYWUSB6953 for the analog reference, since there are no configuration options for that function. The bits that are grayed out are reserved bits. Reserved bits should always be written with a value of '0'.

Table 24-5. Summary Table for 2 Column Limited Analog System Registers

Address	Register Name	Bit 7	Bit 6	Bit 5	Bit 4	Bit 3	Bit 2	Bit 1	Bit 0	Access : POR Value	
ANALOG INTERFACE REGISTERS (page 444)											
0,62h	PWM_CR			HIGH[2:0]			LOW[1:0]		PWMEN	R : 00	
0,64h	CMP_CR0			COMP[1:0]			AINT[1:0]			R : 00	
0,66h	CMP_CR1			CLDIS[1:0]						RW : 00	
0,68h	ADC0_CR	CMPST	LOREN	SHEN		CBSRC	AUTO		ADCEN	# : 00	
0,69h	ADC1_CR	CMPST	LOREN	SHEN		CBSRC	AUTO		ADCEN	# : 00	
0,E6h	DEC_CR0			IGEN[1:0]		ICLKS0				RW : 00	
0,E7h	DEC_CR1				ICLKS2	ICLKS1				RW : 00	
1,60h	CLK_CR0					AColumn1[1:0]		AColumn0[1:0]		RW : 00	
1,61h	CLK_CR1			ACLK1[1:0]			ACLK0[1:0]			RW : 00	
1,63h	AMD_CR0						AMOD0[3:0]			RW : 00	
1,64h	CMP_GO_EN	GOO5	GOO1	SEL1[1:0]		GOO4	GOO0	SEL0[1:0]		RW : 00	
1,66h	AMD_CR1						AMOD1[3:0]			RW : 00	
1,67h	ALT_CR0		LUT1[3:0]			LUT0[3:0]				RW : 00	
1,6Bh	CLK_CR3		SYS1	DIVCLK1[1:0]			SYS0	DIVCLK0[1:0]		RW : 00	
1,E5h	ADC0_TR	CAPVAL_[7:0]								RW : 00	
1,E6h	ADC1_TR	CAPVAL_[7:0]								RW : 00	
ANALOG INPUT CONFIGURATION REGISTERS (page 449)											
0,60h	AMX_IN					ACI1[1:0]		ACI0[1:0]		RW : 00	
1,62h	ABF_CR0	ACol1Mux									RW : 00
CONTINUOUS TIME PSoC BLOCK, TYPE E, REGISTERS (page 450)											
x,72h *	ACE00CR1		CompBus	NMux[2:0]			PMux[2:0]			RW : 00	
x,73h *	ACE00CR2						FullRange	PWR		RW : 00	
x,76h *	ACE01CR1		CompBus	NMux[2:0]			PMux[2:0]			RW : 00	
x,77h *	ACE01CR2						FullRange	PWR		RW : 00	
SWITCHED CAPACITOR PSoC BLOCK, TYPE E, REGISTERS (page 451)											
x,80h *	ASE10CR0	FVal									RW : 00
x,84h *	ASE11CR0	FVal									RW : 00

LEGEND

x An “x” before the comma in the address field indicates that this register can be accessed or written to no matter what bank is used.

Access is bit specific. Refer to the Register Details chapter on page 147.

* Address has a dual purpose, see “Mapping Exceptions” on page 141.

24.3.2 Analog Interface Registers

PWM_CR Register

Address	Name	Bit 7	Bit 6	Bit 5	Bit 4	Bit 3	Bit 2	Bit 1	Bit 0	Access
0,62h	PWM_CR			HIGH[2:0]			LOW[1:0]		PWMEN	R : 00

The ADC PWM Control Register (PWM_CR) controls the parameters for the dedicated ADC PWM. This PWM function uses VC3 as its input clock so all periods are in terms of VC3 terminal counts.

Bits 5 to 3: HIGH[2:0]. These bits set the PWM high time in terms of VC3 periods.

Bits 2 and 1: LOW[1:0]. These bits set the PWM low time in terms of VC3 periods.

Bit 0: PWMEN. This bit starts and stops the PWM. When this bit is disabled, the PWM output state is always low.

When this bit is enabled, the following two scenarios can occur:

1. If the low time programmed is greater than 0, the PWM waits for the first VC3 terminal count before starting the low time count.
2. If the low time programmed is 0, the PWM will wait for the first VC3 terminal count before going high, and then will start counting VC3 periods for the purpose of generating the PWM terminal count. The PWM will stay high continually until enabled.

For additional information, refer to the [PWM_CR register on page 178](#).

CMP_CR0 Register

Address	Name	Bit 7	Bit 6	Bit 5	Bit 4	Bit 3	Bit 2	Bit 1	Bit 0	Access
0,64h	CMP_CR0			COMP[1:0]				AINT[1:0]		R : 00

The Analog Comparator Bus 0 Register (CMP_CR0) is used to poll the analog column comparator bits and select column interrupts.

Bits 5 and 4: COMP[1:0]. These bits are the read only bits corresponding to the comparator bits in each analog column. By default, they are synchronized to the column clock and thus may be reliably polled by the CPU.

Bits 1 and 0: AINT[1:0]. These bits choose between the analog column data and the dedicated incremental PWM terminal count as the analog interrupt source for this column.

For additional information, refer to the [CMP_CR0 register on page 180](#).

CMP_CR1 Register

Address	Name	Bit 7	Bit 6	Bit 5	Bit 4	Bit 3	Bit 2	Bit 1	Bit 0	Access
0.66h	CMP_CR1			CLDIS[1:0]						RW : 00

The Analog Comparator Bus 1 Register (CMP_CR1) is used to override the analog column comparator synchronization.

Bits 5 and 4: CLDIS[1:0]. The CLDIS bits are used to override the analog column comparator synchronization. When these bits are set, the given column is not synchronized by the column clock. This capability is typically used to

allow a continuous time comparator result to propagate directly to the interrupt controller during sleep. Since the master clocks (except the 32 kHz clock) are turned off during sleep, the synchronizer must be bypassed.

For additional information, refer to the [CMP_CR1 register on page 183](#).

ADCx_CR Register

Address	Name	Bit 7	Bit 6	Bit 5	Bit 4	Bit 3	Bit 2	Bit 1	Bit 0	Access
0.68h	ADC0_CR	CMPST	LOREN	SHEN		CBSRC	AUTO		ADCEN	# : 00
0.69h	ADC1_CR	CMPST	LOREN	SHEN		CBSRC	AUTO		ADCEN	# : 00

The ADC Column 0 and Column 1 Configuration Register (ADCx_CR) controls the single slope ADC in each column.

Bit 7: CMPST. This bit is a read only status bit. It provides information at the end of an ADC conversion as to whether the analog comparator tripped or did not trip. This can be used to provide an over-range bit. For example, the range of an 8-bit conversion is 0 – 255, 256 codes. However, in order to achieve this range exactly, the PWM high time must define 255 clocks (0 clocks corresponding to a 0 ADC result). This is possible for a digital block PWM which has an arbitrary high and low time programming with respect to the input clock. However, since the dedicated ADC PWM has only a limited number of divide selections based on the VC3 period, the high time will normally be in powers of two. For example, in an 8-bit conversion, the PWM ADC will be set for 256 clocks, rather than 255, and this gives an extra code of 0 to 256. For the 256th code, the 8-bit counter value will roll over and therefore be indistinguishable from code 0. However, the CMPST bit will indicate that this is actually the 256th code.

Bit 6: LOREN. This bit controls the range of the base current level of the ADC. A '0' in this bit position is the normal current range. A '1' in this bit selects the low current range that divides the current by an approximate factor of four.

Bit 5: SHEN. This bit controls sample and hold. When this bit is set to '1', sample and hold is enabled and controlled by the ADC PWM selection if the AUTO mode bit is set. When this bit is set to '0', sample and hold is disabled, and the comparator voltage input follows the input pin to which it is connected.

Bit 3: CBSRC. This bit controls the source of the comparator bus output to the digital blocks. By default, when this bit is '0', the synchronized analog comparator output is the source for the digital comparator bus. When this bit is set to '1', the selected PWM terminal count becomes the digital comparator bus source. In ADC operating mode, this bit is set to '1' to implement Timer Capture digital interface and set to '0' to implement Counter Enable digital interface.

Bit 2: AUTO. When enabled, this bit allows the conversion to be controlled by a selected PWM signal.

Bit 0: ADCEN. By default, the ADC circuit is powered down. When the ADCEN bit is set to '1', the circuit is ready for use. The ADCEN bit must be set as part of the initial configuration, before enabling the PWM in AUTO mode.

For additional information, refer to the [ADCx_CR register on page 185](#).

DEC_CR0 Register

Address	Name	Bit 7	Bit 6	Bit 5	Bit 4	Bit 3	Bit 2	Bit 1	Bit 0	Access
0,E6h	DEC_CR0			IGEN[1:0]		ICLKS0				RW : 00

The Decimator Control Register 0 (DEC_CR0) contains control bits to access hardware support for ADC operation.

Bits 5 and 4: IGEN[1:0]. For single slope ADC (SSADC) support, IGEN[1:0] selects which column comparator bit will be gated by the output of the dedicated ADC PWM or a digital block. The high time of the PWM source corresponds to the ADC conversion period. This ensures that the comparator output is only processed for the precise conversion time. If a digital block is selected for the gating function, it is con-

trolled by ICLKS0 in this register, and ICLKS2 and ICLKS1 in the DEC_CR1 register.

Bit 3: ICLKS0. In conjunction with ICLKS1 in the DEC_CR1 register, these bits select up to one of four digital blocks to provide the gating signal for an SSADC conversion.

For additional information, refer to the [DEC_CR0 register on page 245](#).

DEC_CR1 Register

Address	Name	Bit 7	Bit 6	Bit 5	Bit 4	Bit 3	Bit 2	Bit 1	Bit 0	Access
0,E7h	DEC_CR1				ICLKS2	ICLKS1				RW : 00

The Decimator Control Register 1 (DEC_CR1) is used to configure signals for ADC operation.

Bits 4 and 3: ICLKSx. The ICLKS1 and ICLKS2 bits in this register select the digital block sources for SSADC hardware support (see the DEC_CR0 register).

For additional information, refer to the [DEC_CR1 register on page 247](#).

CLK_CR0 Register

Address	Name	Bit 7	Bit 6	Bit 5	Bit 4	Bit 3	Bit 2	Bit 1	Bit 0	Access
1,60h	CLK_CR0					AColumn1[1:0]		AColumn0[1:0]		RW : 00

The Analog Column Clock Control Register 0 (CLK_CR0) is used to select the clock source for an individual analog column.

Bits 3 to 0: AColumnx[1:0]. An analog column clock generator is provided for each column. The bits in this register select the source for each column clock generator.

There are four selections for each clock: VC1, VC2, ACLK0, and ACLK1. VC1 and VC2 are the programmable global system clocks. ACLK0 and ACLK1 sources are each selected from up to one of four digital block outputs (functioning as clock generators) as selected by CLK_CR1.

For additional information, refer to the [CLK_CR0 register on page 265](#).

CLK_CR1 Register

Address	Name	Bit 7	Bit 6	Bit 5	Bit 4	Bit 3	Bit 2	Bit 1	Bit 0	Access
1,61h	CLK_CR1				ACLK1[1:0]			ACLK0[1:0]		RW : 00

The Analog Column Clock Control Register 1 (CLK_CR1) selects the clock source for an individual analog column.

Bits 4, 3 and 1, 0: ACLKx[1:0]. There are two 2-bit fields in this register that can select up to one of four digital blocks, to function as the clock source for ACLK0 and ACLK1.

ACLK0 and ACLK1 are alternative clock inputs to the analog column clock generators (see the CLK_CR0 register above).

For additional information, refer to the [CLK_CR1 register on page 266](#).

AMD_CR0 Register

Address	Name	Bit 7	Bit 6	Bit 5	Bit 4	Bit 3	Bit 2	Bit 1	Bit 0	Access
1,63h	AMD_CR0					AMOD0[3:0]				RW : 00

The Analog Modulation Control Register 0 (AMD_CR0) is used to select the modulator bits used with each column.

Bits 3 to 0: AMOD0[3:0]. These bits control the selection of the MODBITs for analog column 0. The MODBIT is a modulated data stream input into a Switched Capacitor block. Three bits for each column allow a one of eight selec-

tion for the MODBIT. Sources include any of the analog column comparator buses, two global buses, and one broadcast bus. The default for this function is zero or off.

For additional information, refer to the [AMD_CR0 register on page 269](#).

CMP_GO_EN Register

Address	Name	Bit 7	Bit 6	Bit 5	Bit 4	Bit 3	Bit 2	Bit 1	Bit 0	Access
1,64h	CMP_GO_EN	GOO5	GOO1	SEL1[1:0]		GOO4	GOO0	SEL0[1:0]		RW : 00

The Comparator Bus to Global Outputs Enable Register (CMP_GO_EN) controls options for driving the analog comparator bus and column clock to the global bus.

This register is also used by the CY8C24x94 and CY7C64215 PSoC devices.

Bit 7: GOO5. This bit drives the selected column 1 signal to GOO5.

Bit 6: GOO1. This bit drives the selected column 1 signal to GOO1.

Bits 5 and 4: SEL1[1:0]. These bits select the column 1 signal to output.

Bit 3: GOO4. This bit drives the selected column 0 signal to GOO4.

Bit 2: GOO0. This bit drives the selected column 0 signal to GOO0.

Bits 1 and 0: SEL0[1:0]. These bits select the column 0 signal to output.

For additional information, refer to the [CMP_GO_EN register on page 271](#).

AMD_CR1 Register

Address	Name	Bit 7	Bit 6	Bit 5	Bit 4	Bit 3	Bit 2	Bit 1	Bit 0	Access
1,66h	AMD_CR1					AMOD1[3:0]				RW : 00

The Analog Modulation Control Register 1 (AMD_CR1) is used to select the modulator bits used with each column.

For additional information, refer to the [AMD_CR1 register on page 273](#).

Bits 3 to 0: AMOD1[3:0]. These bits control the selection of the MODBITS for analog column 1. See the AMD_CR0 register above.

ALT_CR0 Register

Address	Name	Bit 7	Bit 6	Bit 5	Bit 4	Bit 3	Bit 2	Bit 1	Bit 0	Access
1,67h	ALT_CR0	LUT1[3:0]				LUT0[3:0]				RW : 00

The Analog LUT Control Register 0 (ALT_CR0) is used to select the logic function.

[Table 24-1](#) shows the available functions, where the A input applies to the selected column, and the B input applies to the next most significant neighbor column. Column 0 settings apply to combinations of column 0 and column 1. Column 1 settings apply to column 1 with B=0.

Bits 7 to 4 and 3 to 0: LUTx[3:0]. These bits control the selection of logic functions that may be selected for the analog comparator bits in column 0 and column 1. A one of 16 look-up table (LUT) is applied to the outputs of each column comparator bit and optionally a neighbor bit to implement two input logic functions.

For additional information, refer to the [ALT_CR0 register on page 275](#).

CLK_CR3 Register

Address	Name	Bit 7	Bit 6	Bit 5	Bit 4	Bit 3	Bit 2	Bit 1	Bit 0	Access
1,6Bh	CLK_CR3		SYS1	DIVCLK1[1:0]			SYS0	DIVCLK0[1:0]		RW : 00

The Analog Clock Source Control Register 3 (CLK_CR3) controls additional options for analog column clock generation. It allows an option for selecting SYSCLK directly as the column clock source, as well as additional divide values on the selected source.

Bits 5 and 4: DIVCLK1[1:0]. These bits control an optimal divide value on the selected clock in column 1.

Bit 6: SYS1. This bit selects SYSCLK as the source for the analog column 1 clocking.

Bit 2: SYS0. This bit selects SYSCLK as the source for the analog column 0 clocking.

Bits 1 and 0: DIVCLK0[1:0]. These bits control an optimal divide value on the selected clock in column 0.

For additional information, refer to the [CLK_CR3 register on page 279](#).

ADCx_TR Register

Address	Name	Bit 7	Bit 6	Bit 5	Bit 4	Bit 3	Bit 2	Bit 1	Bit 0	Access
1,E5h	ADC0_TR	CAPVAL_[7:0]								RW : 00
1,E6h	ADC1_TR	CAPVAL_[7:0]								RW : 00

The ADC Column 0 and Column 1 Trim Register (ADCx_TR) controls a combination of capacitor and current values that determine the slope of the ADC voltage ramp.

Bits 7 to 0: CAPVAL_[7:0]. These bits are used to calibrate the ADC. Before the converter can be used, the capacitor array must be calibrated with a known voltage (for example, the bandgap voltage). The goal of this calibration process is to tune the ramp time (slope) such that the full-scale ADC input value results in a full-scale ADC code. This

is accomplished by matching the ramp time to the desired full-scale conversion period, which is dependent on clock rate and resolution. The bits of the register have an inverted sense; that is, a '1' reduces the capacitance which increases the speed of the ramp and a '0' increases the capacitance which decreases the speed of the ramp.

For additional information, refer to the [ADCx_TR register on page 296](#).

24.3.3 Analog Input Configuration Registers

AMX_IN Register

Address	Name	Bit 7	Bit 6	Bit 5	Bit 4	Bit 3	Bit 2	Bit 1	Bit 0	Access
0,60h	AMX_IN					AC11[1:0]		AC10[1:0]		RW : 00

The Analog Input Select Register (AMX_IN) controls the analog muxes that feed signals in from port pins into the analog column.

Bits 3 to 0: AC1x[1:0]. The AC11[1:0] and AC10[1:0] bits control the analog muxes that feed signals in from port pins into the analog column. The analog column can have up to

eight port bits connected to its muxed input. AC11 and AC10 are used to select among even and odd pins. The AC1Mux bit field controls the bits for those muxes and is located in the Analog Output Buffer Control Register (ABF_CR0).

For additional information, refer to the [AMX_IN register on page 175](#).

ABF_CR0 Register

Address	Name	Bit 7	Bit 6	Bit 5	Bit 4	Bit 3	Bit 2	Bit 1	Bit 0	Access
1,62h	ABF_CR0	ACol1Mux								RW : 00

The Analog Output Buffer Control Register 0 (ABF_CR0) controls analog input muxes from Port 0.

Bit 7: ACol1MUX. A mux selects the output of column 0 input mux or column 1 input mux. When set, this bit sets the column 1 input to column 0 input mux output.

For additional information, refer to the [ABF_CR0 register on page 267](#).

24.3.4 Continuous Time PSoC Block Registers

The naming convention for the continuous time registers and their arrays of PSoC blocks is <Prefix>mn<Suffix>, where m=row index and n=column index. Therefore, ACE01CR2 (written ACExxCR2) is a register for an analog PSoC block in row 0 column 1.

ACExxCR1 Register

Address	Name	Bit 7	Bit 6	Bit 5	Bit 4	Bit 3	Bit 2	Bit 1	Bit 0	Access
x,72h *	ACE00CR1		CompBus	NMux[2:0]			PMux[2:0]			RW : 00
x,76h *	ACE01CR1		CompBus	NMux[2:0]			PMux[2:0]			RW : 00

LEGEND

x An "x" before the comma in the address field indicates that this register can be accessed or written to no matter what bank is used.

* Address has a dual purpose, see "Mapping Exceptions" on page 141.

The Analog Continuous Time Type E Block Control Register 1 (ACExxCR1) is one of two registers used to configure the type E continuous time PSoC block.

Bit 6: CompBus. This bit determines whether the comparator bus is driven from the amplifier output or driven low. If the CT block is configured in Unity Gain mode, this bit should be set to zero so the comparator bus is driven low.

Bits 5 to 3: NMux[2:0]. These bits control the multiplexing of inputs to the inverting input of the opamp. There are several input choices from outside the block, plus an internal feedback selection.

Bits 2 to 0: PMux[2:0]. These bits control the multiplexing of the five inputs to the non-inverting input of the opamp.

For additional information, refer to the [ACExxCR1 register on page 192](#).

ACExxCR2 Register

Address	Name	Bit 7	Bit 6	Bit 5	Bit 4	Bit 3	Bit 2	Bit 1	Bit 0	Access
x,73h *	ACE00CR2							FullRange	PWR	RW : 00
x,77h *	ACE01CR2							FullRange	PWR	RW : 00

LEGEND

x An "x" before the comma in the address field indicates that this register can be accessed or written to no matter what bank is used.

* Address has a dual purpose, see "Mapping Exceptions" on page 141.

The Analog Continuous Time Type E Block Control Register 2 (ACExxCR2) is one of two registers used to configure the type E continuous time PSoC block.

Bit 1: FullRange. For slightly higher power, this bit enables inputs from Vss to Vdd.

Bit 0: PWR. This bit is used to power up the CT block and SC block in the column.

For additional information, refer to the [ACExxCR2 register on page 194](#).

24.3.5 Switched Capacitor PSoC Block Register

The naming convention for the switched capacitor register and its array of PSoC blocks is <Prefix>mn<Suffix>, where m=row index and n=column index. Therefore, ASE10CR0 (written ASExxCR0) is a register for an analog PSoC block in row 1 column 0.

ASExxCR0 Register

Add.	Name	Bit 7	Bit 6	Bit 5	Bit 4	Bit 3	Bit 2	Bit 1	Bit 0	Access
x,80h *	ASE10CR0	FVal								RW : 00
x,84h *	ASE11CR0	FVal								RW : 00

LEGEND

x An "x" before the comma in the address field indicates that this register can be accessed or written to no matter what bank is used.

* Address has a dual purpose, see "Mapping Exceptions" on page 141.

The Analog Switch Capacitor Type E Block Control Register 0 (ASExxCR0) is used to configure a type E switched capacitor PSoC block.

For additional information, refer to the [ASExxCR0 register on page 196](#).

Bit 7: FVal. This bit controls the size of the bandwidth of the filler in the Type E block.



Section F: System Resources



The System Resources section discusses the system resources that are available for the PSoC device and the registers associated with those resources. This section contains these chapters:

- [Digital Clocks on page 461](#)
- [Multiply Accumulate \(MAC\) on page 471](#)
- [Decimator on page 477](#)
- [I2C on page 485](#)
- [Internal Voltage Reference on page 503](#)
- [System Resets on page 505](#)
- [Switch Mode Pump \(SMP\) on page 513](#)
- [POR and LVD on page 517](#)
- [IO Analog Multiplexer on page 521](#)
- [Full-Speed USB on page 527](#)
- [nvSRAM on page 539](#)

Top Level System Resources Architecture

The figure below displays the top level architecture of the PSoC's system resources. Each component of the figure is discussed at length in this section. Note that the CY8C22x13 PSoC device does not support the Switch Mode Pump and Multiply Accumulate system resources and the CY8C21xxx PSoC devices do not support the Decimator and Multiply Accumulate system resources. All other PSoC devices support all the system resources found in this section.

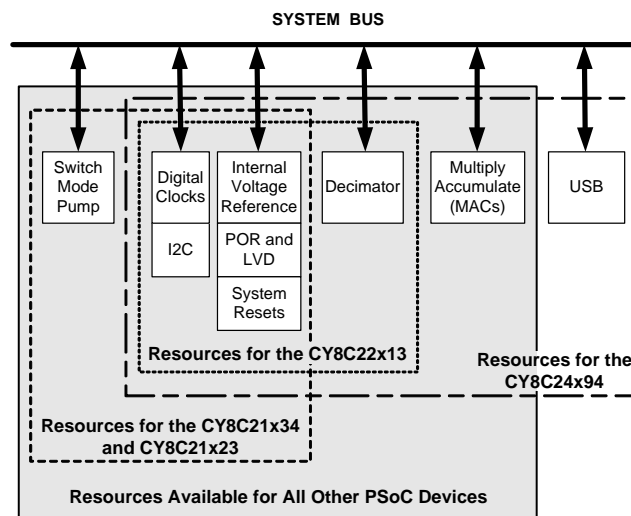

Note The CY8C21x34 is the only PSoC with IO Analog Multiplexer functionality.

PSoC System Resources

Interpreting the System Resources Documentation

Information in this section covers all PSoC devices with a base part number of CY8C2xxxx (except for the CY8C25122 and CY8C26xxx PSoC devices). It also applies to CY7C64215, CY7C603xx, and CYWUSB6953. The following table lists the resources available for specific device groups with a check mark or appropriate information. Blank fields denote that the system resource is not available. Note that the CY8C21x34, CY7C603xx, and CYWUSB6953 are the only PSoC devices that have the IO Analog Multiplexer system resource and that the CY8C24x94 and CY7C64215 are the only PSoC devices that have USB functionality.

PSoC Devices System Resource Availability

PSoC Part Number	USB	Switch Mode Pump	Digital Clocks	I2C	Internal Voltage Ref	POR and LVD	System Resets	Decimator*	Multiply Accumulate	CY8CNP1xx
CY8C29x66 CY8CPLC20 CY8CLED16P01		✓	✓	✓	✓	✓	✓	T2	2	
CY8C27x43		✓	✓	✓	✓	✓	✓	T1	1	
CY8C24x94 **	✓		✓	✓	✓	✓	✓	T2	2	
CY8C24x23		✓	✓	✓	✓	✓	✓	T1	1	
CY8C24x23A		✓	✓	✓	✓	✓	✓	T1	1	
CY8C22x13			✓	✓	✓	✓	✓	T1	0	
CY8C21x34 **		✓	✓	✓	✓	✓	✓		0	
CY8C21x23		✓	✓	✓	✓	✓	✓		0	
CY7C64215 **	✓		✓	✓	✓	✓	✓	T2	2	
CY7C603xx **		✓	✓	✓	✓	✓	✓		0	
CYWUSB6953 **		✓	✓	✓	✓	✓	✓		0	
CY8CNP1xx		✓	✓	✓	✓	✓	✓	T2	2	✓

* Decimator types: T1 = Type 1, T2 = Type 2.

** The PSoC devices that have the IO Analog Multiplexer system resource.

System Resources Register Summary

The table below lists all the PSoC registers for the system resources, in address order, within their system resource configuration. The bits that are grayed out are reserved bits. If these bits are written, they should always be written with a value of '0'.

Note that all PSoC devices have a combination of 4, 2, or 1 analog columns and 4, 2 or 1 digital rows. The registers that are specifically constrained by the number of analog columns have the number of analog columns (Cols.) listed within the Address column of the table. The registers specifically pertaining to digital rows have the number of rows (Rows) listed within the Address column of the table. To determine the number of analog columns and digital rows in your PSoC device, refer to the table titled "PSoC Device Characteristics" on page 373.

Summary Table of the System Resource Registers

Address	Name	Bit 7	Bit 6	Bit 5	Bit 4	Bit 3	Bit 2	Bit 1	Bit 0	Access	
DIGITAL CLOCK REGISTERS (page 465)											
0,DAh	4 Cols.	INT_CLR0	VC3	Sleep	GPIO	Analog 3	Analog 2	Analog 1	Analog 0	V Monitor	RW : 00
	2 Cols.		VC3	Sleep	GPIO			Analog 1	Analog 0	V Monitor	RW : 00
	1 Col.		VC3	Sleep	GPIO			Analog 1		V Monitor	RW : 00
0,E0h	4 Cols.	INT_MSK0	VC3	Sleep	GPIO	Analog 3	Analog 2	Analog 1	Analog 0	V Monitor	RW : 00
	2 Cols.		VC3	Sleep	GPIO			Analog 1	Analog 0	V Monitor	RW : 00
	1 Col.		VC3	Sleep	GPIO			Analog 1		V Monitor	RW : 00
1,DDh	OSC_GO_EN	SLPINT	VC3	VC2	VC1	SYSCCLKX2	SYSCCLK	CLK24M	CLK32K	RW : 00	
1,DEh	OSC_CR4							VC3 Input Select[1:0]			RW : 00
1,DFh	OSC_CR3	VC3 Divider[7:0]									RW : 00
1,E0h	OSC_CR0	32k Select	PLL Mode	No Buzz	Sleep[1:0]		CPU Speed[2:0]			RW : 00	
1,E1h	OSC_CR1	VC1 Divider[3:0]				VC2 Divider[3:0]				RW : 00	
1,E2h	OSC_CR2	PLLGAIN					EXTCLKEN	IMODIS	SYSCCLKX2 DIS	RW : 00	
MULTIPLY ACCUMULATE (MAC) REGISTERS (page 472)											
0,A8h	MUL1_X	Data[7:0]									W : XX
0,A9h	MUL1_Y	Data[7:0]									W : XX
0,AAh	MUL1_DH	Data[7:0]									R : XX
0,ABh	MUL1_DL	Data[7:0]									R : XX
0,ACH	MAC1_X/ ACC1_DR1	Data[7:0]									RW : 00
0,ADh	MAC1_Y/ ACC1_DR0	Data[7:0]									RW : 00
0,AEH	MAC1_CL0/ ACC1_DR3	Data[7:0]									RW : 00
0,AFh	MAC1_CL1/ ACC1_DR2	Data[7:0]									RW : 00
0,E8h	MUL0_X	Data[7:0]									W : XX
0,E9h	MUL0_Y	Data[7:0]									W : XX
0,EAh	MUL0_DH	Data[7:0]									R : XX
0,EBh	MUL0_DL	Data[7:0]									R : XX
0,ECh	MAC0_X/ ACC0_DR1	Data[7:0]									RW : 00
0,EDh	MAC0_Y/ ACC0_DR0	Data[7:0]									RW : 00
0,EEh	MAC0_CL0/ ACC0_DR3	Data[7:0]									RW : 00
0,EFh	MAC0_CL1/ ACC0_DR2	Data[7:0]									RW : 00
DECIMATOR REGISTERS (page 481)											
0,E4h	DEC_DH	Data High Byte[7:0]									RC : XX
0,E5h	DEC_DL	Data Low Byte[7:0]									RC : XX
0,E6h	DEC_CR0	IGEN[3:0]				ICLKS0		DCOL[1:0]		DCLKS0	RW : 00

Summary Table of the System Resource Registers (*continued*)

Address	Name	Bit 7	Bit 6	Bit 5	Bit 4	Bit 3	Bit 2	Bit 1	Bit 0	Access
0,E7h 4 Cols. 2 Cols.	DEC_CR1		IDEC	ICLKS3	ICLKS2	ICLKS1	DCLKS3	DCLKS2	DCLKS1	RW : 00
		ECNT	IDEC	ICLKS3	ICLKS2	ICLKS1	DCLKS3	DCLKS2	DCLKS1	RW : 00
1,E7h 4 Cols.	DEC_CR2 *	Mode[1:0]		Data Out Shift[1:0]		Data Format	Decimation Rate[2:0]			RW : 00
I2C REGISTERS (page 488)										
0,D6h	I2C_CFG		PSelect	Bus Error IE	Stop IE	Clock Rate[1:0]		Enable Master	Enable Slave	RW : 00
0,D7h	I2C_SCR	Bus Error	Lost Arb	Stop Status	ACK	Address	Transmit	LRB	Byte Complete	R : 00
0,D8h	I2C_DR	Data[7:0]								RW : 00
0,D9h	I2C_MSCR					Bus Busy	Master Mode	Restart Gen	Start Gen	R : 00
INTERNAL VOLTAGE REFERENCE REGISTER (page 503)										
1,EAh 4,2 Cols. 1 Col.	BDG_TR		AGNDBYP	TC[1:0]		V[3:0]			RW : 00	
				TC[1:0]		V[3:0]			RW : 00	
SYSTEM RESET REGISTERS (page 507)										
0,FEh	CPU_SCR1	IRESS		SLIMO	ECO EXW	ECO EX		IRAMDIS	# : 00	
0,FFh	CPU_SCR0	GIES		WDRS	PORS	Sleep		STOP	# : XX	
SWITCH MODE PUMP (SMP) REGISTER (page 515)										
1,E3h	VLT_CR	SMP		PORLEV[1:0]		LVDTBEN	VM[2:0]			RW : 00
POR AND LVD REGISTERS (page 517)										
1,E3h 4,2 Cols. 1 Col.	VLT_CR	SMP		PORLEV[1:0]		LVDTBEN	VM[2:0]			RW : 00
				PORLEV[1:0]		LVDTBEN	VM[2:0]			RW : 00
1,E4h 4,2 Cols. 2L** Cols. 1 Col.	VLT_CMP					PUMP	LVD	PPOR	R : 00	
						NoWrite	PUMP	LVD	PPOR	R : 00
							LVD	PPOR	R : 00	
IO ANALOG MULTIPLEXER REGISTERS (page 525)										
0,61h	AMUX_CFG	BCol1Mux	ACol0Mux	INTCAP[1:0]		MUXCLK[2:0]		EN	RW : 00	
0,FDh	DAC_D	DACDATA[7:0]								RW : 00
1,AFh	AMUX_CLK							CLKSYNC[1:0]		RW : 00
1,D8h	MUX_CR0	ENABLE[7:0]								RW : 00
1,D9h	MUX_CR1	ENABLE[7:0]								RW : 00
1,DAh	MUX_CR2	ENABLE[7:0]								RW : 00
1,DBh	MUX_CR3	ENABLE[7:0]								RW : 00
1,ECh	MUX_CR4	ENABLE[7:0]								RW : 00
1,EDh	MUX_CR5	ENABLE[7:0]								RW : 00
1,FDh	DAC_CR	SplitMux	MuxClkGE			IRANGE	OSCMODE[1:0]	ENABLE	RW : 00	

Summary Table of the System Resource Registers (continued)

Address	Name	Bit 7	Bit 6	Bit 5	Bit 4	Bit 3	Bit 2	Bit 1	Bit 0	Access	
FULL-SPEED USB REGISTERS (page 533)											
0,40h	PMA0_DR	Data[7:0]								RW : 00	
0,41h	PMA1_DR	Data[7:0]								RW : 00	
0,42h	PMA2_DR	Data[7:0]								RW : 00	
0,43h	PMA3_DR	Data[7:0]								RW : 00	
0,44h	PMA4_DR	Data[7:0]								RW : 00	
0,45h	PMA5_DR	Data[7:0]								RW : 00	
0,46h	PMA6_DR	Data[7:0]								RW : 00	
0,47h	PMA7_DR	Data[7:0]								RW : 00	
0,48h	USB_SOF0	Frame Number[7:0]								R : 00	
0,49h	USB_SOF1						Frame Number[10:8]				R : 00
0,4Ah	USB_CR0	USB Enable	Device Address[6:0]								RW : 00
0,4Bh	USBIO_CR0	TEN	TSE0	TD					RD	# : 00	
0,4Ch	USBIO_CR1	IOMode	Drive Mode	DPI	DMI	PS2PUEN	USBPUEEN	DPO	DMO	RW : XX	
0,4Eh	EP1_CNT1	Data Toggle	Data Valid				Byte Count[3:0]			# : 00	
0,4Fh	EP1_CNT	EP1 Count[7:0]								RW : 00	
0,50h	EP2_CNT1	Data Toggle	Data Valid				Byte Count[3:0]			# : 00	
0,51h	EP2_CNT	EP2 Count[7:0]								RW : 00	
0,52h	EP3_CNT1	Data Toggle	Data Valid				Byte Count[3:0]			# : 00	
0,53h	EP3_CNT	EP3 Count[7:0]								RW : 00	
0,54h	EP4_CNT1	Data Toggle	Data Valid				Byte Count[3:0]			# : 00	
0,55h	EP4_CNT	EP4 Count[7:0]								RW : 00	
0,56h	EP0_CR	Setup Received	IN Received	OUT Received	ACK'd Transaction	Mode[3:0]				# : 00	
0,57h	EP0_CNT	Data Toggle	Data Valid				Byte Count[3:0]			# : 00	
0,58h	EP0_DR0	Data Byte[7:0]								RW : 00	
0,59h	EP0_DR1	Data Byte[7:0]								RW : 00	
0,5Ah	EP0_DR2	Data Byte[7:0]								RW : 00	
0,5Bh	EP0_DR3	Data Byte[7:0]								RW : 00	
0,5Ch	EP0_DR4	Data Byte[7:0]								RW : 00	
0,5Dh	EP0_DR5	Data Byte[7:0]								RW : 00	
0,5Eh	EP0_DR6	Data Byte[7:0]								RW : 00	
0,5Fh	EP0_DR7	Data Byte[7:0]								RW : 00	
1,40h	PMA0_WA	Address[7:0]								RW : 00	
1,41h	PMA1_WA	Address[7:0]								RW : 00	
1,42h	PMA2_WA	Address[7:0]								RW : 00	
1,43h	PMA3_WA	Address[7:0]								RW : 00	
1,44h	PMA4_WA	Address[7:0]								RW : 00	
1,45h	PMA5_WA	Address[7:0]								RW : 00	
1,46h	PMA6_WA	Address[7:0]								RW : 00	
1,47h	PMA7_WA	Address[7:0]								RW : 00	
1,50h	PMA0_RA	Address[7:0]								RW : 00	
1,51h	PMA1_RA	Address[7:0]								RW : 00	
1,52h	PMA2_RA	Address[7:0]								RW : 00	
1,53h	PMA3_RA	Address[7:0]								RW : 00	
1,54h	PMA4_RA	Address[7:0]								RW : 00	
1,55h	PMA5_RA	Address[7:0]								RW : 00	
1,56h	PMA6_RA	Address[7:0]								RW : 00	
1,57h	PMA7_RA	Address[7:0]								RW : 00	
1,C1h	USB_CR1						Bus Activity	EnableLock	RegEnable	RW : 00	

Summary Table of the System Resource Registers (*continued*)

Address	Name	Bit 7	Bit 6	Bit 5	Bit 4	Bit 3	Bit 2	Bit 1	Bit 0	Access
1,C4h	EP1_CR0	Stall		NAK Int Enable	ACK'd Transaction	Mode[3:0]			# : 00	
1,C5h	EP2_CR0	Stall		NAK Int Enable	ACK'd Transaction	Mode[3:0]			# : 00	
1,C6h	EP3_CR0	Stall		NAK Int Enable	ACK'd Transaction	Mode[3:0]			# : 00	
1,C7h	EP4_CR0	Stall		NAK Int Enable	ACK'd Transaction	Mode[3:0]			# : 00	
1,EEh	IMO_TR1						Fine Trim[2:0]			RW : 00
1,EFh	IMO_TR2						Gain Trim[5:0]			RW : 30

LEGEND

X The value after power on reset is unknown.

* This register is only for used with the CY8C29x66 and CY8CNP1xx PSoC devices.

C Clearable register or bits.

R Read register or bit(s).

W Write register or bit(s).

Access is bit specific. Refer to the [Register Details chapter on page 147](#) for additional information.

** The 2L column row is only applicable to the CY8C21x34, CY8C21x23, CY7C603xx, and CYWUSB6953 PSoC devices which have two column limited analog functionality.

25. Digital Clocks



This chapter discusses the Digital Clocks and their associated registers. It serves as an overview of the clocking options available in the PSoC devices. For detailed information on specific oscillators, see the individual oscillator chapters in the section called “PSoC Core” on page 59. For a complete table of the digital clock registers, refer to the “Summary Table of the System Resource Registers” on page 455. For a quick reference of all PSoC registers in address order, refer to the Register Details chapter on page 147.

25.1 Architectural Description

The PSoC M8C core has a large number of clock sources that increase the flexibility of the PSoC programmable system-on-chip, as listed in Table 25-1 and illustrated in Figure 25-1.

Table 25-1. System Clocking Signals and Definitions

Signal	Definition
SYCLKX2	Twice the frequency of SYCLK.
SYCLK	Either the direct output of the Internal Main Oscillator or the direct input of the EXTCLK pin while in external clocking mode.
CPUCLK	SYCLK is divided down to one of eight possible frequencies, to create CPUCLK which determines the speed of the M8C. See OSC_CR0 in the Register Definitions section of this chapter.
VC1	SYCLK is divided down to create Variable Clock 1 (VC1). See OSC_CR1 in the Register Definitions section of this chapter. Division range is from 1 to 16.
VC2	VC1 is divided down to create Variable Clock 2 (VC2). See OSC_CR1 in the Register Definitions section of this chapter. Division range is from 1 to 16.
VC3	Divides down either SYCLK, VC1, VC2, or SYCLKX2 to create Variable Clock 3 (VC3). Division range is from 1 to 256. See OSC_CR3 and OSC_CR4 in the Register Definitions section of this chapter.
CLK32K	Either the Internal Low Speed Oscillators or the External Crystal Oscillators output. See OSC_CR0 in the Register Definitions section of this chapter.
CLK24M	The internally generated 24 MHz clock by the IMO. By default, this clock drives SYCLK; however, an external clock may be used by enabling EXTCLK mode. Also, the IMO may be put into a slow mode using the SLIMO bit which will change the speed of the IMO and the CLK24M to either 6 MHz or 12 MHz in some PSoC devices.
SLEEP	One of four sleep intervals may be selected from 1.95 ms to 1 second. See OSC_CR0 in the Register Definitions section of this chapter.

25.1.1 Internal Main Oscillator

The Internal Main Oscillator (IMO) is the foundation upon which almost all other clock sources in the PSoC programmable system-on-chip are based. The default mode of the IMO creates a 24 MHz reference clock that is used by many other circuits in the PSoC device. The IMO may also be configured to operate in a PLL mode where the oscillator is locked to a precision 32.768 kHz crystal reference. The PSoC device has an option to replace the IMO with an externally supplied clock that will become the base for all of the clocks the IMO normally serves. The internal base clock net is called SYCLK and may be driven by either the IMO or an external clock (EXTCLK).

Whether the external clock or the internal main oscillator is selected, all PSoC device functions are clocked from a derivative of SYCLK or are resynchronized to SYCLK. All external asynchronous signals (through row inputs), as well as the selected 32.768 kHz crystal oscillator, are resynchronized to SYCLK for use in the digital PSoC blocks.

Some PSoC devices contain the option to lower the internal oscillator’s system clock from 24 MHz to 6 MHz. See the “Architectural Description” on page 113, in the Internal Main Oscillator chapter, for more information.

The IMO is discussed in detail in the chapter “Internal Main Oscillator (IMO)” on page 113.

25.1.2 Internal Low Speed Oscillator

The Internal Low Speed Oscillator (ILO) is always on unless the device is operating off an external crystal. The ILO is available as a general clock, but is also the clock source for the sleep and watchdog timers.

The ILO is discussed in detail in the chapter “Internal Low Speed Oscillator (ILO)” on page 117.

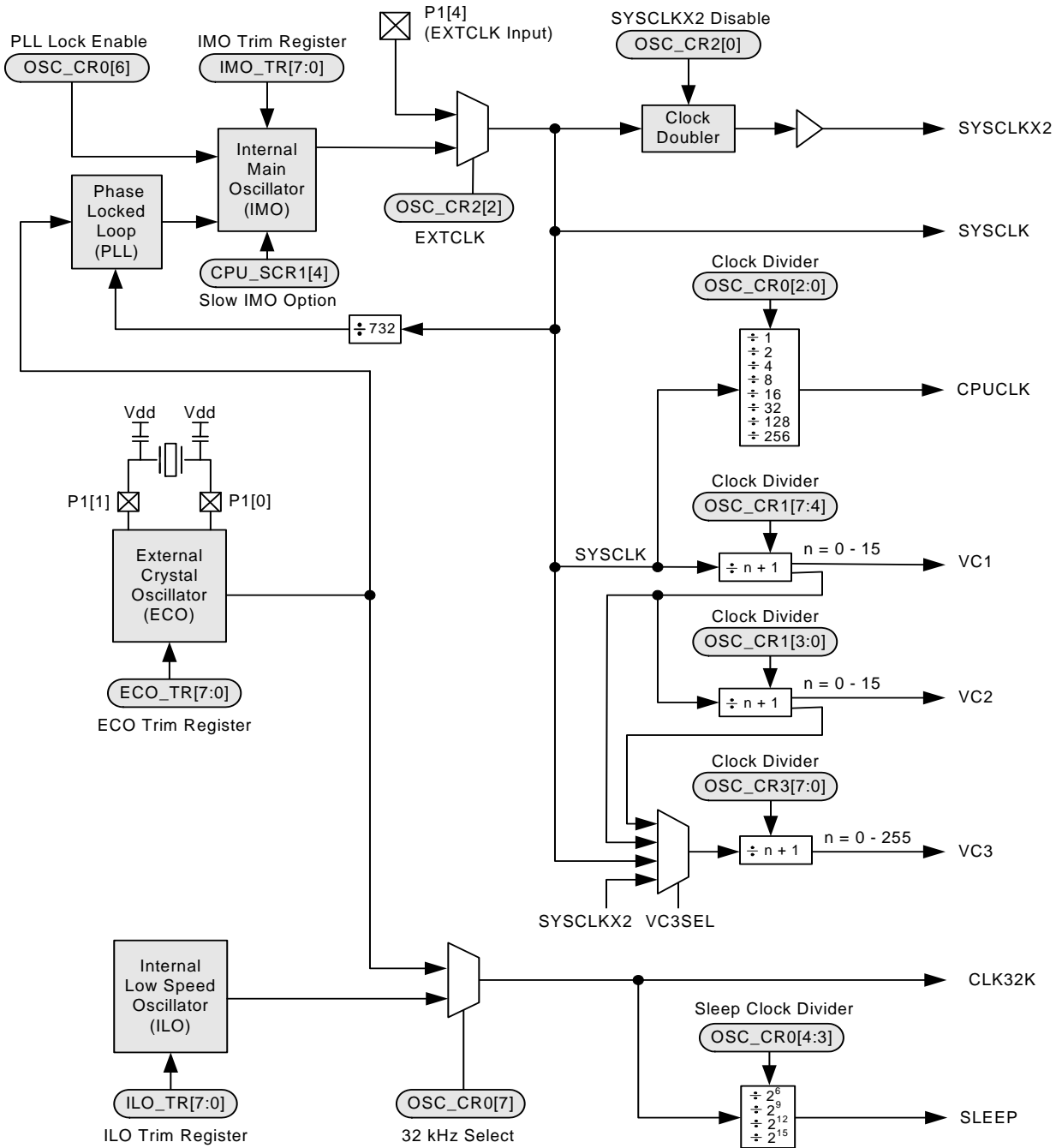

Figure 25-1. Overview of PSoC Clock Sources

25.1.3 32.768 kHz Crystal Oscillator

The PSoC may be configured to use an external crystal. The crystal oscillator is discussed in detail in the chapter “External Crystal Oscillator (ECO)” on page 119.

25.1.4 External Clock

The ability to replace the 24 MHz internal main oscillator (IMO), as the device master system clock (SYSCLK) with an externally supplied clock, is a feature in the PSoC programmable system-on-chip (see Figure 25-1).

Pin P1[4] is the input pin for the external clock. This pin was chosen because it is not associated with any special features such as analog IO, crystal, or In System Serial Programming (ISSP). It is also not physically close to either the P1[0] and P1[1] crystal pins. If P1[4] is selected as the external clock source, the drive mode of the pin must be set to High Z (not High Z analog).

The user is able to supply an external clock with a frequency between 1 MHz and 24 MHz. The reset state of the EXTCLKEN bit is ‘0’; and therefore, the device always boots up under the control of the IMO. There is no way to start the system from a reset state with the external clock.

When the EXTCLKEN bit is set, the external clock becomes the source for the internal clock tree, SYSCLK, which drives most PSoC device clocking functions. All external and internal signals, including the 32 kHz clock, whether derived from the internal low speed oscillator (ILO) or the crystal oscillator, are synchronized to this clock source.

25.1.4.1 Clock Doubler

One of the blocks driven by the system clock is the clock doubler circuit that drives the SYSCLKX2 output. This doubled clock, which is 48 MHz when the IMO is the selected clock (at 24 MHz), may be used as a clock source for the digital PSoC blocks. When the external clock is selected, the SYSCLKX2 signal is still available and serves as a doubler for whatever frequency is input on the external clock pin.

Following the specification for the external clock input ensures that the internal circuitry of the digital PSoC blocks, which is clocked by SYSCLKX2, will meet timing requirements. However, since the doubled clock is generated from both edges of the input clock, clock jitter is introduced if the duty cycle deviates greatly from 50 percent. Also, the high time of the clock out of the doubler is fixed at 21 ns, so the duty cycle of SYSCLKX2 is proportional to the inverse of the frequency, as shown in Figure 25-2. Regardless of the input frequency, the high period of SYSCLKX2 is 21 ns nominal.

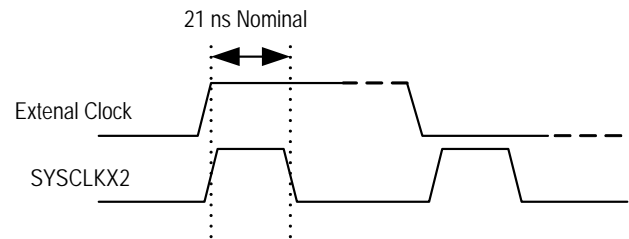

Figure 25-2. Operation of the Clock Doubler

25.1.4.2 Switch Operation

Switching between the IMO and the external clock may be done in firmware at any time and is transparent to the user. Since all PSoC device resources run on clocks derived from or synchronized to SYSCLK, when the switch is made, analog and digital functions may be momentarily interrupted.

When a switch is made from the IMO to the external clock, the IMO may be turned off to save power. This is done by setting the IMODIS bit and may be done immediately after the instruction that sets the EXTCLKEN bit. However, when switching back from an external clock to the IMO, the IMODIS bit must be cleared and a firmware delay implemented. This gives the IMO sufficient start-up time before the EXTCLKEN bit is cleared.

Switch timing depends on whether the CPU clock divider is set for divide by 1, or divide by 2 or greater. In the case where the CPU clock divider is set for divide by 2 or greater, as shown in Figure 25-3, the setting of the EXTCLKEN bit occurs shortly after the rising edge of SYSCLK. The SYSCLK output is then disabled after the next falling edge of SYSCLK, but before the next rising edge. This ensures a glitch-free transition and provides a full cycle of setup time from SYSCLK to output disable. Once the current clock selection is disabled, the enable of the newly selected clock is double synchronized to that clock. After synchronization, on the subsequent negative edge, SYSCLK is enabled to output the newly selected clock.

In the 24 MHz case, as shown in Figure 25-4, the assertion of IOW_ and thus the setting of the EXTCLKEN bit occurs on the falling edge of SYSCLK. Since SYSCLK is already low, the output is immediately disabled. Therefore, the setup time from SYSCLK to disable is one-half SYSCLK.

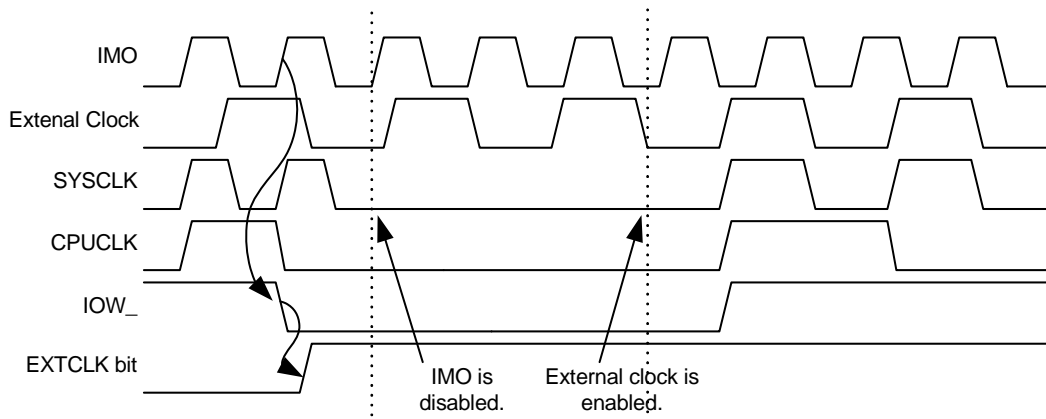

Figure 25-3. Switch from IMO to the External Clock with a CPU Clock Divider of Two or Greater

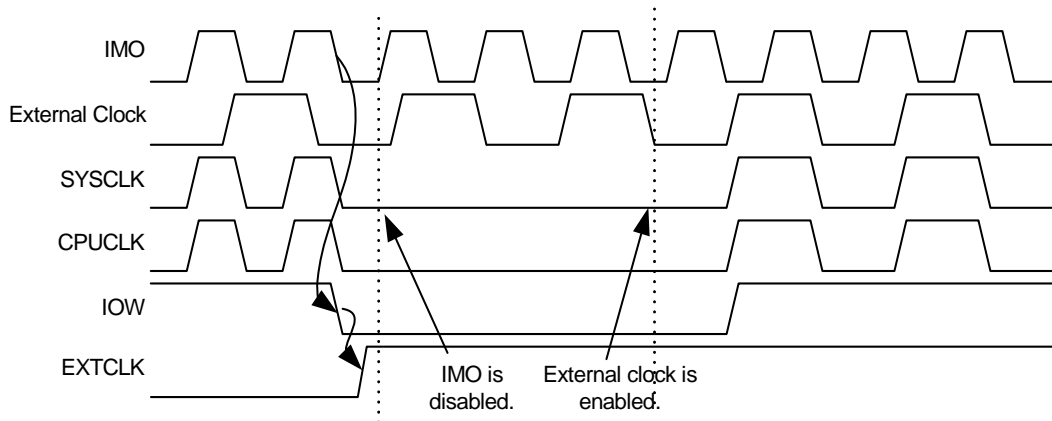

Figure 25-4. Switch from IMO to External Clock with the CPU Running with a CPU Clock Divider of One

25.2 PSoC Device Distinctions

The PSoC device distinctions that apply to the digital clocks are listed as follows.

- In PSoC devices with a part number of CY8C27x43, bits 7, 6, 5, and 4 of the OSC_GO_EN register are reserved. See the [OSC_GO_EN register on page 288](#) for more information.
- In PSoC devices with a part number of CY8C24x23 or CY8C22x13, bit 7 of the OSC_GO_EN register is reserved. However, in PSoC devices with a part number of CY8C24x23A, bit 7 is not reserved.
- For Silicon Revision A of the CY8C27x43 PSoC device, only digital blocks DCB01, DCB02, DCB01, and DCB12 are valid in the DEC_CR1 register. See the [DEC_CR1 register on page 247](#) for more information.

25.3 Register Definitions

The following registers are associated with the Digital Clocks and are listed in address order. Each register description has an associated register table showing the bit structure for that register. For a complete table of digital clock registers, refer to the “Summary Table of the System Resource Registers” on page 455.

Depending on your PSoC device's configuration (refer to the table titled “PSoC Device Characteristics” on page 371), only certain bits are accessible to be read or written, such as the INT_CLR0 and INT_MSK0 registers that are analog column dependent (see the “Cols.” column in the tables below). The bits in the tables that are grayed out throughout this manual are reserved bits and are not detailed in the register descriptions that follow. Reserved bits should always be written with a value of '0'.

25.3.1 INT_CLR0 Register

Addr.	Name	Cols.	Bit 7	Bit 6	Bit 5	Bit 4	Bit 3	Bit 2	Bit 1	Bit 0	Access
0,DAh	INT_CLR0	4, 3	VC3	Sleep	GPIO	Analog 3	Analog 2	Analog 1	Analog 0	V Monitor	RW : 00
		2	VC3	Sleep	GPIO			Analog 1	Analog 0	V Monitor	RW : 00
		1	VC3	Sleep	GPIO			Analog 1		V Monitor	RW : 00

The Interrupt Clear Register 0 (INT_CLR0) is used to enable the individual interrupt sources' ability to clear posted interrupts.

Bit 7: VC3. The digital clocks only use bit 7 of the INT_CLR0 register for the VC3 clock. This bit controls the VC3 clock interrupt status.

Bits 6 to 0. The INT_CLR0 register holds bits that are used by several different resources. For a full discussion of the INT_CLR0 register, see the [INT_CLRx Registers](#) in the [Interrupt Controller](#) chapter on page 95.

For additional information, refer to the [INT_CLR0 register](#) on page 229.

25.3.2 INT_MSK0 Register

Addr.	Name	Cols.	Bit 7	Bit 6	Bit 5	Bit 4	Bit 3	Bit 2	Bit 1	Bit 0	Access
0,E0h	INT_MSK0	4, 3	VC3	Sleep	GPIO	Analog 3	Analog 2	Analog 1	Analog 0	V Monitor	RW : 00
		2	VC3	Sleep	GPIO			Analog 1	Analog 0	V Monitor	RW : 00
		1	VC3	Sleep	GPIO			Analog 1		V Monitor	RW : 00

The Interrupt Mask Register 0 (INT_MSK0) is used to enable the individual sources' ability to create pending interrupts.

Bit 7: VC3. The digital clocks only use bit 7 of the INT_MSK0 register for the VC3 clock. This bit controls the VC3 clock interrupt enable.

Bits 6 to 0. The INT_MSK0 register holds bits that are used by several different resources. For a full discussion of the INT_MSK0 register, see the [INT_MSKx Registers](#) in the [Interrupt Controller](#) chapter on page 95.

For additional information, refer to the [INT_MSK0 register](#) on page 239.

25.3.3 OSC_GO_EN Register

Address	Name	Bit 7	Bit 6	Bit 5	Bit 4	Bit 3	Bit 2	Bit 1	Bit 0	Access
1,DDh	OSC_GO_EN	SLPINT	VC3	VC2	VC1	SYCLKX2	SYCLK	CLK24M	CLK32K	RW : 00

The Oscillator to Global Outputs Enable Register (OSC_GO_EN) is used to enable tri-state buffers that connect specific system clocks to specific global output even nets.

The OSC_GO_EN register holds eight bits which independently enable a tri-state buffer to drive a clock on to a global net. In all cases, the clock is driven on to one of the nets in the Global Output Even (GOE) bus. In all cases, these bits should only be set and the resulting clock signal on the global be used when the clock frequency is less than or equal to the maximum **switching** frequency of the global buses (12 MHz). Therefore, bits 2 and 3 are only useful when the PSoC device is in external clocking mode and bit 1 may never be used.

Note See “PSoC Device Distinctions” on page 462 for more information about this register.

Bit 7: SLPINT. This bit provides the option to connect the sleep interrupt signal to GOE[7]. This may be useful in real-time clock applications where very low power is required. By driving the sleep interrupt to a global, it may then be routed to a digital PSoC block. The digital PSoC block may then count several sleep interrupts before generating its own

interrupt, which would be used to bring the PSoC device out of the sleep state.

Bit 6: VC3. This bit enables the driving of the VC3 clock onto GOE[6].

Bit 5: VC2. This bit enables the driving of the VC2 clock onto GOE[5].

Bit 4: VC1. This bit enables the driving of the VC1 clock onto GOE[4].

Bit 3: SYCLKX2. This bit enables the driving of the SYCLKX2 clock onto GOE[3].

Bit 2: SYCLK. This bit enables the driving of the SYCLK clock onto GOE[2].

Bit 1: CLK24M. This bit enables the driving of the 24 Mhz clock onto GOE[1].

Bit 0: CLK32K. This bit enables the driving of the 32 kHz clock onto GOE[0].

For additional information, refer to the OSC_GO_EN register on page 288.

25.3.4 OSC_CR4 Register

Address	Name	Bit 7	Bit 6	Bit 5	Bit 4	Bit 3	Bit 2	Bit 1	Bit 0	Access
1,DEh	OSC_CR4								VC3 Input Select[1:0]	RW : 00

The Oscillator Control Register 4 (OSC_CR4) selects the input clock to variable clock 3 (VC3).

Bits 1 and 0: VC3 Input Select [1:0]. The VC3 clock net is the only clock net with the ability to generate an interrupt. The input clock of VC3 comes from a configurable source. As shown in Figure 25-1 on page 460, a 4-to-1 mux determines the clock that is used in the input to the VC3 divider. The mux allows either the 48 MHz, 24 MHz, VC1, or VC2 clocks to be used as the input clock to the divider. Because the selection of a clock for the VC3 divider is performed by a simple 4-to-1 mux, **runt pulses** and glitches may be injected to the VC3 divider when the OSC_CR4[1:0] bits are changed. Care should be taken to ensure that blocks using the VC3 clock are either disabled when OSC_CR4[1:0] is changed or not sensitive to glitches. Unlike the VC1 and VC2 clock dividers, the VC3 clock divider is 8-bits wide. Therefore, there are 256 valid divider values as indicated by Table 25-3.

It is important to remember that even though the VC3 divider has four choices for the input clock, none of the choices have fixed frequencies for all device configurations. Both the 24 MHz and 48 MHz clocks may have very different frequencies if an external clock is in use. Also, the divider values for the VC1 and VC2 inputs to the mux must be considered.

Table 25-2. OSC_CR4[1:0] Bits: VC3

Bits	Multiplexer Output
00b	SYCLK
01b	VC1
10b	VC2
11b	SYCLKX2

For additional information, refer to the OSC_CR4 register on page 289.

25.3.5 OSC_CR3 Register

Address	Name	Bit 7	Bit 6	Bit 5	Bit 4	Bit 3	Bit 2	Bit 1	Bit 0	Access
1,DFh	OSC_CR3	VC3 Divider[7:0]								RW : 00

The Oscillator Control Register 3 (OSC_CR3) selects the divider value for variable clock 3 (VC3).

Bits 7 to 0: VC3 Divider[7:0]. As an example of the flexibility of the clocking structure in PSoC devices, consider a device that is running off of an externally supplied clock at a frequency of 93.7 kHz. This clock value may be divided by the VC1 divider to achieve a VC1 clock net frequency of 5.89 kHz. The VC2 divider could reduce the frequency by another factor of 16, resulting in a VC2 clock net frequency of 366.02 Hz. Finally, the VC3 divider may choose VC2 as its input clock and divide by 256, resulting in a VC3 clock net frequency of 1.43 Hz.

Table 25-3. OSC_CR3[7:0] Bits: VC3 Divider Value

Bits	Divider Source Clock			
	SYCLKX2	SYCLK	VC1	VC2
00h	SYCLKX2	SYCLK	VC1	VC2
01h	SYCLKX2 / 2	SYCLK / 2	VC1 / 2	VC2 / 2
02h	SYCLKX2 / 3	SYCLK / 3	VC1 / 3	VC2 / 3
03h	SYCLKX2 / 4	SYCLK / 4	VC1 / 4	VC2 / 4
...
FCh	SYCLKX2 / 253	SYCLK / 253	VC1 / 253	VC2 / 253
FDh	SYCLKX2 / 254	SYCLK / 254	VC1 / 254	VC2 / 254
FEh	SYCLKX2 / 255	SYCLK / 255	VC1 / 255	VC2 / 255
FFh	SYCLKX2 / 256	SYCLK / 256	VC1 / 256	VC2 / 256

The VC3 clock net can generate a system interrupt. Once the input clock and the divider value for the VC3 clock are chosen, only one additional step is needed to enable the interrupt; the VC3 mask bit must be set in register INT_MSK0[7]. Once the VC3 mask bit is set, the VC3 clock generates pending interrupts every number of clock periods equal to the VC3 divider register value plus one. Therefore, if the VC3 divider register's value is 05h (divide by 6), an interrupt would occur every six periods of the VC3's input clock. Another example would be if the divider value was 00h (divide by one), an interrupt would be generated on every period of the VC3 clock. The VC3 mask bit only controls the ability of a posted interrupt to become pending. Because there is no enable for the VC3 interrupt, VC3 interrupts will always be posting. See the [Interrupt Controller chapter on page 95](#) for more information on posting and pending.

For additional information, refer to the [OSC_CR3 register on page 290](#).

25.3.6 OSC_CR0 Register

Address	Name	Bit 7	Bit 6	Bit 5	Bit 4	Bit 3	Bit 2	Bit 1	Bit 0	Access
1,E0h	OSC_CR0	32k Select	PLL Mode	No Buzz	Sleep[1:0]		CPU Speed[2:0]			RW : 00

The Oscillator Control Register 0 (OSC_CR0) is used to configure various features of internal clock sources and clock nets.

Note Bits 7 and 6 cannot be used by the CY8C21xxx, CY8C24x94, and CY7C64215 PSoC devices.

Bit 7: 32k Select. By default, the 32 kHz clock source is the Internal Low-Speed Oscillator (ILO). Optionally, the 32.768 kHz External Crystal Oscillator (ECO) may be selected.

Bit 6: PLL Mode. This bit is the only bit that directly influences the PLL. When set, it enables the PLL. The EXTCLK bit should be set low during PLL operation.

Bit 5: No Buzz. Normally, when the Sleep bit is set in the CPU_SCR register, all PSoC device systems are powered down, including the bandgap reference. However, to facilitate the detection of POR and LVD events at a rate higher than the sleep interval, the bandgap circuit is powered up periodically (for about 60 μs) at the Sleep System Duty Cycle (set in ECO_TR), which is independent of the sleep interval and typically higher. When the No Buzz bit is set, the Sleep System Duty Cycle value is overridden and the bandgap circuit is forced to be on during sleep. This results in faster response to an LVD or POR event (continuous detection as opposed to periodic), at the expense of slightly higher average sleep current.

Bits 4 and 3: Sleep[1:0]. The available sleep interval selections are shown in [Table 25-4](#). Remember that when the ILO is the selected 32 kHz clock source, sleep intervals are approximate.

Table 25-4. Sleep Interval Selections

Sleep Interval OSC_CR[4:3]	Sleep Timer Clocks	Sleep Period (nominal)	Watchdog Period (nominal)
00b (default)	64	1.95 ms	6 ms
01b	512	15.6 ms	47 ms
10b	4096	125 ms	375 ms
11b	32,768	1 sec	3 sec

Bits 2 to 0: CPU Speed[2:0]. The PSoC M8C may operate over a range of CPU clock speeds ([Table 25-5](#)), allowing the M8C's performance and power requirements to be tailored to the application.

The reset value for the CPU speed bits is zero. Therefore, the default CPU speed is one-eighth of the clock source. The internal main oscillator is the default clock source for the CPU speed circuit; therefore, the default CPU speed is 3

MHz. See [“External Clock” on page 461](#) for more information on the supported frequencies for externally supplied clocks.

The CPU frequency is changed with a write to the OSC_CR0 register. There are eight frequencies generated from a power-of-two divide circuit, which are selected by a 3-bit code. At any given time, the CPU 8-to-1 clock mux is selecting one of the available frequencies, which is resynchronized to the 24 MHz master clock at the output.

Regardless of the CPU speed bit's setting, if the actual CPU speed is greater than 12 MHz, the 24 MHz operating requirements apply. An example of this scenario is a device that is configured to use an external clock, which is supplying a frequency of 20 MHz. If the CPU speed register's value is 0x03, the CPU clock is 20 MHz. Therefore, the supply voltage requirements for the device are the same as if the part was operating at 24 MHz off of the internal main oscillator. The operating voltage requirements are not relaxed until the CPU speed is at 12.0 MHz or less.

Some devices support the slow IMO option, as discussed in the IMO chapter in the [“Architectural Description” on page 113](#). This offers an option to lower both system and CPU clock speed in order to save power.

Table 25-5. OSC_CR0[2:0] Bits: CPU Speed

Bits	6 MHz Internal Main Oscillator *	24 MHz Internal Main Oscillator	External Clock
000b	750 kHz	3 MHz	EXTCLK/ 8
001b	1.5 MHz	6 MHz	EXTCLK/ 4
010b	3 MHz	12 MHz	EXTCLK/ 2
011b **	6 MHz	24 MHz	EXTCLK/ 1
100b	375 kHz	1.5 MHz	EXTCLK/ 16
101b	187.5 kHz	750 kHz	EXTCLK/ 32
110b	93.7 kHz	187.5 kHz	EXTCLK/ 128
111b	23.4 kHz	93.7 kHz	EXTCLK/ 256

* For PSoC devices that support the slow IMO option, see the [“Architectural Description” on page 113](#).

** Selection 011b (24MHz) is not available for CY7C603xx due to lower operating voltage.

An automatic protection mechanism is available for systems that need to run at peak CPU clock speed but cannot guarantee a high enough supply voltage for that clock speed. See the LVDTBEN bit in the [“VLT_CR Register” on page 514](#) for more information.

For additional information, refer to the [OSC_CR0 register on page 291](#).

25.3.7 OSC_CR1 Register

Address	Name	Bit 7	Bit 6	Bit 5	Bit 4	Bit 3	Bit 2	Bit 1	Bit 0	Access
1,E1h	OSC_CR1	VC1 Divider[3:0]				VC2 Divider[3:0]				RW : 00

The Oscillator Control Register 1 (OSC_CR1) selects the divider value for variable clocks 1 and 2 (VC1 and VC2).

Bits 7 to 4: VC1 Divider[3:0]. The VC1 clock net is one of the variable clock nets available in the PSoC M8C. The source for the VC1 clock net is a simple 4-bit divider. The source for the divider is the 24 MHz system clock; however, if the device is configured to use an external clock, the input to the divider is the external clock. Therefore, the VC1 clock net is not always the result of dividing down a 24 MHz clock. The 4-bit divider that controls the VC1 clock net may be configured to divide, using any integer value between 1 and 16. Table 25-6 lists all values for the VC1 clock net.

Bits 3 to 0: VC2 Divider[3:0]. The VC2 clock net is one of the variable clock nets available in the PSoC M8C. The source for the VC2 clock net is a simple 4-bit divider. The source for the divider is the VC1 clock net. The 4-bit divider that controls the VC2 clock net may be configured to divide, using any integer value between 1 and 16. Table 25-7 lists all values for the VC2 clock net.

Table 25-6. OSC_CR1[7:4] Bits: VC1 Divider Value

Bits	Divider Source Clock	
	Internal Main Oscillator at 24 MHz	External Clock
0h	24 MHz	EXTCLK / 1
1h	12 MHz	EXTCLK / 2
2h	8 MHz	EXTCLK / 3
3h	6 MHz	EXTCLK / 4
4h	4.8 MHz	EXTCLK / 5
5h	4 MHz	EXTCLK / 6
6h	3.43 MHz	EXTCLK / 7
7h	3 MHz	EXTCLK / 8
8h	2.67 MHz	EXTCLK / 9
9h	2.40 MHz	EXTCLK / 10
Ah	2.18 MHz	EXTCLK / 11
Bh	2.00 MHz	EXTCLK / 12
Ch	1.85 MHz	EXTCLK / 13
Dh	1.71 MHz	EXTCLK / 14
Eh	1.6 MHz	EXTCLK / 15
Fh	1.5 MHz	EXTCLK / 16

Table 25-7. OSC_CR1[3:0] Bits: VC2 Divider Value

Bits	Divider Source Clock	
	Internal Main Oscillator	External Clock
0h	$(24 / (\text{OSC_CR1}[7:4]+1)) / 1$	$(\text{EXTCLK} / (\text{OSC_CR1}[7:4]+1)) / 1$
1h	$(24 / (\text{OSC_CR1}[7:4]+1)) / 2$	$(\text{EXTCLK} / (\text{OSC_CR1}[7:4]+1)) / 2$
2h	$(24 / (\text{OSC_CR1}[7:4]+1)) / 3$	$(\text{EXTCLK} / (\text{OSC_CR1}[7:4]+1)) / 3$
3h	$(24 / (\text{OSC_CR1}[7:4]+1)) / 4$	$(\text{EXTCLK} / (\text{OSC_CR1}[7:4]+1)) / 4$
4h	$(24 / (\text{OSC_CR1}[7:4]+1)) / 5$	$(\text{EXTCLK} / (\text{OSC_CR1}[7:4]+1)) / 5$
5h	$(24 / (\text{OSC_CR1}[7:4]+1)) / 6$	$(\text{EXTCLK} / (\text{OSC_CR1}[7:4]+1)) / 6$
6h	$(24 / (\text{OSC_CR1}[7:4]+1)) / 7$	$(\text{EXTCLK} / (\text{OSC_CR1}[7:4]+1)) / 7$
7h	$(24 / (\text{OSC_CR1}[7:4]+1)) / 8$	$(\text{EXTCLK} / (\text{OSC_CR1}[7:4]+1)) / 8$
8h	$(24 / (\text{OSC_CR1}[7:4]+1)) / 9$	$(\text{EXTCLK} / (\text{OSC_CR1}[7:4]+1)) / 9$
9h	$(24 / (\text{OSC_CR1}[7:4]+1)) / 10$	$(\text{EXTCLK} / (\text{OSC_CR1}[7:4]+1)) / 10$
Ah	$(24 / (\text{OSC_CR1}[7:4]+1)) / 11$	$(\text{EXTCLK} / (\text{OSC_CR1}[7:4]+1)) / 11$
Bh	$(24 / (\text{OSC_CR1}[7:4]+1)) / 12$	$(\text{EXTCLK} / (\text{OSC_CR1}[7:4]+1)) / 12$
Ch	$(24 / (\text{OSC_CR1}[7:4]+1)) / 13$	$(\text{EXTCLK} / (\text{OSC_CR1}[7:4]+1)) / 13$
Dh	$(24 / (\text{OSC_CR1}[7:4]+1)) / 14$	$(\text{EXTCLK} / (\text{OSC_CR1}[7:4]+1)) / 14$
Eh	$(24 / (\text{OSC_CR1}[7:4]+1)) / 15$	$(\text{EXTCLK} / (\text{OSC_CR1}[7:4]+1)) / 15$
Fh	$(24 / (\text{OSC_CR1}[7:4]+1)) / 16$	$(\text{EXTCLK} / (\text{OSC_CR1}[7:4]+1)) / 16$

For additional information, refer to the OSC_CR1 register on page 292.

25.3.8 OSC_CR2 Register

Address	Name	Bit 7	Bit 6	Bit 5	Bit 4	Bit 3	Bit 2	Bit 1	Bit 0	Access
1,E2h	OSC_CR2	PLLGAIN					EXTCLKEN	IMODIS	SYSCCLKX2DIS	RW : 00

The Oscillator Control Register 2 (OSC_CR2) is used to configure various features of internal clock sources and clock nets.

Bit 7: PLLGAIN. This is the only bit in the OSC_CR2 register that directly influences the PLL. When set, this bit keeps the PLL in a Low Gain mode. If this bit is held low, the lock time is less than 10 ms. If this bit is held high, the lock time is on the order of 50 ms. After lock is achieved, it is recommended that this bit be forced high to decrease the jitter on the output. If longer lock time is tolerable, the PLLGAIN bit can be held high all the time.

Bit 2: EXTCLKEN. When the EXTCLKEN bit is set, the external clock becomes the source for the internal clock tree, SYSCCLK, which drives most PSoC device clocking functions. All external and internal signals, including the 32 kHz clock, whether derived from the internal low speed

oscillator (ILO) or the crystal oscillator, are synchronized to this clock source. If an external clock is enabled, PLL mode should be off. The external clock input is located on port P1[4]. When using this input, the pin drive mode should be set to High Z (not High Z analog).

Bit 1: IMODIS. When set, the Internal Main Oscillator (IMO) is disabled. If the doubler is enabled (SYSCCLKX2DIS=0), the IMO is forced on.

Bit 0: SYSCCLKX2DIS. When set, the Internal Main Oscillator's doubler is disabled. This results in a reduction of overall device power, on the order of 1 mA. It is advised that any application that does not require this doubled clock should have it turned off.

For additional information, refer to the [OSC_CR2 register on page 293](#).

26. Multiply Accumulate (MAC)



This chapter presents the Multiply Accumulate (MAC) and its associated registers. The MAC block is a fast 8-bit multiplier or a fast 8-bit multiplier with 32-bit accumulate. Refer to [Table 26-1](#) for MAC availability by part number. For a complete table of the MAC registers, refer to the “[Summary Table of the System Resource Registers](#)” on page 455. For a quick reference of all PSoC registers in address order, refer to the [Register Details](#) chapter on page 147.

26.1 Architectural Description

The MAC is a register-based system resource. Its only interface is the system bus; therefore, there are no special clocks or enables that are required to be sourced from digital or analog PSoC blocks. In devices with more than one MAC block, each MAC is completely independent of the other. Refer to [Table 26-1](#) for MAC availability by part number. Note that the CY8C22x13, CY8C21x34, CY8C21x23, CY7C603xx, and CYWUSB6953 do not have MAC functionality.

The architectural presentation of the MAC is illustrated in [Figure 26-1](#).

Table 26-1. MAC Availability for PSoC Devices

PSoC Part Number	Number of MAC Blocks
CY8C29x66 CY8CPLC20 CY8CLEd16P01	2
CY8C27x43	1
CY8C24x94	2
CY8C24x23	1
CY8C24x23A	1
CY8C22x13	0
CY8C21x34	0
CY8C21x23	0
CY7C64215	2
CY7C603xx	0
CYWUSB6953	0
CY8CNP1xx	2

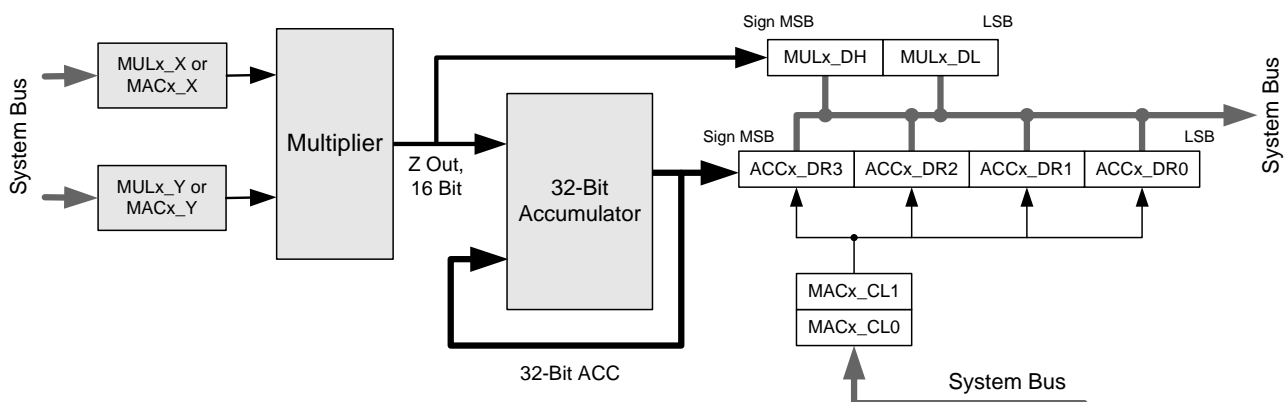

Figure 26-1. MAC Block Diagram

26.2 Application Description

26.2.1 Multiplication with No Accumulation

For simple multiplication, the MAC block accepts two 8-bit signed numbers as the multiplicands for a multiply operation. The product of the multiplication is stored in a 16-bit signed form. Up to four registers are involved with simple multiplication: MULx_X, MULx_Y, MULx_DH, and MULx_DL.

To execute a multiply, simply write a value to either the MULx_X or MULx_Y registers. Immediately after the write of the multiplicand, the product is available at registers MULx_DH and MULx_DL. After reset of the part at power up or after an external reset, the MAC registers will not be reset to zero. Therefore, after the write of the first multiplicand, the product is indeterminate. After the write of the second multiplicand, the product registers are updated with the product of the first and second multiplicands (assuming one of the writes was to MULx_X and the other was to MULx_Y). Multiplication is associative so the order in which you write to X and Y does not matter.

26.2.2 Accumulation After Multiplication

Accumulation of products is a feature that is implemented on top of simple multiplication. When using the MAC to accumulate the products of successive multiplications, two 8-bit signed values are used for input. The product of the multiplication is accumulated as a 32-bit signed value.

The user has the choice to either cause a multiply/accumulate function to take place or a multiply only function. The user selects which operation is performed by choosing of input register. The multiply function occurs immediately whenever the MULx_X or the MULx_Y multiplier input registers are written, and the result is available in the MULx_DH and MULx_DL multiplier result registers, as discussed in the [26.2.1 Multiplication with No Accumulation](#) section. The multiply/accumulate function is executed whenever there is a write to the MACx_X or the MACx_Y multiply/accumulate input registers; the result is available in the ACCx_DR3, ACCx_DR2, ACCx_DR1, and ACCx_DR0 accumulator result registers. A write to the MULx_X or MACx_X registers is input as the X value to both the multiply and multiply/accumulate functions. A write to the MULx_Y or MACx_Y registers is input as the Y value to both the multiply and multiply/accumulate functions. A write to the MACx_CL0 or MACx_CL1 registers will clear the value in the four accumulate registers.

To clear the accumulated products, simply write to either of the MACx_CLx registers.

26.3 Register Definitions

In PSoC devices with more than one MAC block, there will be one of the following registers for each block. The registers in this section are listed in address order. Refer to the table titled "[MAC Availability for PSoC Devices](#)" on page 469 to determine how many MAC blocks are available for your PSoC device. Note that the CY8C22x13, CY8C21x34, CY8C21x23, CY7C603xx, and CYWUSB6953 do not have MAC functionality.

The following registers are associated with the MAC PSoC Blocks. Each register description has an associated register table showing the bit structure for that register. The 'X' in the Access column of some register tables signify that the value after power on reset is unknown. For a complete table of the MAC registers, refer to the "[Summary Table of the System Resource Registers](#)" on page 455.

26.3.1 MULx_X Register

Addr.	Name	Bit 7	Bit 6	Bit 5	Bit 4	Bit 3	Bit 2	Bit 1	Bit 0	Access
0,A8h	MUL1_X	Data[7:0]								W : XX
0,E8h	MUL0_X	Data[7:0]								W : XX

LEGEND

X The value after power on reset is unknown.

The Multiply Input X Register (MULx_X) is one of two multiplicand registers for the signed 8-bit multiplier in the PSoC MAC.

Bits 7 to 0: Data[7:0]. The multiply X (MULx_X) register is one of two multiplicand registers for the signed 8-bit multi-

plier in the PSoC MAC. When these write only registers are written, the product of the written value and the current value of the MULx_X registers are calculated.

For additional information, refer to the [MULx_X register on page 204](#).

26.3.2 MULx_Y Register

Addr.	Name	Bit 7	Bit 6	Bit 5	Bit 4	Bit 3	Bit 2	Bit 1	Bit 0	Access
0,A9h	MUL1_Y	Data[7:0]								W : XX
0,E9h	MUL0_Y	Data[7:0]								W : XX

LEGEND

X The value after power on reset is unknown.

The Multiply Input Y Register (MULx_Y) is one of two multiplicand registers for the signed 8-bit multiplier in the PSoC MAC.

Bits 7 to 0: Data[7:0]. The multiply Y (MULx_Y) register is one of two multiplicand registers for the signed 8-bit multi-

plier in the PSoC MAC. When these write only registers are written, the product of the written value and the current value of the MULx_Y registers are calculated.

For additional information, refer to the [MULx_Y register on page 205](#).

26.3.3 MULx_DH Register

Addr.	Name	Bit 7	Bit 6	Bit 5	Bit 4	Bit 3	Bit 2	Bit 1	Bit 0	Access
0,AAh	MUL1_DH	Data[7:0]								R : XX
0,EAh	MUL0_DH	Data[7:0]								R : XX

LEGEND

X The value after power on reset is unknown.

The Multiply Result High Byte Register (MULx_DH) holds the most significant byte of the 16-bit product.

Bits 7 to 0: Data[7:0]. The product of the multiply operation on the MULx_X and MULx_Y registers is stored as a signed 16-bit value. The read only multiply data high (MUL0_DH

and MUL1_DH) registers hold the most significant byte of the 16-bit product.

For additional information, refer to the [MULx_DH register on page 206](#).

26.3.4 MULx_DL Register

Add.	Name	Bit 7	Bit 6	Bit 5	Bit 4	Bit 3	Bit 2	Bit 1	Bit 0	Access
0,ABh	MUL1_DL	Data[7:0]								R : XX
0,EBh	MUL0_DL	Data[7:0]								R : XX

LEGEND

X The value after power on reset is unknown.

The Multiply Result Low Byte Register (MULx_DL) holds the least significant byte of the 16-bit product.

Bits 7 to 0: Data[7:0]. The product of the multiply operation on the MULx_X and MULx_Y registers is stored as a signed 16-bit value. The read only multiply data low (MUL0_DL and

MUL1_DL) registers hold the least significant byte of the 16-bit product.

For additional information, refer to the [MULx_DL register on page 207](#).

26.3.5 MACx_X/ACCx_DR1 Register

Add.	Name	Bit 7	Bit 6	Bit 5	Bit 4	Bit 3	Bit 2	Bit 1	Bit 0	Access
0,ACh	MAC1_X/ ACC1_DR1	Data[7:0]								RW : 00
0,ECh	MAC0_X/ ACC0_DR1	Data[7:0]								RW : 00

The Accumulator Data Register 1 (MACx_X/ACCx_DR1) is the multiply accumulate X register and the second byte of the accumulated value.

Bits 7 to 0: Data[7:0]. This register performs two distinct functions; therefore, two names are used to refer to the same address. When the address is written, a multiply operation with accumulation is performed. The multiply accumulate X (MACx_X) register is one of the two multiplicand registers for the signed 8-bit multiply with accumulate operation. When this register is written, the product of the written

value and the current value of the MACx_Y register is calculated, then that product is added to the 32-bit accumulator's value. When this address is read, the accumulator's data register 1 is read. This register holds the second of four bytes used to hold the accumulator's value. This byte is the most significant of the lower 16 bits of the accumulator's value.

For additional information, refer to the [MACx_X/ACCx_DR1 register on page 208](#).

26.3.6 MACx_Y/ACCx_DR0 Register

Add.	Name	Bit 7	Bit 6	Bit 5	Bit 4	Bit 3	Bit 2	Bit 1	Bit 0	Access
0,ADh	MAC1_Y/ ACC1_DR0	Data[7:0]								RW : 00
0,EDh	MAC0_Y/ ACC0_DR0	Data[7:0]								RW : 00

The Accumulator Data Register 0 (MACx_Y/ACCx_DR0) is the multiply accumulate Y register and the first byte of the accumulated value.

Bits 7 to 0: Data[7:0]. This register performs two distinct functions; therefore, two names are used to refer to the same address. When the address is written, a multiply operation with accumulation is performed. The multiply accumulate Y (MACx_Y) register is one of the two multiplicand registers for the signed 8-bit multiply with accumulate opera-

tion. When this register is written, the product of the written value and the current value of the MACx_X register is calculated, then that product is added to the 32-bit accumulator's value. When this address is read, the accumulator's data register 0 is read. This register holds the least significant of four bytes used to hold the accumulator's value.

For additional information, refer to the [MACx_Y/ACCx_DR0 register on page 209](#).

26.3.7 MACx_CL0/ACCx_DR3 Register

Add.	Name	Bit 7	Bit 6	Bit 5	Bit 4	Bit 3	Bit 2	Bit 1	Bit 0	Access
0,AEh	MAC1_CL0/ ACC1_DR3	Data[7:0]								RW : 00
0,EEh	MAC0_CL0/ ACC0_DR3	Data[7:0]								RW : 00

The Accumulator Data Register 3 (MACx_CL0/ACCx_DR3) is an accumulator clear register and the fourth byte of the accumulated value.

Bits 7 to 0: Data[7:0]. This register performs two distinct functions; therefore, two names are used to refer to the same address. When the address is written with any value,

all 32-bits of the accumulator are reset to zero. When this address is read, the accumulator's data register 3 is read. This register holds the most significant of four bytes used to hold the accumulator's value.

For additional information, refer to the [MACx_CL0/ACCx_DR3 register on page 210](#).

26.3.8 MACx_CL1/ACCx_DR2 Register

Add.	Name	Bit 7	Bit 6	Bit 5	Bit 4	Bit 3	Bit 2	Bit 1	Bit 0	Access
0,AFh	MAC1_CL1/ ACC1_DR2	Data[7:0]								RW : 00
0,EFh	MAC0_CL1/ ACC0_DR2	Data[7:0]								RW : 00

The Accumulator Data Register 2 (MACx_CL1/ACCx_DR2) is an accumulator clear register and the third byte of the accumulated value.

Bits 7 to 0: Data[7:0]. This register performs two distinct functions; therefore, two names are used to refer to the same address. When the address is written with any value, all 32 bits of the accumulator are reset to zero. When this

address is read, the accumulator's data register 2 is read. This register holds the third of four bytes used to hold the accumulator's value. This byte is the least significant of the upper 16 bits of the accumulator's value.

For additional information, refer to the [MACx_CL1/ACCx_DR2 register on page 211](#).

Multiply Accumulate (MAC)

27. Decimator



This chapter explains the PSoC Type 1 and Type 2 Decimator blocks, and their associated registers. The decimator blocks are a hardware assist for digital signal processing applications. The decimator may be used for delta-sigma analog to digital converters and incremental analog to digital converters. For a complete table of the decimator registers, refer to the “Summary Table of the System Resource Registers” on page 455. For a quick reference of all PSoC registers in address order, refer to the Register Details chapter on page 147.

27.1 Architectural Description

Depending on the PSoC device, there are two types of decimator blocks: type 1 and type 2 (see Table 27-1). Both types are described in the following sections. Note that the CY8C21x34, CY8C21x23, CY7C603xx, and CYWUSB6953 PSoC devices do not support the decimator resource.

Table 27-1. Decimator Availability for PSoC Devices

PSoC Part Number	Type 1 Decimator Block	Type 2 Decimator Block
CY8C29x66 CY8CPLC20 CY8CLED16P01		✓
CY8C27x43	✓	
CY8C24x94		✓
CY8C24x23	✓	
CY8C24x23A	✓	
CY8C22x13	✓	
CY7C64215		✓
CY8CNP1xx		✓

27.1.1 Type 1 Decimator Block

The type 1 decimator block may perform either a single or double integration of the discrete-time, discrete-amplitude signal applied to the data input pin of the block. The integrated value may be up to 16 bits long and is read or cleared by way of a register interface.

Because the data input to the type 1 decimator is only one bit, the input signal's amplitude can only be one of two values:

Table 27-2. Type 1 Input Signal Amplitude

Encoding	Weight
0	-1
1	+1

Because the input signal is a discrete-time signal, the weight of each encoding is analogous to the area under the signal for that instant in time. Therefore, to integrate the signal, the sum of the weights must be calculated over a period of time. When the type 1 decimator is configured as a single integrator, this is exactly what happens. For each period of the input clock, the current area (integral value) is either increased by one (weight = +1, encoding = 1) or decreased by one (weight = -1, encoding = 0).

The major functional units within the type 1 decimator block are illustrated below.

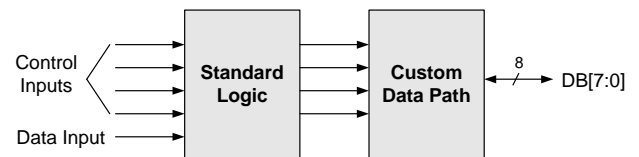

Figure 27-1. Type 1 Decimator Architecture

The type 1 decimator may be divided into two major functional units: a logic block composed of standard logic cells and a custom digital data path block. The logic block interfaces to all of the decimator block pins, except for the data bus. The logic block takes the decimator's inputs and creates the necessary control input to the custom block. The custom block is where the adding and storage of accumulated values occurs. The custom block also interfaces to the data bus.

The principle of operation of a Sinc2 decimation filter is inferred in Figure 27-2 and Equation 1. The decimator's custom data path follows the Accumulation stage of Figure 27-2, in principle. The Differentiation is accomplished with external firmware in user modules.

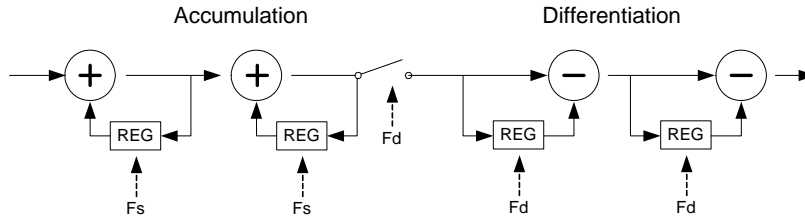

Figure 27-2. Sinc² Filter Block Diagram

$$H(z) = \text{Transfer function of Sinc}^N \text{ filter with a decimation rate of } M$$

$$H(z) = (1/M)^N (1-Z^{-M})^N (1/(1-Z^{-1}))^N$$

Sinc² Transfer Function

Equation 1

There are three 16-bit internal registers in the type 1 decimator: A0, A1, and AB (see Figure 27-3). The A0 register is used to store the 16-bit sum from the Data + A0 calculation. The A1 register is used to store the 16-bit sum from the A0 + A1 calculation. The AB register is the one that is readable by way of the data bus. The A0 and A1 registers are not accessible from outside the block.

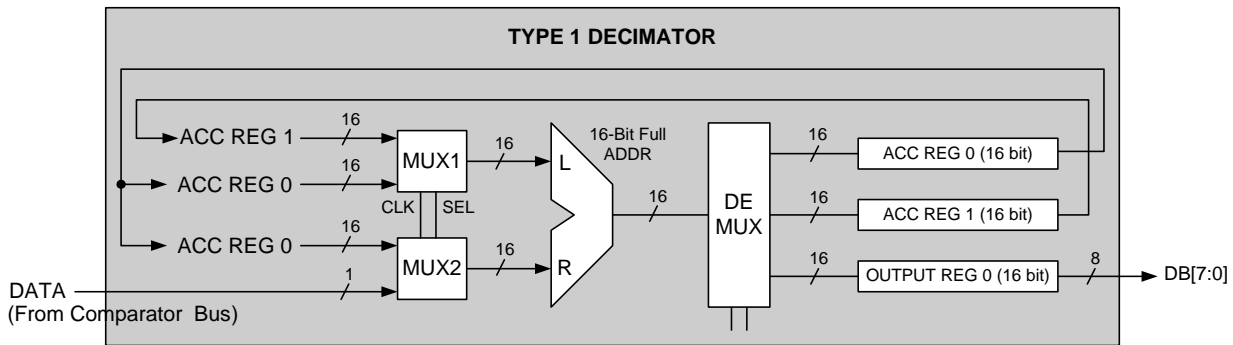

Figure 27-3. Type 1 Decimator Custom Data Path

27.1.2 Type 2 Decimator Block

The type 2 decimator block is only available for the CY8CPLC20, CY8CLED16P01, CY8CNP1xx, and CY8C29x66. Unlike the type 1 block, the type 2 block is a full hardware version of a Sinc2 filter. Integration and re-sampling/differentiation is accomplished in this block. Depending on the operating mode, little or no processing is required on the final output. This greatly reduces the CPU overhead requirement for analog-to-digital conversion functionality.

The major functional units within the type 2 decimator block are shown below.

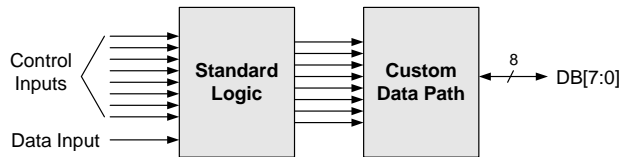

Figure 27-4. Type 2 Decimator Architecture

Like the type 1 decimator block, the type 2 decimator block may also be divided into two major functional units: A logic block composed of standard cells and a custom data path block. The architecture of the custom data path block is shown in Figure 27-5. The essential function of the custom data path block is not just to integrate the single bit data stream over a specific time period, but also to re-sample/differentiate it to obtain the filtered data. Thus, the type 2 decimator block does not depend on external firmware code to perform the decimation process. It does the entire Sinc2 filtering on its own. The type 2 custom data path block implements the 17-bit math, as described in Figure 27-5. The Accumulation and Differentiation tasks follow Figure 27-2 and Equation 1 in principle.

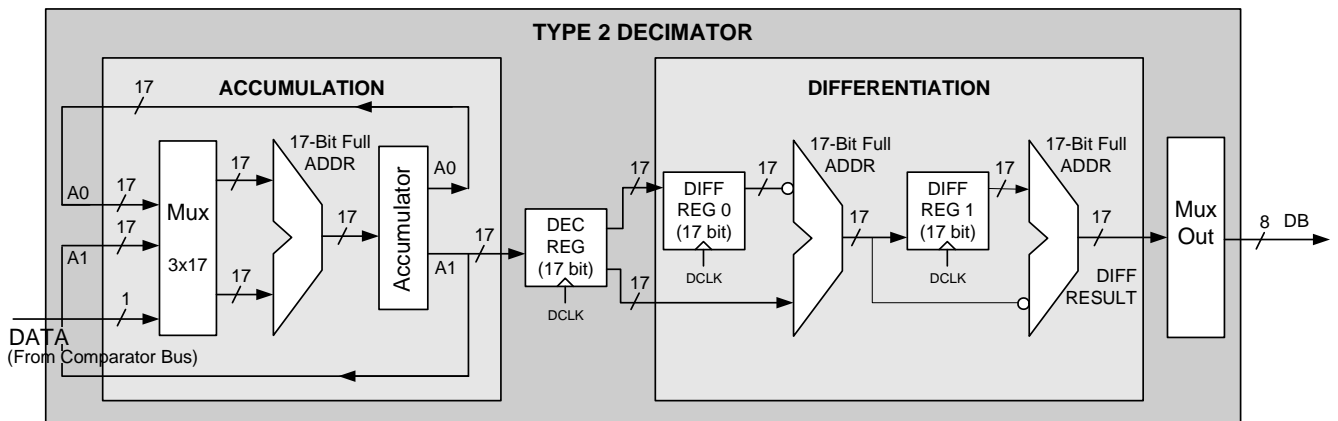

Figure 27-5. Type 2 Decimator Custom Data Path

27.1.3 Decimator Scenarios

The architecture of the type 2 decimator block allows the user the option of using an external digital block timer or an internal timer for decimation and interrupt purposes. Type 2, in the CY8CPLC20, CY8CLED16P01, CY8CNP1xx, and CY8C29x66 PSoC devices, requires the use of an external timer. The scenarios involving the usage of type 2 blocks in a programmable system-on-chip PSoC device are presented in [Table 27-3](#).

Table 27-3. Decimator Type 2 Scenarios for PSoC Devices

PSoC Device	Decimator Type 2 Scenarios	Highlights of Type 2 Decimator Block Usage
CY8C29x66 CY8CPLC20 CY8CLED16P01 CY8CNP1xx	Special case of single type 2 decimator block.	Uses the external timer for decimation and interrupt processes. Uses Control register: DEC_CR2: 1, E7h. Other associated registers are DEC_DH, DEC_DL, DEC_CR0, DEC_CR1*.
CY8C24x94, CY7C64215	Generic case of single type 2 decimator block.	Uses either external or internal timer. Uses Control register: DEC_CR2: 1, E7h. Other associated registers are DEC_DH, DEC_DL, DEC_CR0, DEC_CR1*.

* The DEC_CR1 bit 7 is reserved as opposed to the "ECNT" option available in the PSoC CY8C27x43, CY8C24x23, CY8C24x23A, and CY8C22x13 devices.

27.2 PSoC Device Distinctions

The DEC_CR1 register's bit 7 (ECNT) is only available in PSoC devices with a type 1 decimator and is reserved in PSoC devices with a type 2 decimator. Refer to the table titled "[Decimator Availability for PSoC Devices](#)" on page 475 to determine which type of decimator your PSoC device uses.

27.3 Register Definitions

The following registers are associated with the Decimator and are listed in address order. Each register description has an associated register table showing the bit structure for that register. The bits that are grayed out in the tables are reserved bits and are not detailed in the register description that follows. Reserved bits should always be written with a value of '0'. For a complete table of decimator registers, refer to the “Summary Table of the System Resource Registers” on page 455.

27.3.1 DEC_DH Register

Address	Name	Bit 7	Bit 6	Bit 5	Bit 4	Bit 3	Bit 2	Bit 1	Bit 0	Access
0,E4h	DEC_DH	Data High Byte[7:0]								RC : XX

LEGEND

C Clearable register or bits.

X The value for power after reset is unknown.

The Decimator Data High Register (DEC_DH) is a dual purpose register and is used to read the high byte of the decimator's output or clear the decimator.

Bits 7 to 0: Data High Byte[7:0].

When the register is read, the most significant byte of the 16-bit decimator value is returned. Depending on how the decimator is configured, this value is either the result of the second integration or the high byte of the 16-bit counter. Whereas in the case with the CY8CPLC20, CY8CLED16P01, CY8CNP1xx, and CY8C29x66, this value can also be the result of the second differentiation.

The second function of the DEC_DH register is activated whenever the register is written: That function is to clear the decimator value. When the DEC_DH register is written, the decimator's value is cleared regardless of the value written. Either the DEC_DH or DEC_DL registers may be written to clear the decimator's value. Note that this register does not reset to 00h. The DEC_DH register resets to an indeterminate value.

For additional information, refer to the [DEC_DH register on page 243](#).

27.3.2 DEC_DL Register

Address	Name	Bit 7	Bit 6	Bit 5	Bit 4	Bit 3	Bit 2	Bit 1	Bit 0	Access
0,E5h	DEC_DL	Data Low Byte[7:0]								RC : XX

LEGEND

C Clearable register or bits.

X The value for power after reset is unknown.

The Decimator Data Low Register (DEC_DL) is a dual purpose register and is used to read the low byte of the decimator's output or clear the decimator.

Bits 7 to 0: Data Low Byte[7:0]. When the register is read, the most significant byte of the 16-bit decimator value is returned. Depending on how the decimator is configured, this value is either the result of the second integration or the high byte of the 16-bit counter. Whereas in the case with the CY8CPLC20, CY8CLED16P01, CY8CNP1xx, and CY8C29x66, this value can also be the result of the second differentiation.

The second function of the DEC_DL register is activated whenever the register is written: That function is to clear the decimator value. When the DEC_DL register is written, the decimator's value is cleared regardless of the value written. Either the DEC_DH or DEC_DL registers may be written to clear the decimator's value. Note that this register does not reset to 00h. The DEC_DL register resets to an indeterminate value.

For additional information, refer to the [DEC_DL register on page 244](#).

27.3.3 DEC_CR0 Register

Address	Name	Bit 7	Bit 6	Bit 5	Bit 4	Bit 3	Bit 2	Bit 1	Bit 0	Access
0,E6h	DEC_CR0	IGEN[3:0]				ICLKS0	DCOL[1:0]		DCLKS0	RW : 00

The Decimator Control Register 0 (DEC_CR0) contains control bits to access hardware support for both the Incremental ADC and the DELISG ADC.

This register can only be used with four and two analog column PSoC devices.

Bits 7 to 4: IGEN[3:0]. For incremental support, the upper four bits, IGEN[3:0], select which column comparator bit is gated by the output of a digital block. The output of that digital block is typically a PWM signal; the high time of which corresponds to the ADC conversion period. This ensures that the comparator output is only processed for the precise conversion time. The digital block selected for the gating function is controlled by ICLKS0 in this register, and ICLKS3, ICLKS2, and ICLKS1 bits in the DEC_CR1 register.

Bit 3: ICLKS0. In conjunction with the ICLKS1, ICLKS2, and ICLKS3 bits in the DEC_CR1 register, these bits select up to 1 of 16 digital blocks (depending on PSoC device

resources) to provide the gating signal for an incremental ADC conversion.

Bits 2 and 1: DCOL[1:0]. The DELSIG ADC uses the hardware decimator to do a portion of the post processing computation on the comparator signal. DCOL[1:0] selects the column source for the decimator data (comparator bit) and clock input (PHI clocks).

Bit 0: DCLKS0. The decimator requires a timer signal to sample the current decimator value to an output register that may subsequently be read by the CPU. This timer period is set to be a function of the DELSIG conversion time and may be selected from up to one of eight digital blocks (depending on the PSoC device resources) with DCLKS0 in this register and DCLKS3, DCLKS2, and DCLKS1 in the DEC_CR1 register.

For additional information, refer to the [DEC_CR0 register on page 245](#).

27.3.4 DEC_CR1 Register

Address	Name	Cols.	Bit 7	Bit 6	Bit 5	Bit 4	Bit 3	Bit 2	Bit 1	Bit 0	Access
0,E7h	DEC_CR1	4		IDEC	ICLKS3	ICLKS2	ICLKS1	DCLKS3	DCLKS2	DCLKS1	RW : 00
		2	ECNT	IDEC	ICLKS3	ICLKS2	ICLKS1	DCLKS3	DCLKS2	DCLKS1	RW : 00

The Decimator Control Register 1 (DEC_CR1) is used to configure the decimator prior to using it.

This register can only be used with four and two analog column PSoC devices.

Depending on how many analog columns your PSoC device has (see the Cols. column in the register table above), only certain bits are accessible to be read or written.

Bit 7: ECNT. ECNT is a mode bit that controls operation of the decimator hardware block. By default, the decimator is set to a double integrate function for use in hardware DELSIG processing. When the ECNT bit is set, the decimator block converts to a single integrate function. This gives the equivalent of a 16-bit counter suitable for use in hardware support for an incremental ADC function.

This bit is only available in PSoC devices with a type 1 decimator and is reserved in PSoC devices with a type 2 decimator.

Refer to the table titled “[Decimator Availability for PSoC Devices](#)” on page 475 to determine which type of decimator your PSoC device uses.

Bit 6: IDEC. Any function using the decimator requires a digital block timer to sample the current decimator value. Normally, the positive edge of this signal causes the decimator output to be sampled. However, when the IDEC bit is set, the negative edge of the selected digital block input causes the decimator value to be sampled.

Bits 5 to 0: ICLKSx and DCLKSx. The ICLKS3, ICLKS2, ICLKS1, DCLKS3, DCLKS2, and DCLKS1 bits in this register select the digital block sources for Incremental and DELSIG ADC hardware support (see the DEC_CR0 register).

For additional information, refer to the [DEC_CR1 register on page 247](#).

27.3.5 DEC_CR2 Register

Address	Name	Bit 7	Bit 6	Bit 5	Bit 4	Bit 3	Bit 2	Bit 1	Bit 0	Access
1,E7h	DEC_CR2	Mode[1:0]		Data Out Shift[1:0]		Data Format	Decimation Rate[2:0]			RW : 00

The Decimator Control Register 2 (DEC_CR2) is used to configure the decimator before use.

This register can only be used with the CY8CPLC20, CY8CLED16P01, CY8C29x66, CY8C24x94, CY8CNP1xx, and CY7C64215 PSoC devices.

Bits 7 and 6: Mode[1:0]. These bits signify the mode of operation of the type 2 decimator block. A '00' in Mode enables the user to configure the type 2 block to match a type 1 behavior, where the input data stream is integrated and an external firmware performs the re-sampling/differentiation process required to complete the Sinc2 filtering. If Mode is '01', the decimator block can be used in an incremental mode. For the type 1 decimator block, this function is performed by bit 7 of the DEC_CR1 register. If a decimator-based incremental ADC is to be configured, the Mode bits are set to '01'. The full algorithm (when Mode is set to '10') implies the usage of the decimator as a Sinc2 block, to be used in delta-sigma ADCs. The selection of '11' for Mode is reserved.

Bits 5 and 4: Data Out Shift[1:0]. These bits are determined from [Table 27-4](#), which enumerates the available operating modes. To compute the effective resolution, the following equations are used:

$$\begin{aligned} \text{Single Modulator: } & (\log_2(\text{Decimation Rate}) - 1) * 1.5 \\ \text{Double Modulator: } & (\log_2(\text{Decimation Rate}) - 1) * 2 \end{aligned}$$

Table 27-4. Decimator Data Output Shift

Decimation Rate	Modulator Type	Effective Resolution	Shift
32	Single	6	4
32	Double	8	2
64	Single	*8 (7.5)	4
64	Double	10	2
128	Single	9	5
128	Double	12	2
256	Single	*11 (10.5)	5
256	Double	14	2

Bit 3: Data Format. The Data Format bit can be weighted as signed (2s complement output) or unsigned (offset binary data).

Bits 2 to 0: Decimation Rate[2:0]. The Decimation Rate for type 2 decimator blocks is '000', since the external timer controls the decimation rate and interrupt.

For additional information, refer to the [DEC_CR2 register on page 297](#).

This chapter explains the I²C™ block and its associated registers. The I2C communications block is a serial processor designed to implement a complete I2C slave or master. For a complete table of the I2C registers, refer to the “[Summary Table of the System Resource Registers](#)” on page 455. For a quick reference of all PSoC registers in address order, refer to the [Register Details](#) chapter on page 147.

28.1 Architectural Description

The I2C communications block is a serial to parallel processor, designed to interface the PSoC device to a two-wire I2C serial communications bus. To eliminate the need for excessive M8C microcontroller intervention and overhead, the block provides I2C specific support for status detection and generation of framing bits.

The I2C block directly controls the data (SDA) and clock (SCL) signals to the external I2C interface, through connections to two dedicated GPIO pins. The PSoC device firmware interacts with the block through IO (input/output) register reads and writes, and firmware synchronization will be implemented through polling and/or interrupts.

PSoC I2C features include:

- Master/Slave, Transmitter/Receiver operation
- Byte processing for low CPU overhead
- Interrupt or polling CPU interface
- Master clock rates: 50K, 100K, 400K
- Multi-master clock synchronization
- Multi-master mode arbitration support
- 7- or 10-bit addressing (through firmware support)
- SMBus operation (through firmware support)

Hardware functionality provides basic I2C control, data, and status primitives. A combination of hardware support and firmware command sequencing provides a high degree of flexibility for implementing the required I2C functionality.

Hardware limitations in regards to I2C are as follows:

1. There is no hardware support for automatic address comparison. When Slave mode is enabled, every slave address will cause the block to interrupt the PSoC device and possibly stall the bus.
2. Since receive and transmitted data are not buffered, there is no support for automatic receive acknowledge. The M8C microcontroller must intervene at the boundary of each byte and either send a byte or ACK received bytes.

The I2C block is designed to support a set of primitive operations and detect a set of status conditions specific to the I2C protocol. These primitive operations and conditions are manipulated and combined at the firmware level to support the required data transfer modes. The CPU will set up control options and issue commands to the unit through IO writes and obtain status through IO reads and interrupts.

The block operates as either a slave, a master, or both. When enabled in Slave mode, the unit is always listening for a Start condition, or sending or receiving data. Master mode can work in conjunction with Slave mode. The master supplies the ability to generate the START or STOP condition and determine if other masters are on the bus. For Multi-Master mode, clock synchronization is supported. If Master mode is enabled and Slave mode is not enabled, the block does not generate interrupts on externally generated Start conditions.

28.1.1 Basic I²C Data Transfer

[Figure 28-1](#) shows the basic form of data transfers on the I2C bus with a 7-bit address format. (For a more detailed description, see the Philips Semiconductors (now NXP Semiconductors) I²C-Bus Specification, version 2.1.)

A Start condition (generated by the master) is followed by a data byte, consisting of a 7-bit slave address (there is also a 10-bit address mode) and a Read/Write (RW) bit. The RW bit sets the direction of data transfer. The addressed slave is required to acknowledge (ACK) the bus by pulling the data line low during the ninth bit time. If the ACK is received, the transfer may proceed and the master can transmit or receive an indeterminate number of bytes, depending on the RW direction. If the slave does not respond with an ACK for any reason, a Stop condition is generated by the master to terminate the transfer or a Restart condition may be generated for a retry attempt.

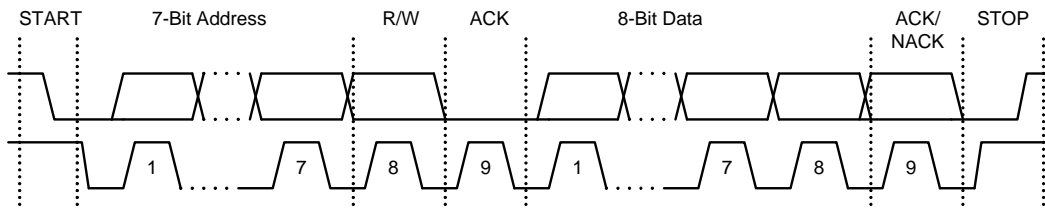

Figure 28-1. Basic I²C Data Transfer with 7-Bit Address Format

28.2 Application Description

28.2.1 Slave Operation

Assuming Slave mode is enabled, it is continually listening to or on the bus for a Start condition. When detected, the transmitted Address/RW byte is received and read from the I2C block by firmware. At the point where eight bits of the address/RW byte have been received, a byte complete interrupt is generated. On the following low of the clock, the bus is stalled by holding the SCL line low, until the PSoC device has had a chance to read the address byte and compare it to its own address. It will issue an ACK or NACK command based on that comparison.

If there is an address match, the RW bit determines how the PSoC device will sequence the data transfer in Slave mode, as shown in the two branches of Figure 28-2. I2C handshaking methodology (slave holds the SCL line low to “stall” the bus) will be used as necessary, to give the PSoC device time to respond to the events and conditions on the bus. Figure 28-2 is a graphical representation of a typical data transfer from the slave perspective.

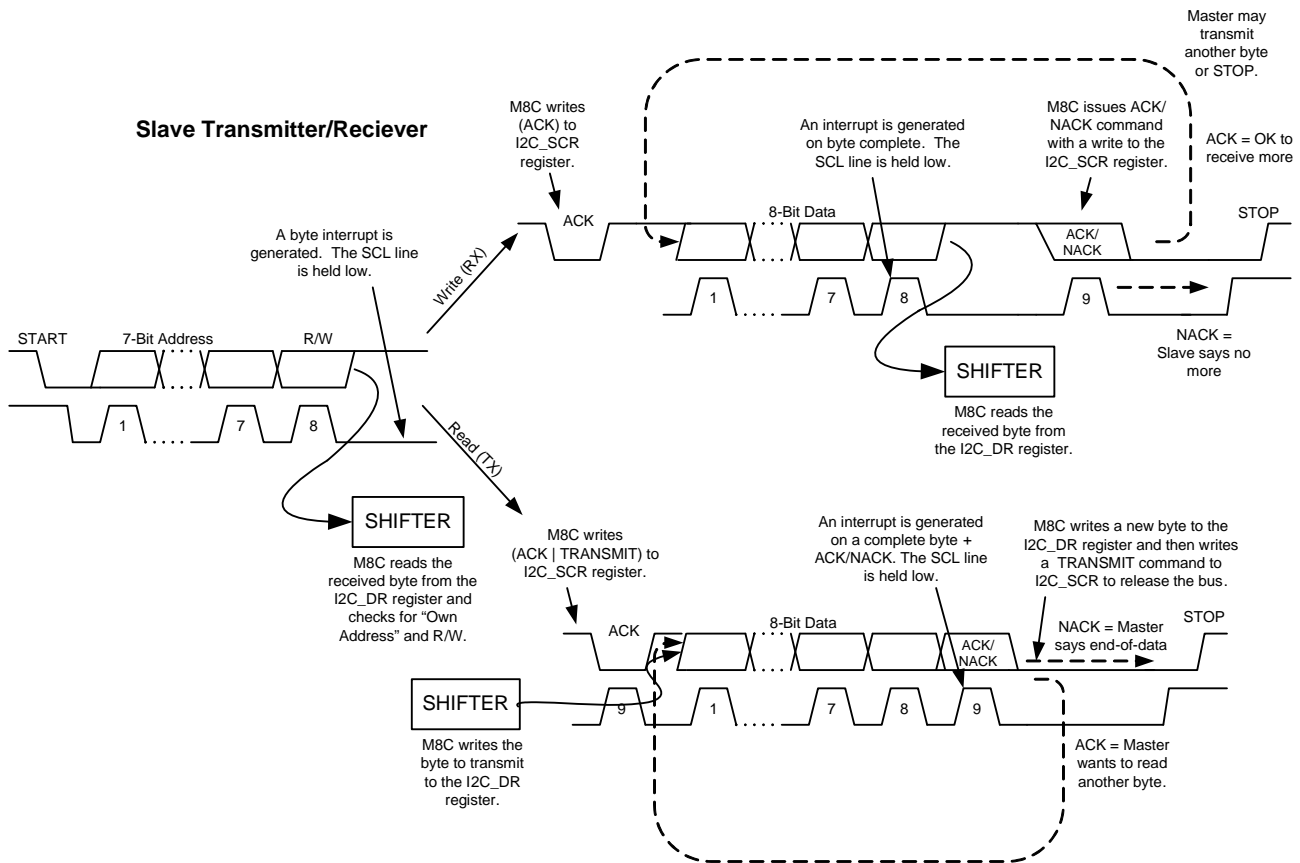

Figure 28-2. Slave Operation

28.2.2 Master Operation

To prepare for a Master mode transaction, the PSoC device must determine if the bus is free. This is done by polling the BusBusy status. If busy, interrupts can be enabled to detect a Stop condition. Once it is determined that the bus is available, firmware should write the address byte into the I2C_DR register and set the Start Gen bit in the I2C_MSCR register.

If the slave sub-unit is not enabled, the block is in Master Only mode. In this mode, the unit does not generate interrupts or stall the I2C bus on externally generated Start conditions.

In a multi-master environment there are two additional outcomes possible:

1. The PSoC device was too late to reserve the bus as a master, and another master may have generated a Start and sent an Address/RW byte. In this case, the unit as a master will fail to generate a Start and is forced into

Slave mode. The Start will be pending and eventually occur at a later time when the bus becomes free. When the interrupt occurs in Slave mode, the PSoC device can determine that the Start command was unsuccessful by reading the I2C_MSCR register Start bit, which is reset on successful Start from this unit as master. If this bit is still a '1' on the Start/Address interrupt, it means that the unit is operating in Slave mode. In this case, the data register has the master's address data.

2. If another master starts a transmission at the same time as this unit, arbitration occurs. If this unit loses the arbitration, the LostArb status bit is set. In this case, the block releases the bus and switches to Slave operation. When the Start/Address interrupt occurs, the data register has the winning master's address data.

Figure 28-3 is a graphical representation of a typical data transfer from the master perspective.

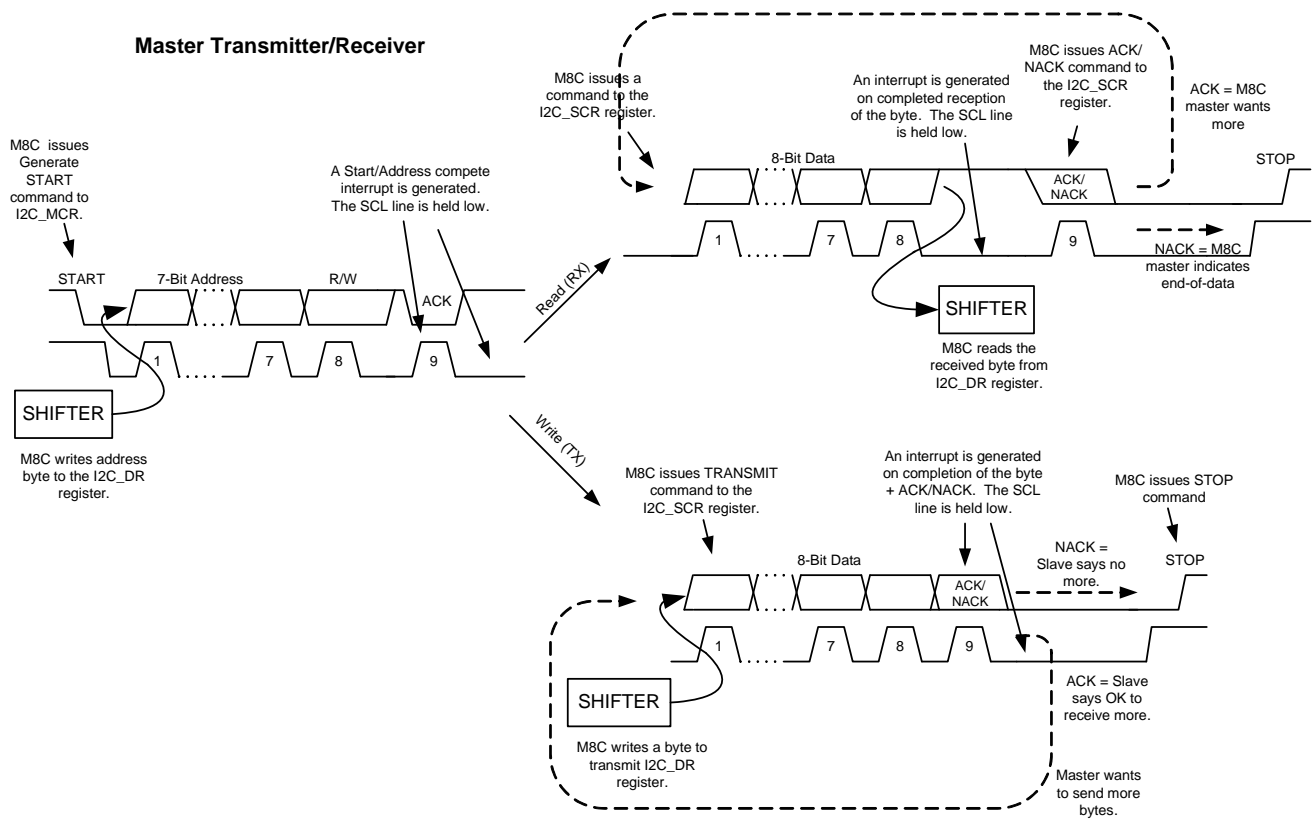

Figure 28-3. Master Operation

28.3 Register Definitions

The following registers are associated with I2C and are listed in address order. Each register description has an associated register table showing the bit structure for that register. The bits in the tables that are grayed out are reserved bits and are not detailed in the register descriptions that follow. Reserved bits should always be written with a value of '0'. For a complete table of I2C registers, refer to the “Summary Table of the System Resource Registers” on page 455.

28.3.1 I2C_CFG Register

Address	Name	Bit 7	Bit 6	Bit 5	Bit 4	Bit 3	Bit 2	Bit 1	Bit 0	Access
0,D6h	I2C_CFG		PSelect	Bus Error IE	Stop IE	Clock Rate[1:0]		Enable Master	Enable Slave	RW : 00

The I2C Configuration Register (I2C_CFG) is used to set the basic operating modes, baud rate, and selection of interrupts.

The bits in this register control baud rate selection and optional interrupts. The values are typically set once for a given configuration. The bits in this register are all RW.

Table 28-1. I2C_CFG Configuration Register

Bit	Access	Description	Mode
6	RW	I2C Pin Select 0 = P1[7], P1[5] 1 = P1[1], P1[0]	Master/ Slave
5	RW	Bus Error IE Bus error interrupt enable. 0 = Disabled. 1 = Enabled. An interrupt is generated on the detection of a Bus Error.	Master Only
4	RW	Stop IE Stop interrupt enable. 0 = Disabled. 1 = Enabled. An interrupt is generated on the detection of a Stop Condition.	Master/ Slave
3:2	RW	Clock Rate 00 = 100K Standard Mode 01 = 400K Fast Mode 10 = 50K Standard Mode 11 = Reserved	Master/ Slave
1	RW	Enable Master 0 = Disabled 1 = Enabled	Master/ Slave
0	RW	Enable Slave 0 = Disabled 1 = Enabled	Master/ Slave

Bit 6: PSelect. With the default value of zero, the I2C pins are P1[7] for clock and P1[5] for data. When this bit is set, the pins for I2C switch to P1[1] for clock and P1[0] for data. This bit may not be changed while either the Enable Master or Enable Slave bits are set. However, the PSelect bit may be set at the same time as the enable bits. The two sets of pins that may be used on I2C are not equivalent. The default set, P1[7] and P1[5], are the preferred set. The alternate set,

P1[1] and P1[0], are provided so that I2C may be used with 8-pin PSoC parts.

If In-circuit System Serial Programming (ISSP) is to be used and the alternate I2C pin set is also used, it is necessary to take into account the interaction between the PSoC Test Controller and the I2C bus. The interface requirements for ISSP should be reviewed to ensure that they are not violated.

Even if ISSP is not used, pins P1[1] and P1[0] will respond differently to a POR or XRES event than other IO pins. After an XRES event, both pins are pulled down to ground by going into the resistive zero Drive mode, before reaching the High Z Drive mode. After a POR event, P1[0] will drive out a one, then go to the resistive zero state for some time, and finally reach the High Z drive mode state. After POR, P1[1] will go into a resistive zero state for a while, before going to the High Z Drive mode.

Another issue with selecting the alternate I2C pins set is that these pins are also the crystal pins. Therefore, a crystal may not be used when the alternate I2C pin set is selected.

Bit 5: Bus Error IE (Interrupt Enable). This bit controls whether the detection of a bus error will generate an interrupt. A bus error is typically a misplaced Start or Stop.

This is an important interrupt with regards to Master operation. When there is a misplaced Start or Stop on the I2C bus, all slave devices (including this device, if Slave mode is enabled) will reset the bus interface and synchronize to this signal. However, when the hardware detects a bus error in Master Mode operation, the device will release the bus and transition to an idle state. In this case, a Master operation in progress will never have any further status or interrupts associated with it. Therefore, the master may not be able to determine the status of that transaction. An immediate bus error interrupt will inform the master that this transfer did not succeed.

Bit 4: Stop IE (Interrupt Enable). When this bit is set, a master or slave can interrupt on Stop detection. The status bit associated with this interrupt is the Stop Status bit in the Slave Status and Control register. When the Stop Status bit transitions from '0' to '1', the interrupt is generated. It is important to note that the Stop Status bit is not automatically cleared. Therefore, if it is already set, no new interrupts are generated until it is cleared by firmware.

Bits 3 and 2: Clock Rate[1:0]. These bits offer a selection of three sampling and bit rates. All block clocking is based on the SYSCLK input, which is nominally 24 MHz (unless the PSoC device is in external clocking mode). The sampling rate and the baud rate are determined as follows:

- Sample Rate = SYSCLK/Pre-scale Factor
- Baud Rate = 1/(Sample Rate x Samples per Bit)

The nominal values, when using the internal 24 MHz oscillator, are shown in [Table 28-2](#).

Table 28-2. I²C Clock Rates

Clock Rate [1:0]	I2C Mode	SYSCLK Pre-scale Factor	Samples per Bit	Internal Sampling Freq./Period (24 MHz)	Master Baud Rate (nominal)	Start/Stop Hold Time (8 clocks)
00b	Standard	/16	16	1.5 MHz/667 ns	93.75 kHz	5.3 μs
01b	Fast	/4	16	6 MHz/167 ns	375 kHz	1.33 μs
10b	Standard	/16	32	1.5 MHz/667 ns	46.8 kHz	10.7 μs
11b	Reserved					

When clocking the input with a frequency other than 24 MHz (for example, clocking the PSoC device with an external clock), the baud rates and sampling rates will scale accordingly. Whether the block will work in a Standard Mode or Fast Mode system depends on the sample rate. The sample rate must be sufficient to resolve bus events, such as Start and Stop conditions. (See the Philips Semiconductors (now NXP Semiconductors) I²C-Bus Specification, version 2.1, for minimum Start and Stop hold times.)

Bit 1: Enable Master. When this bit is set, the Master Status and Control register is enabled (otherwise it is held in reset) and I2C transfers can be initiated in Master mode. When the master is enabled and operating, the block will clock the I2C bus at one of three baud rates, defined in the Clock Rate register. When operating in Master mode, the hardware is multi-master capable, implementing both clock synchronization and arbitration. If the Slave Enable bit is not set, the block will operate in Master Only mode. All external Start conditions are ignored (although the Bus Busy status bit will still keep track of bus activity). Block enable will be synchronized to the SYSCLK clock input (see “Timing Diagrams” on page 493).

Bit 0: Enable Slave. When the slave is enabled, the block generates an interrupt on any Start condition and an address byte that it receives, indicating the beginning of an I2C transfer. When operating as a slave, the block is clocked from an external master. Therefore, the block will work at any frequency up to the maximum defined by the currently selected clock rate. The internal clock is only used in Slave mode, to ensure that there is adequate setup time from data output to the next clock on the release of a slave stall. When the Enable Slave and Enable Master bits are both '0', the block is held in reset and all status is cleared. See [Figure 28-3](#) for a description of the interaction between the Master/Slave Enable bits. Block enable will be synchronized to the SYSCLK clock input (see “Timing Diagrams” on page 493).

Table 28-3. Enable Master/Slave Block Operation

Enable Master	Enable Slave	Block Operation
No	No	Disabled: The block is disconnected from the GPIO pins, P1[5] and P1[7]. (The pins may be used as general purpose IO.) When either the master or slave is enabled, the GPIO pins are under control of the I2C hardware and are unavailable. All internal registers (except I2C_CFG) are held in reset.
No	Yes	Slave Only Mode: Any external Start condition will cause the block to start receiving an address byte. Regardless of the current state, any Start resets the interface and initiates a Receive operation. Any Stop will cause the block to revert to an idle state The I2C_MSCR register is held in reset.
Yes	No	Master Only Mode: External Start conditions are ignored in this mode. No Byte Complete interrupts on external traffic are generated, but the Bus Busy status bit continues to capture Start and Stop status, and thus may be polled by the master to determine if the bus is available. Full multi-master capability is enabled, including clock synchronization and arbitration. The block will generate a clock based on the setting in the Clock Rate register
Yes	Yes	Master/Slave Mode: Both master and slave may be operational in this mode. The block may be addressed as a slave, but firmware may also initiate Master mode transfers. In this configuration, when a master loses arbitration during an address byte, the hardware will revert to Slave mode and the received byte will generate a slave address interrupt.

For additional information, refer to the [I2C_CFG register](#) on page 224.

28.3.2 I2C_SCR Register

Address	Name	Bit 7	Bit 6	Bit 5	Bit 4	Bit 3	Bit 2	Bit 1	Bit 0	Access
0,D7h	I2C_SCR	Bus Error	Lost Arb	Stop Status	ACK	Address	Transmit	LRB	Byte Complete	# : 00

LEGEND

Access is bit specific. Refer to Table 28-4 for detailed bit descriptions.

The I2C Status and Control Register (I2C_SCR) is used by both master and slave to control the flow of data bytes and to keep track of the bus state during a transfer.

This register contains status bits, for determining the state of the current I2C transfer, and control bits, for determining the actions for the next byte transfer. At the end of each byte transfer, the I2C hardware interrupts the M8C microcontroller and stalls the I2C bus on the subsequent low of the clock, until the PSoC device intervenes with the next command. This register may be read as many times as necessary; but on a subsequent write to this register, the bus stall is released and the current transfer will continue.

There are six status bits: Byte Complete, LRB, Address, Stop Status, Lost Arb, and Bus Error. These bits have Read/Clear (R/C) access, which means that they are set by hardware but may be cleared by a write of '0' to the bit position. Under certain conditions, status is cleared automatically by the hardware. These cases are noted in Table 28-4.

There are two control bits: Transmit and ACK. These bits have RW access and may be cleared by hardware.

Bit 7: Bus Error. The Bus Error status detects misplaced Start or Stop conditions on the bus. These may be due to noise, rogue devices, or other devices that are not yet synchronized with the I2C bus traffic. According to the I2C specification, all compatible devices must reset their interface on a received Start or Stop. This is a natural thing to do in Slave mode, because a Start will initiate an address reception and a Stop will idle the slave. In the case of a master, this event will force the master to release the bus and idle. However, since a master does not respond to external Start or Stop conditions, an immediate interrupt on this event allows the master to continue to keep track of the bus state.

A bus error is defined as follows. A Start is only valid if the block is idle (master or slave) or a Slave receiver is ready to receive the first bit of a new byte after an ACK. Any other timing for a Start condition causes the Bus Error bit to be set. A Stop is only valid if the block is idle or a Slave receiver is ready to receive the first bit of a new byte after an ACK. Any other timing for a Stop condition causes the Bus Error bit to be set.

Table 28-4. I2C_SCR Status and Control Register

Bit	Access	Description	Mode
7	RC	Bus Error 1 = A misplaced Start or Stop condition was detected. This status bit must be cleared by firmware with a write of '0' to the bit position. It is never cleared by the hardware.	Master Only
6	RC	Lost Arb 1 = Lost Arbitration. This bit is set immediately on lost arbitration; however, it does not cause an interrupt. This status may be checked after the following Byte Complete interrupt. Any Start detect will automatically clear this bit.	Master Only
5	RC	Stop Status 1 = A Stop condition was detected. This status bit must be cleared by firmware with a write of '0' to the bit position. It is never cleared by the hardware.	Master/Slave
4	RW	ACK: Acknowledge Out 0 = NACK the last received byte. 1 = ACK the last received byte. This bit is automatically cleared by hardware on the following Byte Complete event.	Master/Slave
3	RC	Address 1 = The transmitted or received byte is an address. This status bit must be cleared by firmware with a write of '0' to the bit position.	Master/Slave
2	RW	Transmit 0 = Receive Mode. 1 = Transmit Mode. This bit is set by firmware to define the direction of the byte transfer. Any Start detect will automatically clear this bit.	Master/Slave
1	RC	LRB: Last Received Bit The value of the ninth bit in a Transmit sequence, which is the acknowledge bit from the receiver. 0 = Last transmitted byte was ACK'ed by the receiver. 1 = Last transmitted byte was NACK'ed by the receiver. Any Start detect will automatically clear this bit.	Master/Slave
0	RC	Byte Complete Transmit Mode: 1 = 8 bits of data have been transmitted and an ACK or NACK has been received. Receive Mode: 1 = 8 bits of data have been received. Any Start detect will automatically clear this bit.	Master/Slave

Bit 6: Lost Arb. This bit is set when I2C bus contention is detected, during a Master mode transfer. Contention will occur when a master is writing a '1' to the SDA output line and reading back a '0' on the SDA input line at the given sampling point. When this occurs, the block immediately releases the SDA, but continues clocking to the end of the current byte. On the resulting byte interrupt, firmware can determine that arbitration was lost to another master by reading this bit.

The sequence occurs differently between Master transmitter and Master receiver. As a transmitter, the contention will occur on a data bit. On the subsequent Byte Complete interrupt, the Lost Arbitration status is set. In Receiver mode, the contention will occur on the ACK bit. The master that NACK'ed the last reception will lose the arbitration. However, the hardware will shift in the next byte in response to the winning master's ACK, so that a subsequent Byte Complete interrupt occurs. At this point, the losing master can read the Lost Arbitration status. Contention is checked only at the eight data bit sampling points and one ACK bit sampling point.

Bit 5: Stop Status. Stop status is set on detection of an I2C Stop condition. This bit is sticky, which means that it will remain set until a '0' is written back to it by the firmware. This bit may only be cleared if the Byte Complete status is set. If the Stop Interrupt Enable bit is set, an interrupt is also generated on Stop detection. It is never automatically cleared.

Using this bit, a slave can distinguish between a previous Stop or Restart on a given address byte interrupt. In Master mode, this bit may be used in conjunction with the Stop IE bit, to generate an interrupt when the bus is free. However, in this case, the bit must have previously been cleared prior to the reception of the Stop in order to cause an interrupt.

Bit 4: ACK. This control bit defines the acknowledge data bit that is transmitted out in response to a received byte. When receiving, a Byte Complete interrupt is generated after the eighth data bit is received. On the subsequent write to this register to continue (or terminate) the transfer, the state of this bit will determine the next bit of data that is transmitted. It is **active high**. A '1' will send an ACK and a '0' will send a NACK.

A Master receiver normally terminates a transfer, by writing a '0' (NACK) to this bit. This releases the bus and automatically generates a Stop condition. A Slave receiver may also send a NACK, to inform the master that it cannot receive any more bytes.

Bit 3: Address. This bit is set when an address has been received. This consists of a Start or Restart, and an address byte. This bit applies to both master and slave.

In Slave mode, when this status is set, firmware will read the received address from the data register and compare it with its own address. If the address does not match, the firmware will write a NACK indication to this register. No further interrupts will occur, until the next address is received. If the address does match, firmware must ACK the received byte, then Byte Complete interrupts are generated on subsequent bytes of the transfer.

This bit will also be set when address transmission is complete in Master mode. If a lost arbitration occurs during the transmission of a master address (indicated by the Lost Arb bit), the block will revert to Slave mode if enabled. This bit then signifies that the block is being addressed as a slave.

If Slave mode is not enabled, the Byte Complete interrupt will still occur to inform the master of lost arbitration.

Bit 2: Transmit. This bit sets the direction of the shifter for a subsequent byte transfer. The shifter is always shifting in data from the I2C bus, but a write of '1' enables the output of the shifter to drive the SDA output line. Since a write to this register initiates the next transfer, data must be written to the data register prior to writing this bit. In Receive mode, the previously received data must have been read from the data register before this write. In Slave mode, firmware derives this direction from the RW bit in the received slave address. In Master mode, the firmware decides on the direction and sets it accordingly.

This direction control is only valid for data transfers. The direction of address bytes is determined by the hardware, depending on the Master or Slave mode.

The Master transmitter terminates a transfer by writing a zero to the transmit bit. This releases the bus and automatically sends a Stop condition, or a Stop/Start or Restart, depending on the I2C_MSCR control bits.

Bit 1: LRB (Last Received Bit). This is the last received bit in response to a previously transmitted byte. In Transmit mode, the hardware will send a byte from the data register and clock in an acknowledge bit from the receiver. On the subsequent byte complete interrupt, firmware will check the value of this bit. A '0' is the ACK value and a '1' is a NACK value. The meaning of the LRB depends on the current operating mode.

Master Transmitter:

'0': ACK. The slave has accepted the previous byte. The master may send another byte by first writing the byte to the I2C_DR register and then setting the Transmit bit in the I2C_SCR register. Optionally, the master may clear the Transmit bit in the I2C_SCR register. This will automatically send a Stop. If the Start or Restart bits are set in the I2C_MSCR register, the Stop may be followed by a Start or Restart.

'1': NACK. The slave cannot accept any more bytes. A Stop is automatically generated by the hardware on the subsequent write to the I2C_SCR register (regardless of the value written). However, a Stop/Start or Restart condition may also be generated, depending on whether firmware has set the Start or Restart bits in the I2C_MSCR register.

Slave Transmitter:

'0': ACK. The master wants to read another byte. The slave should load the next byte into the I2C_DR register and set the transmit bit in the I2C_SCR register to continue the transfer.

'1': NACK. The master is done reading bytes. The slave will revert to IDLE state on the subsequent I2C_SCR write (regardless of the value written).

Bit 0: Byte Complete. The I2C hardware operates on a byte basis. In Transmit mode, this bit is set and an interrupt is generated at the end of nine bits (the transmitted byte + the received ACK). In Receive mode, the bit is set after the eight bits of data are received. When this bit is set, an interrupt is generated at these data sampling points, which are associated with the SCL input clock rising (see details in the Timing section). If the PSoC device responds with a write back to this register before the subsequent falling edge of SCL (which is approximately one-half bit time), the transfer will continue without interruption. However, if the PSoC device is unable to respond within that time, the hardware will hold the SCL line low, stalling the I2C bus. In both Master and Slave mode, a subsequent write to the I2C_SCR register will release the stall.

For additional information, refer to the [I2C_SCR register on page 225](#).

28.3.3 I2C_DR Register

Address	Name	Bit 7	Bit 6	Bit 5	Bit 4	Bit 3	Bit 2	Bit 1	Bit 0	Access
0,D8h	I2C_DR	Data[7:0]								RW : 00

The I2C Data Register (I2C_DR) provides read/write access to the Shift register.

Bits 7 to 0: Data[7:0]. This register is not buffered; and therefore, writes and valid data reads may only occur at specific points in the transfer. These cases are outlined as follows.

- **Master or Slave Receiver** – Data in the I2C_DR register is only valid for reading, when the Byte Complete status bit is set. Data bytes must be read from the register before writing to the I2C_SCR register, which continues the transfer.

- **Master Start or Restart** – Address bytes must be written in I2C_DR before the Start or Restart bit is set in the I2C_MSCR register, which causes the Start or Restart to generate and the address to shift out.
- **Master or Slave Transmitter** – Data bytes must be written to the I2C_DR register before the transmit bit is set in the I2C_SCR register, which causes the transfer to continue.

For additional information, refer to the [I2C_DR register on page 227](#).

28.3.4 I2C_MSCR Register

Address	Name	Bit 7	Bit 6	Bit 5	Bit 4	Bit 3	Bit 2	Bit 1	Bit 0	Access
0,D9h	I2C_MSCR					Bus Busy	Master Mode	Restart Gen	Start Gen	R : 00

The I2C Master Status and Control Register (I2C_MSCR) implements I2C framing controls and provides Bus Busy status.

Bit 3: Bus Busy. This read only bit is set to '1' by any Start condition and reset to '0' by a Stop condition. It may be polled by firmware to determine when a bus transfer may be initiated.

Bit 2: Master Mode. This bit indicates that the device is operating as a master. It is set in the detection of this block's Start condition and reset in the detection of the subsequent Stop condition.

Bit 1: Restart Gen. This bit is only used at the end of a master transfer (as noted in Other Cases 1 and 2 of the Start Gen bit). If an address is loaded into the data register and this bit is set prior to NACKing (Master receiver) or resetting the transmit bit (Master transmitter), or after a Master transmitter is NACK'ed by the slave, a Restart condition is generated followed by the transmission of the address byte.

Bit 0: Start Gen. Before setting this bit, firmware must write the address byte to send into the I2C_DR register. When this bit is set, the Start condition is generated followed immediately by the transmission of the address byte. (No control in the I2C_SCR register is needed for the master to initiate a transmission; the direction is inherently "transmit.") The bit is automatically reset to '0' after the Start has been generated.

There are three possible outcomes as a result of setting the Start Gen bit.

1. The bus is free and the Start condition is generated successfully. A Byte Complete interrupt is generated after the Start and the address byte are transmitted. If the address was ACK'ed by the receiver, the firmware may then proceed to send data bytes.

2. The Start command is too late. Another master in a multi-master environment has generated a valid Start and the bus is busy. The resulting behavior depends upon whether Slave mode is enabled.

Slave mode is enabled: A Start and address byte interrupt is generated. When reading the I2C_MSCR register, the master will see that the Start Gen bit is still set and that the I2C_SCR register has the Address bit set, indicating that the block is addressed as a slave.

Slave mode is not enabled: The Start Gen bit will remain set and the Start is queued, until the bus becomes free and the Start condition is subsequently generated. An interrupt is generated at a later time, when the Start and address byte has been transmitted.

3. The Start is generated, but the master loses arbitration to another master in a multi-master environment. The resulting behavior depends upon whether Slave mode is enabled.

Slave mode is enabled: A Start and address byte interrupt is generated. When reading the I2C_MSCR, the master will see that the Start Gen bit cleared, indicating that the Start was generated. However, the Lost Arb bit is set in the I2C_SCR register. The Address status is also set, indicating that the block has been addressed as a slave. The firmware may then ACK or NACK the address to continue the transfer.

Slave mode is not enabled: A Start and address byte interrupt is generated. The Start Gen bit is cleared and the Lost Arb bit is set. The hardware will wait for command input, stalling the bus if necessary. In this case, the master will clear the I2C_SCR register, to release the bus and allow the transfer to continue, and the block will idle.

Other cases where the Start bit may be used to generate a Start condition are as follows.

1. When a master is finished with a transfer, a NACK is written to the I2C_SCR register (in the case of the Master receiver) or the transmit bit is cleared (in case of a Master transmitter). Normally, the action will free the stall and generate a Stop condition. However, if the Start bit is set and an address is written into the data register prior to the I2C_SCR write, a Stop, followed immediately by a Start (minimum bus free time), is generated. In this way, messages may be chained.

2. When a Master transmitter is NAK'ed, an automatic Stop condition is generated on the subsequent I2C_SCR write. However, if the Start Gen bit has previously been set, the Stop is immediately followed by a Start condition.

Table 28-5. I2C_MSCR Master Status/Control Register

Bit	Access	Description	Mode
3	R	Bus Busy This bit is set to '1' when any Start condition is detected and reset to '0' when a Stop condition is detected.	Master Only
2	R	Master Mode This bit is set to '1' when a start condition, generated by this block, is detected and reset to '0' when a stop condition is detected.	Master Only
1	RW	Restart Gen 1 = Generate a Restart condition. This bit is cleared by hardware when the Start generation is complete.	Master Only
0	RW	Start Gen 1 = Generate a Start condition and send a byte (address) to the I2C bus. This bit is cleared by hardware when the Start generation is complete.	Master Only

For additional information, refer to the [I2C_MSCR register](#) on page 228.

28.4 Timing Diagrams

28.4.1 Clock Generation

Figure 28-4 illustrates the I2C input clocking scheme. The SYSCLK pin is an input into a four-stage ripple divider that provides the baud rate selections. When the block is disabled, all internal state is held in a reset state. When either the Master or Slave Enable bits in the I2C_CFG register are set, the reset is synchronously released and the clock generation is enabled. Two taps from the **ripple divider** are selectable ($/4$, $/16$) from the clock rate bits in the I2C_CFG register. If any of the two divider taps is selected, that clock is resynchronized to SYSCLK. The resulting clock is routed to all of the synchronous elements in the design.

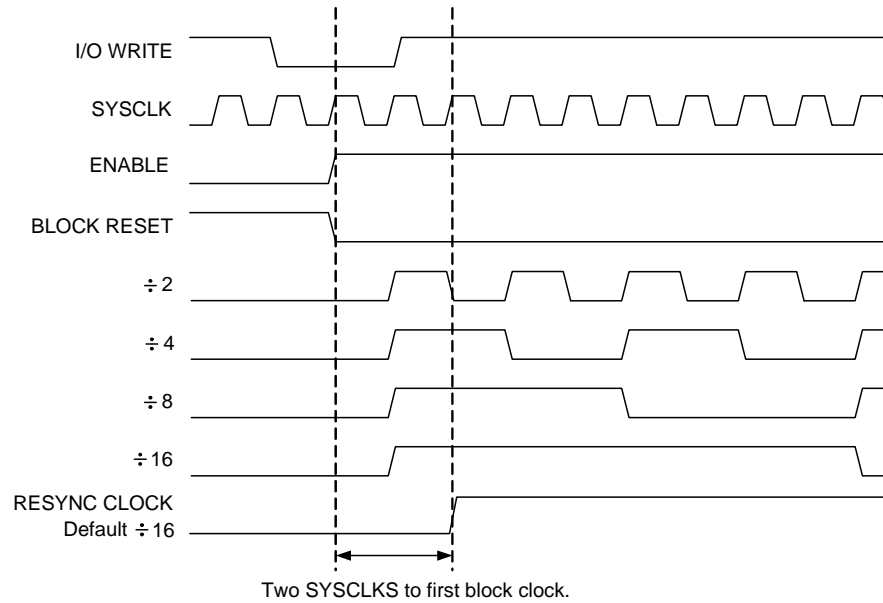

Figure 28-4. I²C Input Clocking

28.4.2 Basic Input/Output Timing

Figure 28-5 illustrates basic input output timing that is valid for both 16 times sampling and 32 times sampling. For 16 times sampling, $N=4$; and for 32 times sampling, $N=12$. N is derived from the half-bit rate sampling of eight and 16 clocks, respectively, minus the input latency of three (count of 4 and 12 correspond to 5 and 13 clocks).

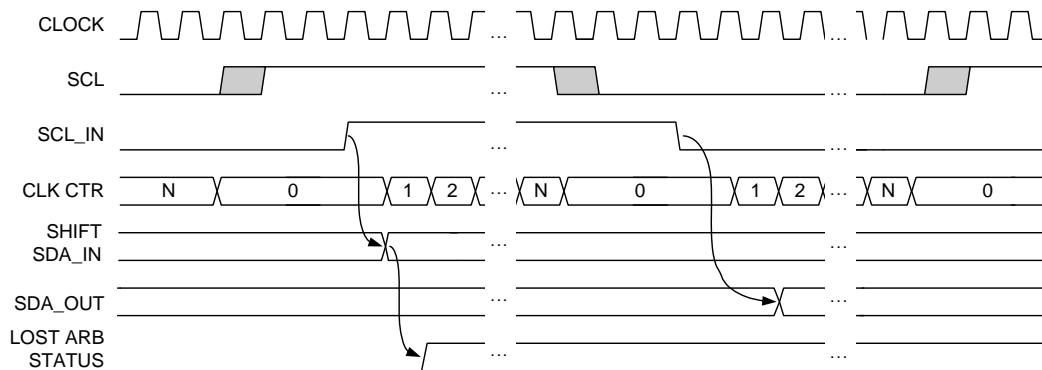

Figure 28-5. Basic Input/Output Timing

28.4.3 Status Timing

Figure 28-6 illustrates the interrupt timing for Byte Complete, which occurs on the positive edge of the ninth clock (byte + ACK/NACK) in Transmit mode and on the positive edge of the eighth clock in Receive mode. There is a maximum of three cycles of latency, due to the input synchronizer/filter circuit. As shown, the interrupt occurs on the clock following a valid SCL positive edge input transition (after the synchronizers). The Address bit is set with the same timing, but only after a slave address has been received. The LRB (Last Received Bit) status is also set with the same timing, but only on the ninth bit after a transmitted byte.

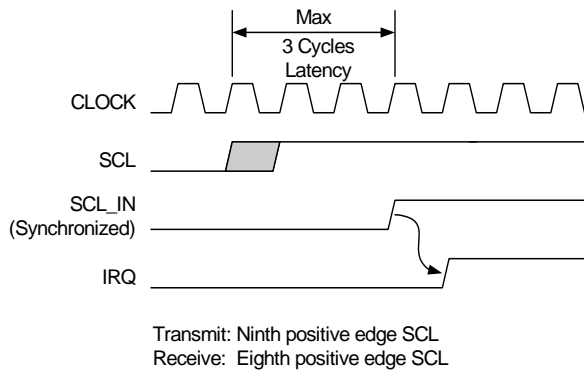

Figure 28-6. Byte Complete, Address, LRB Timing

Figure 28-7 shows the timing for Stop Status. This bit is set (and the interrupt occurs) two clocks after the synchronized and filtered SDA line transitions to a '1', when the SCL line is high.

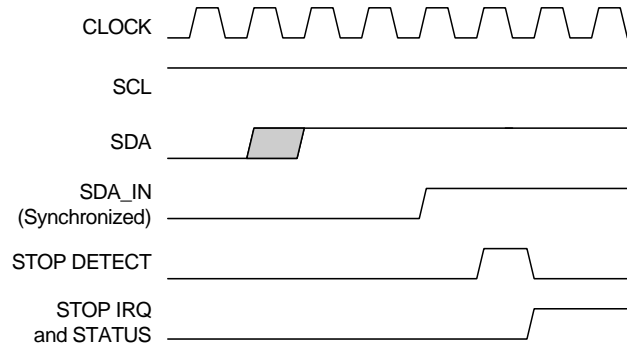

Figure 28-7. Stop Status and Interrupt Timing

Figure 28-8 illustrates the timing for bus error interrupts. Bus Error status (and Interrupt) occurs one cycle after the internal Start or Stop Detect (two cycles after the filtered and synced SDA input transition).

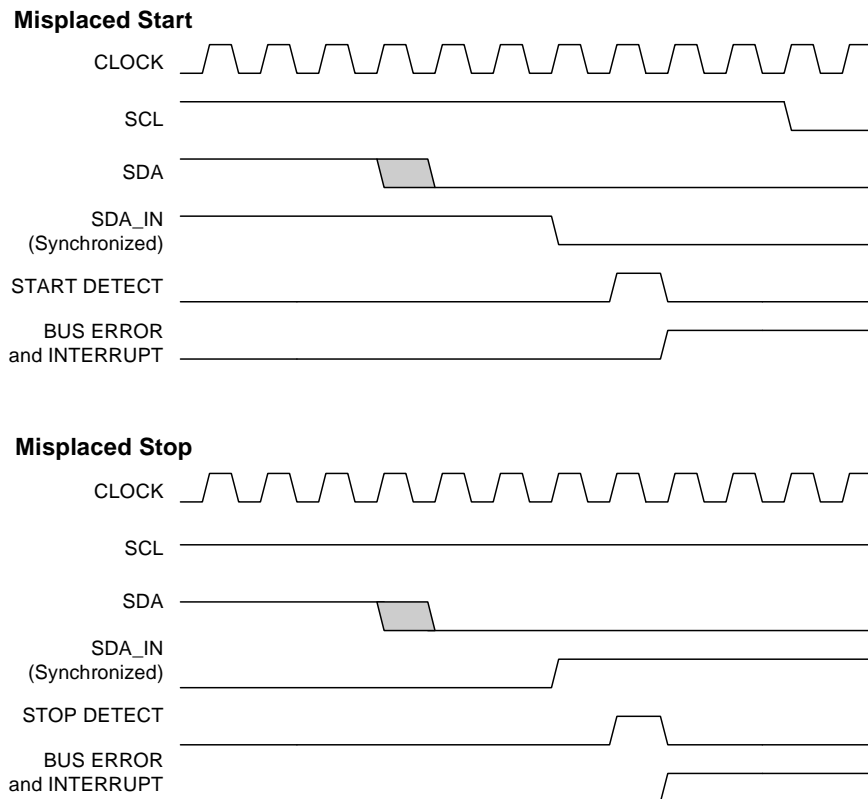

Figure 28-8. Bus Error Interrupt Timing

28.4.4 Master Start Timing

When firmware writes the Start Gen command, hardware resynchronizes this bit to SYSCLK, to ensure a minimum of a full SYSCLK of setup time to the next clock edge. When the Start is initiated, the SCL line is left high for 6/14 clocks (corresponding to 16/32 times sampling rates). During this initial SCL high period, if an external Start is detected, the Start sequence is aborted and the block returns to an IDLE state. However, on the next Stop detection, the block will automatically initiate a new Start sequence.

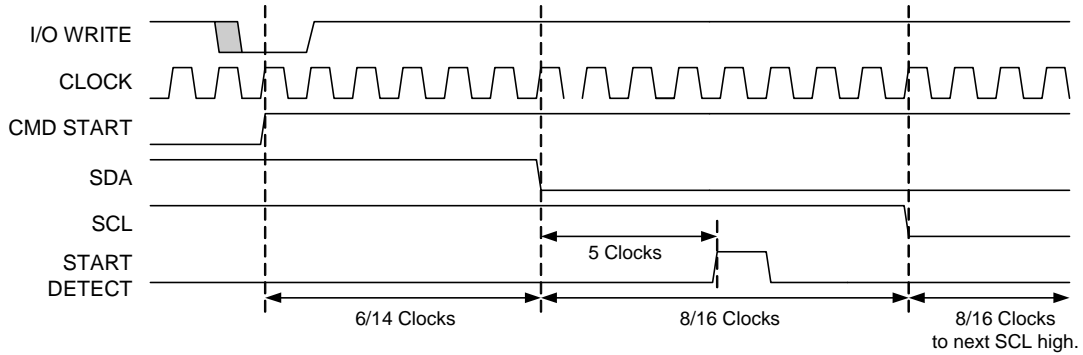

Figure 28-9. Basic Master Start Timing

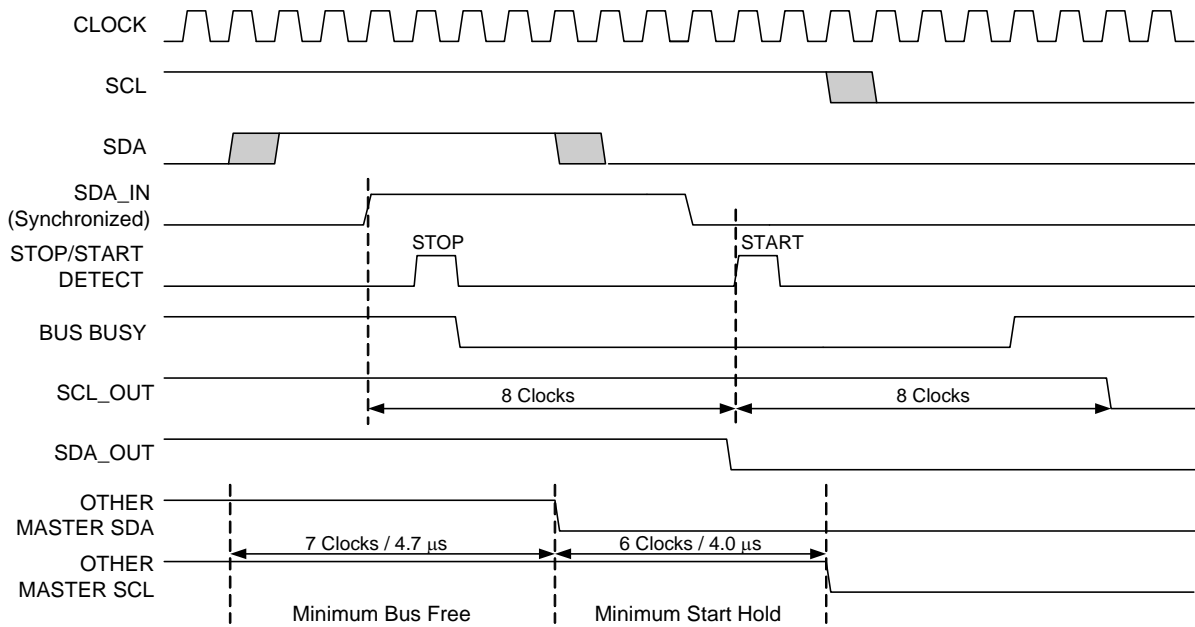

Figure 28-10. Start Timing with a Pending Start

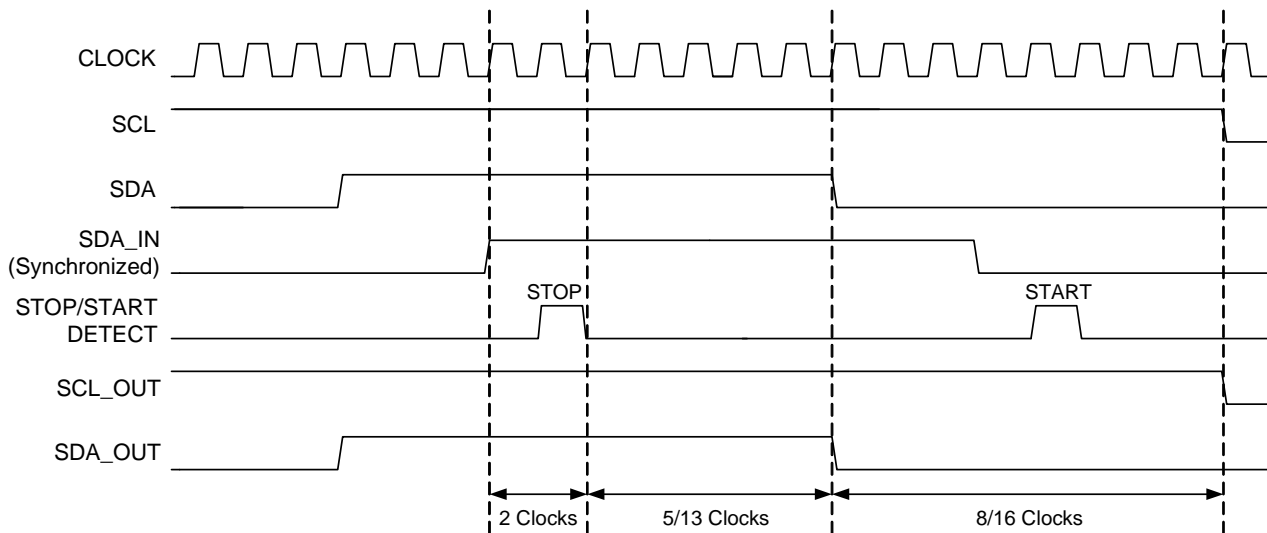

Figure 28-11. Master Stop/Start Chaining

28.4.5 Master Restart Timing

Figure 28-12 shows the Master Restart timing. After the ACK/NACK bit, the clock is held low for a half bit time ($8/16$ clocks corresponding to the 16 or 32 times sampling rates), during which time the data is allowed to go high, then a valid start is generated in the following 3 half bit times as shown.

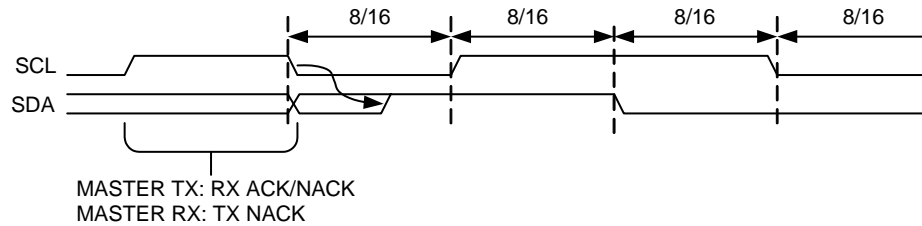

Figure 28-12. Master Restart Timing

28.4.6 Master Stop Timing

Figure 28-13 shows basic Master Stop timing. In order to generate a Stop, the SDA line is first pulled low, in accordance with the basic SDA output timing. Then, after the full low of SCL is completed and the SCL line is pulled high, the SDA line remains low for a full one-half bit time before it is pulled high to signal the Stop.

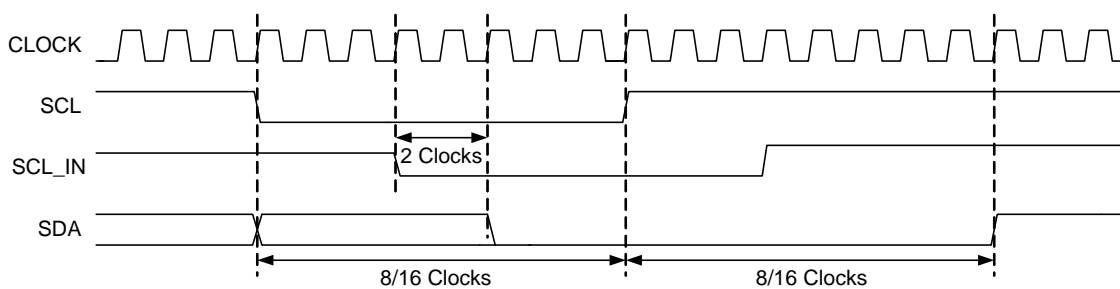

Figure 28-13. Master Stop Timing

28.4.7 Master/Slave Stall Timing

When a Byte Complete interrupt occurs, the PSoC device firmware must respond with a write to the I2C_SCR register to continue the transfer (or terminate the transfer). The interrupt occurs two clocks after the rising edge of SCL_IN (see “Status Timing” on page 494). As illustrated in Figure 28-14, firmware has until one clock after the falling edge of SCL_IN to write to the I2C_SCR register; otherwise, a stall occurs. Once stalled, the IO write releases the stall. The setup time between data output and the next rising edge of SCL will always be N-1 clocks.

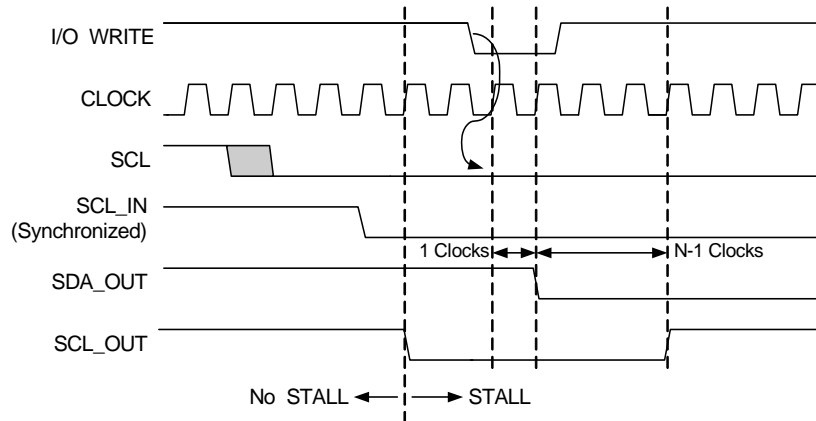

Figure 28-14. Master/Slave Stall Timing

28.4.8 Master Lost Arbitration Timing

Figure 28-15 shows a Lost Arbitration sequence. When contention is detected at the input (SDA_IN) sampling point, the SDA output is immediately released to an IDLE state. However, the master continues clocking until the Byte Complete interrupt, which is processed in the usual way. Any write to the I2C_SCR register results in the master reverting to an IDLE state, one clock after the next positive edge of the SCL_IN clock.

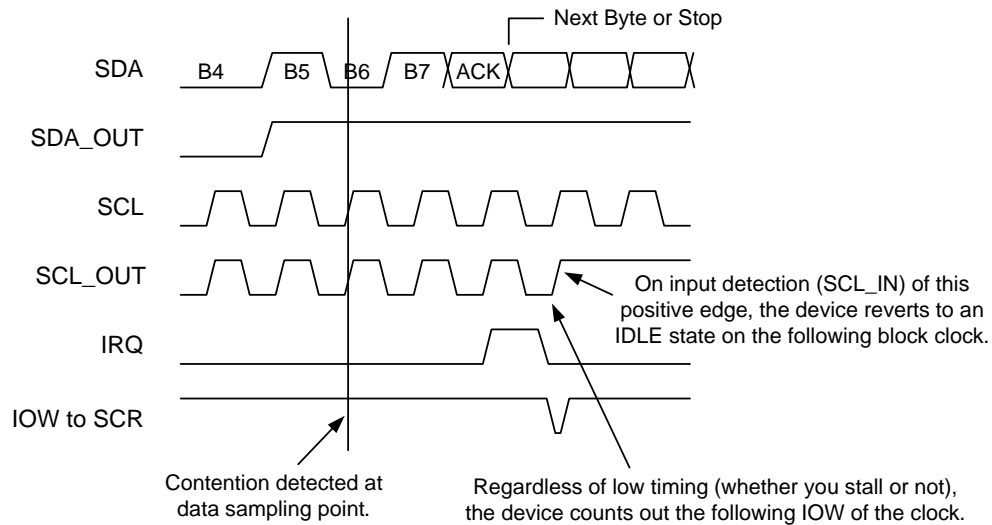

Figure 28-15. Lost Arbitration Timing (Transmitting Address or Data)

28.4.9 Master Clock Synchronization

Figure 28-16 shows the timing associated with Master Clock Synchronization. Clock synchronization is always operational, even if it is the only master on the bus. In which case, it is synchronizing to its own clock. In the wired AND bus, an SCL output of '0' is seen by all masters. When the hardware asserts a '0' to the output, it is immediately fed back from the PSoC device pin to the input synchronizer for the SCL input. The counter value (depending on the sampling rate) takes into account the worst case latency for input synchronization of three clocks, giving a net period of $8/16$ clocks for both high and low time. This results in an overall clocking rate of $16/32$ clocks per bit.

In multi-master environments when the hardware outputs a '1' on the SCL output, if any other master is still asserting a '0', the clock counter will hold until the SCL input line matches the '1' on the SCL output line. When matched, the remainder of the high time is counted down. In this way, the master with the fastest frequency determines the high time of the clock and the master with the lowest frequency determines the low time of the clock.

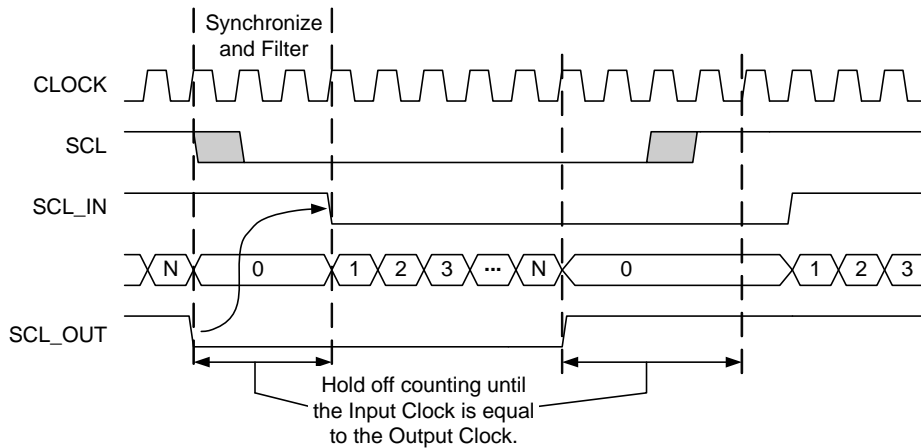

Figure 28-16. Master Clock Synchronization

29. Internal Voltage Reference



This chapter discusses the Internal Voltage Reference and its associated register. The internal voltage reference provides an absolute value of 1.3V to a variety of subsystems in the PSoC device. For a quick reference of all PSoC registers in address order, refer to the [Register Details](#) chapter on page 147.

29.1 Architectural Description

The Internal Voltage Reference is made up of two blocks: a bandgap voltage generator and a buffer with sample and hold. The bandgap voltage generator is a typical $(V_{BE} + K V_T)$ design.

The buffer circuit provides gain to the 1.20V bandgap voltage, to produce a 1.30V reference. A simplified **schematic** is illustrated in [Figure 29-1](#). The connection between amplifier and capacitor is made through a CMOS switch, allowing the reference voltage to be used by the system while the reference circuit is powered down. The voltage reference is trimmed to 1.30V at room temperature.

A temperature proportional voltage is also produced in this block for use in temperature sensing.

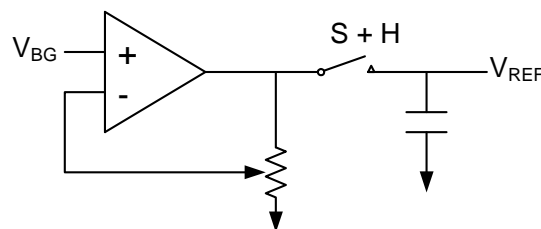

Figure 29-1. Voltage Reference Schematic

29.2 PSoC Device Distinctions

The internal voltage reference register, BDG_TR, is a read and write register with one exception: The CY8C27x43 PSoC device cannot read the BDG_TR register.

29.3 Register Definitions

The following register is associated with the Internal Voltage Reference. The Internal Voltage Reference is trimmed for gain and temperature coefficient using the BDG_TR register. The register description below has an associated register table showing the bit structure. The bits that are grayed out in the table are reserved bits and are not detailed in the register description that follows. Reserved bits should always be written with a value of '0'.

29.3.1 BDG_TR Register

Addr.	Name	Cols.	Bit 7	Bit 6	Bit 5	Bit 4	Bit 3	Bit 2	Bit 1	Bit 0	Access
1,EAh	BDG_TR	4, 2		AGNDBYP	TC[1:0]		V[3:0]			RW : 00	
		1			TC[1:0]		V[3:0]				

NOTE

The CY8C27x43 PSoC device cannot read this register.

The Bandgap Trim Register (BDG_TR) is used to adjust the bandgap and add an RC filter to AGND.

Depending on how many analog columns your PSoC device has (see the Cols. column in the register table above), only certain bits are accessible to be read or written (refer to the table titled "PSoC Device Characteristics" on page 22).

Bit 6: AGNDBYP. When set, this bit adds an RC filter to AGND. (R is an internal 8.1K resistor and C is external to the PSoC device on P2[4].)

Bits 5 and 4: TC[1:0]. These bits are for setting the temperature coefficient inside the bandgap voltage generator. 10b is the design center for '0' TC.

It is strongly recommended that the user not alter the value of these bits.

Bits 3 to 0: V[3:0]. These bits are for setting the gain in the reference buffer. Sixteen steps of 4 mV are available. 1000b is the design center for 1.30V.

It is strongly recommended that the user not alter the value of these bits.

For additional information, refer to the [BDG_TR register on page 300](#).

30. System Resets



This chapter discusses the System Resets and their associated registers. PSoC devices support several types of resets. The various resets are designed to provide error-free operation during power up for any voltage ramping profile, to allow for user-supplied external reset and to provide recovery from errant code operation. For a complete table of the System Reset registers, refer to the “[Summary Table of the System Resource Registers](#)” on page 455. For a quick reference of all PSoC registers in address order, refer to the [Register Details](#) chapter on page 147.

30.1 Architectural Description

When reset is initiated, all registers are restored to their default states. In the [Register Details](#) chapter on page 147, this is indicated by the POR column in the register tables and elsewhere it is indicated in the Access column, values on the right side of the colon, in the register tables. Minor exceptions are explained below.

The following types of resets can occur in the PSoC device:

- Power on Reset (POR). This occurs at low supply voltage and is comprised of multiple sources.
- External Reset (XRES). This active high reset is driven into the PSoC device, on parts that contain an XRES pin.
- Watchdog Reset (WDR). This optional reset occurs when the watchdog timer expires, before being cleared by user firmware. Watchdog reset defaults to off.
- Internal Reset (IRES). This occurs during the boot sequence, if the SROM code determines that Flash reads are not valid.

The occurrence of a reset is recorded in the Status and Control registers (CPU_SCR0 for POR, XRES, and WDR) or in the System Status and Control Register 1 (CPU_SCR1 for IRESS). Firmware can interrogate these registers to determine the cause of a reset.

30.2 Pin Behavior During Reset

Power on Reset and External Reset cause toggling on two GPIO pins, P1[0] and P1[1], as described below and illustrated in [Figure 30-1](#) and [Figure 30-2](#). This allows programmers to synchronize with the PSoC device. All other GPIO pins are placed in a high impedance state during and immediately following reset.

30.2.1 GPIO Behavior on Power Up

At power up, the internal POR causes P1[0] to initially drive a strong high (1) while P1[1] drives a resistive low (0). After 256 sleep oscillator cycles, the P1[0] signal transitions to a resistive low state. After additional 256 sleep oscillator clocks, both pins transition to a high impedance state and normal CPU operation begins. This is illustrated in [Figure 30-1](#).

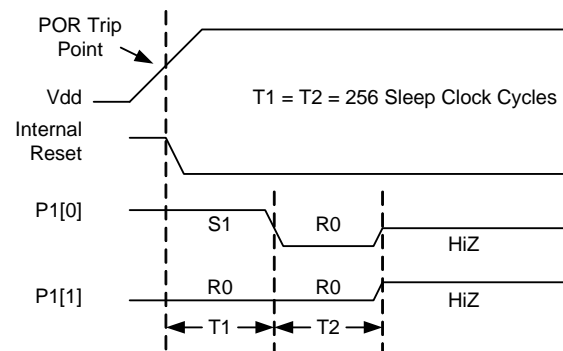

Figure 30-1. P1[1:0] Behavior on Power Up

30.2.2 GPIO Behavior on External Reset

During External Reset ($XRES=1$), both P1[0] and P1[1] drive resistive low (0). After XRES deasserts, these pins continue to drive resistive low for another 8 sleep clock cycles. After this time, both pins transition to a high impedance state and normal CPU operation begins. This is illustrated in Figure 30-2.

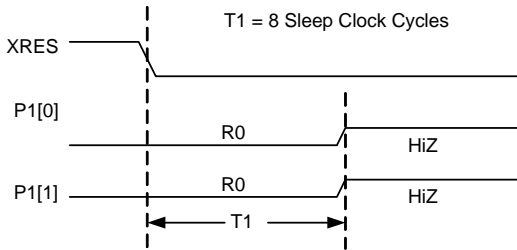

Figure 30-2. P1[1:0] Behavior on External Reset (XRES)

30.3 Register Definitions

The following registers are associated with the PSoC System Resets and are listed in address order. Each register description has an associated register table showing the bit structure for that register. The bits in the tables that are grayed out are reserved bits and are not detailed in the register descriptions that follow. Reserved bits should always be written with a value of '0'. For a complete table of system reset registers, refer to the “Summary Table of the System Resource Registers” on page 455.

30.3.1 CPU_SCR1 Register

Address	Name	Bit 7	Bit 6	Bit 5	Bit 4	Bit 3	Bit 2	Bit 1	Bit 0	Access
x,FEh	CPU_SCR1	IRESS			SLIMO	ECO EXW *	ECO EX *		IRAMDIS	# : 00

LEGEND

x An “x” before the comma in the address field indicates that this register can be read or written to no matter what bank is used.

Access is bit specific. Refer to the [Register Details chapter on page 147](#) for additional information.

* Bits 3 and 2 (ECO EXW and ECO EX, respectively) cannot be used by the CY8C27x43 for silicon revision A, and by the CY8C24x23 and CY8C22x13 PSoC devices.

The System Status and Control Register 1 (CPU_SCR1) is used to convey the status and control of events related to internal resets and watchdog reset.

Bit 7: IRESS. The Internal Reset Status bit is a read only bit that may be used to determine if the booting process occurred more than once.

When this bit is set, it indicates that the SROM SWBootReset code was executed more than once. If this bit is not set, the SWBootReset was executed only once. In either case, the SWBootReset code will not allow execution from code stored in Flash until the M8C Core is in a safe operating mode with respect to supply voltage and Flash operation. There is no need for concern when this bit is set. It is provided for systems which may be sensitive to boot time, so that they can determine if the normal one-pass boot time was exceeded. For more information on the SWBootReset code see the [Supervisory ROM \(SROM\) chapter on page 73](#).

Bit 4: SLIMO. When set, the Slow IMO bit allows the active power dissipation of the PSoC device to be reduced by slowing down the IMO from 24 MHz to 6 MHz. The IMO trim value must also be changed when SLIMO is set (see “[Engaging Slow IMO \(SLIMO\)](#)” on page 114). When not in external clocking mode, the IMO is the source for SYSCLK; therefore, when the speed of the IMO changes, so will SYSCLK.

Bit 3: ECO EXW. The ECO Exists Written bit is used as a status bit to indicate that the ECO EX bit has been previ-

ously written to. It is read only. When this bit is a ‘1’, this indicates that the CPU_SCR1 register has been written to and is now locked. When this bit is a ‘0’, the register has not been written to since the last reset event. Note that this bit cannot be used by the CY8C27x43 for silicon revision A, and by the CY8C24x23 and CY8C22x13 PSoC devices.

Bit 2: ECO EX. The ECO Exists bit serves as a flag to the hardware, to indicate that an external crystal **oscillator** exists in the system. Just after boot, it may be written *only once* to a value of ‘1’ (crystal exists) or ‘0’ (crystal does not exist). If the bit is ‘0’, a switch-over to the ECO is locked out by hardware. If the bit is ‘1’, hardware allows the firmware to freely switch between the ECO and ILO. It should be written as early as possible after a **Power On Reset (POR)** or **External Reset (XRES)** event, where it is assumed that program execution integrity is high. Note that this bit cannot be used by the CY8C27x43 for silicon revision A, and by the CY8C24x23 and CY8C22x13 PSoC devices.

Bit 0: IRAMDIS. The Initialize RAM Disable bit is a control bit that is readable and writeable. The **default value** for this bit is ‘0’, which indicates that the maximum amount of SRAM should be initialized on watchdog reset to a value of 00h. When the bit is ‘1’, the minimum amount of SRAM is initialized after a watchdog reset. For more information on this bit, see the “[SROM Function Descriptions](#)” on page 74.

For additional information, refer to the [CPU_SCR1 register on page 251](#).

30.3.2 CPU_SCR0 Register

Address	Name	Bit 7	Bit 6	Bit 5	Bit 4	Bit 3	Bit 2	Bit 1	Bit 0	Access
0,FFh	CPU_SCR0	GIES		WDRS	PORS	Sleep			STOP	# : XX

LEGEND

Access is bit specific. Refer to register detail for additional information.
 XX The reset value is 10h after POR/XRES and 20h after a watchdog reset.

The System Status and Control Register 0 (CPU_SCR0) is used to convey the status and control of events for various functions of a PSoC device.

Bit 7: GIES. The Global Interrupt Enable Status bit is a read only status bit and its use is discouraged. The GIES bit is a legacy bit which was used to provide the ability to read the GIE bit of the CPU_F register. However, the CPU_F register is now readable. When this bit is set, it indicates that the GIE bit in the CPU_F register is also set which, in turn, indicates that the microprocessor will service interrupts.

Bit 5: WDRS. The WatchDog Reset Status bit may not be set. It is normally '0' and automatically set whenever a watchdog reset occurs. The bit is readable and clearable by writing a zero to its bit position in the CPU_SCR0 register.

Bit 4: PORS. The Power On Reset Status (PORS) bit, which is the watchdog enable bit, is set automatically by a POR or External Reset (XRES). If the bit is cleared by user code, the watchdog timer is enabled. Once cleared, the only way to reset the PORS bit is to go through a POR or XRES. Thus, there is no way to disable the watchdog timer, other than to go through a POR or XRES.

Bit 3: Sleep. The Sleep bit is used to enter Low Power Sleep mode when set. To wake up the system, this register bit is cleared asynchronously by any enabled interrupt. There are two special features of this register bit that ensures proper Sleep operation. First, the write to set the register bit is blocked, if an interrupt is about to be taken on that instruction boundary (immediately after the write). Second, there is a hardware interlock to ensure that, once set, the sleep bit may not be cleared by an incoming interrupt until the sleep circuit has finished performing the sleep sequence and the system-wide power down signal has been asserted. This prevents the sleep circuit from being interrupted in the middle of the process of system power down, possibly leaving the system in an indeterminate state.

Bit 0: STOP. The STOP bit is readable and writeable. When set, the PSoC M8C will stop executing code until a reset event occurs. This can be either a POR, WDR, or XRES. If an application wants to stop code execution until a reset, the preferred method would be to use the HALT instruction rather than a register write to this bit.

For additional information, refer to the [CPU_SCR0 register on page 252](#).

30.4 Timing Diagrams

30.4.1 Power On Reset

A Power on Reset (POR) is triggered whenever the supply voltage is below the POR trip point. POR ends once the supply voltage rises above this voltage. Refer to the [POR and LVD chapter on page 513](#) for more information on the operation of the POR block.

POR consists of two pieces: an imprecise POR (IPOR) and a Precision POR (PPOR). “POR” refers to the OR of these two functions. IPOR has coarser accuracy and its trip point is typically lower than PPOR’s trip point. PPOR is derived from a circuit that is calibrated (during boot), for a very accurate location of the POR trip point.

During POR (POR=1), the IMO is powered off for low power during start-up. Once POR deasserts, the IMO is started (see [Figure 30-4](#)).

POR configures register reset status bits as shown in [Table 30-1](#). PPOR does not affect the Bandgap Trim register (BDG_TR), but IPOR does reset this register.

30.4.2 External Reset

An External Reset (XRES) is caused by pulling the XRES pin high. The XRES pin has an always-on, pull down resistor, so it does not require an external pull down for operation and can be tied directly to ground or left open. Behavior after XRES is similar to POR.

During XRES (XRES=1), the IMO is powered off for low power during start-up. Once XRES deasserts, the IMO is started (see [Figure 30-4](#)). How the XRES configures register reset status bits is shown in [Table 30-1](#).

30.4.3 Watchdog Timer Reset

The user has the option to enable the Watchdog Timer Reset (WDR), by clearing the PORS bit in the CPU_SCR0 register. Once the PORS bit is cleared, the watchdog timer cannot be disabled. The only exception to this is if a POR/XRES event takes place, which will disable the WDR. Note that a WDR does not clear the Watchdog timer. See “[Watchdog Timer](#)” on [page 138](#) for details of the Watchdog operation.

When the watchdog timer expires, a watchdog event occurs resulting in the reset sequence. Some characteristics unique to the WDR are as follows.

- PSoC device reset asserts for one cycle of the CLK32K clock (at its reset state).
- The IMO is not halted during or after WDR (that is, the part does not go through a low power phase).
- CPU operation re-starts one CLK32K cycle after the internal reset deasserts (see [Figure 30-3](#)).

How the WDR configures register reset status bits is shown in [Table 30-1](#).

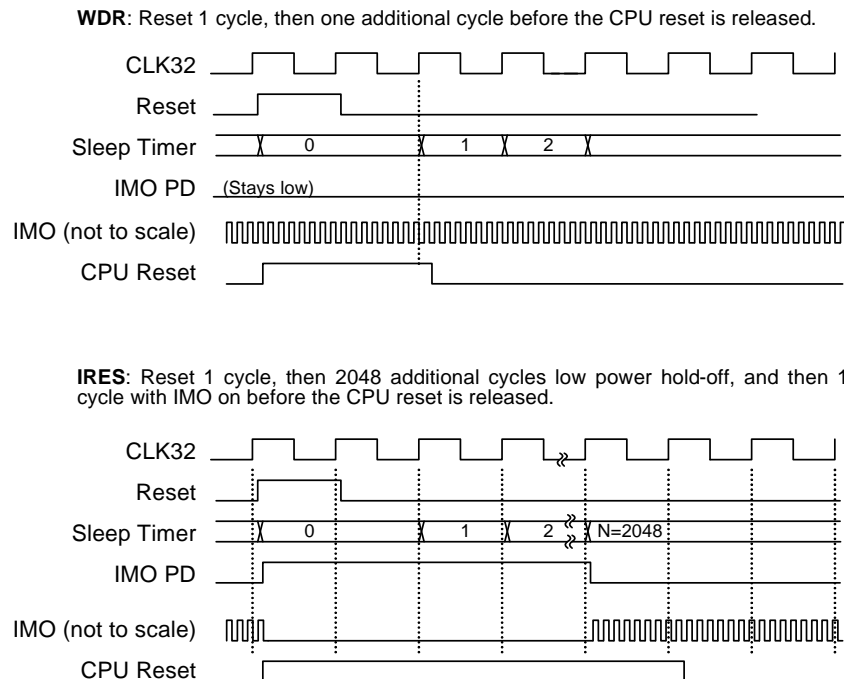
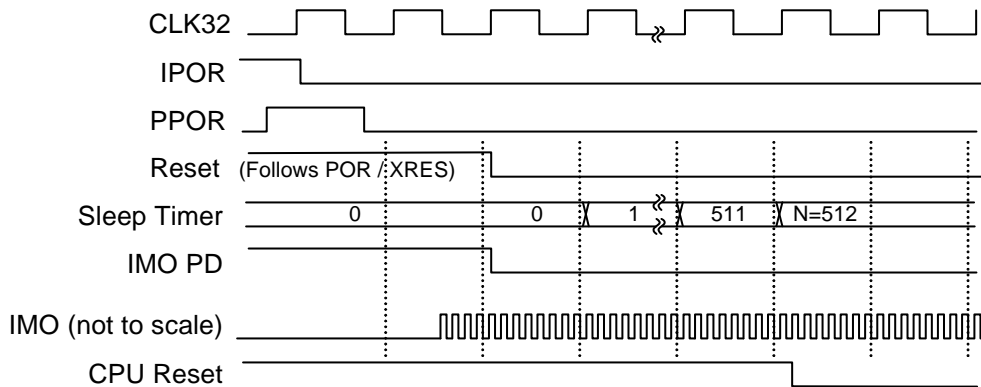
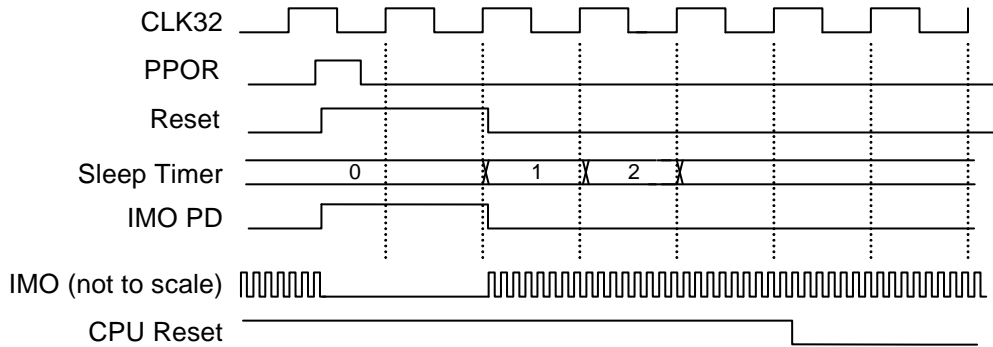

Figure 30-3. Key Signals During WDR and IRES

POR (IPOR followed by PPOR): Reset while POR is high (IMO off), then 511(+) cycles (IMO on), and then the CPU reset is released. **XRES** is the same, with N=8.



PPOR (with no IPOR): Reset while PPOR is high and to the end of the next 32K cycle (IMO off); 1 cycle IMO on before the CPU reset is released. Note that at the 5V level, PPOR will tend to be brief, because the reset clears the POR range register (VLT_CR) back to the default 3V setting.



XRES: Reset while XRES is high (IMO off), then 7(+) cycles (IMO on), and then the CPU reset is released.

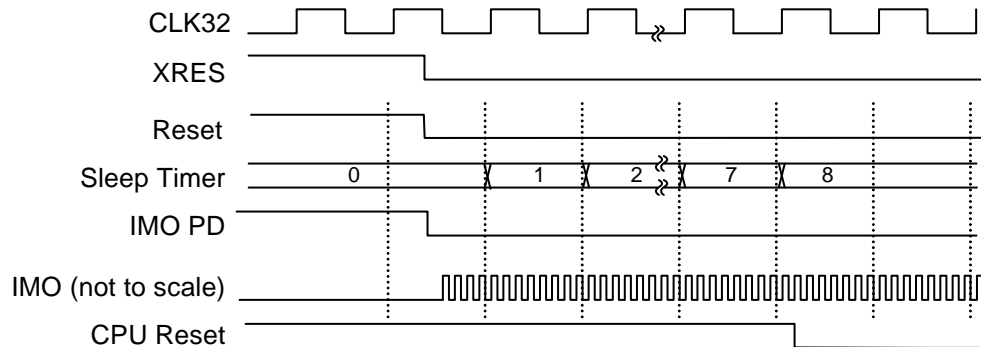

Figure 30-4. Key Signals During POR and XRES

30.4.4 Reset Details

Timing and functionality details are summarized in [Table 30-1](#). [Figure 30-4](#) shows some of the relevant signals for IPOR, PPOR, and XRES, while [Figure 30-3](#) shows signaling for WDR and IRES.

Table 30-1. Details of Functionality for Various Resets

Item	IPOR (Part of POR)	PPOR (Part of POR)	XRES	WDR
Reset Length	While POR=1	While PPOR=1, plus 30-60 μ s (1-2 clocks)	While XRES=1	30 μ s (1 clock)
Low Power (IMO Off) During Reset?	Yes	Yes	Yes	No
Low Power Wait Following Reset?	No	No	No	No
CLK32K Cycles from End of Reset to CPU Reset Deasserts ^a	512 ^b	1 ^b	8 ^b	1 ^b
Register Reset (See next line for CPU_SCR0, CPU_SCR1)	All	All, except PPOR does not reset Bandgap Trim register	All	All
Reset Status Bits in CPU_SCR0, CPU_SCR1	Set PORS, Clear WDRS, Clear IRAMDIS	Set PORS, Clear WDRS, Clear IRAMDIS	Set PORS, Clear WDRS, Clear IRAMDIS	Clear PORS, Set WDRS, IRAMDIS unchanged
Bandgap Power	On	On	On	On
Boot Time ^c	2.2 ms	2.2 ms	2.2 ms	2.2 ms

- CPU reset is released after synchronizing with the CPU Clock.
- The CLK32K clock source (the Internal Low speed Oscillator, ILO) is not trimmed at this point in the boot sequence. Use the F_{32KU} specification from the device data sheet to determine the slowest untrimmed ILO frequency and the maximum reset recovery time.
- Measured from CPU reset release to execution of the code at Flash address 0x0000.

30.5 Power Consumption

The ILO block drives the CLK32K clock used to time most events during the reset sequence. This clock is powered down by IPOR, but not by any other reset. The sleep timer provides interval timing.

While POR or XRES assert, the IMO is powered off to reduce start-up power consumption.

During and following IRES (for 64 ms nominally), the IMO is powered off for low average power during slow supply ramps.

During and after POR or XRES, the bandgap circuit is powered up.

Following IRES, the bandgap circuit is only powered up occasionally, to refresh the sampled bandgap voltage value. This sampling follows the same process used during sleep mode.

The IMO is always on for at least one CLK32K cycle, before CPU reset is deasserted.

31. Switch Mode Pump (SMP)



This chapter explains the Switch Mode Pump (SMP) and its associated register. Using only a few external components, the SMP will pump a battery voltage up to a configurable stable operating voltage. Refer to the table titled “PSoC Devices System Resource Availability” on page 454 for SMP availability by PSoC part number. For a quick reference of all PSoC registers in address order, refer to the Register Details chapter on page 147.

31.1 Architectural Description

The SMP circuit can be used to generate typical operating supply voltages off a single battery cell. During the time V_{dd} is ramping from 0V to V_{PPOR} (2.921V typical), **integrated circuit (IC)** operation is held off by the POR circuit and the SMP circuit is forced on. The pump is realized by connecting an external inductor between V_{BAT} and the SMP pin, with an external diode pointing from the SMP pin to the V_{dd} pin. A bypass capacitor of at least 0.1 μF must be connected between V_{dd} and V_{ss} . The inductor is charged when the internal SMP switch is on. When this switch is turned off, a Flyback mode occurs and the inductor energy is released into the bypass capacitor. This is done in a periodic fashion (1.3 MHz), charging the capacitor until the SMP is commanded to turn off by the PORBOUT circuit. V_{dd} is pumped to a voltage level specified in the Voltage Monitor Control register ($VLT_CR[2:0]$). The SMP supports V_{BAT} values down to 1.0V during operation, but a start-up is not guaranteed for battery voltages below 1.1V. Once the PSoC device is enabled after its power up and boot sequence, firmware can disable the SMP function by writing $VLT_CR[7]$ to a '1'.

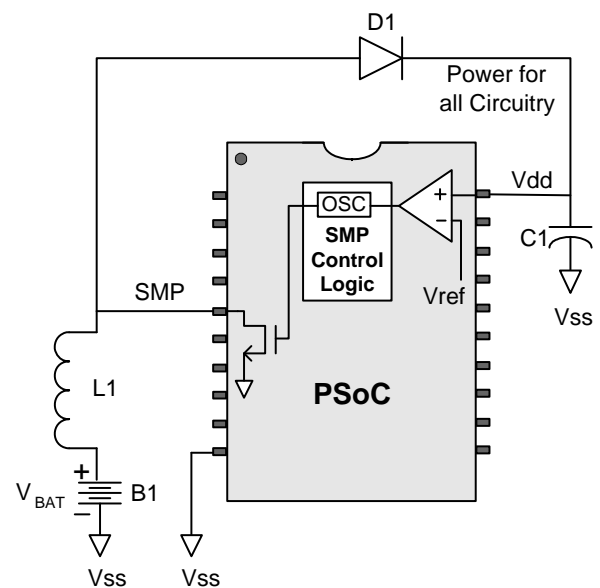

Figure 31-1. Example Switch Mode Pump for a 20-Pin PSoC Device

31.2 Application Description

When the PSoC device is put into Sleep mode, the SMP remains running to maintain voltage. This may result in higher than specification sleep current, depending upon the application. If the user desires, the pump may be disabled during precision measurements (such as analog-to-digital conversions) and then re-enabled (writing SMP bit 7 to '1' and then back to '0'). However, the user is responsible for making the operation happen quickly enough to guarantee supply holdup (by the bypass capacitor, C1) sufficient for continued operation.

31.2.1 Component Value Selection

This section discusses some general guidelines for selecting components for the SMP. For more information, refer to the PSoC Application Note 2097 on the web at <http://www.cypress.com/psoc>.

Inductor. The inductor value determines how much load current can be supplied by the SMP. Efficiency of the SMP is also affected by the inductor. In general, a larger inductor provides a higher efficiency. The following efficiency and load curves are based on silicon test results.

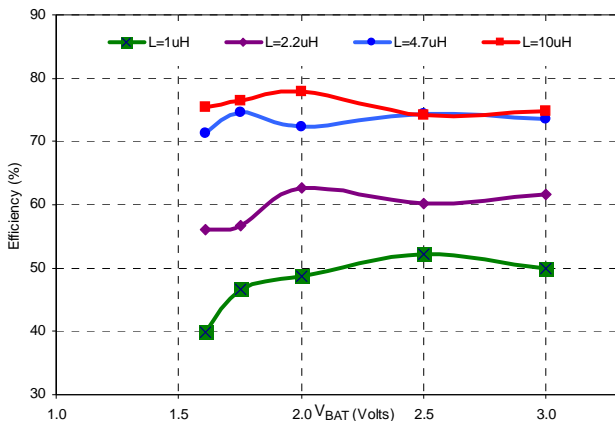

Figure 31-2. Typical Efficiency Values at Room Temperature

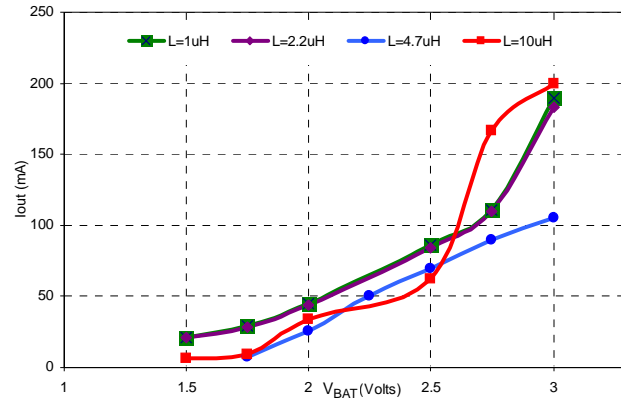

Figure 31-3. Typical Values of Maximum Load Current

Capacitor. The choice of capacitor at the V_{dd} node determines the ripple and hold time at the output voltage. A typical capacitor value is 10 μ F.

Diode. Schottky diodes are recommended because they have a low forward voltage drop and fast switching speed.

31.3 Register Definitions

The following register is associated with the Switch Mode Pump (SMP). To determine the availability of a SMP for your PSoC device, refer to the table on “[PSoC Devices System Resource Availability](#)” on page 454. Note that the CY8C22xxx does not have SMP functionality. The register description below has an associated register table showing the bit structure of the register. The bit in the table that is grayed out is a reserved bit and is not detailed in the register description below. Reserved bits should always be written with a value of ‘0’.

31.3.1 VLT_CR Register

Address	Name	Bit 7	Bit 6	Bit 5	Bit 4	Bit 3	Bit 2	Bit 1	Bit 0	Access
1,E3h	VLT_CR	SMP		PORLEV[1:0]		LVDTBEN	VM[2:0]			RW : 00

The Voltage Monitor Control Register (VLT_CR) is used to set the trip points for POR, LVD, and the supply pump.

The VLT_CR register is cleared by all resets, which can cause reset cycling during very slow supply ramps to 5V when the POR range is set for the 5V range. This is because the reset clears the POR range setting back to 3V and a new boot/start-up occurs (possibly many times). The user can manage this with Sleep mode and/or reading voltage status bits, if such cycling is an issue.

Bit 7: SMP. This bit controls whether or not the SMP will turn on when the supply (Vdd) voltage has dropped below the trip point set by VM[2:0]. The SMP is enabled when the SMP bit is ‘0’. Thus, the SMP is on by default. If this bit is set to ‘1’ the SMP will not turn on regardless of the supply voltage level. Refer to the table titled “[PSoC Devices System Resource Availability](#)” on page 454 to determine if your PSoC device can use this bit.

Bits 5 and 4: PORLEV[1:0]. These bits set the Vdd level at which PPOR switches to one of three valid values. Note that 11b is a reserved value and therefore should not be used. The three valid settings for these bits are:

- 00b (3V or 2.4V operation)
- 01b (4.5V or 3.0V operation)
- 10b (4.75V operation)

See the “DC POR and LVD Specifications” table in the Electrical Specifications section of the PSoC device data sheet for voltage tolerances for each setting.

Bit 3: LVDTBEN. This bit is AND’ed with LVD to produce a throttle-back signal that reduces CPU clock speed, when low voltage conditions are detected. When the Throttle-Back signal is asserted, the CPU speed bits in the OSC_CR0 register are reset, forcing the CPU speed to 3 MHz or EXTCLK / 8.

Bits 2 to 0: VM[2:0]. These bits set the Vdd level at which LVD and the Pump Comparator switches. Refer to the table titled “[PSoC Devices System Resource Availability](#)” on page 454 to determine if your PSoC device has the Switch Mode Pump (SMP).

See the “DC POR and LVD Specifications” table in the Electrical Specifications section of the PSoC device data sheet for voltage tolerances for each setting.

For additional information, refer to the [VLT_CR register](#) on page 294.

32. POR and LVD



This chapter briefly discusses the POR and LVD circuits and their associated registers. For a complete table of the POR and LVD registers, refer to the “[Summary Table of the System Resource Registers](#)” on page 455. For a quick reference of all PSoC registers in address order, refer to the [Register Details](#) chapter on page 147.

32.1 Architectural Description

The Power on Reset (POR) and Low Voltage Detect (LVD) circuits provide protection against low voltage conditions. The POR function senses V_{dd} and holds the system in reset until the magnitude of V_{dd} will support operation to specification. The LVD function senses V_{dd} and provides an interrupt to the system when V_{dd} falls below a selected **threshold**. Other outputs and status bits are provided to indicate important voltage trip levels.

Refer to [Section 30.2 Pin Behavior During Reset](#) for a description of GPIO pin behavior during power up.

32.2 PSoC Device Distinctions

For the CY8C24x23A, CY8C21x34, CY8C21x23, CY7C603xx, and CYWUSB6953 PSoC devices, the lowest POR and LVD trip level is set for 2.4V operation; the next lowest is set for 3.0V operation (instead of 3.0V or 4.5V operation). Refer to the PSoC data sheets for electrical specification information.

32.3 Register Definitions

The following registers are associated with the POR and LVD, and are listed in address order. The register descriptions below have an associated register table showing the bit structure. Depending on how many analog columns your PSoC device has (see the Cols. column in the register tables below), only certain bits are accessible to be read or written (refer to the table titled “[PSoC Device Characteristics](#)” on page 22).

The bits that are grayed out in the register tables are reserved bits and are not detailed in the register descriptions that follow. Reserved bits should always be written with a value of ‘0’. For a complete table of the POR and LVD registers, refer to the “[Summary Table of the System Resource Registers](#)” on page 455.

32.3.1 VLT_CR Register

Addr.	Name	Cols.	Bit 7	Bit 6	Bit 5	Bit 4	Bit 3	Bit 2	Bit 1	Bit 0	Access
1,E3h	VLT_CR	4, 2	SMP		PORLEV[1:0]		LVDTBEN		VM[2:0]		RW : 00
		1			PORLEV[1:0]		LVDTBEN		VM[2:0]		

The Voltage Monitor Control Register (VLT_CR) is used to set the trip points for POR, LVD, and the supply pump.

The VLT_CR register is cleared by all resets, which can cause reset cycling during very slow supply ramps to 5V when the POR range is set for the 5V range. This is because the reset clears the POR range setting back to 3V and a new boot/start-up occurs (possibly many times). The user can manage this with Sleep mode and/or reading voltage status bits, if such cycling is an issue.

Bit 7: SMP.

This bit controls whether or not the SMP will turn on when the supply (Vdd) voltage has dropped below the trip point set by VM[2:0]. The SMP is enabled when the SMP bit is '0'. Thus, the SMP is on by default. If this bit is set to '1' the SMP will not turn on regardless of the supply voltage level. Refer to the table titled “PSoC Devices System Resource Availability” on page 454 to determine if your PSoC device can use this bit. Also refer to the Switch Mode Pump (SMP) chapter on page 509 for additional information.

Bits 5 and 4: PORLEV[1:0].

These bits set the Vdd level at which PPOR switches to one of three valid values. Note that 11b is a reserved value and therefore should not be used.

The three valid settings for these bits are:

- 00b (3V or 2.4V operation)
- 01b (4.5V or 3.0V operation)
- 10b (4.75V operation)

See the “DC POR and LVD Specifications” table in the Electrical Specifications section of the PSoC device data sheet for voltage tolerances for each setting.

Bit 3: LVDTBEN.

This bit is AND’ed with LVD to produce a throttle-back signal that reduces CPU clock speed when low voltage conditions are detected. When the Throttle-Back signal is asserted, the CPU speed bits in the OSC_CR0 register are reset, forcing the CPU speed to 3 MHz or EXTCLK / 8.

Bits 2 to 0: VM[2:0].

These bits set the Vdd level at which LVD and the Pump Comparator switches. Refer to the table titled “PSoC Devices System Resource Availability” on page 454 to determine if your PSoC device has the Switch Mode Pump (SMP).

See the “DC POR and LVD Specifications” table in the Electrical Specifications section of the PSoC device data sheet for voltage tolerances for each setting.

For additional information, refer to the VLT_CR register on page 294.

32.3.2 VLT_CMP Register

Add.	Name	Cols.	Bit 7	Bit 6	Bit 5	Bit 4	Bit 3	Bit 2	Bit 1	Bit 0	Access
1,E4h	VLT_CMP	4, 2						PUMP	LVD	PPOR	R : 00
		2L *					NoWrite	PUMP	LVD	PPOR	
		1							LVD	PPOR	

* The 2L column row is only applicable to the CY8C21x34, CY8C21x23, CY7C603xx, and CYWUSB6953 PSoC devices, which have two column limited functionality.

The Voltage Monitor Comparators Register (VLT_CMP) is used to read the state of internal supply voltage monitors.

Bit 3: NoWrite. This bit is only used in PSoC devices with a 2.4V minimum POR. It reads the state of the Flash write voltage monitor.

Bit 2: PUMP. This bit reads the state of the Switch Mode Pump Vdd comparator. The trip points for both LVD and PUMP are set by VM[2:0] in the VLT_CR register. Refer to the table titled “PSoC Devices System Resource Availability” on page 454 to determine if your PSoC device can use this bit. Also refer to the Switch Mode Pump (SMP) chapter on page 509 for additional information.

Bit 1: LVD. This bit reads the state of the low voltage detect comparator. The trip points for both LVD and PUMP are set by VM[2:0] in the VLT_CR register. Refer to the table titled “PSoC Devices System Resource Availability” on page 454 to determine if your PSoC device can use this bit.

Bit 0: PPOR. This bit reads back the state of the PPOR output. This can only be meaningfully read with POR-LEV[1:0] set to disable PPOR. In that case, the PPOR status bit shows the comparator state directly.

For additional information, refer to the VLT_CMP register on page 295.

33. IO Analog Multiplexer



This chapter explains the chip-wide IO Analog Multiplexer for the CY8C24x94, CY8C21x34, CY7C64215, CY7C603xx, and CYWUSB6953 PSoC devices and its associated registers. For a complete table of the IO Analog Multiplexer registers, refer to the “Summary Table of the System Resource Registers” on page 455. For a quick reference of all PSoC registers in address order, refer to the Register Details chapter on page 147.

33.1 Architectural Description

The CY8C24x94, CY8C21x34, CY7C64215, CY7C603xx, and CYWUSB6953 PSoC devices contains an enhanced analog multiplexer (mux) capability. This function allows many IO pins to connect to a common internal analog bus. In the CY8C21x34, CY7C603xx, and CYWUSB6953 all IO pins connect to this bus. In the CY8C24x94 and CY7C64215, all IO pins except Port 7 pins connect to this bus.

Any number of pins can be connected simultaneously, and dedicated support circuitry allows selected pins to be alternately charged high or connected to the bus. The analog bus can be connected as an input into either the positive or negative inputs of any analog continuous time (CT) block. A block diagram is shown in Figure 33-1.

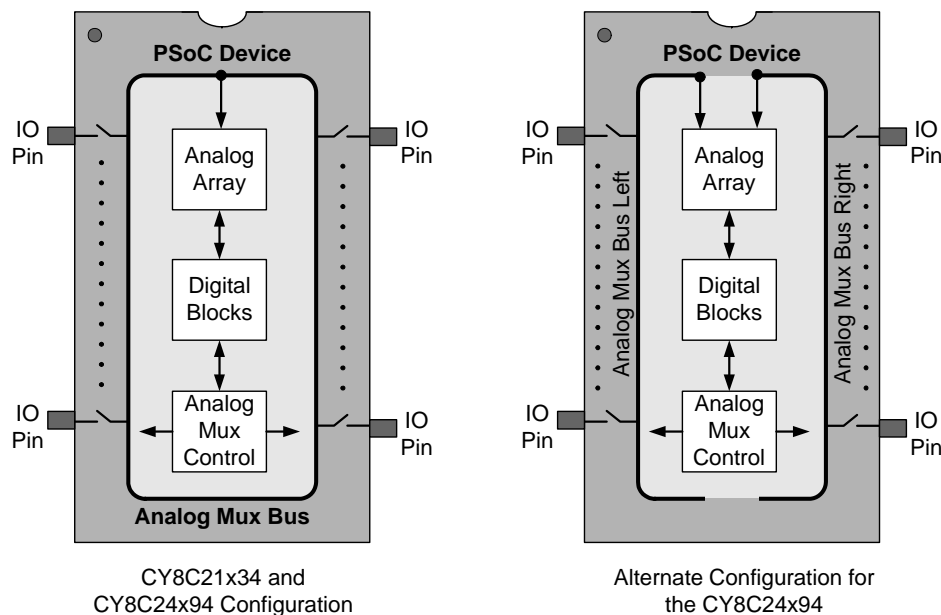

Figure 33-1. Analog Mux System for the CY8C24x94, CY8C21x34, CY7C64215, CY7C603xx, and CYWUSB6953

In the CY8C24x94 and CY7C64215 PSoC devices, the Analog Mux Bus can be split into two separate nets, as shown in Figure 33-1. The two analog mux nets can be connected to different analog columns for simultaneous signal processing.

For each pin, the mux capability exists in parallel with the normal GPIO cell described in the [General Purpose IO \(GPIO\) chapter on page 103](#) and shown in Figure 33-2. Normally, the associated GPIO pin is put into a high-impedance state for these applications, although there are cases where the GPIO cell is configured by the user to briefly drive pin initialization states as described below.

Pins are individually connected to the internal bus by setting the corresponding bits in the MUX_CRx registers. Any number of pins can be enabled at the same time. At reset, all of these mux connections are open (disconnected).

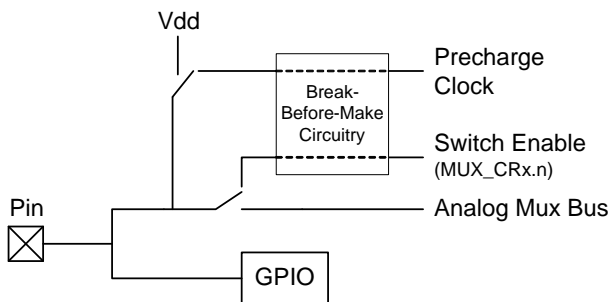

Figure 33-2. IO Pin configuration for the CY8C21x34, CY7C603xx, and CYWUSB6953

33.2 PSoC Device Distinctions

The CY8C24x94, CY8C21x34, CY7C64215, CY7C603xx, and CYWUSB6953 PSoC devices differs from the other PSoC devices in that GPIO pins can connect to the internal analog bus. The CY8C24x94 and CY7C64215 contain the additional capability to optionally split the analog bus into two separate sections. In the CY8C21x34, CY7C603xx, and CYWUSB6953, all GPIO pins are enabled for this connection. In the CY8C24x94 and CY7C64215, all pins in Ports 0 through 5 are enabled for connection to the analog bus.

33.3 Application Description

The analog mux circuitry enables a variety of unique applications such as those explained in the sections below.

33.3.1 Capacitive Sensing

The analog mux supports capacitive sensing applications through the use of the IO analog multiplexer and its control circuitry. Two off-chip capacitors are normally connected to the analog mux bus. One is the sense capacitor being measured and the other is an integration capacitor that accumulates charge from the sense capacitor. The integration capacitor is initialized (low) under firmware control, using its pin's GPIO cell. After that, the capacitor is charged through charge-sharing with the sense capacitor.

The sense capacitor can be automatically initialized and sensed for a number of cycles, in order to build up sufficient charge on the integration capacitor. Several clocking choices are available for selection in the AMUX_CFG register. The **break-before-make** circuitry is contained in each pin's mux so that each cycle's initialization of the sense capacitor does not disturb the internal bus. The sense capacitor is charged to Vdd and then released and re-connected to the analog mux for charge transfer to the integration capacitor.

Charge accumulation on the integration capacitor continues for a time set by the user. The integration capacitor voltage, seen on the analog mux bus, is typically compared against a reference such as the bandgap. Detecting a capacitance change is often more important than an absolute measurement, and a change in the charging time can indicate such a difference. A system with several sense capacitors can be measured in sequence, using the same integration capacitor.

A pin used as the integration capacitor is not switched during this process, so it remains connected to the analog mux. Two Port 0 pins are available for this function, as shown in Figure 33-3.

In order to activate the charge transfer mode, the precharge clock must be set to any state except the reset state. In the reset state, the mux connections are static, controlled only by the MUX_CRx register settings. The CY8C24x94 and CY7C64215 PSoC devices can be configured to have two Analog Mux Bus nets because it supports two simultaneous capacitive sensing operations.

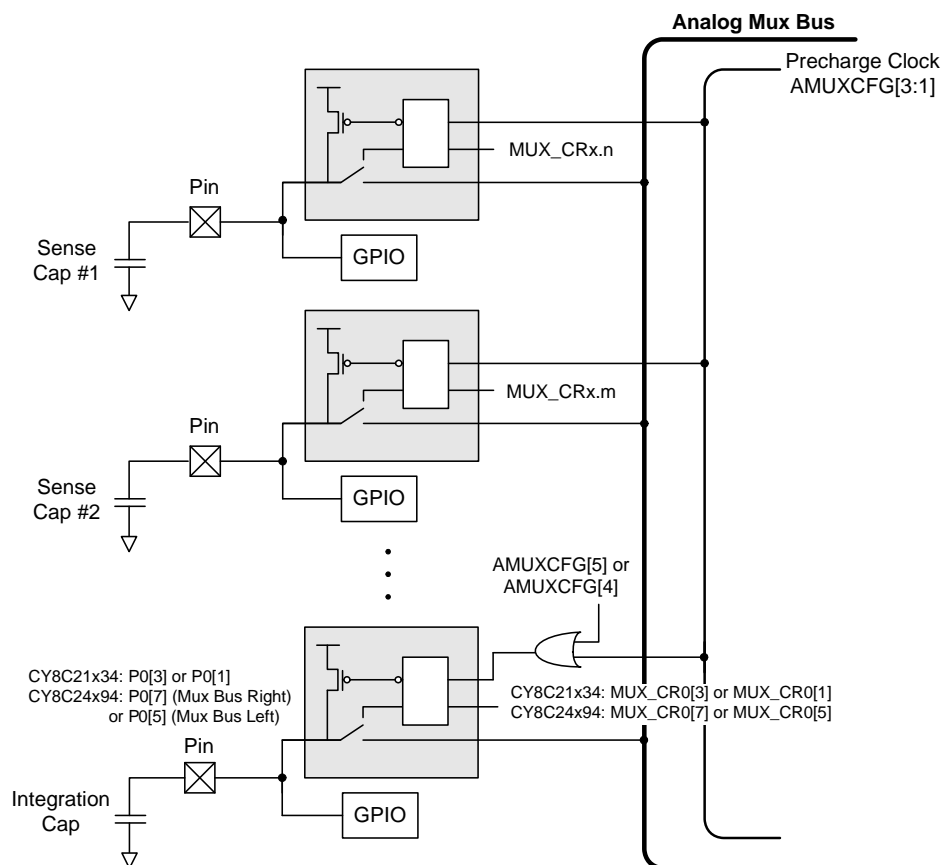

Figure 33-3. CY8C24x94, CY8C21x34, CY7C64215, CY7C603xx, CYWUSB6953 Capacitance Sense Example Diagram

33.3.2 Chip-Wide Analog Input

The analog bus forms a multiplexer across many IO pins. This allows any of these pins to be brought into the analog system for processing, as shown in Figure 33-1. The Port 0 pins are also brought through separate mux paths to the continuous time block, so Port 0 inputs can be routed to the analog system by either path. In the CY8C24x94 and CY7C64215, some Port 2 inputs have a dedicated path to switched capacitor blocks.

In the CY8C21x34, CY7C603xx, and CYWUSB6953 PSoC devices, the pins can be connected to a single bus. In the CY8C24x94 and CY7C64215 PSoC devices, odd pins are connected to one bus, even pins to the other bus. The two mux buses can be shorted together using the switch controlled by the SplitMux bit.

33.3.3 Crosspoint Switch

The bidirectional nature of the analog mux switches allows a direct connection between any of the IO pins, as shown in Figure 33-1. Enabling two (or more) pins at the same time connects these pins together, with approximately 400 ohms of resistance between each pin and the analog mux bus. As long as the clock choice in the AMUX_CFG register is set to the fixed '0' case, the switches will be static, controlled only by the state of the individual switch enable bits in the MUX_CRx registers. The crosspoint can be reconfigured at any time and the user can provide a break-before-make function with firmware if needed.

33.3.4 Charging Current

The analog mux bus can be connected to the dedicated charging current. This enables applications such as capacitor measurement with this current instead of charge sharing. The DAC_D and DAC_CR registers control this configurable current. If the CY8C24x94 and CY7C64215 PSoC devices are configured with a split analog mux bus, this current connects only to the right-side bus (even pin numbers).

33.4 Register Definitions

The following registers are only associated with the Analog Bus Mux in the CY8C24x94, CY8C21x34, CY7C64215, CY7C603xx, and CYWUSB6953 PSoC devices and are listed in address order within their system resource configuration. For a complete table of the IO Analog Multiplexer registers, refer to the “[Summary Table of the System Resource Registers](#)” on [page 455](#). Each register description has an associated register table showing the bit structure for that register. Register bits that are grayed out throughout this document are reserved bits and are not detailed in the register descriptions that follow. Reserved bits should always be written with a value of ‘0’.

33.4.1 AMUX_CFG Register

Address	Name	Bit 7	Bit 6	Bit 5	Bit 4	Bit 3	Bit 2	Bit 1	Bit 0	Access
0,61h	AMUX_CFG	BCol1Mux	ACol0Mux	INTCAP[1:0]		MUXCLK[2:0]			EN	RW : 00

The Analog Mux Configuration Register (AMUX_CFG) is used to configure the clocked pre-charge mode of the analog multiplexer system. This register is only used by the CY8C24x94, CY8C21x34, CY7C64215, CY7C603xx, and CYWUSB6953 PSoC devices.

Bit 7: BCol1Mux. This bit selects the column 1 port input. It picks between port 0 inputs or the analog mux bus. This bit is only available in the CY8C24x94 and CY7C64215 PSoC devices. See the figure titled “[Two Column PSoC Analog Pin Block Diagram for USB](#)” on [page 406](#).

Bit 6: ACol0Mux. This bit selects the column 0 port input. It picks between port 0 inputs or the analog mux bus. This bit is only available in the CY8C24x94 and CY7C64215 PSoC devices. See the figure titled “[Two Column PSoC Analog Pin Block Diagram for USB](#)” on [page 406](#).

Bits 5 and 4: INTCAP[1:0]. These bits are used to choose static connections to the analog mux bus even if the mux clocking is enabled in the MUXCLK[2:0] setting.

Bits 3 to 1: MUXCLK[2:0]. These bits select the precharge clock that drives the switching on the analog mux. The default choice is to have no clocking and no precharge.

Bit 0: EN. This bit enables the clock output. When the block is disabled, the output is ‘0’.

For additional information, refer to the [AMUX_CFG register on page 177](#).

33.4.2 DAC_D Register

Address	Name	Bit 7	Bit 6	Bit 5	Bit 4	Bit 3	Bit 2	Bit 1	Bit 0	Access
0,FDh	DAC_D	DACDATA[7:0]								RW : 00

The Analog Mux DAC Data Register (DAC_D) specifies the 8-bit multiplying factor that determines the output DAC current. This register is only used by the CY8C24x94, CY8C21x34, CY7C64215, CY7C603xx, and CYWUSB6953 PSoC devices.

Bits 7 to 0: DACDATA[7:0]. The 8-bit value in this register sets the current driven onto the analog mux bus when the current DAC mode is enabled.

For additional information, refer to the [DAC_D register on page 250](#).

33.4.3 AMUX_CLK Register

Address	Name	Bit 7	Bit 6	Bit 5	Bit 4	Bit 3	Bit 2	Bit 1	Bit 0	Access
1,AFh	AMUX_CLK							CLKSYNC[1:0]		RW : 00

The Analog Mux Clock Register (AMUX_CLK) is used to adjust the phase of the clock to the analog mux bus. This register is only used by the CY8C24x94 and CY7C64215 PSoC devices.

Bits 1 and 0: CLKSYNC[1:0]. These bits select the synchronization clock for the analog mux precharge clock.

For additional information, refer to the [AMUX_CLK register](#) on page 280.

33.4.4 MUX_CRx Registers

Address	Name	Bit 7	Bit 6	Bit 5	Bit 4	Bit 3	Bit 2	Bit 1	Bit 0	Access
1,D8h	MUX_CR0					ENABLE[7:0]				RW : 00
1,D9h	MUX_CR1					ENABLE[7:0]				RW : 00
1,DAh	MUX_CR2					ENABLE[7:0]				RW : 00
1,DBh	MUX_CR3					ENABLE[7:0]				RW : 00
1,ECh	MUX_CR4					ENABLE[7:0]				RW : 00
1,EDh	MUX_CR5					ENABLE[7:0]				RW : 00

The Analog Mux Port Bit Enables Registers (MUX_CRx) are used to control the connection between the analog mux bus and the corresponding pin.

are only used by the CY8C24x94 and CY7C64215 PSoC devices.

The CY8C21x34, CY7C603xx, and CYWUSB6953 have a 4-bit wide Port 3. The upper 4 bits of the MUX_CR3 register are reserved in that device and will return zeros when read. The MUX_CRx registers with addresses 1,ECh and 1,EDh

Bits 7 to 0: ENABLE[7:0]. The bits in these registers enable connection of individual pins to the analog mux bus. Each IO port has a corresponding MUX_CRx register.

For additional information, refer to the [MUX_CRx register](#) on page 287.

33.4.5 DAC_CR Register

Address	Name	Bit 7	Bit 6	Bit 5	Bit 4	Bit 3	Bit 2	Bit 1	Bit 0	Access
1,FDh	DAC_CR	SplitMux	MuxClkGE			IRANGE	OSCMODE[1:0]		ENABLE	RW : 00

The Analog Mux DAC Control Register (DAC_CR) contains the control bits for the DAC current that drives the analog mux bus and for selecting the split configuration for the CY8C24x94 and CY7C64215 PSoC devices. This register is only used by the CY8C24x94, CY8C21x34, CY7C64215, CY7C603xx, and CYWUSB6953 PSoC devices.

Bit 3: IRANGE. This bit selects the two current ranges that are available for the DAC.

Bit 7: SplitMux. This bit allows the analog mux bus to be configured as two separate nets. This bit is only used in the CY8C24x94 and CY7C64215 PSoC devices.

Bits 2 and 1: OSCMODE[1:0]. These bits, when set, enable the analog mux bus to reset to Vss whenever the comparator trip point is reached.

Bit 6: MuxClkGE. This bit controls connection of the analog mux bus clock signal to a global in the CY8C24x94 and CY7C64215 PSoC devices.

Bit 0: ENABLE. This bit controls whether or not the DAC mode is enabled.

For additional information, refer to the [DAC_CR register](#) on page 305.

34. Full-Speed USB



This chapter explains the Full-Speed USB (Universal Serial Bus) resource and its associated registers. For a complete table of the registers associated with the full-speed USB, refer to the “[Summary Table of the System Resource Registers](#)” on [page 455](#). For a quick reference of all PSoC registers in address order, refer to the [Register Details](#) chapter on [page 147](#).

34.1 Architectural Description

The PSoC USB system resource adheres to the USB 2.0 specifications for full-speed devices operating at 12 Mb/sec-ond with one upstream port and one USB address. PSoC USB consists of the following components:

- Serial Interface Engine (SIE) block
- PSoC Memory Arbiter (PMA) block
- 256 bytes of dedicated SRAM
- A Full-Speed USB Transceiver with internal regulator and two dedicated USB pins

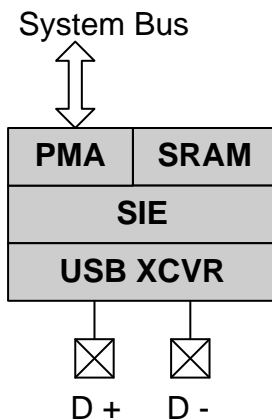

Figure 34-1. USB Block Diagram

At the PSoC system level, the full-speed USB system resource interfaces to the rest of the PSoC by way of the M8C's register access instructions and to the outside world by way of the two USB pins.

The SIE supports five endpoints including a control endpoint (endpoint 0) and four data endpoints (endpoint 1, 2, 3, and 4). The control endpoint can be configured to support SETUP, IN, and OUT requests. The data endpoints can be individually configured to respond to Interrupt, Bulk, or Isochronous IN or OUT requests.

34.2 Application Description

The individual components and issues of the USB system are described in detail in the following sections.

34.2.1 USB SIE

The USB Serial Interface Engine (SIE) allows the PSoC device to communicate with the USB host at full-speed data rates (12 Mb/s). The SIE simplifies the interface to USB traffic by automatically handling the following USB processing tasks without firmware intervention:

- Translate the encoded received data and format the data to be transmitted on the bus.
- CRC Checking and Generation. Incoming packets failing checksum verification are ignored.
- Address Checking. Ignores all transactions not addressed to the device.
- Sends appropriate ACK/NAK/Stall handshakes.
- Identifies token type (SETUP, IN, OUT) and sets the appropriate token bit once a valid token is received.
- Identifies Start-of-Frame (SOF) and saves the frame count.
- Sends data to or retrieves data from the USB SRAM, by way of the PSoC Memory Arbiter.

Firmware is required to handle various parts of the USB interface. The SIE issues interrupts after key USB events to direct firmware to appropriate tasks:

- Fill and empty the USB data buffers in USB SRAM.
- Enable PMA channels appropriately.
- Coordinate enumeration by decoding USB device requests.
- Suspend and resume coordination.
- Verify and select data toggle values.

Table 34-1. Mode Encoding for Control and Non-Control Endpoints

Encoding	Mode	SETUP	IN	OUT	Comments
0h	Disable	Ignore	Ignore	Ignore	Ignore all USB traffic to this endpoint.
1h	NAK IN/OUT	Accept	NAK	NAK	NAK IN and OUT token.
2h	Status OUT Only	Accept	STALL	Check	For control endpoint, STALL IN and ACK zero byte OUT.
3h	Status IN/ OUT	Accept	STALL	STALL	For control endpoint, STALL IN and OUT token.
4h	Reserved	Ignore	Ignore	Ignore	
5h	ISO OUT	Ignore	Ignore	Always	Isochronous OUT.
6h	Status IN Only	Accept	TX 0 Byte	STALL	For control endpoint, STALL OUT and send zero byte data for IN token.
7h	ISO IN	Ignore	TX Count	Ignore	Isochronous IN.
8h	NAK OUT	Ignore	Ignore	NAK	Send NAK handshake to OUT token.
9h	ACK OUT (Stall = 0)	Ignore	Ignore	ACK	This mode is changed by the SIE to mode 8h on issuance of ACK handshake to an OUT.
9h	ACK OUT (Stall = 1)	Ignore	Ignore	STALL	STALL the OUT transfer.
Ah	Reserved	Ignore	Ignore	Ignore	
Bh	ACK OUT – Status IN	Accept	TX 0 Byte	ACK	ACK the OUT token or send zero byte data for IN token.
Ch	NAK IN	Ignore	NAK	Ignore	Send NAK handshake for IN token.
Dh	ACK IN (Stall = 0)	Ignore	TX Count	Ignore	The mode is changed by the SIE to mode Ch after receiving ACK handshake to an IN data.
Dh	ACK IN (Stall = 1)	Ignore	STALL	Ignore	STALL the IN transfer.
Eh	Reserved	Ignore	Ignore	Ignore	
Fh	ACK IN – Status OUT	Accept	TX Count	Check	Respond to IN data or Status OUT.

34.2.2 USB SRAM

The PSoC USB System Resource contains a dedicated 256 byte SRAM. This SRAM is identical to an SRAM page used in the PSoC Core; however, it is not accessible by way of the M8C memory access instructions. The PSoC USB's dedicated SRAM may only be accessed by way of the PMA registers. For more information on how to use the PSoC USB's dedicated SRAM see the next section, PSoC Memory Arbiter (PMA).

The USB SRAM contents are not directly affected by any reset, but should be treated as unknown after any POR, WDR, and XRES.

34.2.2.1 PSoC Memory Arbiter

The PSoC Memory Arbiter (PMA) is the interface between the PSoC USB's dedicated SRAM and the two blocks that access the SRAM: the M8C and the USB SIE. The PMA provides eight channels to manage data. All of the channel registers may be used by the M8C, but the four non-control USB endpoints are each allocated to a specific set of PMA channel registers. It is the responsibility of the firmware to insure that the M8C is not accessing a set of channel registers that are in use by the USB SIE. If the M8C wants to access the same data that an SIE channel is using, two channels should be configured to access the same SRAM address ranges. Table 34-2 shows the mapping between PMA channels and which blocks can use them.

Table 34-2. PMA Channel Assignments

PMA Channel	USB SIE	M8C	Channel Registers (PMAx_xx)
0		✓	PMA0_DR, PMA0_RA, PMA0_WA
1	EP1	✓	PMA1_DR, PMA1_RA, PMA1_WA
2	EP2	✓	PMA2_DR, PMA2_RA, PMA2_WA
3	EP3	✓	PMA3_DR, PMA3_RA, PMA3_WA
4	EP4	✓	PMA4_DR, PMA4_RA, PMA4_WA
5		✓	PMA5_DR, PMA5_RA, PMA5_WA
6		✓	PMA6_DR, PMA6_RA, PMA6_WA
7		✓	PMA7_DR, PMA7_RA, PMA7_WA

The PMA's purpose is to manage the potentially conflicting SRAM access requests from the M8C and the USB SIE. From a performance standpoint, the PMA guarantees that a continuous stream of move instructions (see below), will be serviced by the PMA without delay even while the USB SIE is transferring data at its maximum rate into or out of the dedicated PSoC USB SRAM.

When servicing a request, the PMA will be in one of two addressing modes. For M8C access the PMA always uses Post-Increment Addressing. After a read or write request is made to the channel's PMAx_DR register, the PMA automatically increments the pointer into SRAM. For a read access the next value is also automatically pre-fetched. For USB SIE accesses, the PMA will use an offset addressing mode. In this mode the channel's base address, as stored in the PMAx_WA and PMAx_RA registers, is added to the byte count offset provided by the USB SIE.

A PMA channel does not have a defined upper limit. It is the responsibility of the firmware to ensure that channels do not access memory outside of the range defined by the application.

During SIE writes to the USB SRAM, the maximum number of bytes written is limited to the count value in the respective endpoint's count registers. This value must be loaded by firmware before data is received. See the [EPx_CNT Register register on page 532](#) for more information.

The rest of the description of the PMA is broken into two parts: the M8C interface and the USB SIE interface.

PMA to M8C Interface

The M8C accesses the PMA, and thus the PSoC USB's dedicated SRAM by way of a register interface. Each PMA channel has three registers associated with it as shown in [Table 34-2](#). Only the following basic M8C register access instructions may be used with these registers.

- `MOV A, reg[expr]`
- `MOV A, reg[X+expr]`
- `MOV [expr], [expr]`
- `MOV reg[expr], A`
- `MOV reg[X+expr], A`
- `MOV reg[expr], expr`
- `MOV reg[X+expr], expr`

When the M8C uses a PMA channel to write data into SRAM, the following steps should be followed.

1. Choose a PMA channel that is not allocated to a USB endpoint, or choose a channel where the endpoint is inactive.
2. Write the channel's PMAx_WA register with the first address in SRAM that should be used by this channel.
3. Write data to the channel's PMAx_DR register. The PMA logic automatically increments the PMAx_WA address after each write.

While the steps above are being executed by the M8C, the USB SIE may be fully active on any other PMA channel. The M8C may also service another channel and come back to the channel being serviced by the steps above. To determine the next address that will be used when data is written to the channel's PMAx_DR register, the PMAx_WA register may be read.

When the M8C uses a PMA channel to read data from SRAM, the following steps should be followed.

1. Choose a PMA channel that is not allocated to a USB endpoint, or choose a channel where the endpoint is inactive.
2. Write the channel's PMAx_RA register with the first address in SRAM that should be read by this channel.
3. Read data from the channel's PMAx_DR register. The PMA logic automatically increments the PMAx_RA address after each read.

When data is read from a PMA channel the data is pre-fetched; therefore, the channel must be pre-loaded prior to the first M8C read that expects to get actual data. This pre-loading is taken care of automatically when the PMAx_RA register is written. This pre-loading mechanism is actually the only difference between the PMAx_RA and PMAx_WA registers.

PMA to USB SIE Interface

The USB SIE accesses the PMA and thus the dedicated 256 byte SRAM by way of a private interface and does not affect the PSoC Core address or data bus. The only area of contention that is not automatically arbitrated between the M8C, PMA, and USB SIE are the PMAx_xx registers. When the USB SIE is actively using a PMA channel, the M8C should not attempt to access that channel's PMA registers. If the M8C wants to access the same data as an active USB endpoint, the M8C should use a PMA channel separate from the PMA channel that is permanently allocated to that endpoint.

Just as the M8C has two uses for PMA channels, read or write, the USB SIE has two uses for a PMA channel. The USB SIE's use of a channel may be thought of as read or write; but, in USB terms the USB SIE's need to read data would be associated with an IN transaction and the need to write data with a OUT transaction.

For a USB IN transaction, the PSoC USB SIE will be reading data from the PMA and sending the data to the USB host. The following steps should be used to set up a PMA channel for a USB IN transaction. These steps assume that the data has already been written by the M8C into the dedicated 256 byte SRAM.

1. Select the PMA channel whose number matches the endpoint number that will be handling the IN transaction.
2. Write the PMA channel's PMAx_RA register with the address of the first byte in SRAM that will be used for the IN transaction.
3. Configure the USB endpoint registers with the proper byte count and enable the endpoint to send data when the IN transaction occurs.

Because the PMA pre-fetches data for M8C and USB SIE reads, step two above is very important. This step not only sets the first address from which data is read by the USB SIE; but, it also triggers a read operation on the dedicated 256 byte SRAM and stores the result of that read in the PMAx_DR ready for the USB SIE to read. When the USB SIE begins the IN transaction for the endpoint, it will use its byte counter to tell the PMA which byte is needed next. Therefore, when the first byte of the transaction is read by the SIE, the PMA will automatically fetch the next byte in preparation for the USB SIE's next byte request.

For a USB OUT transaction, the PSoC USB SIE will be writing data to the PMA that was received from the USB host. The following steps should be used to set up a PMA channel for a USB OUT transaction.

1. Select the PMA channel whose number matches the endpoint number that will be handling the OUT transaction.
2. Write the PMA channel's PMAx_WA register with the address of the first byte in SRAM that will be used for the OUT transaction.
3. Configure the USB endpoint with the proper maximum receive byte count and enable the endpoint to receive the OUT transaction.

As with the IN transaction, the PMA will use the byte counter from the SIE as an offset to the value of the PMAx_WA register. As the USB SIE sends bytes to the PMA, the counter will be added to the base address and the data byte will be written into the dedicated 256 byte SRAM. Should an error occur in the OUT transaction and the packet be resent by the USB host, the byte count will be reset to zero and the PMA will write the new data over top of the potentially corrupt data from the previous failed transaction.

If the number of bytes received exceeds the count in the endpoint's count register, the extra bytes will not be written into the USB SRAM, but the received byte count reported in the endpoint count registers will include the ignored bytes.

Ping Ponging Endpoint Buffers

It is possible to setup the USB PMA so that endpoint data does not need to be processed before the next USB packet is received. This is done by simply changing the channels WA or RA register value. For example, when an interrupt is received indicating that a packet has been received, rather than processing the data and then enabling the endpoint to receive more data, simply change the write address (WA) for the PMA channel used by the endpoint to a free area of the USB RAM. By doing this, you allow the USB SIE to receive more data while the M8C is processing the previously received data. A similar method may be used to prepare data to be sent by way of an IN transaction.

34.2.3 Oscillator Lock

The CY8C24x94 and CY7C64215 PSoC devices can operate without using any external components, such as a crystal, and still achieve the clock accuracy required for full-speed USB. It does this by locking its internal oscillator to the incoming USB traffic. Therefore, the initial accuracy of the oscillator may not meet the required accuracy (+/- 0.25%), but it will self-tune to this precision before the device needs to transmit USB data.

This oscillator locking feature is disabled by default and must be enabled by firmware. In USB systems, this feature should always be enabled unless the device is being used with an accurate external clock. The EnableLock bit, in the USB_CR1 register, is used to turn on the locking feature.

34.2.4 Transceiver

The internal USB transceiver interfaces to the external USB bus to transmit and receive signals according to the USB 2.0

Specification. In normal USB operation, the transceiver interfaces directly to the SIE and no user interaction is needed after initialization. The USB Enable bit should not be set for this mode of operation. The transceiver can also be used in non-USB modes, since the D+ and D- pins can be read and written through register control bits. The USB Enable bit in the USB_CR0 register must be set to enable the transceiver for USB operation. This enables multi-purpose use of these pins (for example, in a system that supports both USB and PS/2 signaling).

For USB operation, the transceiver contains an internal 1.5 k Ω pull-up resistor on the D+ line. This resistor is isolated from the D+ pin at reset and is attached under firmware control through the USBPUEN bit in the USBIO_CR1 register. Once the D+ pull-up resistor is connected to the D+ line, the system will normally detect that as an attach and begin the USB enumeration process.

No additional external pull-up resistor should be added to the D+ line, since the transceiver signaling is optimized for use with the internal D+ pull-up resistor. However, low value series resistors (24 Ω) must be added externally to meet the driving impedance requirement for full-speed USB, as shown in [Figure 34-2](#).

The transceiver also includes 5 k Ω pull-up resistors on both the D+ and D- pins for communication at PS/2 or similar signaling levels. These resistors are disconnected at reset and can be connected with the PS2PUEN bit in the USBIO_CR1 register.

The D+ and D- pins can also be driven individually high and low in both USB and non-USB modes. The state of those pins can be read in any mode. Refer to the description of the USBIO_CR0 and USBIO_CR1 register on page [530](#) and page [531](#) for more detail.

34.2.5 Regulator

The PSoC device contains a regulator that can be used to power the transceiver from the USB bus voltage or other supply around 5V. The regulator supplies the proper levels for USB signals, which switch between 0V and 3.3V nominally.

If the PSoC device is operating with a Vdd supply near 3.3V, then the regulator must be placed into a pass-through mode so that the Vdd voltage is directly supplied to the transceiver, without regulation.

The RegEnable bit in the USBIO_CR1 register is used to pick between the regulating mode (5V or USB bus-powered supply) or the pass-through mode (3.3V supply). At power up, the regulator is automatically held in pass-through mode, but the USB transceiver pins are tri-stated. See “USB Suspend Mode” on page 527 regarding regulator operation in USB Suspend mode.

34.2.6 Interrupts

The USB interrupts use interrupt addresses 0040h through 005Ch (see Table 5-1). In other PSoC devices, these interrupts are used for the digital PSoC block interrupts for blocks 20, 21, 22, 23, 30, 31, and 32. These blocks are not implemented in the PSoC devices that support USB. They are the same blocks whose register space is being reused for the USB registers. The USB interrupts are as follows.

Bus Reset. This interrupt occurs, regardless of the state of the USB Enable bit in the USB_CR0 register, whenever a bus reset ends. A USB bus reset is defined as the D+ and D- USB pins being low at the same time for more one to three periods of the PSoC's internal 32 kHz timer. The interrupt asserts once the bus reset condition ends.

Endpoint 0. This interrupt is for control endpoint 0 in the PSoC device. The interrupt occurs after successful transactions with endpoint 0. No interrupts are generated on endpoint 0 transactions that end with a NAK.

Data Endpoints. These interrupts are for data endpoints 1, 2, 3, and 4 in the PSoC device. The individual interrupts occur after successful transactions to their respective endpoints. The interrupts may be optionally disabled for transactions ending with a NAK.

Start of Frame. The Start of Frame (SOF) interrupt, when enabled, occurs on each valid SOF packet received. The frame count from the SOF packet is stored in the USB_SOF0 and USB_SOF1 registers.

USB Wake Interrupt. This interrupt is designed to wake the device from sleep (suspend) state. It asserts on any non-idle USB state (such as D+ low) when the PSoC device is in the sleep state (Sleep bit set in the CPU_SCR0 register).

34.2.7 Reset

At a power-on-reset, watchdog reset, or low-voltage reset, the following conditions apply to the USB system.

- The regulator is in pass-through mode.
- The D+ and D- pins are in a high impedance state.
- The USB (or PS2) pull-up internal resistors are disabled (disconnected from the D+ and/or D- pins).
- The USB device address in the USB_CR0 register is cleared to zero.
- The contents of the USB SRAM are undefined.

If the device was previously attached and USB was activated before the reset, the automatic disconnection of the pull-up resistor will appear as a detach event to the system. When firmware re-enables the pull-up, the system will see the new attach event and a new USB address will be assigned to the device during enumeration.

A USB bus reset event clears the USB_CR0 register, but does not affect any other register in the device. At the end of the bus reset condition, the USB Bus Reset interrupt is asserted.

34.2.8 USB Suspend Mode

Loss of USB activity, while the USB VBus is still asserted, indicates that the PSoC device should enter USB Suspend mode. (Self-powered devices do not need to go into Suspend mode.) This condition is detected by monitoring the BusActivity bit in the USB_CR1 register. This bit should be polled periodically. If it reads high (bus activity present), it should be cleared by firmware. If no activity is detected for the desired time (for example, 3 ms), the device should enter Suspend mode.

To enter Suspend mode, firmware powers down the desired functions, as it would to enter a low-power sleep state, including writing the Sleep bit of the CPU_SCR0 register. The USB regulator settings should not be changed when entering sleep state, since the regulator automatically enters a low power state for the given mode (pass-through or regulating).

The special USB wake interrupt must be enabled to allow the device to exit the sleep state when there is activity on the USB bus. This interrupt can be enabled at any time since it will only assert when the device is in the sleep state. Other interrupts may be optionally enabled, such as the sleep interrupt, to periodically wake the device while in USB suspend state. If D+ is low when the Sleep bit is being set, the device will briefly enter sleep state, and then exit sleep due to the USB wake interrupt.

By carefully using a sleep timer interrupt, the device can wake periodically, monitor the environment, and return to sleep while maintaining a low average current that meets the USB suspend current specification.

If the device needs to issue a Resume signal to the USB system, firmware can write to the TEN and TD bits in the USBIO_CR0 register to manually force a K state on the bus. Using these bits produces signaling that meets the USB timing specifications.

1. Drive the J state (TEN=1, TD=1) for one instruction.
2. Drive the resume, or K state, (TEN=1, TD=0) for the proper time (1 ms to 15 ms).
3. Stop driving the USB bus manually (TEN=0).

When driving a resume, the J state (TD=1) must be driven briefly before driving the K state (TD=0). The steps are summarized as follows:

34.2.9 Sample Schematic for USB

Figure 34-2 shows a sample schematic for USB with the 56-pin MLF PSoC device (CY8C24794).

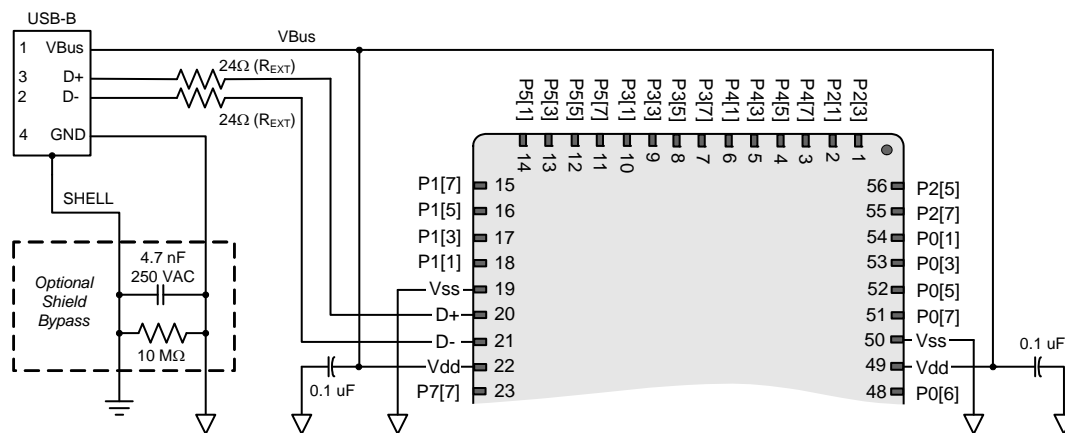

USB Connector Termination Assignment

Contact Number	Signal Name	Typical Wiring Assignment
1	VBUS	Red
2	D-	White
3	D+	Green
4	GND	Black
Shell	Shield	Drain Wire

Figure 34-2. Sample Schematic for USB

34.3 Register Definitions

The following registers are only associated with the Full-Speed USB in the CY8C24x94 and CY7C64215 PSoC devices and are listed in address order within their system resource configuration. For a complete table of the Full-Speed USB registers, refer to the “[Summary Table of the System Resource Registers](#)” on page 455. Each register description has an associated register table showing the bit structure for that register. Register bits that are grayed out throughout this document are reserved bits and are not detailed in the register descriptions that follow. Reserved bits should always be written with a value of ‘0’.

34.3.1 PMAx_DR Register

Address	Name	Bit 7	Bit 6	Bit 5	Bit 4	Bit 3	Bit 2	Bit 1	Bit 0	Access	
0,40h	PMA0_DR									Data[7:0]	RW : 00
0,41h	PMA1_DR									Data[7:0]	RW : 00
0,42h	PMA2_DR									Data[7:0]	RW : 00
0,43h	PMA3_DR									Data[7:0]	RW : 00
0,44h	PMA4_DR									Data[7:0]	RW : 00
0,45h	PMA5_DR									Data[7:0]	RW : 00
0,46h	PMA6_DR									Data[7:0]	RW : 00
0,47h	PMA7_DR									Data[7:0]	RW : 00

The PSoC Memory Arbiter Data Register (PMAx_DR) is used to read and write to a particular PMA channel by either the USB SIE or the M8C. Note that a PMA channel may not be used simultaneously by both the USB SIE and the M8C.

Bits 7 to 0: Data[7:0]. When the M8C writes to this register, the PMA registers the byte and then stores the value at the address in SRAM indicated by the PMAx_WA register. After the value has been written to SRAM, the PMAx_WA register is automatically incremented. When the USB SIE writes to this register, the PMA registers the byte and then stores the value in SRAM using the sum of the value of the PMAx_WA register and the USB SIE's received byte count.

When the M8C reads this register, a pre-loaded value is returned and the PMAx_RA value is automatically incre-

mented. The new PMAx_RA value is used to fetch the next value from the SRAM, to be ready for the next read from the channel's PMAx_DR register. When the USB SIE reads the PMAx_DR register, it also receives a pre-loaded value and this triggers the PMA logic to fetch the next value in SRAM, to be ready for the USB SIE's next read request. In all read cases, the initial pre-load of the first address of the channel was triggered by writing the first address of the channel to the channel's PMAx_RA register. Therefore, the PMAx_RA register must be written after data has been stored for the channel.

For additional information, refer to the [PMAx_DR register on page 164](#).

34.3.2 USB_SOFx Register

Address	Name	Bit 7	Bit 6	Bit 5	Bit 4	Bit 3	Bit 2	Bit 1	Bit 0	Access	
0,48h	USB_SOF0									Frame Number[7:0]	R : 00
0,49h	USB_SOF1									Frame Number[10:8]	R : 00

The USB Start of Frame Registers (USB_SOF0 and USB_SOF1) provide access to the 11-bit SOF frame number. Start of frame packets are sent from the host (for example, the PC) every one ms. For more information, see the *Universal Serial Bus Specification*, revision 2.0.

Bits 10 to 0: Frame Number. The USB_SOF0 register has the lower 8 bits [7:0] and the USB_SOF1 register has the upper 3 bits [10:8] of the SOF frame number.

For additional information, refer to the [USB_SOF0 register on page 165](#) and the [USB_SOF1 register on page 166](#).

34.3.3 USB_CR0 Register

Address	Name	Bit 7	Bit 6	Bit 5	Bit 4	Bit 3	Bit 2	Bit 1	Bit 0	Access	
0,4Ah	USB_CR0	USB Enable	Device Address[6:0]								RW : 00

The USB Control Register 0 (USB_CR0) is used to set the PSoC's USB address and enable the USB system resource.

All bits in this register are reset to zero when a USB bus reset interrupt occurs.

Bit 7: USB Enable. When set, this bit enables the SIE for USB traffic. The device will not respond to USB traffic if this bit is cleared. This bit also enables the USB transceiver when set.

Bits 6 to 0: Device Address[6:0]. These bits specify the USB device address to which the SIE will respond. This address must be set by firmware and is specified by the system with a SETUP command during USB enumeration.

For additional information, refer to the [USB_CR0 register on page 167](#).

34.3.4 USBIO_CR0 Register

Address	Name	Bit 7	Bit 6	Bit 5	Bit 4	Bit 3	Bit 2	Bit 1	Bit 0	Access
0,4Bh	USBIO_CR0	TEN	TSE0	TD					RD	# : 00

LEGEND

#: Access is bit specific. Refer to the [Register Details chapter on page 147](#) for additional information.

The USB IO Control Register 0 (USBIO_CR0) is used for manually transmitting on the USB D+ and D- pins, or reading the differential receiver.

Bit 7:TEN. Setting this bit allows the USB outputs to be driven manually. Normally, TEN is kept low so that the internal hardware can control traffic flow automatically. One application for manual USB mode is driving a resume signal (USB "K") to wake the system from USB suspend.

Bit 6: TSE0. This bit is used to manually transmit a single-ended zero (both D+ and D- low) on the USB pins. This bit has no effect if TEN=0.

Bit 5: TD. This bit is used to manually drive a USB J or K state onto the USB pins. There is no effect if TEN=0, and TSE0 overrides this bit.

Bit 0: RD. This read only bit gives the state of USB Received Data from the differential receiver. The USB Enable bit in the USB_CR0 register must be set to receive data. If the USB Enable bit is not set, this bit will read '0'.

For additional information, refer to the [USBIO_CR0 register on page 168](#).

34.3.5 USBIO_CR1 Register

Address	Name	Bit 7	Bit 6	Bit 5	Bit 4	Bit 3	Bit 2	Bit 1	Bit 0	Access
0,4Ch	USBIO_CR1	IOMode	Drive Mode	DPI	DMI	PS2PUEN	USBPUEN	DPO	DMO	RW : 00

The USB IO Control Register 1 (USBIO_CR1) is used to manually read or write the D+ and D- pins, and to configure internal pull-up resistors on those pins.

Bit 7: IOMode. This bit allows the D+ and D- pins to be configured for either USB mode or bit banded modes. If this bit is set, the DMI and DPI bits are used to drive the D- and D+ pins.

Bit 6: Drive Mode. If the IOMode bit is set, this bit configures the D- and D+ pins for either CMOS drive or open-drain drive. If IOMode is cleared, this bit has no effect. Note that in open drain mode 5 kΩ pull-up resistors can be connected internally with the PS2PUEN bit.

Bit 5: DPI. This bit is used to drive the D+ pin if IOMode=1.

Bit 4: DMI. This bit is used to drive the D- pin if IOMode=1.

Bit 3: PS2PUEN. This bit controls the connection of the two internal 5 kΩ pull-up resistors to the D+ and D- pins.

Bit 2: USBPUEN. This bit controls the connection of the internal 1.5 kΩ pull-up resistor on the D+ pin.

Bit 1: DPO. This read only bit gives the state of the D+ pin.

Bit 0: DMO. This read only bit gives the state of the D- pin.

For additional information, refer to the [USBIO_CR1 register](#)

34.3.6 EPx_CNT1 Register

Address	Name	Bit 7	Bit 6	Bit 5	Bit 4	Bit 3	Bit 2	Bit 1	Bit 0	Access
0,4Eh	EP1_CNT1	Data Toggle	Data Valid						Count MSb	RW : 00
0,50h	EP2_CNT1	Data Toggle	Data Valid						Count MSb	RW : 00
0,52h	EP3_CNT1	Data Toggle	Data Valid						Count MSb	RW : 00
0,54h	EP4_CNT1	Data Toggle	Data Valid						Count MSb	RW : 00

The Endpoint Count Register 1 (EPx_CNT1) is used for configuring endpoints one through four.

Bit 7: Data Toggle. This bit selects the DATA packet's toggle state. For IN transactions, firmware must set this bit to the expected state. For OUT transactions, the hardware sets this bit to the state of the received Data Toggle bit.

Bit 6: Data Valid. This bit is used for OUT transactions only and is read only. It is cleared to '0' if CRC, bit stuffing errors,

or PID errors occur. This bit does not update for some endpoint mode settings.

Bit 0: Count MSb. This bit is the 1 MSb of a 9-bit counter. The LSb are the EPx Count[7:0] bits of the EPx_CNT register. Refer to the EPx_CNT register for more information.

For additional information, refer to the [EPx_CNT1 register](#) on page 170.

34.3.7 EPx_CNT Register

Address	Name	Bit 7	Bit 6	Bit 5	Bit 4	Bit 3	Bit 2	Bit 1	Bit 0	Access
0,4Fh	EP1_CNT	EP1 Count[7:0]								RW : 00
0,51h	EP2_CNT	EP2 Count[7:0]								RW : 00
0,53h	EP3_CNT	EP3 Count[7:0]								RW : 00
0,55h	EP4_CNT	EP4 Count[7:0]								RW : 00

The Endpoint Count Register (EPx_CNT) is used to set or report the number of bytes in a USB data transfer to the non-count endpoints.

Bits 7 to 0: EPx Count[7:0]. These bits are the 8 LSb of a 9-bit counter. The MSb is the Count MSb of the EPx_CNT1 register.

The 9-bit count indicates the number of data bytes in a transaction. For IN transactions, firmware loads the count with the number of bytes to be transmitted to the host. Valid values are 0 to 256.

The lower 8 bits of endpoint count also sets the limit for the number of bytes that will be received for an out transaction. Before an OUT transaction can be received for an endpoint, this count value must be set to the maximum number of bytes that can be received where 0x01 is 1 byte and 0xff is 255 bytes. If this count value is set to a value greater than

the number of bytes received, both the data from the USB packet and the two-byte CRC will be written to the USB's dedicated SRAM.

If the count value is less than the number of data bytes received, the SIE will mark the packet as invalid and not generate an interrupt. For example, an eight byte data packet will try to write eight data bytes and two CRC bytes. A count value of eight or greater will allow a good packet to generate an interrupt. A count value of seven or less will cause the SIE to mark the packet as bad.

Once the OUT transaction is complete, the full 9-bit count will be updated by the SIE to the actual number of data bytes received by the SIE plus two for the packet's CRC. Valid values are 2 to 258.

For additional information, refer to the [EPx_CNT register on page 171](#).

34.3.8 EP0_CR Register

Address	Name	Bit 7	Bit 6	Bit 5	Bit 4	Bit 3	Bit 2	Bit 1	Bit 0	Access
0,56h	EP0_CR	Setup Received	IN Received	OUT Received	ACK'd Transaction	Mode[3:0]				RW : 00

The Endpoint Control Register (EP0_CR) is used to configure endpoint 0.

Because both firmware and the SIE are allowed to write to the Endpoint 0 Control and Count registers, the SIE provides an interlocking mechanism to prevent accidental overwriting of data. When the SIE writes to these registers they are locked and the processor cannot write to them until after reading the EP0_CR register. Writing to this register clears the upper four bits regardless of the value written.

Bit 7: Setup Received. When set, this bit indicates a valid SETUP packet has been received and ACKed. This bit is forced HIGH from the start of the data packet phase of the SETUP transaction, until the start of the ACK packet returned by the SIE. The CPU is prevented from clearing this bit during this interval. After this interval, the bit will remain set until cleared by firmware. While this bit is set to '1', the CPU cannot write to the EP0_DRx registers. This prevents firmware from overwriting an incoming SETUP transaction before firmware has a chance to read the SETUP data. This bit is cleared by any non-locked writes to the register.

Bit 6: IN Received. When set, this bit indicates a valid IN packet has been received. This bit is updated to '1' after the

host acknowledges an IN data packet. When clear, this bit indicates either no IN has been received or that the host did not acknowledge the IN data by sending ACK handshake. It is cleared by any non-locked writes to the register.

Bit 5: OUT Received. When set, this bit indicates a valid OUT packet has been received and ACKed. This bit is updated to '1' after the last received packet in an OUT transaction. When clear, this bit indicates no OUT received. It is cleared by any non-locked writes to the register.

Bit 4: ACK'd Transaction. This bit is set whenever the SIE engages in a transaction to the register's endpoint that completes with a ACK packet. This bit is cleared by any non-locked writes to the register.

Bits 3 to 0: Mode[3:0]. The mode bits control how the USB SIE responds to traffic and how the USB SIE will change the mode of that endpoint as a result of host packets to the endpoint. Refer to the table below. Refer to the table titled "Mode Encoding for Control and Non-Control Endpoints" on page 524.

For additional information, refer to the EP0_CR register on page 172.

34.3.9 EP0_CNT Register

Address	Name	Bit 7	Bit 6	Bit 5	Bit 4	Bit 3	Bit 2	Bit 1	Bit 0	Access
0,57h	EP0_CNT	Data Toggle	Data Valid						Byte Count[3:0]	# : 00

LEGEND

#: Access is bit specific. Refer to the [Register Details](#) chapter on page 147 for additional information.

The Endpoint 0 Count Register (EP0_CNT) is used to configure endpoint 0.

Whenever the count updates from a SETUP or OUT transaction, this register locks and can not be written by the CPU. Reading the EP0_CR register unlocks this register. This prevents firmware from overwriting a status update on incoming SETUP or OUT transactions, before firmware has a chance to read the data.

Bit 7: Data Toggle. This bit selects the DATA packet's toggle state. For IN transactions, firmware must set this bit. For OUT or SETUP transactions, the SIE hardware sets this bit to the state of the received Data Toggle bit.

Bit 6: Data Valid. This bit is used for OUT transactions only. It is cleared to '0' if CRC, bit stuff, or PID errors have occurred. This bit does not update for some endpoint mode settings. This bit may be cleared by writing a zero to it when the register is not locked.

Bits 3 to 0: Byte Count[3:0]. These bits indicate the number of data bytes in a transaction. For IN transactions, firmware loads the count with the number of bytes to be transmitted to the host from the endpoint FIFO. Valid values are 0 to 8. For OUT or SETUP transactions, the count is updated by hardware to the number of data bytes received, plus two for the CRC bytes. Valid values are 2 to 10.

For additional information, refer to the [EP0_CNT register](#) on page 173.

34.3.10 EP0_DRx Register

Address	Name	Bit 7	Bit 6	Bit 5	Bit 4	Bit 3	Bit 2	Bit 1	Bit 0	Access
0,58h	EP0_DR0								Data Byte[7:0]	RW : 00
0,59h	EP0_DR1								Data Byte[7:0]	RW : 00
0,5Ah	EP0_DR2								Data Byte[7:0]	RW : 00
0,5Bh	EP0_DR3								Data Byte[7:0]	RW : 00
0,5Ch	EP0_DR4								Data Byte[7:0]	RW : 00
0,5Dh	EP0_DR5								Data Byte[7:0]	RW : 00
0,5Eh	EP0_DR6								Data Byte[7:0]	RW : 00
0,5Fh	EP0_DR7								Data Byte[7:0]	RW : 00

The Endpoint 0 Data Register (EP0_DRx) is used to read and write data to the USB control endpoint.

The EP0_DRx registers have a hardware-locking feature that prevents the CPU write when SETUP is active. The registers are locked as soon as the SETUP token is decoded and remain locked throughout the SETUP transaction and until the EP0_CR register has been read.

All other endpoint data buffers do not have this locking feature.

Bits 7 to 0: Data Byte[7:0]. These registers are shared for both transmit and receive. The count in the EP0_CNT register determines the number of bytes received or to be transferred.

For additional information, refer to the [EP0_DRx register](#) on page 174.

34.3.11 PMAx_WA Register

Address	Name	Bit 7	Bit 6	Bit 5	Bit 4	Bit 3	Bit 2	Bit 1	Bit 0	Access
1,40h	PMA0_WA	Address[7:0]								RW : 00
1,41h	PMA1_WA	Address[7:0]								RW : 00
1,42h	PMA2_WA	Address[7:0]								RW : 00
1,43h	PMA3_WA	Address[7:0]								RW : 00
1,44h	PMA4_WA	Address[7:0]								RW : 00
1,45h	PMA5_WA	Address[7:0]								RW : 00
1,46h	PMA6_WA	Address[7:0]								RW : 00
1,47h	PMA7_WA	Address[7:0]								RW : 00

The PSoC Memory Arbiter Write Address Register (PMAx_WA) is used to set the beginning SRAM address for the PMA channel. A PMAx_WA register address uses the same physical register as the PMAx_RA register address. Therefore, when the read address is changed the write address is also changed and the PMAx_RA and PMAx_WA registers always return the same value when read.

Bits 7 to 0: Address[7:0]. The value returned when this register is read depends on whether the PMA channel is being used by the USB SIE or by the M8C. In the USB case, this register will always return the beginning SRAM address for the PMA channel. In the M8C case, this register will always return the next SRAM address that will be used by the PMA channel, if a byte is written to the channel's data register (PMAx_DR) by the M8C.

For additional information, refer to the [PMAx_WA register on page 263](#).

34.3.12 PMAx_RA Register

Address	Name	Bit 7	Bit 6	Bit 5	Bit 4	Bit 3	Bit 2	Bit 1	Bit 0	Access
1,50h	PMA0_RA	Address[7:0]								RW : 00
1,51h	PMA1_RA	Address[7:0]								RW : 00
1,52h	PMA2_RA	Address[7:0]								RW : 00
1,53h	PMA3_RA	Address[7:0]								RW : 00
1,54h	PMA4_RA	Address[7:0]								RW : 00
1,55h	PMA5_RA	Address[7:0]								RW : 00
1,56h	PMA6_RA	Address[7:0]								RW : 00
1,57h	PMA7_RA	Address[7:0]								RW : 00

The PSoC Memory Arbiter Read Address Register (PMAx_RA) is used to set the beginning address for the PMA channel. A PMAx_RA register address uses the same physical register as the PMAx_WA register address. Therefore, when the read address is changed the write address is also changed and the PMAx_WA and PMAx_RA registers always return the same value when read.

Bits 7 to 0: Address[7:0]. The value returned when this register is read depends on whether the PMA channel is being used by the USB SIE or by the M8C. In the USB case, this register will always return the beginning SRAM address for the PMA channel. In the M8C case, this register will always return the next SRAM address that will be used by the PMA channel, if a byte is read from the channel's data register (PMAx_DR) by the M8C.

For additional information, refer to the [PMAx_RA register on page 264](#).

When a PMAx_RA register is written, the address is stored and the value of the corresponding SRAM address is loaded into the channel's PMAx_DR. Therefore, this register should only be written after valid data has been stored in SRAM for the channel.

34.3.13 USB_CR1 Register

Address	Name	Bit 7	Bit 6	Bit 5	Bit 4	Bit 3	Bit 2	Bit 1	Bit 0	Access
1,C1h	USB_CR1						BusActivity	EnableLock	RegEnable	RW : 00

The USB Control Register 1 (USB_CR1) is used to configure the internal regulator and the oscillator tuning capability.

Bit 2: BusActivity. The Bus Activity bit is a “sticky” bit that detects any non-idle USB event that has occurred on the USB bus. Once set to High by the SIE to indicate the bus activity, this bit retains its logical High value until firmware clears it. Writing a ‘0’ to this bit clears it; writing a ‘1’ preserves its value.

Bit 1: EnableLock. Set this bit to turn on the automatic frequency locking of the internal oscillator to USB traffic. Unless an external clock is being provided, this bit should remain set for proper USB operation.

Bit 0: RegEnable. This bit controls the operation of the internal USB regulator. For applications with PSoC supply voltages in the 5V range, set this bit high to enable the internal regulator. For device supply voltage in the 3.3V range, clear this bit to connect the transceiver directly to the supply.

For additional information, refer to the [USB_CR1 register on page 281](#).

34.3.14 EPx_CR0 Register

Address	Name	Bit 7	Bit 6	Bit 5	Bit 4	Bit 3	Bit 2	Bit 1	Bit 0	Access
1,C4h	EP1_CR0	Stall		NAK Int Enable	ACK'd Transaction	Mode[3:0]				RW : 00
1,C5h	EP2_CR0	Stall		NAK Int Enable	ACK'd Transaction	Mode[3:0]				RW : 00
1,C6h	EP3_CR0	Stall		NAK Int Enable	ACK'd Transaction	Mode[3:0]				RW : 00
1,C7h	EP4_CR0	Stall		NAK Int Enable	ACK'd Transaction	Mode[3:0]				RW : 00

The Endpoint Control Register 0 (EPx_CR0) is used for status and configuration of the non-control endpoints.

Bit 7: Stall. When this bit is set, the SIE stalls an OUT packet if the Mode bits are set to ACK-OUT. The SIE stalls an IN packet if the mode bits are set to ACK-IN. This bit must be clear for all other modes.

Bit 5: NAK Int Enable. When set, this bit causes an endpoint interrupt to be generated even when a transfer completes with a NAK.

Bit 4: ACK'd Transaction. The ACK'd transaction bit is set whenever the SIE engages in a transaction to the register's endpoint that completes with an ACK packet. This bit is cleared by any writes to the register.

Bits 3 to 0: Mode[3:0]. The mode controls how the USB SIE responds to traffic and how the USB SIE changes the mode of that endpoint as a result of host packets to the endpoint. Refer to the table titled “[Mode Encoding for Control and Non-Control Endpoints](#)” on page 524.

For additional information, refer to the [EPx_CR0 register on page 282](#).

34.3.15 IMO_TR1 Register

Address	Name	Bit 7	Bit 6	Bit 5	Bit 4	Bit 3	Bit 2	Bit 1	Bit 0	Access
1,EEh	IMO_TR1						Fine Trim[2:0]			RW : 00

It is strongly recommended that the user not alter this register's values. The Internal Main Oscillator Trim Register 1 (IMO_TR1) is used to fine tune the IMO frequency.

For information on the other IMO trim register (IMO_TR) see the “[Register Definitions](#)” on page 115 in the Internal Main Oscillator chapter or refer to the [IMO_TR register](#) on page 298 in the Register Details chapter.

Bits 2 to 0: Fine Trim[2:0]. These bits provide a fine tuning capability to the IMO trim. These are only used in the CY8C24x94 device which has an IMO with 11 bits of offset trim. These three bits are the 3 LSB of this trim with the IMO_TR register supplying the 8 MSb.

For additional information, refer to the [IMO_TR1 register](#) on page 302.

34.3.16 IMO_TR2 Register

Address	Name	Bit 7	Bit 6	Bit 5	Bit 4	Bit 3	Bit 2	Bit 1	Bit 0	Access
1,EFh	IMO_TR2				Gain Trim[5:0]					RW : 30

It is strongly recommended that the user not alter this register's values. The Internal Main Oscillator Trim Register 2 (IMO_TR2) is used to set the gain of the IMO.

For information on the other IMO trim register (IMO_TR) see the “[Register Definitions](#)” on page 115 in the Internal Main

Oscillator chapter or refer to the [IMO_TR register](#) on page 298 in the Register Details chapter.

Bits 5 to 0: Gain Trim[5:0]. These bits affect the step size of the IMO trim in the CY8C24x94 device only.

35. nvSRAM



This chapter explains nvSRAM and its functionality.

35.1 Architectural Description

The Cypress nvSRAM is a fast static RAM, with a nonvolatile element in each memory cell. The embedded nonvolatile elements incorporate QuantumTrap technology, producing the world's most reliable nonvolatile memory. The SRAM provides infinite read and write cycles, while independent nonvolatile data resides in the highly reliable QuantumTrap

cell. Data transfers from the SRAM to the nonvolatile elements (the STORE operation) takes place automatically at power down. On power up, data is restored to the SRAM (the RECALL operation) from the nonvolatile memory. Both the STORE and RECALL operations are available under software control.

Figure 35-1. PSoC NV Block Diagram

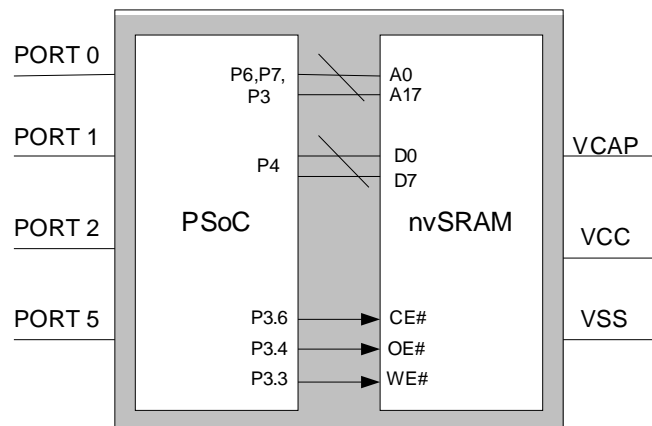

The nvSRAM address, data and control lines are internally connected to the PSoC. The address lines of the nvSRAM are connected to the PSoC ports 6, 7, P3.0 and P3.2 and the data lines are connected to port 4. The nvSRAM is made up of two functional components paired in the same physical cell, the SRAM memory cell and a nonvolatile QuantumTrap cell. The SRAM memory cell operates as a standard fast static RAM. Data in the SRAM is transferred to the nonvolatile cell (the STORE operation), or from the nonvolatile cell to the SRAM (the RECALL operation). Using this unique architecture, all cells are stored and recalled in parallel. During the STORE and RECALL operations, SRAM read and write operations are inhibited. The nvSRAM supports infinite reads and writes similar to a typical SRAM. In addition, it provides infinite RECALL operations from the nonvolatile cells and up to 200K STORE operations.

35.2 Application Description

35.2.1 SRAM Read and SRAM Write

The nvSRAM is a fast static RAM in power on condition. The reads and writes to the SRAM are initiated by the registers in the PSoC NV.

35.2.1.1 AutoStore Operation

The nvSRAM stores data to the nonvolatile memory using one of these storage operations: Software Store activated by an address sequence and AutoStore on device power down. The AutoStore operation is a unique feature of QuantumTrap technology and is enabled by default. During a normal operation, the device draws current from VCC to charge

a capacitor connected to the VCAP pin. This stored charge is used by the chip to perform a single STORE operation. If the voltage on the VCC pin drops below VSWITCH, the part automatically disconnects the VCAP pin from VCC. A STORE operation is initiated with power provided by the VCAP capacitor.

For 256 KBytes of nvSRAM, place the VCAP value in the range $61\mu\text{F} < \text{VCAP} < 82\mu\text{F}$.

To reduce unnecessary nonvolatile stores, AutoStore and hardware store operations are ignored unless at least one write operation takes place since the most recent STORE or RECALL cycle. Software initiated STORE cycles are performed regardless of whether a write operation has taken place.

35.2.1.2 Hardware RECALL (Power Up)

During power up or after any low power condition ($V_{CC} < V_{SWITCH}$), an internal RECALL request is latched. When V_{CC} again exceeds the sense voltage of VSWITCH, a RECALL cycle is automatically initiated and takes power up RECALL Duration tHRECALL of 20 msec (max) to complete.

VCC - supply voltage to the PSoC NV

VSWITCH - switching voltage where nvSRAM switches from Vcc to backup power 2.65 V

35.2.1.3 Software STORE

Transfer data from the SRAM to the nonvolatile memory with a software address sequence. The software STORE cycle is initiated by executing sequential read cycles from six specific address locations in exact order. During the STORE cycle an erase of the previous nonvolatile data is first performed, followed by a program of the nonvolatile elements. After a STORE cycle is initiated, further input and output operations are disabled until the cycle is completed.

Because a sequence of READs from specific addresses is used for STORE initiation, it is important that no other read or write accesses intervene in the sequence, or the sequence is aborted and no STORE or RECALL takes place.

To initiate the software STORE cycle, perform this read sequence.

1. Read Address 0x028EC0 Valid READ
2. Read Address 0x017139 Valid READ
3. Read Address 0x00F801 Valid READ
4. Read Address 0x0307F8 Valid READ
5. Read Address 0x0381F8 Valid READ
6. Read Address 0x007E01 Initiate STORE Cycle

After the STORE cycle duration tSTORE 15 msec (max) is fulfilled, the SRAM is activated again for the read and write operation.

35.2.1.4 Software RECALL

A software RECALL cycle is initiated with a sequence of read operations in a manner similar to the software STORE initiation. To initiate the RECALL cycle, the following sequence of read operations must be performed. Internally, RECALL is a two step procedure. First, the SRAM data

is cleared; then, the nonvolatile information is transferred into the SRAM cells. After the software RECALL Duration (tRECALL), the SRAM is again ready for read and write operations. The RECALL operation does not alter the data in the nonvolatile elements.

1. Read Address 0x028EC0 Valid READ
2. Read Address 0x017139 Valid READ
3. Read Address 0x00F801 Valid READ
4. Read Address 0x0307F8 Valid READ
5. Read Address 0x0381F8 Valid READ
6. Read Address 0x02C618 Initiate RECALL Cycle

35.2.1.5 Preventing AutoStore

The AutoStore function is disabled by initiating an AutoStore disable sequence. A sequence of read operations is performed in a manner similar to the software STORE initiation. To initiate the AutoStore disable sequence, the following sequence of read operations must be performed:

1. Read Address 0x028EC0 Valid READ
2. Read Address 0x017139 Valid READ
3. Read Address 0x00F801 Valid READ
4. Read Address 0x0307F8 Valid READ
5. Read Address 0x0381F8 Valid READ
6. Read Address 0x005A29 AutoStore Disable

The AutoStore is reenabled by initiating an AutoStore enable sequence. A sequence of read operations is performed in a manner similar to the software RECALL initiation. To initiate the AutoStore enable sequence, the following sequence of read operations must be performed:

1. Read Address 0x028EC0 Valid READ
2. Read Address 0x017139 Valid READ
3. Read Address 0x00F801 Valid READ
4. Read Address 0x0307F8 Valid READ
5. Read Address 0x0381F8 Valid READ
6. Read Address 0x025A30 Autostore Enable

If the AutoStore function is disabled or re-enabled, a manual STORE operation (hardware or software) must be issued to save the AutoStore state through subsequent power down cycles.

Section G: Glossary



The Glossary section explains the terminology used in this technical reference manual. Glossary terms are characterized in **bold, italic font** throughout the text of this manual.

A

<i>accumulator</i>	In a CPU, a register in which intermediate results are stored. Without an accumulator, it would be necessary to write the result of each calculation (addition, subtraction, shift, and so on.) to main memory and read them back. Access to main memory is slower than access to the accumulator, which usually has direct paths to and from the arithmetic and logic unit (ALU).
<i>active high</i>	<ol style="list-style-type: none">1. A logic signal having its asserted state as the logic 1 state.2. A logic signal having the logic 1 state as the higher voltage of the two states.
<i>active low</i>	<ol style="list-style-type: none">1. A logic signal having its asserted state as the logic 0 state.2. A logic signal having its logic 1 state as the lower voltage of the two states: inverted logic.
<i>address</i>	The label or number identifying the memory location (RAM, ROM, or register) where a unit of information is stored.
<i>algorithm</i>	A procedure for solving a mathematical problem in a finite number of steps that frequently involve repetition of an operation.
<i>ambient temperature</i>	The temperature of the air in a designated area, particularly the area surrounding the PSoC device.
<i>analog</i>	See <i>analog signals</i> .
<i>analog blocks</i>	The basic programmable opamp circuits. These are SC (switched capacitor) and CT (continuous time) blocks. These blocks can be interconnected to provide ADCs, DACs, multi-pole filters, gain stages, and much more.
<i>analog output</i>	An output that is capable of driving any voltage between the supply rails, instead of just a logic 1 or logic 0.
<i>analog signals</i>	A signal represented in a continuous form with respect to continuous times, as contrasted with a digital signal represented in a discrete (discontinuous) form in a sequence of time.
<i>analog-to-digital (ADC)</i>	A device that changes an analog signal to a digital signal of corresponding magnitude. Typically, an ADC converts a voltage to a digital number. The <i>digital-to-analog (DAC)</i> converter performs the reverse operation.

AND	See Boolean Algebra .
API (Application Programming Interface)	A series of software routines that comprise an interface between a computer application and lower level services and functions (for example, user modules and libraries). APIs serve as building blocks for programmers that create software applications.
array	An array, also known as a vector or list, is one of the simplest data structures in computer programming. Arrays hold a fixed number of equally-sized data elements, generally of the same data type. Individual elements are accessed by index using a consecutive range of integers, as opposed to an associative array. Most high level programming languages have arrays as a built-in data type. Some arrays are multi-dimensional, meaning they are indexed by a fixed number of integers; for example, by a group of two integers. One- and two-dimensional arrays are the most common. Also, an array can be a group of capacitors or resistors connected in some common form.
assembly	A symbolic representation of the machine language of a specific processor. Assembly language is converted to machine code by an assembler. Usually, each line of assembly code produces one machine instruction, though the use of macros is common. Assembly languages are considered low level languages; where as C is considered a high level language.
asynchronous	A signal whose data is acknowledged or acted upon immediately, irrespective of any clock signal.
attenuation	The decrease in intensity of a signal as a result of absorption of energy and of scattering out of the path to the detector, but not including the reduction due to geometric spreading. Attenuation is usually expressed in dB.

B

bandgap reference	A stable voltage reference design that matches the positive temperature coefficient of V_T with the negative temperature coefficient of V_{BE} , to produce a zero temperature coefficient (ideally) reference.
bandwidth	<ol style="list-style-type: none"> 1. The frequency range of a message or information processing system measured in hertz. 2. The width of the spectral region over which an amplifier (or absorber) has substantial gain (or loss); it is sometimes represented more specifically as, for example, full width at half maximum.
bias	<ol style="list-style-type: none"> 1. A systematic deviation of a value from a reference value. 2. The amount by which the average of a set of values departs from a reference value. 3. The electrical, mechanical, magnetic, or other force (field) applied to a device to establish a reference level to operate the device.
bias current	The constant low level DC current that is used to produce a stable operation in amplifiers. This current can sometimes be changed to alter the bandwidth of an amplifier.
binary	The name for the base 2 numbering system. The most common numbering system is the base 10 numbering system. The base of a numbering system indicates the number of values that may exist for a particular positioning within a number for that system. For example, in base 2, binary, each position may have one of two values (0 or 1). In the base 10, decimal, numbering system, each position may have one of ten values (0, 1, 2, 3, 4, 5, 6, 7, 8, and 9).

bit	A single digit of a binary number. Therefore, a bit may only have a value of '0' or '1'. A group of 8 bits is called a byte. Because the PSoC's M8C is an 8-bit microcontroller, the PSoC's native data chunk size is a byte.
bit rate (BR)	The number of bits occurring per unit of time in a bit stream, usually expressed in bits per second (bps).
block	<ol style="list-style-type: none">1. A functional unit that performs a single function, such as an oscillator.2. A functional unit that may be configured to perform one of several functions, such as a digital PSoC block or an analog PSoC block.
Boolean Algebra	<p>In mathematics and computer science, Boolean algebras or Boolean lattices, are algebraic structures which "capture the essence" of the logical operations AND, OR and NOT as well as the set theoretic operations union, intersection, and complement. Boolean algebra also defines a set of theorems that describe how Boolean equations can be manipulated. For example, these theorems are used to simplify Boolean equations, which will reduce the number of logic elements needed to implement the equation.</p> <p>The operators of Boolean algebra may be represented in various ways. Often they are simply written as AND, OR, and NOT. In describing circuits, NAND (NOT AND), NOR (NOT OR), XNOR (exclusive NOT OR), and XOR (exclusive OR) may also be used. Mathematicians often use + (for example, A+B) for OR and \cdot for AND (for example, A*B) (since in some ways those operations are analogous to addition and multiplication in other algebraic structures) and represent NOT by a line drawn above the expression being negated (for example, $\sim A$, A_{\sim}, !A).</p>
break-before-make	The elements involved go through a disconnected state entering ("break") before the new connected state ("make").
broadcast net	A signal that is routed throughout the microcontroller and is accessible by many blocks or systems.
buffer	<ol style="list-style-type: none">1. A storage area for data that is used to compensate for a speed difference, when transferring data from one device to another. Usually refers to an area reserved for IO operations, into which data is read, or from which data is written.2. A portion of memory set aside to store data, often before it is sent to an external device or as it is received from an external device.3. An amplifier used to lower the output impedance of a system.
bus	<ol style="list-style-type: none">1. A named connection of nets. Bundling nets together in a bus makes it easier to route nets with similar routing patterns.2. A set of signals performing a common function and carrying similar data. Typically represented using vector notation; for example, address[7:0].3. One or more conductors that serve as a common connection for a group of related devices.
byte	A digital storage unit consisting of 8 bits.

C

C	A high level programming language.
capacitance	A measure of the ability of two adjacent conductors, separated by an insulator, to hold a charge when a voltage differential is applied between them. Capacitance is measured in units of Farads.

capture	To extract information automatically through the use of software or hardware, as opposed to hand-entering of data into a computer file.
chaining	Connecting two or more 8-bit digital blocks to form 16-, 24-, and even 32-bit functions. Chaining allows certain signals such as Compare, Carry, Enable, Capture, and Gate to be produced from one block to another.
checksum	The checksum of a set of data is generated by adding the value of each data word to a sum. The actual checksum can simply be the result sum or a value that must be added to the sum to generate a pre-determined value.
clear	To force a bit/register to a value of logic '0'.
clock	The device that generates a periodic signal with a fixed frequency and duty cycle. A clock is sometimes used to synchronize different logic blocks.
clock generator	A circuit that is used to generate a clock signal.
CMOS	The logic gates constructed using MOS transistors connected in a complementary manner. CMOS is an acronym for complementary metal-oxide semiconductor.
comparator	An electronic circuit that produces an output voltage or current whenever two input levels simultaneously satisfy predetermined amplitude requirements.
compiler	A program that translates a high level language, such as C, into machine language.
configuration	In a computer system, an arrangement of functional units according to their nature, number, and chief characteristics. Configuration pertains to hardware, software, firmware, and documentation. The configuration will affect system performance.
configuration space	In PSoC devices, the register space accessed when the XIO bit, in the CPU_F register, is set to '1'.
crowbar	A type of over-voltage protection that rapidly places a low resistance shunt (typically an SCR) from the signal to one of the power supply rails, when the output voltage exceeds a predetermined value.
crystal oscillator	An oscillator in which the frequency is controlled by a piezoelectric crystal. Typically a piezoelectric crystal is less sensitive to ambient temperature than other circuit components.
cyclic redundancy check (CRC)	A calculation used to detect errors in data communications, typically performed using a linear feedback shift register. Similar calculations may be used for a variety of other purposes such as data compression.

D

data bus	A bi-directional set of signals used by a computer to convey information from a memory location to the central processing unit and vice versa. More generally, a set of signals used to convey data between digital functions.
data stream	A sequence of digitally encoded signals used to represent information in transmission.
data transmission	The sending of data from one place to another by means of signals over a channel.

debugger	A hardware and software system that allows the user to analyze the operation of the system under development. A debugger usually allows the developer to step through the firmware one step at a time, set break points, and analyze memory.
dead band	A period of time when neither of two or more signals are in their active state or in transition.
decimal	A base-10 numbering system, which uses the symbols 0, 1, 2, 3, 4, 5, 6, 7, 8 and 9 (called digits) together with the decimal point and the sign symbols + (plus) and - (minus) to represent numbers.
default value	Pertaining to the pre-defined initial, original, or specific setting, condition, value, or action a system will assume, use, or take in the absence of instructions from the user.
device	The device referred to in this manual is the PSoC chip, unless otherwise specified.
die	An unpackaged integrated circuit (IC), normally cut from a wafer.
digital	A signal or function, the amplitude of which is characterized by one of two discrete values: '0' or '1'.
digital blocks	The 8-bit logic blocks that can act as a counter, timer, serial receiver, serial transmitter, CRC generator, pseudo-random number generator, or SPI.
digital logic	A methodology for dealing with expressions containing two-state variables that describe the behavior of a circuit or system.
digital-to-analog (DAC)	A device that changes a digital signal to an analog signal of corresponding magnitude. The analog-to-digital (ADC) converter performs the reverse operation.
direct access	The capability to obtain data from a storage device, or to enter data into a storage device, in a sequence independent of their relative positions by means of addresses that indicate the physical location of the data.
duty cycle	The relationship of a clock period high time to its low time , expressed as a percent.

E

emulator	Duplicates (provides an emulation of) the functions of one system with a different system, so that the second system appears to behave like the first system.
External Reset (XRES)	An active high signal that is driven into the PSoC device. It causes all operation of the CPU and blocks to stop and return to a pre-defined state.

F

falling edge	A transition from a logic 1 to a logic 0. Also known as a negative edge.
feedback	The return of a portion of the output, or processed portion of the output, of a (usually active) device to the input.
filter	A device or process by which certain frequency components of a signal are attenuated.

firmware	The software that is embedded in a hardware device and executed by the CPU. The software may be executed by the end user, but it may not be modified.
flag	Any of various types of indicators used for identification of a condition or event (for example, a character that signals the termination of a transmission).
Flash	An electrically programmable and erasable, non- volatile technology that provides users with the programmability and data storage of EPROMs, plus in-system erasability. Non-volatile means that the data is retained when power is off.
Flash bank	A group of Flash ROM blocks where Flash block numbers always begin with '0' in an individual Flash bank. A Flash bank also has its own block level protection information.
Flash block	The smallest amount of Flash ROM space that may be programmed at one time and the smallest amount of Flash space that may be protected. A Flash block holds 64 bytes.
flip-flop	A device having two stable states and two input terminals (or types of input signals) each of which corresponds with one of the two states. The circuit remains in either state until it is made to change to the other state by application of the corresponding signal.
frequency	The number of cycles or events per unit of time, for a periodic function.

G

gain	The ratio of output current, voltage, or power to input current, voltage, or power, respectively. Gain is usually expressed in dB.
gate	<ol style="list-style-type: none">1. A device having one output channel and one or more input channels, such that the output channel state is completely determined by the input channel states, except during switching transients.2. One of many types of combinational logic elements having at least two inputs (for example, AND, OR, NAND, and NOR (also see Boolean Algebra)).
ground	<ol style="list-style-type: none">1. The electrical neutral line having the same potential as the surrounding earth.2. The negative side of DC power supply.3. The reference point for an electrical system.4. The conducting paths between an electric circuit or equipment and the earth, or some conducting body serving in place of the earth.

H

hardware	A comprehensive term for all of the physical parts of a computer or embedded system, as distinguished from the data it contains or operates on, and the software that provides instructions for the hardware to accomplish tasks.
hardware reset	A reset that is caused by a circuit, such as a POR, watchdog reset, or external reset. A hardware reset restores the state of the device as it was when it was first powered up. Therefore, all registers are set to the POR value as indicated in register tables throughout this document.

hexadecimal

A base 16 numeral system (often abbreviated and called hex), usually written using the symbols 0-9 and A-F. It is a useful system in computers because there is an easy mapping from four bits to a single hex digit. Thus, one can represent every byte as two consecutive hexadecimal digits. Compare the binary, hex, and decimal representations:

bin	=	hex	=	dec
0000b	=	0x0	=	0
0001b	=	0x1	=	1
0010b	=	0x2	=	2
...				
1001b	=	0x9	=	9
1010b	=	0xA	=	10
1011b	=	0xB	=	11
...				
1111b	=	0xF	=	15

So the decimal numeral 79 whose binary representation is 0100 1111b can be written as 4Fh in hexadecimal (0x4F).

high time

The amount of time the signal has a value of '1' in one period, for a periodic digital signal.

I

I²C

A two-wire serial computer bus by Philips Semiconductors (now NXP Semiconductors). I²C is an Inter-Integrated Circuit. It is used to connect low-speed peripherals in an embedded system. The original system was created in the early 1980s as a battery control interface, but it was later used as a simple internal bus system for building control electronics. I²C uses only two bi-directional pins, clock and data, both running at +5V and pulled high with resistors. The bus operates at 100 kbits/second in standard mode and 400 kbits/second in fast mode.

ICE

The in-circuit emulator that allows users to test the project in a hardware environment, while viewing the debugging device activity in a software environment (PSoC Designer).

idle state

A condition that exists whenever user messages are not being transmitted, but the service is immediately available for use.

impedance

1. The resistance to the flow of current caused by resistive, capacitive, or inductive devices in a circuit.
2. The total passive opposition offered to the flow of electric current. Note the impedance is determined by the particular combination of resistance, inductive reactance, and capacitive reactance in a given circuit.

input

A point that accepts data, in a device, process, or channel.

input/output (IO)

A device that introduces data into or extracts data from a system.

instruction

An expression that specifies one operation and identifies its operands, if any, in a programming language such as C or assembly.

integrated circuit (IC)

A device in which components such as resistors, capacitors, diodes, and **transistors** are formed on the surface of a single piece of semiconductor.

interface

The means by which two systems or devices are connected and interact with each other.

interrupt	A suspension of a process, such as the execution of a computer program, caused by an event external to that process, and performed in such a way that the process can be resumed.
interrupt service routine (ISR)	A block of code that normal code execution is diverted to when the M8C receives a hardware interrupt. Many interrupt sources may each exist with its own priority and individual ISR code block. Each ISR code block ends with the RETI instruction, returning the device to the point in the program where it left normal program execution.

J

jitter	<ol style="list-style-type: none"> 1. A misplacement of the timing of a transition from its ideal position. A typical form of corruption that occurs on serial data streams. 2. The abrupt and unwanted variations of one or more signal characteristics, such as the interval between successive pulses, the amplitude of successive cycles, or the frequency or phase of successive cycles.
---------------	---

K

keeper	A circuit that holds a signal to the last driven value, even when the signal becomes un-driven.
---------------	---

L

latency	The time or delay that it takes for a signal to pass through a given circuit or network.
least significant bit (LSb)	The binary digit, or bit, in a binary number that represents the least significant value (typically the right-hand bit). The bit versus byte distinction is made by using a lower case "b" for bit in LSb.
least significant byte (LSB)	The byte in a multi-byte word that represents the least significant values (typically the right-hand byte). The byte versus bit distinction is made by using an upper case "B" for byte in LSB.
Linear Feedback Shift Register (LFSR)	A shift register whose data input is generated as an XOR of two or more elements in the register chain.
load	The electrical demand of a process expressed as power (watts), current (amps), or resistance (ohms).
logic function	A mathematical function that performs a digital operation on digital data and returns a digital value.
look-up table (LUT)	A logic block that implements several logic functions. The logic function is selected by means of select lines and is applied to the inputs of the block. For example: A 2 input LUT with 4 select lines can be used to perform any one of 16 logic functions on the two inputs resulting in a single logic output. The LUT is a combinational device; therefore, the input/output relationship is continuous, that is, not sampled.
low time	The amount of time the signal has a value of '0' in one period, for a periodic digital signal.
low voltage detect (LVD)	A circuit that senses V _{dd} and provides an interrupt to the system when V _{dd} falls below a selected threshold.

M

M8C	An 8-bit Harvard Architecture microprocessor. The microprocessor coordinates all activity inside a PSoC by interfacing to the Flash, SRAM, and register space.
macro	A programming language macro is an abstraction, whereby a certain textual pattern is replaced according to a defined set of rules. The interpreter or compiler automatically replaces the macro instance with the macro contents when an instance of the macro is encountered. Therefore, if a macro is used 5 times and the macro definition required 10 bytes of code space, 50 bytes of code space will be needed in total.
mask	<ol style="list-style-type: none">1. To obscure, hide, or otherwise prevent information from being derived from a signal. It is usually the result of interaction with another signal, such as noise, static, jamming, or other forms of interference.2. A pattern of bits that can be used to retain or suppress segments of another pattern of bits, in computing and data processing systems.
master device	A device that controls the timing for data exchanges between two devices. Or when devices are cascaded in width, the master device is the one that controls the timing for data exchanges between the cascaded devices and an external interface. The controlled device is called the slave device .
microcontroller	An integrated circuit chip that is designed primarily for control systems and products. In addition to a CPU, a microcontroller typically includes memory, timing circuits, and IO circuitry. The reason for this is to permit the realization of a controller with a minimal quantity of chips, thus achieving maximal possible miniaturization. This in turn, will reduce the volume and the cost of the controller. The microcontroller is normally not used for general-purpose computation as is a microprocessor.
mixed-signal	The reference to a circuit containing both analog and digital techniques and components.
mnemonic	A tool intended to assist the memory. Mnemonics rely on not only repetition to remember facts, but also on creating associations between easy-to-remember constructs and lists of data. A two to four character string representing a microprocessor instruction.
mode	A distinct method of operation for software or hardware. For example, the Digital PSoC block may be in either counter mode or timer mode.
modulation	A range of techniques for encoding information on a carrier signal, typically a sine-wave signal. A device that performs modulation is known as a modulator.
Modulator	A device that imposes a signal on a carrier.
MOS	An acronym for metal-oxide semiconductor.
most significant bit (MSb)	The binary digit, or bit, in a binary number that represents the most significant value (typically the left-hand bit). The bit versus byte distinction is made by using a lower case “b” for bit in MSb.
most significant byte (MSB)	The byte in a multi-byte word that represents the most significant values (typically the left-hand byte). The byte versus bit distinction is made by using an upper case “B” for byte in MSB.
multiplexer (mux)	<ol style="list-style-type: none">1. A logic function that uses a binary value, or address, to select between a number of inputs and conveys the data from the selected input to the output.2. A technique which allows different input (or output) signals to use the same lines at different times, controlled by an external signal. Multiplexing is used to save on wiring and IO ports.

N

NAND	See Boolean Algebra .
negative edge	A transition from a logic 1 to a logic 0. Also known as a falling edge.
net	The routing between devices.
nibble	A group of four bits, which is one-half of a byte.
noise	<ol style="list-style-type: none"> 1. A disturbance that affects a signal and that may distort the information carried by the signal. 2. The random variations of one or more characteristics of any entity such as voltage, current, or data.
NOR	See Boolean Algebra .
NOT	See Boolean Algebra .
nvSRAM	An acronym for NonVolatile Static Random Access Memory. A memory device that acts as an SRAM during power on condition and secures data to its nonvolatile memory during power down.

O

OR	See Boolean Algebra .
oscillator	A circuit that may be crystal controlled and is used to generate a clock frequency.
output	The electrical signal or signals which are produced by an analog or digital block.

P

parallel	The means of communication in which digital data is sent multiple bits at a time, with each simultaneous bit being sent over a separate line.
parameter	Characteristics for a given block that have either been characterized or may be defined by the designer.
parameter block	A location in memory where parameters for the SSC instruction are placed prior to execution.
parity	A technique for testing transmitting data. Typically, a binary digit is added to the data to make the sum of all the digits of the binary data either always even (even parity) or always odd (odd parity).
path	<ol style="list-style-type: none"> 1. The logical sequence of instructions executed by a computer. 2. The flow of an electrical signal through a circuit.
pending interrupts	An interrupt that has been triggered but has not been serviced, either because the processor is busy servicing another interrupt or global interrupts are disabled.

phase	The relationship between two signals, usually the same frequency, that determines the delay between them. This delay between signals is either measured by time or angle (degrees).
Phase-Locked Loop (PLL)	An electronic circuit that controls an oscillator so that it maintains a constant phase angle relative to a reference signal.
pin	A terminal on a hardware component. Also called lead.
pinouts	The pin number assignment: the relation between the logical inputs and outputs of the PSoC device and their physical counterparts in the printed circuit board (PCB) package. Pinouts will involve pin numbers as a link between schematic and PCB design (both being computer generated files) and may also involve pin names.
port	A group of pins, usually eight.
positive edge	A transition from a logic 0 to a logic 1. Also known as a rising edge.
posted interrupts	An interrupt that has been detected by the hardware but may or may not be enabled by its mask bit. Posted interrupts that are not masked become pending interrupts.
Power On Reset (POR)	A circuit that forces the PSoC device to reset when the voltage is below a pre-set level. This is one type of hardware reset .
program counter	The instruction pointer (also called the program counter) is a register in a computer processor that indicates where in memory the CPU is executing instructions. Depending on the details of the particular machine, it holds either the address of the instruction being executed, or the address of the next instruction to be executed.
protocol	A set of rules. Particularly the rules that govern networked communications.
PSoC	Cypress Semiconductor's PSoC® is a registered trademark and Programmable System-on-Chip™ is a trademark of Cypress.
PSoC blocks	See analog blocks and digital blocks .
PSoC Designer	The software for Cypress' Programmable System-on-Chip technology.
pulse	A rapid change in some characteristic of a signal (for example, phase or frequency), from a baseline value to a higher or lower value, followed by a rapid return to the baseline value.
pulse width modulator (PWM)	An output in the form of duty cycle which varies as a function of the applied measurand.

R

RAM	An acronym for random access memory. A data-storage device from which data can be read out and new data can be written in.
register	A storage device with a specific capacity, such as a bit or byte.
reset	A means of bringing a system back to a know state. See hardware reset and software reset .
resistance	The resistance to the flow of electric current measured in ohms for a conductor.

revision ID	A unique identifier of the PSoC device.
ripple divider	An asynchronous ripple counter constructed of flip-flops. The clock is fed to the first stage of the counter. An n-bit binary counter consisting of n flip-flops that can count in binary from 0 to $2^n - 1$.
rising edge	See positive edge .
ROM	An acronym for read only memory. A data-storage device from which data can be read out, but new data cannot be written in.
routine	A block of code, called by another block of code, that may have some general or frequent use.
routing	Physically connecting objects in a design according to design rules set in the reference library.
runt pulses	In digital circuits, narrow pulses that, due to non-zero rise and fall times of the signal, do not reach a valid high or low level. For example, a runt pulse may occur when switching between asynchronous clocks or as the result of a race condition in which a signal takes two separate paths through a circuit. These race conditions may have different delays and are then recombined to form a glitch or when the output of a flip-flop becomes metastable.

S

sampling	The process of converting an analog signal into a series of digital values or reversed.
schematic	A diagram, drawing, or sketch that details the elements of a system, such as the elements of an electrical circuit or the elements of a logic diagram for a computer.
seed value	An initial value loaded into a linear feedback shift register or random number generator.
serial	<ol style="list-style-type: none"> 1. Pertaining to a process in which all events occur one after the other. 2. Pertaining to the sequential or consecutive occurrence of two or more related activities in a single device or channel.
set	To force a bit/register to a value of logic 1.
settling time	The time it takes for an output signal or value to stabilize after the input has changed from one value to another.
shift	The movement of each bit in a word one position to either the left or right. For example, if the hex value 0x24 is shifted one place to the left, it becomes 0x48. If the hex value 0x24 is shifted one place to the right, it becomes 0x12.
shift register	A memory storage device that sequentially shifts a word either left or right to output a stream of serial data.
sign bit	The most significant binary digit, or bit, of a signed binary number. If set to a logic 1, this bit represents a negative quantity.
signal	A detectable transmitted energy that can be used to carry information. As applied to electronics, any transmitted electrical impulse.
silicon ID	A unique identifier of the PSoC silicon.

skew	The difference in arrival time of bits transmitted at the same time, in parallel transmission.
slave device	A device that allows another device to control the timing for data exchanges between two devices. Or when devices are cascaded in width, the slave device is the one that allows another device to control the timing of data exchanges between the cascaded devices and an external interface. The controlling device is called the master device.
software	A set of computer programs, procedures, and associated documentation concerned with the operation of a data processing system (for example, compilers, library routines, manuals, and circuit diagrams). Software is often written first as source code, and then converted to a binary format that is specific to the device on which the code will be executed.
software reset	A partial reset executed by software to bring part of the system back to a known state. A software reset will restore the M8C to a known state but not PSoC blocks, systems, peripherals, or registers. For a software reset, the CPU registers (CPU_A, CPU_F, CPU_PC, CPU_SP, and CPU_X) are set to 0x00. Therefore, code execution will begin at Flash address 0x0000.
SRAM	An acronym for static random access memory. A memory device allowing users to store and retrieve data at a high rate of speed. The term static is used because, once a value has been loaded into an SRAM cell, it will remain unchanged until it is explicitly altered or until power is removed from the device.
SROM	An acronym for supervisory read only memory. The SROM holds code that is used to boot the device, calibrate circuitry, and perform Flash operations. The functions of the SROM may be accessed in normal user code, operating from Flash.
stack	A stack is a data structure that works on the principle of Last In First Out (LIFO). This means that the last item put on the stack is the first item that can be taken off.
stack pointer	A stack may be represented in a computer's inside blocks of memory cells, with the bottom at a fixed location and a variable stack pointer to the current top cell.
state machine	The actual implementation (in hardware or software) of a function that can be considered to consist of a set of states through which it sequences.
sticky	A bit in a register that maintains its value past the time of the event that caused its transition, has passed.
stop bit	A signal following a character or block that prepares the receiving device to receive the next character or block.
switching	The controlling or routing of signals in circuits to execute logical or arithmetic operations, or to transmit data between specific points in a network.
Switch phasing	The clock that controls a given switch, PHI1 or PHI2, in respect to the switch capacitor (SC) blocks. The PSoC SC blocks have two groups of switches. One group of these switches is normally closed during PHI1 and open during PHI2. The other group is open during PHI1 and closed during PHI2. These switches can be controlled in the normal operation, or in reverse mode if the PHI1 and PHI2 clocks are reversed.
synchronous	<ol style="list-style-type: none">1. A signal whose data is not acknowledged or acted upon until the next active edge of a clock signal.2. A system whose operation is synchronized by a clock signal.

T

tap	The connection between two blocks of a device created by connecting several blocks/components in a series, such as a shift register or resistive voltage divider.
terminal count	The state at which a counter is counted down to zero.
threshold	The minimum value of a signal that can be detected by the system or sensor under consideration.
transistors	The transistor is a solid-state semiconductor device used for amplification and switching, and has three terminals: a small current or voltage applied to one terminal controls the current through the other two. It is the key component in all modern electronics. In digital circuits, transistors are used as very fast electrical switches, and arrangements of transistors can function as logic gates, RAM-type memory, and other devices. In analog circuits, transistors are essentially used as amplifiers.
tri-state	A function whose output can adopt three states: 0, 1, and Z (high-impedance). The function does not drive any value in the Z state and, in many respects, may be considered to be disconnected from the rest of the circuit, allowing another output to drive the same net .

U

UART	A UART or universal asynchronous receiver-transmitter translates between parallel bits of data and serial bits.
user	The person using the PSoC device and reading this manual.
user modules	Pre-build, pre-tested hardware/firmware peripheral functions that take care of managing and configuring the lower level Analog and Digital PSoC Blocks. User Modules also provide high level API (Application Programming Interface) for the peripheral function.
user space	The bank 0 space of the register map. The registers in this bank are more likely to be modified during normal program execution and not just during initialization. Registers in bank 1 are most likely to be modified only during the initialization phase of the program.

V

Vdd	A name for a power net meaning "voltage drain." The most positive power supply signal. Usually 5 or 3.3 volts.
volatile	Not guaranteed to stay the same value or level when not in scope.
Vss	A name for a power net meaning "voltage source." The most negative power supply signal.

W

watchdog timer	A timer that must be serviced periodically. If it is not serviced, the CPU will reset after a specified period of time.
waveform	The representation of a signal as a plot of amplitude versus time.

X

XOR

See ***Boolean Algebra***.

#

- 8-pin global interconnect 314
- 16-pin global interconnect 315
- 20- to 24-pin global interconnect 316
- 28- to 32-pin global interconnect 317
- 3.768 kHz clock selection 119
- 32 kHz clock selection 117, 129
- 32k Select bit 126, 291
- 32-pin global interconnect for the CY8C21x34,
CY7C603xx, CYWUSB6953 318
- 44-pin global interconnect 319
- 48-pin global interconnect 320
- 56-pin global interconnect for the CY8C24x94,
CY7C64215 321
- 100-pin global interconnect 322

A

- ABF_CR0 register 112, 267, 409
 - for two column limited analog system 449
- ABUFxEN bits 112, 267
- ACap bits
 - in ASCxxCR0 register 195
 - in ASDxxCR0 register 200
- ACBxxCR0 register 188, 419
- ACBxxCR1 register 190, 419
- ACBxxCR2 register 193, 420
- ACBxxCR3 register 187, 417
- ACExxCR1 register 192, 450
- ACExxCR2 register 194, 450
- ACIx bits 175
- ACK bit 225
- ACK'd Transaction bit 172, 282
- ACMux bits 197
- ACol0Mux bit 177
- AColxMux bits 112, 267
- acronyms 27
- ADCEN bit 185
- ADCx_CR register 185, 445
- ADCx_TR register 296, 449
- Address bits
 - in I2C_SCR register 225
 - in PMAx_RA register 264
 - in PMAx_WA register 263
- address spaces, CPU core 63
- addressing modes, M8C 67
- ADI, *See* array digital interconnect
- AGNDBYP bit 300, 500
- AIN bits 180
- ALT_CR0 register 275, 393
 - for two column limited analog system 448
- ALT_CR1 register 277, 393
- AMD_CR0 register 269, 391
 - for two column limited analog system 447
- AMD_CR1 register 273, 392
 - for two column limited analog system 448
- amplifiers, instruction 417
- AMux bits 201
- AMux connections 399
- AMUXCFG register 177, 521, 522
- AMX_IN register 175, 408
 - for two column limited analog system 449
- Analog 0 bit
 - in INT_CLR0 register 230
 - in INT_MSK0 register 239
- Analog 1 bit
 - in INT_CLR0 register 230
 - in INT_MSK0 register 239
- Analog 2 bit
 - in INT_CLR0 register 230
 - in INT_MSK0 register 239
- Analog 3 bit
 - in INT_CLR0 register 230
 - in INT_MSK0 register 239
- analog array 395
 - AMux connections 399
 - analog comparator bus 401
 - architecture 395
 - BMux SC/SD connections 401
 - CMux connections 400
 - in two column limited analog system 435
 - NMux connections 396
 - PMux connections 397
 - RBotMux connections 398
 - temperature sensing 402
- analog array power control bits 412
- analog blocks, defining 372
- analog column clock generation 379
 - in two column limited analog system 432
- analog comparator bus interface 378, 401
 - in two column limited analog system 432

analog data bus interface 378
 analog ground bypass 412
 analog input configuration 403
 1 column configuration 407
 2 column configuration 405
 4 column configuration 404
 architecture 403
 in two column limited analog system 437
 register definitions 408
 analog input, GPIO 104
 analog interface 377
 architecture 377
 column clock generation 379
 comparator bus interface 378
 data bus interface 378
 decimator interface 379
 in two column limited analog system 431
 incremental ADC interface 379
 LUT function 378
 modulator interface 380
 register definitions 386
 SAR hardware acceleration 382
 synchronization interface 381
 analog modulator interface 380
 in two column limited analog system 434
 analog mux bus 518
 analog output drivers 111
 architecture 111
 configurations 111
 register definitions 112
 analog reference 411
 analog ground bypass 412
 architecture 411
 in two column limited analog system 441
 register definitions 412
 analog single slope ADC in two column limited analog system 433
 analog synchronization interface 381
 analog system
 architecture 371
 characteristics 371
 defining analog blocks 372
 functionality 372
 overview 20, 371
 register naming conventions 373
 register summary 373
 See *also* two column limited analog system 431
 AnalogBus bit
 in ACBxxCR1 register 190
 in ASCxxCR2 register 198
 in ASDxxCR2 register 202
 architecture 415
 analog system 371
 digital system 307
 PSoC core 59
 system resources 453
 top level 20
 ARefMux bits

 in ASCxxCR3 register 199
 in ASDxxCR3 register 203
 ARF_CR register 179, 412
 array digital interconnect 325
 architecture 325
 configuration 326
 ASCxxCR0 register 195, 425
 ASCxxCR1 register 197, 426
 ASCxxCR2 register 198, 426
 ASCxxCR3 register 199, 427
 ASDxxCR0 register 200, 428
 ASDxxCR1 register 201, 429
 ASDxxCR2 register 202, 429
 ASDxxCR3 register 203, 430
 ASExxCR0 register 196, 451
 ASign bit
 in ASCxxCR0 register 195
 in ASDxxCR0 register 200
 ASY_CR register 182, 387
 asynchronous receiver function 343
 asynchronous transmitter function 343
 AUTO bit 185
 AutoZero bit
 in ASCxxCR2 register 198
 in ASDxxCR2 register 202

B

bank 0 registers 149
 register mapping table 142
 bank 1 registers 253
 register mapping table 143
 basic paging in RAM paging 86
 BCap bits 197, 201
 BCol1Mux bit 177
 BCSEL bits 214
 BDG_TR register 300, 500
 Bit Bang Clock bit 158
 Bit Bang Mode bit 158
 BMux SC/SD connections 401
 BMuxSC bits 199
 BMuxSD bit 203
 BSW bit 203
 Bus Busy bit 228
 Bus Error bit 225
 Bus Error IE bit 224
 Bus Reset bit for USB 234, 238
 BusActivity bit 281
 Bypass bit 112, 267
 Byte Complete bit 226
 Byte Count bits 173

C

Calibrate0 function in SROM 77
 Calibrate1 function in SROM 78
 capacitive sensing in IO analog multiplexer 518
 Capture Int bit 156

- Carry bit 94, 249
 - CBSRC bit 185
 - CCap bits
 - in ASCxxCR2 register 198
 - in ASDxxCR2 register 202
 - chaining signals in digital blocks 337
 - characteristics of the PSoC device 22
 - in system resources 454
 - in the analog system 371
 - in the digital system 307
 - Checksum function in SROM 77
 - chip-wide analog input in IO analog multiplexer 519
 - CLatch bit 193
 - CLDIS bits 183
 - CLK_CR0 register 265, 390
 - for two column limited analog system 446
 - CLK_CR1 register 266, 390
 - for two column limited analog system 447
 - CLK_CR2 register 278, 394
 - CLK_CR3 register for two column limited analog system 279, 280, 448
 - CLK1X bits 184
 - Clock Phase bit in DCBxxCR0 160, 161
 - Clock Polarity bit 160, 161
 - Clock Rate bits 224
 - clock, external digital clock 461
 - clock doubler 461
 - switch operation 461
 - clocking
 - in SROM 83
 - rates for I2C 487
 - ClockPhase bit
 - in ASCxxCR0 register 195
 - in ASDxxCR0 register 200
 - clocks digital, *See* digital clocks
 - CMOUT bit 187
 - CMP_CR0 register 180, 386
 - for two column limited analog system 444
 - CMP_CR1 register 177, 183, 388
 - for two column limited analog system 445
 - CMP_GO_EN register 271, 391, 447
 - CMP_GO_EN1 register 272, 392
 - CMPST bit 185
 - CMux connections 400
 - COMP bits 180
 - CompBus bit
 - in ACBxxCR1 register 190
 - in ACExxCR1 register 192
 - in ASCxxCR2 register 198
 - in ASDxxCR2 register 202
 - CompCap bit 193
 - configuration
 - analog input 403
 - analog output drivers 111
 - array digital interconnect 326
 - decimator 475
 - multiply accumulate 469
 - configuration registers in digital blocks
 - DxBxxFN register 352
 - DxBxxIN register 353
 - DxBxxOU register 353
 - continuous time block 415
 - in two column limited analog system 441
 - register definitions 417
 - conventions, documentation
 - acronyms 27
 - numeric naming 26
 - register conventions 26, 141, 148
 - register names 148
 - units of measure 26
 - core, *See* PSoC core
 - Count MSb bit 170
 - counter for digital blocks
 - functionality 338
 - register definitions 347
 - timing 356
 - CPhase bit 193
 - CPU core 63
 - address spaces 63
 - addressing modes 67
 - instruction formats 66
 - instruction set summary 64–65
 - internal M8C registers 63
 - register definitions 72
 - CPU Sleep bit 126, 291
 - CPU speed settings 122, 134
 - CPU_F register 72, 93, 102, 249
 - CPU_SCR0 register 133, 252, 504
 - CPU_SCR1 register 81, 115, 121, 132, 251
 - CRCPRS for digital blocks
 - functionality 339
 - register definitions 348
 - timing 359
 - crosspoint switch in IO analog multiplexer 519
 - CT, *See* continuous time block
 - CUR_PP register 89, 219
 - current page pointer in RAM paging 87
- ## D
-
- DAC_CR register 305, 522
 - DAC_D register 250, 521
 - DACDATA bits 250
 - data and control registers in digital blocks
 - DxBxxCR0 registers 350
 - DxBxxDRx registers 346
 - Data bits
 - in DxBxxDR0 register 153
 - in DxBxxDR1 register 154
 - in DxBxxDR2 register 155
 - in I2C_DR register 227
 - in MACx_CL0/ACCx_DR3 register 210
 - in MACx_CL1/ACCx_DR2 register 211
 - in MACx_X/ACCx_DR1 register 208
 - in MACx_Y/ACCx_DR0 register 209
 - in MULx_DH register 206

- in MULx_DL register 207
 - in MULx_X register 204
 - in MULx_Y register 205
 - in PMAx_DR register 164
 - in PRTxDR register 149
 - in TMP_DRx register 186
- Data Byte bits in USB 174
- Data High Byte bits 243
- Data Low Byte bits 244
- Data Toggle bit
 - in EP0_CNT register 173
 - in EPx_CNT1 register 170
- Data Valid bit
 - in EP0_CNT register 173
 - in EPx_CNT1 register 170
- DBB0x bit
 - in INT_CLR1 register 232
 - in INT_MSK1 register 240
- DBB1x bit
 - in INT_CLR1 register 231, 232
 - in INT_MSK1 register 240
- DBB2x bit
 - in INT_CLR2 register 234
 - in INT_MSK2 register 237, 238
- DBB3x bit
 - in INT_CLR2 register 233, 234
 - in INT_MSK2 register 237
- DCB0x bit
 - in INT_CLR1 register 232
 - in INT_MSK1 register 240
- DCB1x bit
 - in INT_CLR1 register 231
 - in INT_MSK1 register 240
- DCB2x bit
 - in INT_CLR2 register 234
 - in INT_MSK2 register 237
- DCB3x bit
 - in INT_CLR2 register 233
 - in INT_MSK2 register 237
- DCBxxCR0 registers 160–163
- DCLKSx bits
 - in DEC_CR0 register 246
 - in DEC_CR1 register 248
- DCOL bits 246
- dead band for digital blocks
 - functionality 338
 - kill options 339
 - register definitions 347
 - timing 357
- DEC_CR0 register 245, 388, 480
 - for two column limited analog system 446
- DEC_CR1 register 247, 388, 480
 - for two column limited analog system 446
- DEC_CR2 register 297, 481
- DEC_DH register 243, 479
- DEC_DL register 244, 479
- decimator 475
 - architecture 475
 - configurations 475
 - register definitions 479
 - type 1 block 475
 - type 2 block 477
- decimator and incremental ADC interface 379
- destination instructions
 - direct 69
 - direct source direct 70
 - direct source immediate 69
 - indexed 69
 - indexed source immediate 70
 - indirect post increment 71
- detailed register listing 147
- development kits 24
- Device Address bits 167
- device characteristics 22
- device distinctions 23
- digital blocks 335
 - architecture 335
 - asynchronous transmitter and receiver functions 343
 - chaining signals 337
 - configuration registers 352
 - counter function 338
 - CRCPRS function 339
 - data and control registers 345
 - dead band function 338
 - input clock resynchronization 336
 - input multiplexers 336
 - interrupt mask registers 351
 - output de-multiplexers 337
 - register definitions 345
 - SPI master function 342
 - SPI protocol function 341
 - SPI slave function 342
 - timer function 337
 - timing diagrams 355
- digital blocks timing diagrams
 - counter timing 356
 - CRCPRS timing 359
 - dead band timing 357
 - receiver timing 368
 - SPI mode timing 359
 - SPIM timing 360
 - SPIS timing 363
 - timer timing 355
 - transmitter timing 366
- digital clocks 459
 - 32 KHz crystal oscillator 461
 - architecture 459
 - device distinctions 462
 - external clock 461
 - internal low speed oscillator 459
 - internal main oscillator 459
 - register definitions 463
 - system clocking signals 459
- digital IO, GPIO 103
- digital system
 - architecture 307

- characteristics 307
- overview 20
- register naming conventions 308
- register summary 308
- distinctions of the PSoC device 23
- DMI bit 169
- DMO bit 169
- documentation
 - conventions 26
 - interpreting the analog system 371
 - interpreting the digital system 307
 - interpreting the PSoC core 59
 - interpreting the system resources 454
 - overview 19
- DPI bit 169
- DPO bit 169
- Drive Mode 2 bits 152
- Drive Mode bit 169
- DxBxxCR0 registers 156–159, 350
- DxBxxDR0 register 153, 346
- DxBxxDR1 register 154, 346
- DxBxxDR2 register 155, 346
- DxBxxFN register 257, 352
- DxBxxIN register 259, 353
- DxBxxOU register 261, 353

E

- ECNT bit 247
- ECO EX bit 81, 251
- ECO EXW bit 81, 251
- ECO, *See* external crystal oscillator
- ECO_TR register 123, 301
- EN bit 177
- Enable bit
 - in DCBxxCR0 register 160–163
 - in DxBxxCR0 register 156–159
- ENABLE bit in DAC_CR register 305
- ENABLE bits in MUX_CRx registers 287
- Enable Master bit 224
- Enable Slave bit 224
- EnableLock bit 281
- Endpoint 0 bit for USB 234, 237
- Endpoint 1 bit for USB 234, 237
- Endpoint 2 bit for USB 234, 237
- Endpoint 3 bit for USB 233, 237
- Endpoint 4 bit for USB 233, 237
- ENSWINT bit 100, 236
- EP0_CNT register 173, 534
- EP0_CR register 172, 533
- EP0_DRx register 174, 534
- EPx Count bits 171
- EPx_CNT register 171, 532
- EPx_CNT1 register 170, 531
- EPx_CR0 register 282, 536
- EraseAll function in SRAM 77
- EraseBlock function in SRAM 76
- EXGAIN bit 187

- EXTCLKEN bit 127, 293
- external crystal oscillator 119
 - architecture 119
 - external components 120
 - register definitions 121
- external digital clock 461
- external reset 505

F

- FCap bit
 - in ASCxxCR0 register 195
 - in ASDxxCR0 register 200
- Flash
 - memory organization 75
 - program register 304
 - tables 77
- FLS_PR1 register 82, 304
- Frame Number bits 165, 166
- Framing Error bit 163
- FSW0 bit
 - in ASCxxCR3 register 199
 - in ASDxxCR3 register 203
- FSW1 bit
 - in ASCxxCR3 register 199
 - in ASDxxCR3 register 203
- FullRange bit 194
- full-speed USB 523
 - architecture 523
 - interrupts 527
 - memory arbiter 524
 - oscillator lock 526
 - register definitions 529
 - regulator 526
 - reset 527
 - sample schematic 528
 - suspend mode 527
 - transceiver 526
 - USB SIE 523
 - USB SRAM 524
- functionality, analog system 372
- FVal bit 196

G

- Gain bit 188
- GDI, *See* global digital interconnect
- GDI_E_IN register 284, 323
- GDI_E_OU register 286, 324
- GDI_O_IN register 283, 323
- GDI_O_OU register 285, 324
- general purpose IO 103
 - analog input 104
 - architecture 103
 - block interrupts 106
 - digital IO 103
 - drive modes 109
 - global IO 104

- interrupt modes 110
- register definitions 107
- GIE bit 94, 249
- GIES bit 252
- global digital interconnect 313
 - 8-pin global interconnect 314
 - 16-pin global interconnect 315
 - 20- to 24-pin global interconnect 316
 - 28- to 32-pin global interconnect 317
 - 32-pin global interconnect for the CY8C21x34, CY7C603xx, CYWUSB6953 318
 - 44-pin global interconnect 319
 - 48-pin global interconnect 320
 - 56-pin global interconnect for the CY8C24x94, CY7C64215 321
 - 100-pin global interconnect 322
 - architecture 313
 - register definitions 323
- global IO in GPIO 104
- Global Select bits 151
- GOExEN bit 217, 218
- GOO2 bit 272
- GOO3 bit 272
- GOO6 bit 272
- GOO7 bit 272
- GOOxEN bit 217, 218
- GPIO bit
 - in INT_CLR0 register 229
 - in INT_MSK0 register 239
- GPIO block interrupts 106
- GPIO, See general purpose IO

H

- HBE bit 179
- help, getting
 - development kits 24
- HIGH bits 178

I

- I2C bit 99, 100
 - in INT_CLR3 register 235
 - in INT_MSK3 register 236
- I2C system resource 483
 - application description 484
 - architecture 483
 - basic data transfer 483
 - basic IO timing 493
 - clock generation timing 493
 - clock rates 487
 - master clock synchronization 498
 - master lost arbitration timing 497
 - master operation 485
 - master restart timing 496
 - master stop timing 496
 - master timing 495
 - master/slave stall timing 497

- register definitions 486
- slave operation 484
- status timing 494
- I2C_CFG register 224, 486
- I2C_DR register 227, 490
- I2C_MSCR register 228, 491
- I2C_SCR register 225, 488
- ICLKs bits
 - in DEC_CR0 register 245
 - in DEC_CR1 register 247
- IDEC bit 247
- IDX_PP register 91, 221
- IGEN bits 245
- ILO, See internal low speed oscillator
- ILO_TR register 117, 299
- IMO, See internal main oscillator
- IMO_TR register 116, 298
- IMO_TR1 register 302, 537
- IMO_TR2 register 303, 537
- IMODIS bit 127, 293
- IN Received bit 172
- incremental ADC interface 379
- index memory page pointer in RAM paging 87
- input for digital blocks
 - clock resynchronization 336
 - multiplexers 336
- INSAMP bit 187
- instruction amplifiers 417
- instruction formats
 - 1-byte instructions 66
 - 2-byte instructions 66
 - 3-byte instructions 67
- instruction set summary 64–65
- INT_CLR0 register 98, 229, 463
- INT_CLR1 register 98, 231
- INT_CLR2 register 98, 233
- INT_CLR3 register 98, 235
- INT_MSK0 register 100, 131, 239, 463
- INT_MSK1 register 100, 240, 351
- INT_MSK2 register 100, 237, 351
- INT_MSK3 register 100, 236
- INT_VC register 102, 241
- INTCAP bits 177
- internal low speed oscillator 117
 - architecture 117
 - digital clock description 459
 - register definitions 117
- internal M8C registers 63
- internal main oscillator 113
 - architecture 113
 - digital clock description 459
 - register definitions 115
- internal voltage reference 499
 - architecture 499
 - device distinctions 499
 - register definitions 499
- interrupt controller 95
 - application description 97

- architecture 95
- interrupt table 97
- latency and priority 96
- register definitions 98
- Interrupt Enables bits 150
- interrupt mask registers in digital blocks
 - INT_MSK1 register 351
 - INT_MSK2 register 351
- interrupt table for PSoC devices 97
- interrupts in RAM paging 87
- IO analog multiplexer 517
 - application description 518
 - architecture 517
 - capacitive sensing 518
 - chip-wide analog input 519
 - crosspoint switch 519
 - register definitions 521
- IOMode bit 169
- IRAMDIS bit 81, 251
- IRANGE bit 305
- IRESS bit 81, 251
- ISx bits 214

L

- look-up table (LUT) function 378, 432
- LOREN bit 185
- Lost Arb bit 225
- LOW bits 178
- LPCMPEN bit 187
- LRB bit 225
- LSb First bit 160, 161
- LUT0 bits 215
- LUT1 bits 215
- LUT2 bits 216
- LUT3 bits 216

M

- M8C, *See* CPU core
- MAC, *See* multiply accumulate
- MACx_CL0/ACCx_DR3 register 210, 473
- MACx_CL1/ACCx_DR2 register 211, 473
- MACx_X/ACCx_DR1 register 208, 472
- MACx_Y/ACCx_DR0 register 209, 472
- mapping tables, registers 141
- Master Mode bit 228
- master operation, I2C 485
- measurement units 26
- memory arbiter in USB 524
- Mode bits 282
- Mode bits for USB 172
- multiply accumulate 469
 - accumulation after multiplication 470
 - architecture 469
 - configurations 469
 - multiplication with no accumulation 470
 - register definitions 470

- MULx_DH register 206, 471
- MULx_DL register 207, 472
- MULx_X register 204, 471
- MULx_Y register 205, 471
- MUX_CRx register 287, 522
- MUXCLK bits 177
- MuxClkGE bit 305
- MVI instructions in RAM paging 87
- MVR_PP register 80, 91, 222
- MVW_PP register 80, 92, 223

N

- NAK Int Enable bit 282
- naming conventions of registers 148
- NMux bits
 - in ACBxxCR1 register 190
 - in ACExxCR1 register 192
- NMux connections 396
 - in two column limited analog system 436
- No Buzz bit 126, 291
- numeric naming conventions 26

O

- OSC_CR0 register 122, 126, 134, 291, 466
- OSC_CR1 register 292, 467
- OSC_CR2 register 116, 127, 293, 468
- OSC_CR3 register 290, 465
- OSC_CR4 register 289, 464
- OSC_GO_EN register 288, 464
- OSCMODE bits 305
- OUT Received bit 172
- output de-multiplexers for digital blocks 337
- Overrun bit 160, 161, 163
- overviews
 - analog system 371
 - digital system 307
 - register reference tables 141
 - system resources 453
 - this manual 19

P

- Page bits
 - in CUR_PP register 219
 - in IDX_PP register 221
 - in MVR_PP register 222
 - in MVW_PP register 223
 - in STK_PP register 220
- Parity Enable bit 162, 163
- Parity Error bit 163
- Parity Type bit 162, 163
- Pass Mode bit 159
- Pending Interrupt bits 241
- PgMode bits 93, 249
- phase-locked loop 125
 - architecture 125

- register definitions 125
- pin information, See pinouts
- pinouts
 - 8-pin parts 29
 - 16-pin part 30
 - 20-pin parts 31
 - 24-pin part 32
 - 28-pin parts 33
 - 32-pin parts 35
 - 44-pin part 37
 - 48-pin parts 38
 - 56-pin parts 41
 - 68-pin parts 45
 - 100-ball parts 55
 - 100-pin parts 47
- PLL Mode bit 126, 291
- PLL, See phase-locked loop
- PLLGAIN bit 127, 293
- PMAx_BGN register 263, 535
- PMAx_CUR register 264, 535
- PMAx_DR register 164, 529
- PMux bits
 - in ACBxxCR1 register 191
 - in ACExxCR1 register 192
- PMux connections 397
 - in two column limited analog system 437
- POR and LVD 513
 - architecture 513
 - register definitions 513
- PORS bit 252
- power consumption, system resets 507
- power on reset 505
- product upgrades 24
- ProtectBlock function in SROM 76
- PRTxDM0 register 109, 253
- PRTxDM1 register 109, 254
- PRTxDM2 register 109, 152
- PRTxDR register 107, 149
- PRTxGS register 108, 151
- PRTxIC0 register 109, 255
- PRTxIC1 register 109, 256
- PRTxIE register 108, 150
- PS2PUEN bit 169
- PSelect bit 224
- PSoC core
 - architecture 59
 - overview 20
 - register summary 60
- PSoC device
 - characteristics 22
 - distinctions 23
- PWM ADC interface in two column limited analog system 434
- PWM_CR register 178, 444
- PWMEN bit 178
- PWR bits
 - in ABF_CR0 register 112, 267
 - in ACBxxCR2 register 193

- in ACExxCR2 register 194
- in ARF_CR register 179
- in ASCxxCR3 register 199
- in ASDxxCR3 register 203

R

- RAM paging 85, 539
 - architecture 85, 539
 - basic paging 86
 - current page pointer 87
 - index memory page pointer 87
 - interrupts 87
 - MVI instructions 87
 - register definitions 89
 - stack operations 86
- RBotMux bits 189
- RBotMux connections 398
- RD bit 168
- RDI, See row digital interconnect
- RDixS register 214, 331
- RDixLT0 register 215, 332
- RDixLT1 register 216, 332
- RDixRI register 212, 329
- RDixRO0 register 217, 333
- RDixRO1 register 218, 333
- RDixSYN register 213, 330
- ReadBlock function in SROM 75
- receiver for digital blocks
 - functionality 343
 - register definitions 349
 - timing 368
- REF bits 179
- RegEnable bit 281
- register conventions 26, 148
- register definitions
 - analog input configuration 408
 - analog interface 386
 - analog output drivers 112
 - analog reference 412
 - continuous time block 417
 - CPU core 72
 - decimator 479
 - digital blocks 345
 - digital clocks 463
 - external crystal oscillator 121
 - general purpose IO 107
 - global digital interconnect 323
 - I2C 486
 - internal low speed oscillator 117
 - internal main oscillator 115
 - internal voltage reference 499
 - interrupt controller 98
 - IO analog multiplexer 521
 - multiply accumulate 470
 - phase-locked loop 125
 - POR and LVD 513
 - RAM paging 89

- row digital interconnect 329
 - sleep and watchdog 131
 - supervisory ROM 78
 - switch mode pump 511
 - switched capacitor block 424
 - system resets 503
 - two column limited analog system 443
 - USB, full-speed 529
 - register mapping tables
 - bank 0 registers 142
 - bank 1 registers 143
 - for USB registers 144–145
 - register reference 141
 - mapping tables 142–145
 - registers
 - analog register summary 373
 - bank 0 registers 149
 - bank 1 registers 253
 - core register summary 60
 - detail of all registers 147
 - digital register summary 308
 - internal M8C registers 63
 - maneuvering around 147
 - mapping tables 141
 - system resources register summary 455
 - two column limited analog system register summary 443
 - RES_WDT register 131, 242
 - Restart Gen bit 228
 - R1x bits 212
 - R1xSYN bits 213
 - row digital interconnect 327
 - architecture 327
 - register definitions 329
 - timing diagram 334
 - RTapMux bits 188
 - RTopMux bit 188
 - RX Active bit 163
 - RX Reg Full bit 160, 161, 163
- S**
- sample schematic for USB 528
 - SAR hardware acceleration 382
 - SARCNT bits 182
 - SARCOL bits 182
 - SARSIGN bit 182
 - SC type C control registers 425
 - SC type D control registers 428
 - SC, *See also* switched capacitor block
 - SEL2 bits 272
 - SEL3 bits 272
 - Setup Received bit 172
 - SHEN bit 185
 - Sinc2 function 476
 - slave operation, I2C 484
 - sleep and watchdog 129
 - 32 kHz clock selection 129
 - application description 130
 - architecture 129
 - CPU speed settings 134
 - register definitions 131
 - sleep internal selections 134
 - sleep timer 129
 - Sleep bit 126, 291
 - in CPU_SCR0 register 252
 - in INT_CLR0 register 229
 - in INT_MSK0 register 239
 - sleep interval selections 122, 134
 - sleep timer 129
 - SLIMO bit 81, 113, 251
 - SMP, *See* switch mode pump
 - source instructions
 - direct 68
 - immediate 67
 - indexed 68
 - indirect post increment 71
 - SPI Complete bit 160, 161
 - SPI for digital blocks
 - master function 342
 - master register 348
 - mode timing 359
 - protocol function 341
 - slave function 342
 - slave register 349
 - SPIM timing for digital blocks 360
 - SPIS timing for digital blocks 363
 - SplitMux bit 305
 - SRAM with USB 524
 - SROM, *See* supervisory ROM
 - stack operations in RAM paging 86
 - Stall bit 282
 - Start Gen bit 228
 - Start of Frame bit for USB 234, 237
 - started, getting 24
 - STK_PP register 79, 90, 220
 - STOP bit 252
 - Stop IE bit 224
 - Stop Status bit 225
 - summary of registers
 - analog system 373
 - digital system 308
 - mapping tables 141
 - PSoC core 60
 - system resources 455
 - two column limited analog system 443
 - supervisory ROM 73
 - architecture 73
 - Calibrate0 function 77
 - Calibrate1 function 78
 - Checksum function 77
 - clocking 83
 - EraseAll function 77
 - EraseBlock function 76
 - function descriptions 74
 - KEY function variables 73

- list of SROM functions 73
- ProtectBlock function 76
- ReadBlock function 75
- register definitions 78
- return code feature 74
- SWBootReset function 74
- TableRead function 77
- WriteBlock function 75
- SWBootReset function in SROM 74
- switch mode pump 509
 - application description 510
 - architecture 509
 - register definitions 511
- switched capacitor block 421
 - application description 423
 - architecture 421
 - in two column limited analog system 442
 - register definitions 424
 - SC type C control registers 425
 - SC type D control registers 428
- SYNCEN bit 182
- SYSCCLKX2DIS bit 127, 293
- system resets 501
 - architecture 501
 - functional details 507
 - power consumption 507
 - power on reset 505
 - register definitions 503
 - timing diagrams 505
 - watchdog timer reset 505
- system resources
 - architecture 453
 - characteristics 454
 - overview 20, 453
 - register summary 455

T

- TableRead function in SROM 77
- TC Pulse Width bit 156
- TD bit 168
- temperature sensing in analog 402, 437
- TEN bit 168
- TestMux bits 193
- timer for digital blocks
 - functionality 337
 - register definitions 346
 - timing 355
- timing diagrams
 - digital blocks 355
 - I2C 493
 - row digital interconnect 334
 - system resets 505
- TMP_DRx register 89, 186
- TMUXEN bit 193
- Transmit bit 225
- transmitter for digital blocks
 - functionality 343

- register definition 349
- timing 366
- TSE0 bit 168
- two column limited analog system 431
 - analog array 435
 - analog comparator bus interface 432
 - analog input configuration 437
 - analog interface 431
 - analog reference 441
 - architecture 431
 - column clock generation 432
 - continuous time block 441
 - device distinctions 442
 - LUT function 432
 - modulator interface 434
 - NMux connections 436
 - PMux connections 437
 - PWM ADC interface 434
 - register definitions 443
 - sample and hold feature 434
 - single slope ADC 433
 - switched capacitor block 442
 - temperature sensing 437
- TX Complete bit 162
- TX Reg Empty bit 160–162
- type 1 decimator block 475
- type 2 decimator block 477

U

- UART function 335
- units of measure 26
- upgrades 24
- USB Enable bit 167
- USB, See full-speed USB
- USB_CR register 167, 530
- USB_CR1 register 281, 536
- USB_SOF0 register 165
- USB_SOF1 register 166
- USB_SOFx register 529
- USBIO_CR0 register 168, 530
- USBIO_CR1 register 169, 531
- USBPUEN bit 169

V

- V Monitor bit
 - in INT_CLR0 register 230
 - in INT_MSK0 register 239
- VC3 bit
 - in INT_CLR0 register 229
 - in INT_MSK0 register 239
- VLT_CMP register 295, 515
- VLT_CR register 294, 511, 514

W

- WakeUp Interrupt bit for USB 233, 237

watchdog timer reset 505
WDRS bit 252
WDSL_Clear bits 242
WriteBlock function in SROM 75

X

XIO bit 93, 249
XRES reset 505

Z

Zero bit 94, 249

