

APPLICATIONS

- Linear Displacement
- Angular Displacement
- Motor Control
- Valve Position
- Proximity Detection
- Current Spike Detection

Linear / Angular / Rotary Displacement Sensors

HMC1501 / HMC1512

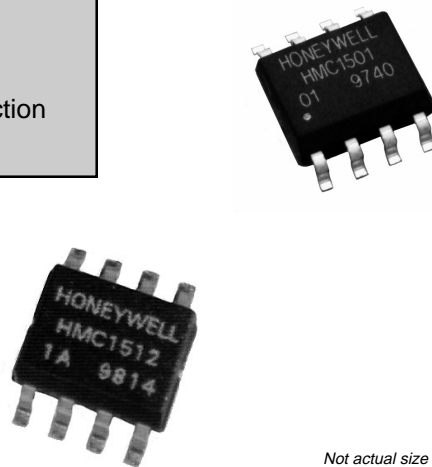

Not actual size

High resolution, low power MR sensor capable of measuring the angle direction of a magnetic field from a magnet with $<0.07^\circ$ resolution.

Advantages of measuring field direction versus field strength include: insensitivity to the tempo of the magnet, less sensitivity to shock and vibration, and the ability to withstand large variations in the gap between the sensor and magnet. These sensors may be operated on 3 volts with bandwidth response of 0-5 MHz. Output is typical Wheatstone bridge.

FEATURES AND BENEFITS

No Rare Earth Magnets	Unlike Hall effect devices which may require samarium cobalt or similar “rare earth” magnets, the HMC1501 and HMC1512 can function with Alnico or ceramic type magnets.
Wide Angular Range	HMC1501—Angular range of $\pm 45^\circ$ with $<0.07^\circ$ resolution. HMC1512—Angular range of $\pm 90^\circ$ with $<0.07^\circ$ resolution.
Effective Linear Range	Linear range of 8mm with two sensors mounted on two ends; range may be increased through multiple sensor arrays operating together.
Absolute Sensing	Unlike incremental “encoding” devices, sensors know the exact position and require no indexing for proper positional output.
Non-Contact Sensing	No moving parts to wear out; no dropped signals from worn tracks as in conventional contact based rotary sensors.
Small Package	Available in an 8-pin surface mount package with case dimensions (exclusive of pins), of 5mm x 4mm x 1.2mm total mounting envelope, with pins of less than 6mm square.
Large Signal Output	Full Scale output range of 120mV with 5V of power supply.

PRINCIPLES OF OPERATION

Anisotropic magnetoresistance (AMR) occurs in ferrous materials. It is a change in resistance when a magnetic field is applied in a thin strip of ferrous material. The magnetoresistance is a function of $\cos^2\theta$ where θ is the angle between magnetization M and current flow in the thin strip. When an applied magnetic field is larger than 80 Oe, the magnetization aligns in the same direction of the applied field; this is called saturation mode. In this mode, θ is the angle between the direction of applied field and the current flow; the MR sensor is only sensitive to the direction of applied field.

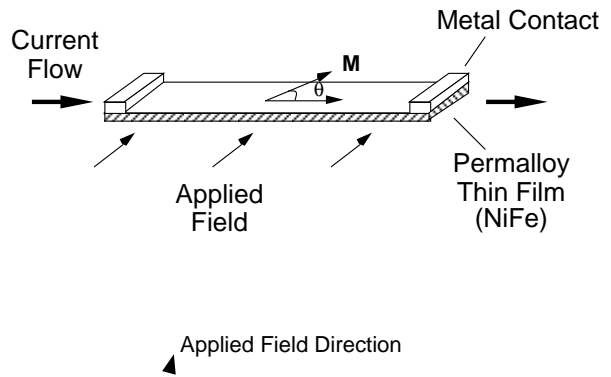

The sensor is in the form of a Wheatstone bridge (Figure 1). The resistance R of all four resistors is the same. The bridge power supply V_s causes current to flow through the resistors, the direction as indicated in the figure for each resistor.

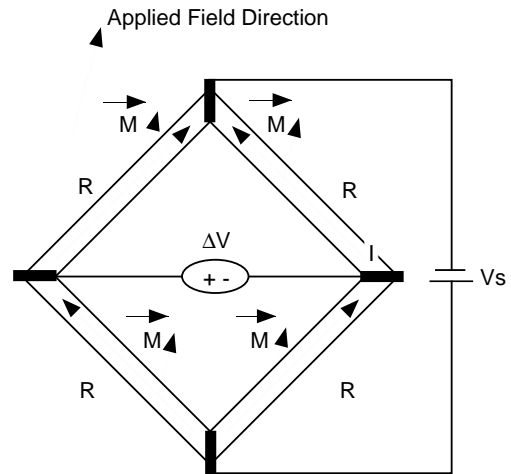
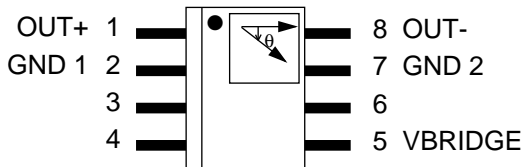

Figure 1

Both HMC1501 and HMC1512 are designed to be used in saturation mode. HMC1501 contains one MR bridge and HMC1512 has two identical MR bridges, coexisting on a single die. Bridge B physically rotates 45° from bridge A. The HMC1501 has sensor output $\Delta V = -V_s S \sin(2\theta)$ and the HMC1512 has sensor output $\Delta V = V_s S \sin(2\theta)$ for sensor A and sensor B output $\Delta V_s = -V_s S \cos(2\theta)$, where V_s is supply voltage, S is a constant, determined by materials. For Honeywell sensors, S is typically 12mV/V.

PINOUT DRAWINGS

HMC1501



HMC1512

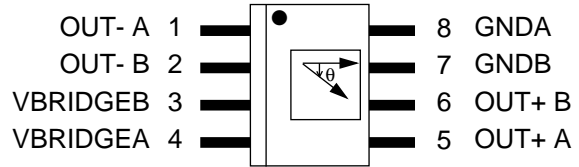

MR SENSOR CIRCUITS

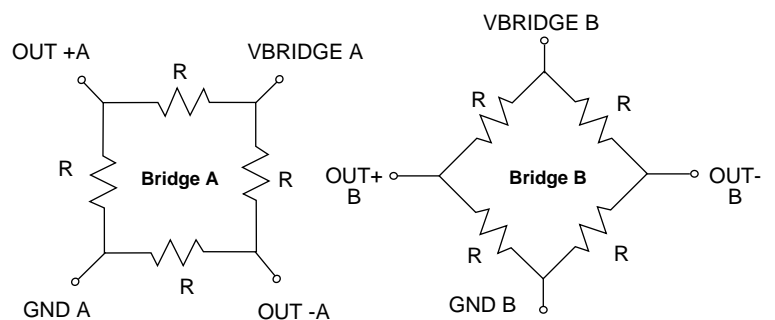
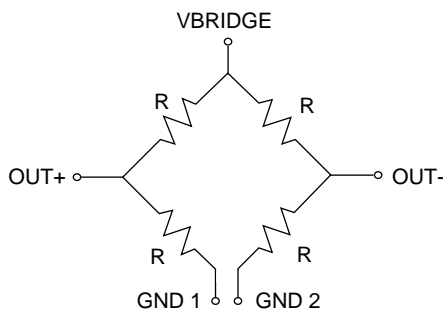

HMC1501

HMC1501 output voltage vs. magnetic field angle

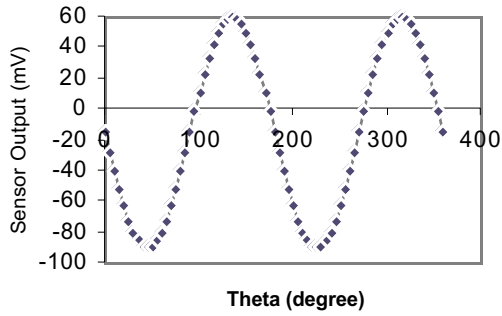

HMC1512

HMC1512 output voltage vs. magnetic field angle

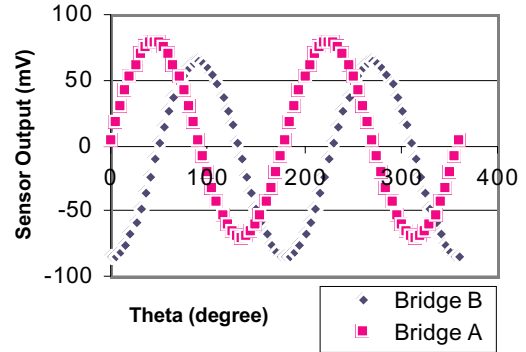

APPLICATION CONFIGURATION

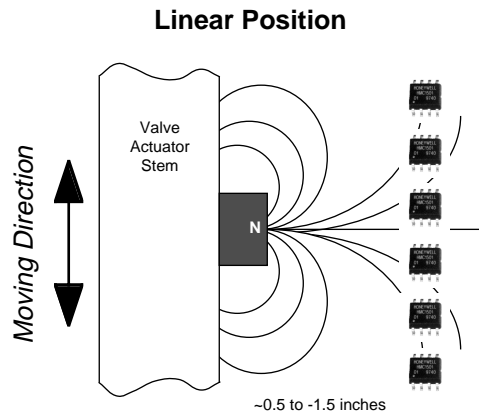
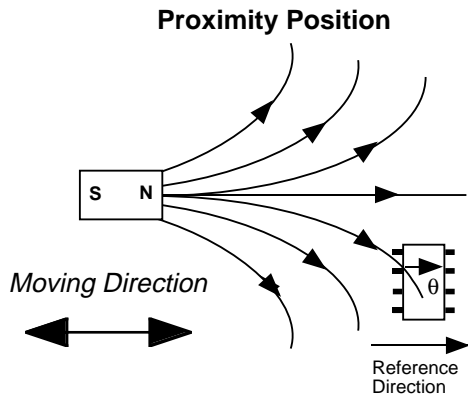

Rotary Position

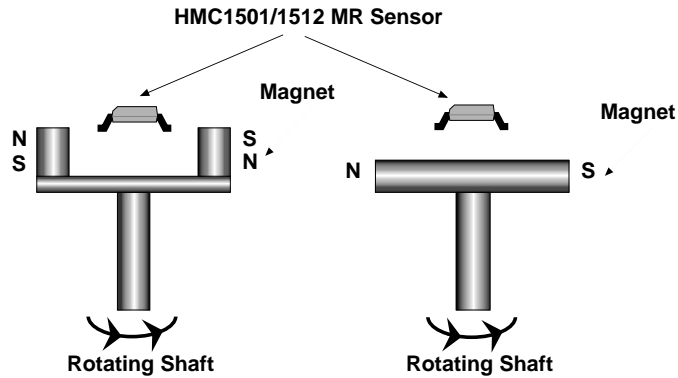

PACKAGE DRAWING 8-Pin SOIC

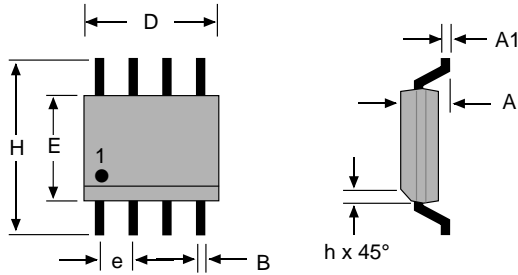

Symbol	Millimeters		Inches	
	Min	Max	Min	Max
A	1.371	1.728	.054	.068
A1	0.101	0.249	.004	.010
B	0.355	0.483	.014	.019
D	4.800	4.979	.189	.196
E	3.810	3.988	.150	.157
e	1.270 ref		.050 ref	
H	5.816	6.198	.229	.244
h	0.381	0.762	.015	.030

SPECIFICATIONS

Characteristics	Conditions	HMC1501			HMC1512			Units
		Min	Typ	Max	Min	Typ	Max	
Bridge supply	V _{bridge} referenced to GND	1	5	25	1	5	25	V
Bridge resistance	Bridge current—1 mA	4	5	6	1.1	2.1	2.5	KΩ
Sensitivity	V _{bridge} = 5V, field 80 Oe, (1) @ zero crossing (2) @ Zero crossing, averaged in the range of 45°		2.1 1.8			2.1 1.8		mV/°
Peak -to-peak Voltage	V _{bridge} = 5V field, 80 Oe	100	120	140	100	120	140	mV
Bridge offset	Field 80 Oe, θ = 0° Bridge A Bridge B	-7	-3	0	-5 -0.5	-3 1	0 2	mV/V
Saturation field	Repeatability <0.03% FS		80			80		G
Bandwidth	Magnetic signal	0		5	0		5	MHz
Hysteresis error	Magnetic field ≥ saturation field, V _{bridge} = 5V		30 1.7x10 ⁻²			30 1.7x10 ⁻²		μV deg
Angle range	≥ Saturation field	-45		+45	-90		+90	deg
Sensitivity tempco*	T _A = -40° C to +125° C V _{bridge} = 5V		-0.32			-0.32		%/° C
Bridge offset tempco**	T _A = -40° C to +125° C		-0.01			-0.01		%/° C, FS
Power Consumption***	V _{bridge} = 5V		5			23		mW

*Sensitivity tempco $C_s = \frac{S_t - S_o}{S_o \cdot t} = -0.32\% \text{ ppm}/^\circ\text{C}$

Where S_o = sensitivity at zero temperature
 t = temperature in the range -40°C to 125°C
 S_t = sensitivity at temperature t

***Power consumption $P = \frac{V^2}{R}$

Where V = Bridge supply voltage
 R = Bridge resistance

**Offset tempco $C_o = \frac{V_o(t) - V_o(o)}{V_{P-P} \cdot t} = -0.01\% \text{ ppm}/^\circ\text{C}$

Where $V_o(o)$ = bridge offset at zero temperature
 V_{P-P} = peak-to-peak voltage
 t = temperature in the range -40°C to 125°C
 $V_o(t)$ = offset at temperature t

1 KA/m = 12.5 Gauss
 1 Tesla = 10⁴ Gauss

Honeywell reserves the right to make changes to any products or technology herein to improve reliability, function or design. Honeywell does not assume any liability arising out of the application or use of any product or circuit described herein; neither does it convey any license under its patent rights nor the rights of others.